



Cynthia Vodopivec
Luminant Generation Company LLC
Luminant
6555 Sierra Dr.
Irving, TX 75039

September 29, 2020

Sent via email

Mr. Andrew R. Wheeler, EPA Administrator
Environmental Protection Agency
1200 Pennsylvania Avenue, N.W.
Mail Code 5304-P
Washington, DC 20460

Re: Martin Lake Steam Electric Station Alternative Closure Demonstration

Dear Administrator Wheeler:

Luminant Generation Company LLC (Luminant) hereby submits this request to the U.S. Environmental Protection Agency (EPA) for approval of a site-specific alternative deadline to initiate closure pursuant to 40 C.F.R. § 257.103(f)(1) for the Ash Pond Area and Permanent Disposal Pond 5 located at the Martin Lake Steam Electric Station near Tatum, Texas. Luminant is requesting an extension pursuant to 40 C.F.R. § 257.103(f)(1) to allow the Ash Pond Area and Permanent Disposal Pond 5 to continue to receive CCR and non-CCR wastestreams after April 11, 2021, such that retrofit activity can be undertaken. Permanent Disposal Pond 5 is an eligible unlined CCR surface impoundment as defined under 40 C.F.R. § 257.53.

Enclosed is a demonstration prepared by Burns & McDonnell that addresses all of the criteria in 40 C.F.R. § 257.103(f)(1)(i)-(iii) and contains the documentation required by 40 C.F.R. § 257.103(f)(1)(iv). As allowed by the agency, in lieu of hard copies of these documents, electronic files were submitted to Kirsten Hillyer, Frank Behan, and Richard Huggins via email. If you have any questions regarding this submittal, please contact Renee Collins at 214-875-8338 or renee.collins@luminant.com.

Sincerely,

A handwritten signature in blue ink that reads "Cynthia E. Vodopivec".

Cynthia Vodopivec
VP - Environmental Health & Safety

Enclosure

cc: Kirsten Hillyer
Frank Behan
Richard Huggins

Martin Lake CCR Surface Impoundments Demonstration for a Site-Specific Alternative to Initiation of Closure Deadline



Luminant Generation Company LLC

**Martin Lake Steam Electric Station
Project No. 122702**

**Revision 0
September 28, 2020**

**Burns & McDonnell
Engineering Firm F-845**

Martin Lake CCR Surface Impoundments Demonstration for a Site- Specific Alternative to Initiation of Closure Deadline

Prepared for

**Luminant Generation Company LLC
Martin Lake Steam Electric Station
Project No. 122702
Tatum, Texas**

**Revision 0
September 28, 2020**

Prepared by

**Burns & McDonnell Engineering Company, Inc.
Kansas City, Missouri**

INDEX AND CERTIFICATION

**Luminant Generation Company LLC
Martin Lake CCR Surface Impoundments
Demonstration for a Site-Specific Alternative to Initiation of Closure Deadline**

Report Index

<u>Chapter Number</u>	<u>Chapter Title</u>	<u>Number of Pages</u>
1.0	Introduction	3
2.0	Workplan	20
4.0	Conclusion	1
Appendix A	Site Plan and Water Balance Diagram	2
Appendix B	Schedule	2

Certification

I hereby certify, as a Professional Engineer in the state of Texas, that the information in this document as noted in the above Report Index was assembled under my direct personal charge. This report is not intended or represented to be suitable for reuse by the Luminant Generation Company LLC or others without specific verification or adaptation by the Engineer.

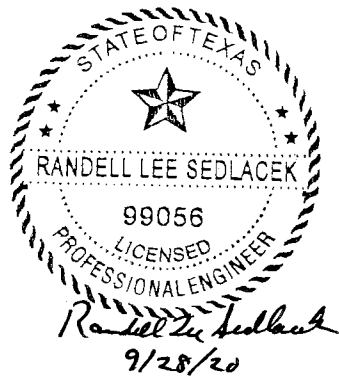

Randell Lee Sedlacek
Randell Lee Sedlacek, P.E. (Texas License No. 99506)

Date: September 28, 2020

TABLE OF CONTENTS

	<u>Page No.</u>
1.0 INTRODUCTION	1-1
2.0 WORKPLAN	2-1
2.1 No Alternative Disposal Capacity and Approach to Obtain Alternative Capacity - § 257.103(f)(1)(iv)(A)(1)	2-1
2.1.1 CCR Wastestreams	2-3
2.1.2 Non-CCR Wastestreams	2-4
2.1.3 Site-Specific Conditions Supporting Alternative Capacity Approach – § 257.103(f)(1)(iv)(A)(1)(i)	2-6
2.1.4 Impact to Plant Operations if Alternative Capacity Not Obtained – § 257.103(f)(1)(iv)(A)(1)(ii)	2-8
2.1.5 Options Considered Both On and Off-Site to Obtain Alternative Capacity	2-9
2.1.6 Approach to Obtain Alternative Capacity.....	2-11
2.1.7 Technical Infeasibility of Obtaining Alternative Capacity prior to April 11, 2021	2-13
2.1.8 Justification for Time Needed to Complete Development of Alternative Capacity Approach – § 257.103(f)(1)(iv)(A)(1)(iii).....	2-14
2.2 Detailed Schedule to Obtain Alternative Disposal Capacity - § 257.103(f)(1)(iv)(A)(2).....	2-15
2.3 Narrative of Schedule and Visual Timeline - § 257.103(f)(1)(iv)(A)(3).....	2-15
2.4 Progress Towards Obtaining Alternative Capacity - § 257.103(f)(1)(iv)(A)(4).....	2-20
3.0 DOCUMENTATION AND CERTIFICATION OF COMPLIANCE	3-1
3.1 Owner’s Certification of Compliance - § 257.103(f)(1)(iv)(B)(1)	3-1
3.2 Visual Representation of Hydrogeologic Information - § 257.103(f)(1)(iv)(B)(2)	3-1
3.3 Groundwater Monitoring Results - § 257.103(f)(1)(iv)(B)(3).....	3-1
3.4 Description of Site Hydrogeology - § 257.103(f)(1)(iv)(B)(4)	3-2
3.5 Corrective Measures Assessment - § 257.103(f)(1)(iv)(B)(5).....	3-2
3.6 Remedy Selection Progress Reports - § 257.103(f)(1)(iv)(B)(6)	3-2
3.7 Structural Stability Assessment - § 257.103(f)(1)(iv)(B)(7).....	3-2
3.8 Safety Factor Assessment - § 257.103(f)(1)(iv)(B)(8)	3-2
4.0 CONCLUSION	4-1
APPENDIX A – SITE PLAN AND WATER BALANCE DIAGRAM	
APPENDIX B – SCHEDULE	
APPENDIX C – EAST ASH POND RETROFIT DESIGN DRAWINGS	
APPENDIX D – WEST ASH POND RETROFIT DESIGN DRAWINGS	

APPENDIX E – NEW SCRUBBER POND RETROFIT DESIGN DRAWINGS
APPENDIX F – COMPLIANCE DOCUMENTS

LIST OF TABLES

	<u>Page No.</u>
Table 2-1: Martin Lake CCR Surface Impoundment Summary	2-2
Table 2-2: Martin Lake CCR Wastestreams	2-4
Table 2-3: Martin Lake Non-CCR Wastestreams	2-5
Table 2-4: Summary of Pond Design Storage Capacity	2-7
Table 2-5: Martin Lake Alternatives for Disposal Capacity	2-10
Table 2-6: Retrofit Project Progress Milestones	2-14

LIST OF ABBREVIATIONS

<u>Abbreviation</u>	<u>Term/Phrase/Name</u>
CCR	Coal Combustion Residual
CFR	Code of Federal Regulations
CY	Cubic Yards
EAP	East Ash Pond
ELG	Effluent Limitations Guidelines and Standards for the Steam Electric Power Generating Point Source Category
EPA	Environmental Protection Agency
FGD	Flue Gas Desulfurization
gal	Gallons
GCL	Geosynthetic Clay Liner
GWPS	Groundwater Protection Standards
HDPE	High Density Polyethylene
Luminant	Luminant Generation Company, LLC
Martin Lake	Martin Lake Steam Electric Station
NSP	New Scrubber Pond
PDP5	Permanent Disposal Pond 5
RCRA	Resource Conservation and Recovery Act
SAP	Sampling and Analysis Plan
SSI(s)	Statistically Significant Increases
SSL(s)	Statistically Significant Levels
WAP	West Ash Pond

1.0 INTRODUCTION

On April 17, 2015, the Environmental Protection Agency (EPA) issued the federal Coal Combustion Residual (CCR) Rule, 40 C.F.R. Part 257, Subpart D, to regulate the disposal of CCR materials generated at coal-fueled electric generating units. The rule is being administered under Subtitle D of the Resource Conservation and Recovery Act (RCRA, 42 U.S.C. § 6901 *et seq.*).

On August 28, 2020, the EPA Administrator issued revisions to the CCR Rule that require all unlined surface impoundments to cease receipt of CCR and non-CCR waste and initiate closure by April 11, 2021, unless an alternative deadline is requested and approved. 40 C.F.R. § 257.101(a)(1) (85 Fed. Reg. 53,516 (Aug. 28, 2020)). Specifically, owners and operators of a CCR surface impoundment may seek and obtain an alternative closure deadline by demonstrating that there is currently no alternative capacity available on or off-site and that it is not technically feasible to complete the development of alternative capacity prior to April 11, 2021. 40 C.F.R. § 257.103(f)(1). To make this demonstration, the facility is required to provide detailed information regarding the process the facility is undertaking to develop the alternative capacity. 40 C.F.R. § 257.103(f)(1). Any extensions granted cannot extend past October 15, 2023, except an extension can be granted until October 15, 2024, if the impoundment qualifies as an “eligible unlined CCR surface impoundment” as defined by the rule. 40 C.F.R. § 257.103(f)(1)(vi). Regardless of the maximum time allowed under the rule, EPA explains in the preamble to the Part A rule that each impoundment “must still cease receipt of waste as soon as feasible, and may only have the amount of time [the owner/operator] can demonstrate is genuinely necessary.” 85 Fed. Reg. at 53,546.

This document serves as Luminant’s Demonstration for a site-specific alternative deadline to initiate retrofit or closure pursuant to 40 C.F.R. § 257.103(f)(1) for the CCR surface impoundments at the Martin Lake Steam Electric Station (Martin Lake), located near Tatum, Texas, which include the following:

- Ash Pond Area:
 - East Bottom Ash Pond (EAP)
 - West Bottom Ash Pond (WAP)
 - New Scrubber Pond (NSP)
- Permanent Disposal Pond 5 (PDP5) – this impoundment qualifies as an “eligible unlined CCR surface impoundment” as defined under § 40 C.F.R. 257.53

To obtain an alternative closure deadline under 40 C.F.R. § 257.103(f)(1), a facility must meet the following three criteria:

1. **§ 257.103(f)(1)(i)** - There is no alternative disposal capacity available on-site or off-site. An increase in costs or the inconvenience of existing capacity is not sufficient to support qualification;
2. **§ 257.103(f)(1)(ii)** - Each CCR and/or non-CCR wastestream must continue to be managed in that CCR surface impoundment because it was technically infeasible to complete the measures necessary to obtain alternative disposal capacity either on or off-site of the facility by April 11, 2021; and
3. **§ 257.103(f)(1)(iii)** - The facility is in compliance with all the requirements of the CCR rule.

To demonstrate that the first two criteria above have been met, 40 C.F.R. § 257.103(f)(1)(iv)(A) requires the owner or operator to submit a work plan that contains the following elements:

- A written narrative discussing the options considered both on and off-site to obtain alternative capacity for each CCR and/or non-CCR wastestream, the technical infeasibility of obtaining alternative capacity prior to April 11, 2021, and the option selected and justification for the alternative capacity selected. The narrative must also include all of the following:
 - An in-depth analysis of the site and any site-specific conditions that led to the decision to select the alternative capacity being developed;
 - An analysis of the adverse impact to plant operations if the CCR surface impoundment in question were to no longer be available for use; and
 - A detailed explanation and justification for the amount of time being requested and how it is the fastest technically feasible time to complete the development of the alternative capacity.
- A detailed schedule of the fastest technically feasible time to complete the measures necessary for alternate capacity to be available, including a visual timeline representation. The visual timeline must clearly show all of the following:
 - How each phase and the steps within that phase interact with or are dependent on each other and the other phases;
 - All of the steps and phases that can be completed concurrently;
 - The total time needed to obtain the alternative capacity and how long each phase and step within each phase will take; and
 - At a minimum, the following phases: engineering and design, contractor selection, equipment fabrication and delivery, construction, and start up and implementation.
- A narrative discussion of the schedule and visual timeline representation, which must discuss the following:

- Why the length of time for each phase and step is needed and a discussion of the tasks that occur during the specific step;
- Why each phase and step shown on the chart must happen in the order it is occurring;
- The tasks that occur during each of the steps within the phase; and
- Anticipated worker schedules.
- A narrative discussion of the progress the owner or operator has made to obtain alternative capacity for the CCR and/or non-CCR wastestreams. The narrative must discuss all the steps taken, starting from when the owner or operator initiated the design phase up to the steps occurring when the demonstration is being compiled. It must discuss where the facility currently is on the timeline and the efforts that are currently being undertaken to develop alternative capacity.

To demonstrate that the third criterion above has been met, 40 C.F.R. § 257.103(f)(1)(iv)(B) requires the owner or operator to submit the following information:

- A certification signed by the owner or operator that the facility is in compliance with all of the requirements of 40 C.F.R. Part 257, Subpart D;
- Visual representation of hydrogeologic information at and around the CCR unit(s) that supports the design, construction and installation of the groundwater monitoring system. This includes all of the following:
 - Map(s) of groundwater monitoring well locations in relation to the CCR unit(s);
 - Well construction diagrams and drilling logs for all groundwater monitoring wells; and
 - Maps that characterize the direction of groundwater flow accounting for seasonal variations.
- Constituent concentrations, summarized in table form, at each groundwater monitoring well monitored during each sampling event;
- A description of site hydrogeology including stratigraphic cross-sections;
- Any corrective measures assessment conducted as required at § 257.96;
- Any progress reports on corrective action remedy selection and design and the report of final remedy selection required at § 257.97(a);
- The most recent structural stability assessment required at § 257.73(d); and
- The most recent safety factor assessment required at § 257.73(e).

2.0 WORKPLAN

To demonstrate that the criteria in 40 C.F.R. § 257.103(f)(1)(i) and (ii) have been met, the following is a workplan consisting of the elements required by § 257.103(f)(1)(iv)(A). This workplan documents that there is no alternative capacity available on or off-site for each of the CCR and/or non-CCR wastestreams that Luminant plans to continue to manage in the Martin Lake CCR surface impoundments and discusses the options considered for alternative disposal capacity. As discussed in more detail below, **Luminant has elected to retrofit its existing CCR surface impoundments.** The workplan provides a detailed schedule for the retrofit project, including a narrative description of the schedule and an update on the progress already made toward retrofit of the CCR surface impoundments. In addition, the narrative includes an analysis of the site-specific conditions that led to the decision to retrofit the impoundments and an analysis of the adverse impact to plant operations if Martin Lake were no longer able to use the CCR surface impoundments.

2.1 No Alternative Disposal Capacity and Approach to Obtain Alternative Capacity - § 257.103(f)(1)(iv)(A)(1)

Luminant owns and operates Martin Lake, a three-unit 2,250-nominal megawatt coal-fired facility located near Tatum, Texas, that burns a mixture of lignite and Powder River Basin coal. Martin Lake has four CCR surface impoundments (listed in Table 2-1) that receive both CCR and non-CCR wastestreams. An aerial view of the Martin Lake site and the CCR surface impoundments can be found on Figure 1 in Appendix A. The first three impoundments listed (EAP, WAP, and NSP) in Table 2-1 are part of the Ash Pond Area referenced on Luminant's CCR website. This area is equipped with a multi-unit groundwater monitoring network. The fourth, PDP5, is located separately from the Ash Pond Area (as shown in Figure 1 in Appendix A) and has its own groundwater monitoring network. As described in more detail below, Martin Lake does not have alternate onsite or offsite storage capacity that would allow the site to continue to operate safely with more than one CCR impoundment out of service at one time (concurrent with summer peak operation) and maintain compliance with environmental permits and obligations.

Table 2-1: Martin Lake CCR Surface Impoundment Summary

CCR Surface Impoundment Name	Year Placed in Service	Impoundment Size (acres) / Storage Volume (acre-feet) ¹	Lined?	Complies with Location Restrictions?	Groundwater Status
East Bottom Ash Pond (EAP)	1977	9.6 / 125.8	No	Yes	Assessment Monitoring was initiated in June 2018. SSLs were identified for beryllium, cobalt, and lithium in January 2019. The Assessment of corrective measures was completed in September 2019. Impoundment retrofit is underway for source control, while selection of the groundwater remedy is currently in the feasibility study phase.
West Bottom Ash Pond (WAP)	1977	14.6 / 232.6	No	Yes	
New Scrubber Pond (NSP)	1989	12.5 / 198.9	No	Yes	
Permanent Disposal Pond 5 (PDP5)	2010	40 / 190.3	Yes ²	Yes	SSIs have been identified with successful Alternate Source Demonstrations completed in 2018 and 2019. Remains in Detection Monitoring.

¹Values listed in Inflow Design Flood Control System Plan prepared by Pastor, Behling & Wheeler, LLC in October 2016.

²PDP5 was originally classified as lined per 40 C.F.R. § 257.71(a)(1)(i), which was subsequently vacated by the U.S. Court of Appeals for the D.C. Circuit. This impoundment now qualifies as an eligible unlined CCR surface impoundment per § 257.53.

The Martin Lake facility is unique because it operates its CCR-related outfalls as essentially zero discharge facilities. Martin Lake typically only discharges non-contact cooling water via Outfall 001 and flow from the sewage treatment plant via Outfall 101. Martin Lake utilizes the CCR surface impoundments, the low volume wastewater retention pond, and the stormwater retention pond to assist in the management of all the remaining water process flows and stormwater on the plant site. These ponds are inter-connected with pumps and piping systems to allow transport of the non-CCR wastestreams to the CCR surface impoundments as make-up water. There are permitted outfalls for discharge from the wastewater recycling plant (Outfall 201), stormwater retention pond (Outfall 301), low volume wastewater pond (Outfall 401), and from the solid waste disposal area (Outfall 501); however, these outfalls typically do not discharge and the wastewaters are used to support water reuse at the site. The existing site water balance is included in Appendix A of this demonstration (see Figure 2).

The water recycling practices discussed above are both necessary and extremely beneficial from an environmental perspective. Recycling is needed because of several factors related to the water quality limitations found and/or referenced in the facility's TPDES wastewater permit. The most restrictive permit requirement is a mass limit of 17.5 pounds for the discharge of selenium (per calendar year) into Martin Creek Reservoir, which means that the volume of discharge is inverse to the concentration of selenium in the wastewater. Martin Lake has the capability to treat its wastewater to a value well below the permitted concentration limit(s), but the treatment processes are physically limited to a rate that is slower than the rate of use of the wastewater as make-up to the CCR systems. Reuse in the CCR systems versus treatment/discharge also avoids the creation, management, and disposal of several high concentration wastestreams that are produced by the wastewater treatment processes used for the removal of selenium.

The bottom-ash transport and flue-gas desulfurization (FGD) systems at Martin Lake are both large consumers of water, requiring constant make-up. The reuse of wastewater as make-up is made possible because of a generally favorable climate (long, hot summers with high evaporation rate), the use of low chloride fuel sources (lignite & western coal), and intensive wastewater management focused on recycling and reuse of wastewater. The plant uses its non-CCR wastewater (e.g., low volume wastewater, boiler water treatment wastewater, lignite and coal pile runoff, stormwater, etc.) as sources of make-up water that are continuously recycled into the systems.

This method of operation has also become necessary because of the limited availability of surface water in the State of Texas. Texas is a water rights state, and surface water withdrawals and use are highly regulated. Over the past several decades the addition of new pollution control devices and regulations have increased the water consumption of the facility. The use of non-CCR wastewater as make-up to the CCR systems has prevented the need for a large increase in the volume of freshwater needed. If Martin Lake were unable to continue to use the impoundments as holding ponds for non-CCR wastestreams, the increased demand for freshwater makeup is estimated at 2.3 to 3.2 billion gallons per year (7,000 to 10,000 acre-feet of water), with a similar volume of wastewater discharged. That volume of freshwater, to replace the reuse of wastewater, is not available in the Martin Lake watershed as a water right for industrial use.

2.1.1 CCR Wastestreams

Luminant evaluated each CCR wastestream generated at Martin Lake (See Table 2-2). The existing site water balance is included in Appendix A of this demonstration (see Figure 2). Fly ash is collected dry and disposed in A-1 Area Landfill onsite, therefore it is not part of this extension request. For the reasons discussed below in Table 2-2, the following CCR wastestreams must continue to be placed in the CCR surface impoundments due to the lack of alternative capacity both on and off-site.

Table 2-2: Martin Lake CCR Wastestreams

CCR Wastestream	Average Flow (MGD)	Description	Luminant Notes
Bottom Ash (and non-CCR mill reject) sluice	13.14	Operated as closed-loop system with CCR sluiced to dewatering bins for solids removal before collecting flow in Ash Pond Area for reuse.	The water in this system is recycled from the Ash Pond Area (with makeup from the onsite non-CCR ponds) or sent to PDP5 as required to maintain the overall site water balance and avoid discharge of wastewater and site stormwater to Martin Lake. Since it contains CCR material, this stream cannot be routed to any location onsite other than the existing CCR surface impoundments and the volume is too large to be managed onsite in temporary tanks, which would not provide the necessary retention time for settling or space for solids management.
FGD Blowdown	4 [3.3 as overflow, 0.7 as underflow and filtrate (less solids)]	Purged to thickeners. Overflow returned to FGD system or NSP and underflow typically routed to solid waste handling system with solids removed and hauled to A-1 Area Landfill. The filtrate (non-CCR) is then returned to the NSP. Underflow can be routed to PDP5 from the NSP when solid waste handling system is down for maintenance or when upset conditions occur in the process.	Water from the NSP is currently recycled to the FGD system through the wastewater recycling facility. The intermittent purges of CCR solids from the system during upsets or maintenance events cannot be routed to another location onsite outside the Ash Pond Area or PDP5. Once the EAP retrofit is completed in Fall of 2020, and prior to the April 11, 2021 deadline, Luminant will be able to reroute the filtrate to the retrofitted EAP rather than the unlined NSP during normal operation; however, this wastestream may need to be managed in the other unlined portions of the Ash Pond Area and PDP5 if there are any upset conditions or significant rain events that require additional storage capacity.

2.1.2 Non-CCR Wastestreams

Luminant evaluated each non-CCR wastestream placed in the Martin Lake CCR surface impoundments. For the reasons discussed below in Table 2-3, each of the following non-CCR wastestreams must continue to be placed in the CCR surface impoundments due to lack of alternative capacity both on and off-site.

Table 2-3: Martin Lake Non-CCR Wastestreams

Non-CCR Wastestream	Average Flow (MGD)	Description	Luminant Notes
Air Pre-heater Wash Water	Outage Only	Wash water	Once the EAP retrofit is completed in Fall of 2020, and prior to the April 11, 2021 deadline, Luminant will reroute this wash water to the retrofitted EAP; however, this wastestream may need to be managed in the other unlined portions of the Ash Pond Area and PDP5 if there are any upset conditions or significant rain events that require additional storage capacity.
Boiler Non-Chemical Metal Cleaning Wastewater	Outage Only	Wash water from fireside and back-pass washes. Typically sluiced to dewatering bins for solids removal before collecting flow in Ash Pond Area for reuse. As required based on storage capacity and rainfall levels, these flows may be transferred from the Ash Pond Area to PDP5.	Once the EAP retrofit is completed in Fall of 2020, and prior to the April 11, 2021 deadline, Luminant will reroute this wash water to the retrofitted EAP; however, this wastestream may need to be managed in the other unlined portions of the Ash Pond Area and PDP5 if there are any upset conditions or significant rain events that require additional storage capacity.
Misc. Process Wastewater and Stormwater	Unknown/ Not Metered	Includes Boiler Blowdown, Boiler Room Sump Flows, Demineralizer Regeneration Flows, Reverse Osmosis System Reject Flows, Other Water Treatment Wastewaters, Miscellaneous Plant Drains (wash water), Stormwater from solids handling area, and Boiler Chemical Cleaning Wastewater (typically only final rinses). Can periodically receive Lignite and Coal Pile Runoff and Stormwater Runoff from the site Stormwater Pond during rain events and Oil Water Separator and Limestone area runoff from the Low Volume Wastewater Pond.	These flows are routed to the Ash Pond Area (and potentially from the Ash Pond Area to PDP5) via yard sumps and drains. If these wastestreams are no longer managed in the CCR impoundments, it would require major modifications to the wastewater permit and the development of additional storage and treatment system capacity which would extend the overall compliance schedule.

2.1.3 Site-Specific Conditions Supporting Alternative Capacity Approach – § 257.103(f)(1)(iv)(A)(1)(i)

As shown on Figure 1 in Appendix A, Martin Lake is landlocked with the Martin Creek Reservoir located on the north, east, and south sides of the plant. The western boundary is formed by residential properties and mining operations as shown in Figure 1. Much of the site that is outside the floodplain is occupied with critical infrastructure including the lignite/coal storage piles, the switchyard, transmission lines, the solids handling area, and the existing site impoundments. The limited space and congestion in and around the solids handling areas does not provide sufficient space for the construction of a new pond(s) or temporary tanks to manage and store the CCR and non-CCR wastestreams.

The four CCR surface impoundments receive both the CCR sluice flows and various non-CCR wastewater wastestreams produced onsite. In addition to providing treatment for the reduction of total suspended solids, the CCR impoundments are also a critical component in the management of the overall site water balance.

The typical operation and management of the CCR ponds for the past several decades has been that one pond is generally out-of-service to allow for solids removal. Ordinarily, it takes 6-8 months of out-of-service time to complete solids removal. If additional work for maintenance or repairs is needed, the out-of-service period is often extended.

If a pond is out-of-service for a simple clean-out, the clean-out operations can be ceased and the pond quickly returned to service temporarily if necessary due to unplanned operational events or heavy rainfall; however, if the pond requires liner repairs or replacement it is critical to the project to complete all the necessary repairs or replacement before the pond is returned to service. This means that during a project involving a liner retrofit, water balance becomes critical and sometimes requires extraordinary management effort.

Performing the retrofit operation sequentially to have one pond out-of-service at any given time provides the operational flexibility and adequate pond space for upset conditions, such as above average rainfall events or periods or unscheduled unit shutdowns. Furthermore, the retrofit work must be completed in the summer months, outside of the typical wet months and the spring and fall outages that occur at the Martin Lake site.

In the summer of 2015, Luminant hired Burns & McDonnell to evaluate the overall plant water balance to estimate the impacts associated with taking impoundments out of operation during various operational scenarios. The evaluation was in preparation for the possible seasonal operation of the generating units.

Since the primary means of maintaining the site water balance is associated with plant operation and evaporation in both the FGD and bottom-ash transport water systems, this operational mode with the plant and both the FGD and bottom-ash transport systems shut down or operating at reduced loads during the shoulder months (coincident with the periods that typically include the heaviest rainfall) caused significant concern. For the primary case considered in 2015, the site was forecasted to operate with a positive water balance, taking on additional water volume between October and May of each year and a negative water balance with the units in seasonal operation between June 1 and September 30 (assuming a 74% capacity factor during this season). The change to seasonal operation did not occur, but some of the information developed in that evaluation is useful in describing the importance and need for ponds to provide adequate space to accommodate upset or heavy rainfall periods, and management of solids in the ponds.

The design storage capacity of the Martin Lake CCR impoundments are summarized in Table 2-4. The available storage capacity at any point in time is impacted by the accumulation of solids in the impoundments, as well as the ever-changing amount of stormwater and process water contained in the pond system.

Table 2-4: Summary of Pond Design Storage Capacity

Impoundment	Design Volume (gal)
EAP	43,000,000
WAP	70,000,000
NSP	58,000,000
PDP5	66,000,000
Low Volume Retention Pond	49,550,000
Storm Water Retention Pond	34,300,000
Total Capacity (gal)	320,850,000

The largest single uncontrolled input into the site water balance is rainfall. The Martin Lake facility is located near the eastern border of Texas in a region known as the Piney Woods. This region is characterized by wet springs, then dry summers with rainfall returning in the fall. The typical average annual rainfall for the area of 46 to 50 inches, but can be highly variable from year to year because of the inflow of the humid Gulf Coast air from the south, dry and/or cool frontal activity from the north, and the occasional hurricane or tropical storm. Located over 12 miles from the nearest weather station at the East Texas Regional Airport, and subject to locally heavy rainfalls, the Martin Lake facility has monitored and recorded its own

rainfall data since 1978. In the 41-year site rainfall record (1978 – 2019) of the site, the average annual rainfall is 47.98 inches, with a minimum of 27.34 inches in 2010, and a maximum of 74.40 inches in 2018.

The Martin Lake facility captures and controls the rainfall runoff from approximately 180 acres of the plant site. This includes 97 acres of direct rainfall into the ponds and 83 acres from areas that have exposed materials such as coal or other materials, including the solids handling area, secondary containments, and buildings, roads, etc., in these areas. Of the 83 non-pond acres, the runoff coefficient is normally estimated at 85% for the first 0.50 inches of rain due to the impermeable nature of the materials, surfaces, and compacted soils. After the first 0.50 inches of rain from a single event or a series of close events, the runoff coefficient rises to an estimated 95-100%. Other factors affect the estimated coefficients, including rainfall duration, time since last rainfall, ambient temperature, etc. For a 1- inch rainfall, the Martin Lake site usually gains ~ 4.6 million gallons of water into its wastewater management systems. Over the course of an average year (e.g., ~48 inches of rainfall), the site gains 220 million gallons, or 675-acre feet, which is over 65% of the total storage volume of all ponds on-site.

The rainfall event most often identified as the standard for water management purposes is the “10-year, 24-hour rainfall event,” as defined by the National Weather Service in Technical Paper No. 40, “Rainfall Frequency Atlas of the United States,” May 1961. For the Martin Lake site, the 10-year/24-hour event is estimated at 7.1 inches; 34 million gallons or 105-acre feet at a 100% runoff coefficient. A 25-year/24-hour event is sometimes recommended for planning and adds approximately 1 inch or an additional 4.6 million gallons. The highest total monthly rainfall for the months of May through August from onsite records, is 15.60 inches or over 76 million gallons (June 1993).

2.1.4 Impact to Plant Operations if Alternative Capacity Not Obtained – § 257.103(f)(1)(iv)(A)(1)(ii)

As indicated in Table 2-4, removing any more than one of the CCR impoundments from service would significantly reduce the storage capacity of the site pond system by over 30%. The remaining impoundments onsite (low volume wastewater retention pond, and stormwater retention pond) do not typically have space to independently store and/or treat a 10-year/24-hour rainfall event (due to water already present in the ponds that are never emptied, and due to solids accumulation over time) with more than one of the CCR ponds out-of-service. This is because the loss of storage space from any one CCR pond adds to the volume that must be handled by the remaining ponds. It also increases the volume that must be managed by the CCR ponds that are in service in order to maintain segregation of potential CCR contact waters. Any significant rainfall during the period where more than one impoundment is out of

service for retrofit construction would create insurmountable water balance concerns and wastewater management/permit issues.

In addition to the TPDES wastewater permit limitation on selenium (discussed above), there are also other permit limitations that do not allow the reroute of certain non-CCR wastestreams from the CCR ponds to the non-CCR ponds. This makes it impossible to remove more than one of the CCR ponds at the same time while a generating unit is in operation.

To maintain reliable generation and sufficient water storage to sustain zero discharge during average and heavy rainfall events, the plant must operate a minimum of three out of the four CCR surface impoundments.¹ Specifically, for the plant to continue operating and generating electricity during retrofit work, the CCR impoundments will require sequential retrofitting to consist of diverting all wastestreams from the impoundment to be retrofitted by pumping water to the other impoundments, removing CCR materials (bottom ash or FGD solids) for disposal in the A-1 Area landfill, relining the impoundment, returning the impoundment to service, and starting the next impoundment retrofit. All of this must take into consideration typical and possibly atypical wet weather conditions.

2.1.5 Options Considered Both On and Off-Site to Obtain Alternative Capacity

As EPA explained in the preamble of the 2015 rule, it is not possible for sites that sluice CCR material to an impoundment to eliminate the impoundment and dispose of the material offsite. *See* 80 Fed. Reg. 21,301, 21,423 (Apr. 17, 2015) (“[W]hile it is possible to transport dry ash off-site to [an] alternate disposal facility that is simply not feasible for wet-generated CCR. Nor can facilities immediately convert to dry handling systems.”). Luminant agrees with EPA in this assessment and confirms that off-site alternatives are not an option for wet-generated CCR and wet-generated non-CCR wastestreams. At Martin Lake, all dry-handled CCR wastestreams are currently disposed of in the A-1 Area landfill onsite. Consequently, there are no feasible offsite-disposal options for the wet-generated wastestreams at Martin Lake. The only feasible onsite alternatives involve continued use of the CCR surface impoundments at Martin Lake.

The options considered for alternative disposal capacity of the wastestreams currently routed to the Martin Lake CCR surface impoundments are summarized in Table 2-5. Additional details on the CCR and non-CCR wastestreams included in this demonstration request are found in Table 2-2 and Table 2-3, respectively.

¹ As EPA recognized in the final rule, “[t]he Martin Lake circumstances are unique in that the facility plans to retrofit four impoundments, and each retrofit must occur sequentially because the facility requires a minimum of three impoundments to be operating at any one time in order for the plant to operate.” 85 Fed. Reg. at 53,528.

Table 2-5: Martin Lake Alternatives for Disposal Capacity

Alternative Capacity Technology	Average Time (Months)¹	Feasible at Martin Lake?	Selected?	Luminant Notes
Conversion to dry handling	33.8	Yes	No	A dry bottom ash conversion could be performed; however, the duration is expected to take longer than the CCR impoundment retrofits and would delay the removal of CCR materials from the unlined impoundments until this conversion is completed. Furthermore, Martin Lake would still require large volumes of storage for the stormwater and other non-CCR wastestreams onsite, which would require the use of real estate currently occupied by the CCR surface impoundments.
Non-CCR wastewater basin	23.5	No	No	This option only provides a partial solution since the CCR wastestreams cannot be directed to non-CCR basins. Furthermore, the volume of non-CCR wastestreams cannot be contained within the non-CCR basins that exist onsite without discharge, and there is not adequate real estate onsite to construct additional non-CCR basins for the storage of non-CCR wastestreams only.
Wastewater treatment facility	22.3	No	No	Due to Martin Lake practices for recycling water within the plant, building a treatment system (such as chemical precipitation, settling ponds, or concrete tanks) to remove solids would not assist with overall storage volume needs for stormwater and process water management at the Martin Lake site (hundreds of millions of gallons required).
New CCR surface impoundment	31	No	No	There is not adequate real estate onsite within a reasonable distance of the power block to construct a new CCR surface impoundment that could manage and store the plant's wastestreams. This option would also delay the removal of CCR materials from the unlined impoundments until this construction is completed.
Retrofit of a CCR surface impoundment	29.8	Yes	Yes	This alternative maintains required water storage onsite and accelerates the removal of CCR material from the unlined impoundments earlier than all other options considered.
Multiple technology system	39.1	No	No	Any multi-technology solution would require hundreds of millions of gallons of storage for non-CCR wastestreams and stormwater management. There is not adequate footprint available onsite for this storage outside the area currently occupied by the CCR surface impoundments.

Alternative Capacity Technology	Average Time (Months) ¹	Feasible at Martin Lake?	Selected?	Luminant Notes
Temporary treatment system	Not defined	No	No	Given the size of the wastestreams that would need to be managed and the non-CCR wastewater storage capacity needed to replace the CCR surface impoundments at Martin Lake, temporary treatment systems are not practical. Luminant has chosen to focus on implementing the necessary measures for the retrofit of the Martin Lake CCR surface impoundments rather than try to develop temporary tank-based storage for all wastestreams.

¹From Table 3. See 85 Fed. Reg. at 53,534.

2.1.6 Approach to Obtain Alternative Capacity

Due to the overall water management needs of the facility, including storage of CCR and non-CCR wastestreams generated at the site, the only viable solution for alternative disposal capacity involves a sequential retrofit of the existing CCR surface impoundments pursuant to the retrofit criteria in 40 C.F.R. § 257.102(k). As discussed in more detail in Section 2.1.3, there is not enough site footprint available to construct a new CCR surface impoundment outside the boundary of the existing impoundments, and even if dry bottom ash handling systems were installed at Martin Lake, the plant would continue to require the surface area and the volume of the existing impoundments for evaporation and water management at the site. Consequently, even if a dry bottom ash handling system was installed, a similar retrofit activity (removal of CCR material and installation of a new liner system) to manage non-CCR wastestreams would still be required and the dry ash conversion project would likely only extend the schedule required for the overall project.

As shown on the schedule in Appendix B, Luminant has been taking steps to address the CCR surface impoundments at Martin Lake since 2015. Luminant hired Burns & McDonnell to evaluate the steps necessary to comply with the CCR Rule published in April 2015. Burns & McDonnell also evaluated the overall plant water balance to estimate the impacts associated with taking impoundments out of operation during various operational scenarios. Luminant cannot remove more than one of its CCR surface impoundments from service at a time to perform retrofit activities (see Section 2.1.4).

Luminant installed monitoring wells in September of 2015 and performed background groundwater sampling from October of 2015 to December of 2016. During this time, several engineering firms assisted Luminant in preparing the required CCR compliance documentation, which Luminant posted on its public

CCR website. Key information is summarized in Table 2-1. As indicated in Luminant's CCR compliance documents, the Martin Lake CCR impoundments comply with the location restrictions, the required safety factors and stability assessments were satisfied, and the impoundments were deemed to be low hazard facilities.

In February 2019, after beryllium, cobalt, and lithium were first identified at statistically significant levels (SSL) above the groundwater protection standards (GWPS), Luminant issued an RFP for engineering services to support the retrofit activities of the Ash Pond Area. HDR was awarded the scope to evaluate retrofit alternatives and design the selected solution. HDR investigated alternatives to perform the retrofit as follows:

1. Retrofit the EAP, Subdivide and Retrofit the WAP, and Decommission the NSP
2. Retrofit the EAP, Subdivide and Retrofit the NSP, and Decommission the WAP
3. Retrofit the EAP, WAP, and NSP (maintaining the existing footprint/storage capacity)
4. Retrofit the EAP, Subdivide and Retrofit the WAP, and Cap-in-Place the NSP

Each alternative, except for Alternative 3, requires elimination of a portion of the CCR surface impoundment area available to the plant, which would reduce the water storage capacity and result in water balance issues, as summarized in Section 2.1.4. Each alternative, except for Alternate 3, also requires construction of intermediate berms within the CCR impoundment footprint, which would extend the permitting and construction schedule for the project and further reduce the usable volume of the impoundments. Consequently, Luminant has selected Alternative 3 to retrofit all three impoundments in the Ash Pond Area in sequence. Each of these impoundments are currently lined with a 4" concrete revetment mat, two layers of HDPE geomembrane material that sandwich a drainage net or geocomposite material, and various thicknesses of underlying clay soils. As discussed in the retrofit plan prepared by HDR pursuant to 40 C.F.R. § 257.102(k), and posted to Luminant's CCR website, the retrofit project includes leaving this existing liner system in place and retrofitting in the following general sequence for each impoundment, beginning with the EAP in 2020, and then progressing to the WAP in 2021 and the NSP in 2022:

- Remove any CCR material, rocks, and other sediment from the pond. The material will be loaded on railcars for transport to the Martin Lake A-1 Area Landfill.
- Clean the existing concrete revetment mat surface, by washing with water from the adjacent operating ponds and returning both the wash water and sediment to the operating ponds.

- Load and haul general soil fill material from the Owner's stockpile located at Liberty Mine. This stockpile is located approximately 4.5 miles from the Ash Pond Area. This pile may be relocated as required to support mining operations.
- Place the general fill material over the existing concrete revetment to a depth of at least six (6) inches, nominally compact it, and smooth roll to finish the installation. This material will provide the soil buffer/grading layer above the existing concrete surface as referenced in the facility retrofit plan.
- Install a composite liner system including a geosynthetic clay liner (GCL) with a maximum hydraulic conductivity of 1×10^{-9} cm/sec overlain by a 60-mil high-density polyethylene (HDPE) geomembrane, as specified in 40 C.F.R. § 257.70(b).

As shown in Table 2-4, PDP5 provides a significant amount of the excess site storage capacity and must be used to receive CCR and non-CCR wastestreams during the retrofit of the Ash Pond Area. Once the Ash Pond Area is retrofitted and returned to service, PDP5 may be retrofitted beginning in July of 2023 (following the wet spring months and spring outage season that requires increased water storage capacity compared to the summer months at Martin Lake) or, alternatively, PDP5 may qualify for the alternate liner demonstration under the anticipated Part B CCR Rule, which will be evaluated as a compliance option by Luminant once the rule is finalized.

2.1.7 Technical Infeasibility of Obtaining Alternative Capacity prior to April 11, 2021

Luminant began designing the retrofit of the Ash Pond Area impoundments in early 2019. The retrofit of the first of three impoundments (EAP) will be completed in Fall of 2020. The remaining two impoundments within the Ash Pond Area will be completed sequentially after the first retrofit is complete, and Luminant and its contractors are anticipating this work to be completed for one pond in each calendar year. PDP5 will be retrofitted with a composite liner following completion of the Ash Pond Area retrofit (unless it qualifies for an alternate liner demonstration under the future Part B Rule). No more than one impoundment can be removed from service at a time without reducing the site water storage capacity below the necessary minimum levels for continued intermittent operation without discharge from the site pond system, and additional storage and treatment system capacity would need to be installed and the discharge permit modified if continued discharge were required. Consequently, it is not possible to implement the measures discussed above in a way that would likely be successful by April 11, 2021.²

² As EPA recognized in the final rule, “[t]he Agency intends for unique circumstances like Martin Lake to be addressed through the alternative closure provisions of the final rule.” 85 Fed. Reg. at 53,528.

2.1.8 Justification for Time Needed to Complete Development of Alternative Capacity Approach – § 257.103(f)(1)(iv)(A)(1)(iii)

The schedule for developing alternative disposal capacity is described in more detail in Sections 2.2 and 2.3. The milestones for progress are summarized in Table 2-6 below. Luminant believes this represents the fastest technically feasible timeframe for compliance at Martin Lake, and these durations are consistent with EPA’s assessment that 12 months accurately reflects the amount of time needed to retrofit a single surface impoundment. *See* 85 Fed. Reg. at 53,529.

Table 2-6: Retrofit Project Progress Milestones

Year or Progress Reporting Period	Status	Milestone Description	Luminant Notes
2019	Completed	Evaluate retrofit scenarios, Complete Design Activities	Luminant began design of the retrofit solution in early 2019.
2020	Completed	Bid and Award construction contract for EAP retrofit, Submit Demonstration under 257.103(f)(1) requesting extension of the deadline to cease placing wastestreams into WAP, NSP, and PDP5	The construction of the first pond retrofit (EAP) is underway and will be completed in Fall of 2020, prior to the April 11, 2021 deadline.
2020	On Schedule	Complete retrofit of the EAP, Begin Dewatering/CCR Removal from WAP	
April 30, 2021	Scheduled	Bid and Award construction contract for WAP retrofit, Continue removal of solids from WAP	The second impoundment retrofit (WAP) will begin with removal operations by the plant staff prior to the April 11, 2021 deadline as long as the site does not experience heavy rain events this spring coincident with significant unit outages that may require temporary use of the WAP for wastewater or stormwater storage. At this point, the majority of CCR flows will be routed to the EAP and the NSP and PDP5 will continue to provide storage for excess CCR and non-CCR wastestreams and stormwater.
October 31, 2021	Scheduled	Complete removal of CCR from WAP, Complete construction of WAP retrofit (other than punchlist items), Begin Dewatering/CCR Removal from NSP	The WAP construction is forecasted to be completed within this calendar year. NSP CCR removal operations will initiate as allowed by weather.

Year or Progress Reporting Period	Status	Milestone Description	Luminant Notes
April 30, 2022	Scheduled	Continued CCR Removal from NSP, Bid and Award construction contract for NSP retrofit, submit alternate liner demonstration for PDP5	At this point, flows will be concentrated to the retrofitted EAP and WAP as well as PDP5 (the eligible unlined CCR surface impoundment) providing the site does not experience heavy rain events this spring coincident with significant unit outages that may require temporary use of the NSP for wastewater or stormwater storage.
October 31, 2022	Scheduled	Complete construction of NSP retrofit and begin potential detailed design for PDP5 retrofit	Luminant is projecting that retrofit activities for the Ash Pond Area can be completed by November 1, 2022. This is subject to delays primarily associated with the unknown efficiency of dewatering/dredging of scrubber solids from the NSP.
July 1, 2023	TBD (depends on Part B)	Begin retrofit for PDP5	PDP5 would cease receiving wastestreams on July 1, 2023, and begin retrofit if it does not qualify for alternate liner demonstration.

2.2 Detailed Schedule to Obtain Alternative Disposal Capacity - § 257.103(f)(1)(iv)(A)(2)

The required visual timeline representation of the schedule is included in Appendix B of this demonstration and described further in Section 2.3 below.

2.3 Narrative of Schedule and Visual Timeline - § 257.103(f)(1)(iv)(A)(3)

The third section for the workplan is a “detailed narrative of the schedule and the timeline discussing all the necessary phases and steps in the workplan, in addition to the overall timeframe that will be required to obtain capacity and cease receipt of waste.” 85 Fed. Reg. at 53,544. As EPA explained in the preamble to the Part A rule, this section of the workplan must discuss “why the length of time for each phase and step is needed, including a discussion of the tasks that occur during the specific stage of obtaining alternative capacity. It must also discuss the tasks that occur during each of the steps within the phase.” 85 Fed. Reg. at 53,544. In addition, the schedule should “explain why each phase and step shown on the chart must happen in the order it is occurring and include a justification for the overall length of the phase” and the “anticipated worker schedule.” 85 Fed. Reg. at 53,544. EPA notes the overall “discussion of the schedule assists EPA in understanding why the time requested is accurate.” 85 Fed. Reg. at 53,544.

As described in Section 2.1.6, the CCR surface impoundments must be retrofitted sequentially, with no more than one impoundment undergoing retrofit at any point in time, and preferably during the summer months while the units are operating and evaporating any excess water that could accumulate. These periods

require the least total water storage capacity to maintain zero discharge operations at the site. This start date is subject to delays caused by significant rain events as well as any prolonged outages at the plant.

Based on the estimated durations shown in Appendix B, each impoundment retrofit will require a minimum of one construction season for completion. The following paragraphs outline the scope required for the retrofit of each impoundment in the Ash Pond Area. The design drawings, which include additional scope definition for each impoundment, are included in Appendix C (EAP), Appendix D (WAP), and Appendix E (NSP). The design for the PDP5 retrofit will be completed if required following the determination of the facility's alternate liner status. This Demonstration seeks a site-specific alternative deadline to initiate retrofit of the last unlined impoundment at the Martin Lake site (PDP5). The construction activities for the PDP5 retrofit are not included within this Demonstration as they will occur after the requested deadline for the Martin Lake site (if required at all following Luminant's review of the future Part B Rule).

EAP Retrofit Activities: As noted on the schedule in Appendix B, the construction contract for the EAP retrofit has been awarded. Luminant removed nearly all the CCR material in 2019 and the retrofit construction is essentially complete. The durations shown on the project schedule match the estimates developed by the selected construction contractor and experienced on the EAP retrofit to date. These durations are based on an average work schedule of six days per week, are subject to delays caused by significant rain events, and are based on the following scope of work which must be performed in the sequence listed below:

- Contractor shall order necessary materials and mobilize to the site. The lead time for the liner materials and the piping are shown on the Appendix B schedule and are based on feedback from suppliers and confirmed by the construction contractor.
- Contractor shall remove any remaining CCR material, rocks, and sediment from the EAP, and haul and stockpile this material at the Decant Basin. Luminant will load the stockpiled material onto rail cars for disposal at the Martin Lake A-1 Area Landfill. This effort is referred to as Site Preparation on the Appendix B schedule and has been completed for the EAP.
- Contractor shall use water from the adjacent WAP or NSP to wash remaining CCR material off the sides and floor of the EAP and remove the material. The existing revetment mat within the EAP will be visually inspected to confirm CCR material, rocks and sediment have been removed. This effort has been completed for the EAP.
- Contractor shall load and haul general soil fill material from the stockpile located at Liberty Mine. This stockpile is located approximately 4.5 miles from the EAP. Contractor shall place the general

fill material over the existing concrete revetment to a depth of at least six (6) inches, nominally compact it, and smooth roll to finish the installation. This activity is complete.

- Contractor shall load and haul the remaining general soil fill material from the stockpile located at Liberty Mine to the location identified as the “Temporary Stockpile Location” south of PDP 5 (see Appendix C Drawings). Upon completion, Contractor shall seed the stockpile and install erosion control measures, such as silt fencing, at the stockpile. This activity will continue as needed, to avoid delays in the overall project schedule, but does not need to be completed prior to any other critical activities. The stockpiled material, either from the mine or this temporary location, will be used to support the subsequent WAP and NSP retrofit activities.
- Contractor shall install a GCL over the sides and floor of the EAP and secure it in a perimeter anchor trench.
- Contractor shall install a 60-mil HDPE liner directly on the GCL and secure it in a perimeter anchor trench. This occurred at the same time as the GCL placement, lagging slightly behind it but overlapping. Consequently, these activities are shown on the same timeline in Appendix B. As shown in Appendix C, the GCL and the membrane are also attached to piping (air vents and dewatering line) with pipe boots and are battened to the concrete structures within the impoundment during this installation period.
- Contractor shall modify the existing 48-inch suction line on the south end of the pond by increasing the screened area as shown in the plans (see Appendix C Drawings). This activity is complete.
- Contractor shall install all 12-inch HDPE pipe as shown in the plans. Each pipeline will start at its corresponding isolation valve previously installed by Luminant. This work has been completed so the new lines can be placed into service prior to returning any water to the EAP and to allow for full function of the plant recycle systems once the WAP and eventually NSP are removed from service for retrofitting. As shown in Appendix C, this piping is anchored to a concrete slab that is tied into the new EAP impoundment liner and will not create a new liner penetration. Approximately 5,400 linear feet of piping was rerouted or added as part of this project.
- The Contractor shall pump off stormwater as necessary from the EAP to the WAP during construction. This is an ongoing activity that will be required following each rain event during the construction period. Consequently, it is not shown on the construction schedule.
- Upon completion, Luminant will post the required notification of retrofit completion and resume operation of the EAP, likely by transferring the water from the WAP so CCR material removal efforts can progress more efficiently at that facility.

WAP Retrofit Activities: As noted on the schedule in Appendix B, the design is completed for the WAP retrofit; however, the construction contract has not been bid or awarded at this time. This procurement effort will be completed in time to support construction of the WAP retrofit (planned for July 2021), after the spring rainfall periods when the storage capacity required at Martin Lake is reduced by the peak summer operation of the generating units. Luminant began removing a majority of the CCR material during the 2020 summer operational period and will continue once the impoundment is dewatered (after the EAP is placed into service); however, any significant rain events that occur in the fall of 2020 through the spring of 2021 may need to be diverted to the WAP as required. The remaining durations shown on the project schedule are based on the estimated durations and work schedule received from the EAP construction contractor and have been adjusted based on the estimated quantity differences between the EAP and the WAP. The WAP retrofit includes the following scope of work, which must be performed in the sequence listed below:

- Contractor shall order necessary materials and mobilize to the site.
- Contractor shall remove any remaining CCR material, rocks, and sediment from the WAP, and haul and stockpile this material at the Decant Basin. Luminant will load the stockpiled material onto rail cars for disposal at the Martin Lake A-1 Area Landfill.
- Contractor shall use water from the adjacent EAP or NSP to wash remaining CCR material off the sides and floor of the WAP and remove the material. The WAP will be visually inspected to confirm CCR material, rocks and sediment have been removed.
- Contractor shall load and haul general soil fill material from the stockpile, which will have been relocated adjacent to PDP5. Contractor shall place the general fill material over the existing concrete revetment to a depth of at least six (6) inches, nominally compact it, and smooth roll to finish the installation. This activity must be completed after the existing revetment mat is inspected and confirmed to be free of CCR material but before the liner system can be placed.
- Contractor shall install a GCL over the sides and floor of the WAP and secure it in a perimeter anchor trench.
- Contractor shall install a 60-mil HDPE liner directly on the GCL and secure it in a perimeter anchor trench. This will occur at the same time as the GCL placement, lagging slightly behind it but overlapping. Consequently, these activities are shown on the same timeline. As shown in Appendix D, the GCL and the membrane will also be attached to piping (air vents and standpipe) with pipe boots and will be battened to the concrete structures within the impoundment during this installation period.

- The Contractor shall pump off storm water as necessary from the WAP to the EAP during construction. This is an ongoing activity that will be required following each rain event during the construction period. Consequently, it is not shown on the construction schedule.
- Upon completion, Luminant will post the required notification of retrofit completion and resume operation of the WAP, likely by transferring the water from the NSP so that CCR material removal efforts can progress more efficiently at that facility.

NSP Retrofit Activities: As noted on the schedule in Appendix B, the design is completed for the NSP retrofit; however, the construction contract has not been bid or awarded at this time. This procurement effort will be completed in time to support construction of the NSP retrofit beginning approximately July 2022, when the storage capacity required at Martin Lake is reduced by the peak summer operation of the generating units. Luminant will begin removing the CCR material during the summer 2021 operational period and the impoundment will be dewatered once the WAP is placed into service; however, any significant rain events that occur through the spring of 2022 will be diverted to the NSP as required to prevent discharge from the site. The durations shown on the project schedule are based on the estimated durations and work schedule developed by the EAP construction contractor and have been adjusted based on the estimated quantity differences between the EAP and the NSP. The contractor scope for the NSP retrofit is identical to the WAP except for the quantity differences and an additional pipe rack liner attachment. The design drawings for the NSP retrofit are included in Appendix E.

The CCR removal efforts at the NSP will be different than at the WAP. There is a similar amount of material in each pond; however, the scrubber sludge will be significantly more challenging to dewater and decant than the bottom ash fines. This leads to a longer removal schedule necessary to drain the material for excavation and decant the material (at the Decant Pad/Basins) prior to loading on rail cars. Even when dewatered, this material will be significantly wetter than the ash fines which may impact landfill operations during disposal. This operation will likely require a larger surface area to promote spreading and drying of the material prior to compaction, and that could impact the rate at which material can be hauled to the landfill. Luminant will provide ongoing schedule updates in the required semi-annual progress reports; however, this activity, along with any anticipated delays due to rain or delayed starts due to increased demand for water storage onsite, are the primary factors that could extend the schedule for this retrofit project.

PDP5 Retrofit Activities: Luminant intends to evaluate the Part B Rule requirements with respect to the alternate liner demonstration once the final rule is issued; however, since the final requirements and timeline of the Part B Rule are unknown, for purposes of this request, Luminant has assumed that the PDP5 retrofit

will be required and that this retrofit must follow the NSP retrofit in the same sequence described for the Ash Pond Area above. PDP5 cannot be removed from service until approximately July 1, 2023, following the spring outage season and typically wet spring months and coincident with summer peak operation so that plant operations can be sustained with the reduced pond capacity during the retrofit project. The schedule in Appendix B shows the design and construction procurement efforts being completed as required to meet this allowable construction period.

2.4 Progress Towards Obtaining Alternative Capacity - § 257.103(f)(1)(iv)(A)(4)

In the preamble to the final Part A rule, EPA explains that this “section [of the workplan] must discuss all of the steps taken, starting from when the owner or operator initiated the design phase all the way up to the current steps occurring while the workplan is being drafted.” 85 Fed. Reg. at 53,544. The discussion also must indicate where the facility currently is on the timeline and the processes that are currently being undertaken at the facility to develop alternative capacity. 85 Fed. Reg. at 53,545.

As shown in Appendix B and described in Section 2.1.6 and Table 2-6, Luminant has made considerable progress toward creating alternative disposal capacity for the CCR and non-CCR wastestreams at Martin Lake, specifically the Ash Pond Area units. Design for the retrofit project is complete, the required notification of intent to retrofit has been posted to Luminant’s CCR website for the Ash Pond Area, and construction of the EAP retrofit will be completed in the coming weeks as shown in Appendix B, prior to the April 11, 2021, deadline. Luminant has also started removing the CCR material from the WAP, and that effort is anticipated to be completed early next year.

3.0 DOCUMENTATION AND CERTIFICATION OF COMPLIANCE

To demonstrate that the criteria in 40 C.F.R. § 257.103(f)(1)(iii) has been met, the following information and submissions are submitted pursuant to 40 C.F.R. § 257.103(f)(1)(iv)(B) to demonstrate that the CCR surface impoundments at Martin Lake are in compliance with the CCR rule.

3.1 Owner's Certification of Compliance - § 257.103(f)(1)(iv)(B)(1)

In accordance with 40 C.F.R. § 257.103(f)(1)(iv)(B)(1), I hereby certify that, based on my inquiry of those persons who are immediately responsible for compliance with environmental regulations for the CCR Ash Pond Area and PDP5 at Martin Lake, the facilities are in compliance with all of the requirements contained in 40 C.F.R. Part 257, Subpart D – Standards for the Disposal of Coal Combustion Residuals in Landfills and Surface Impoundments. Martin Lake's CCR compliance website is up-to-date and contains all the necessary documentation and notification postings.

LUMINANT GENERATION COMPANY LLC

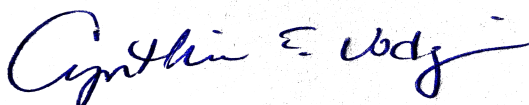

Cynthia Vodopivec
VP - Environmental Health & Safety
September 28, 2020

3.2 Visual Representation of Hydrogeologic Information - § 257.103(f)(1)(iv)(B)(2)

Consistent with the requirements of § 257.103(f)(1)(iv)(B)(2)(i) – (iii), Luminant has attached the following items to this demonstration:

- Map(s) of groundwater monitoring well locations in relation to the CCR unit (Appendix F1)
- Well construction diagrams and drilling logs for all groundwater monitoring wells (Appendix F2)
- Maps that characterize the direction of groundwater flow accounting for seasonal variations (Appendix F3)

3.3 Groundwater Monitoring Results - § 257.103(f)(1)(iv)(B)(3)

Tables summarizing constituent concentrations at each groundwater monitoring well for the Ash Pond Area and PDP5 are included as Appendix F4.

3.4 Description of Site Hydrogeology - § 257.103(f)(1)(iv)(B)(4)

A description of site hydrogeology and stratigraphic cross-sections of the site (including the Ash Pond Area and PDP5) are included as Appendix F5.

3.5 Corrective Measures Assessment - § 257.103(f)(1)(iv)(B)(5)

For the Ash Pond Area, the first assessment monitoring samples were collected in June 2018. The results, through the first 2020 semi-annual monitoring period, indicate the Ash Pond area is currently in assessment monitoring, with exceedances of the groundwater protection standards (GWPS) for beryllium, cobalt, and lithium first determined in January of 2019. Accordingly, pursuant to § 257.96, a corrective measures assessment report was prepared for the Ash Pond Area in September 2019 and is included as Appendix F6. For PDP5, detection monitoring has indicated statistically significant increases (SSIs) above the background concentrations; however, Luminant has completed successful alternate source demonstrations and the facility remains in detection monitoring. Accordingly, an assessment of corrective measures is not required for PDP5.

3.6 Remedy Selection Progress Reports - § 257.103(f)(1)(iv)(B)(6)

For the Ash Pond Area, selection of a remedy is underway. Accordingly, pursuant to § 257.97(a), semi-annual remedy selection progress reports were prepared for the Ash Pond Area on March 4, 2020, and September 3, 2020, and are included as Appendix F7. As noted above, an assessment of corrective measures and the resulting remedy selection efforts are not currently required for PDP5.

3.7 Structural Stability Assessment - § 257.103(f)(1)(iv)(B)(7)

Pursuant to § 257.73(d), the initial structural stability assessment report for Martin Lake was prepared in October 2016 and is included as Appendix F8. As required for compliance, another stability assessment will be completed in October 2021.

3.8 Safety Factor Assessment - § 257.103(f)(1)(iv)(B)(8)

Pursuant to § 257.73(e), the initial safety factor assessment report for Martin Lake was prepared in October 2016 and is included as Appendix F9. As required for compliance, another safety factor assessment will be completed in October 2021.

4.0 CONCLUSION

Based upon the information submitted in this demonstration, the Ash Pond Area and PDP5 at Martin Lake qualify for the site-specific alternative deadline for the initiation of closure as allowed by 40 C.F.R. § 257.103(f)(1).

Therefore, Luminant requests that EPA approve the demonstration and grant an alternative deadline of July 1, 2023, to allow for the continued placement of CCR and non-CCR wastestreams in the impoundments in the Ash Pond Area while those impoundments are retrofitted, for the continued use of PDP5 to receive CCR and non-CCR wastestreams throughout the Ash Pond Area retrofit project, and thereafter to begin retrofit of PDP5 if it does not meet the alternate liner demonstration allowed under the future Part B Rule. In that case, PDP5 would be retrofitted following the same sequence used for the Ash Pond Area. This retrofit work would initiate on July 1, 2023, following the wet spring months coincident with the spring outages when the maximum site water storage capacity is required. Luminant will update EPA on the project and any potential schedule impacts as part of the semi-annual progress reports required at 40 C.F.R. § 257.103(f)(1)(x), and if a need for a later compliance deadline is determined, Luminant will seek additional time as described in 40 C.F.R. § 257.103(f)(1)(vii).

APPENDIX A – SITE PLAN AND WATER BALANCE DIAGRAM

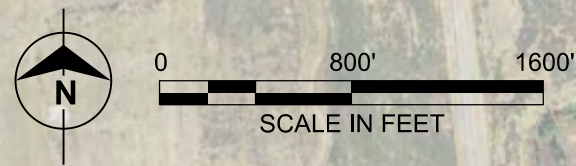
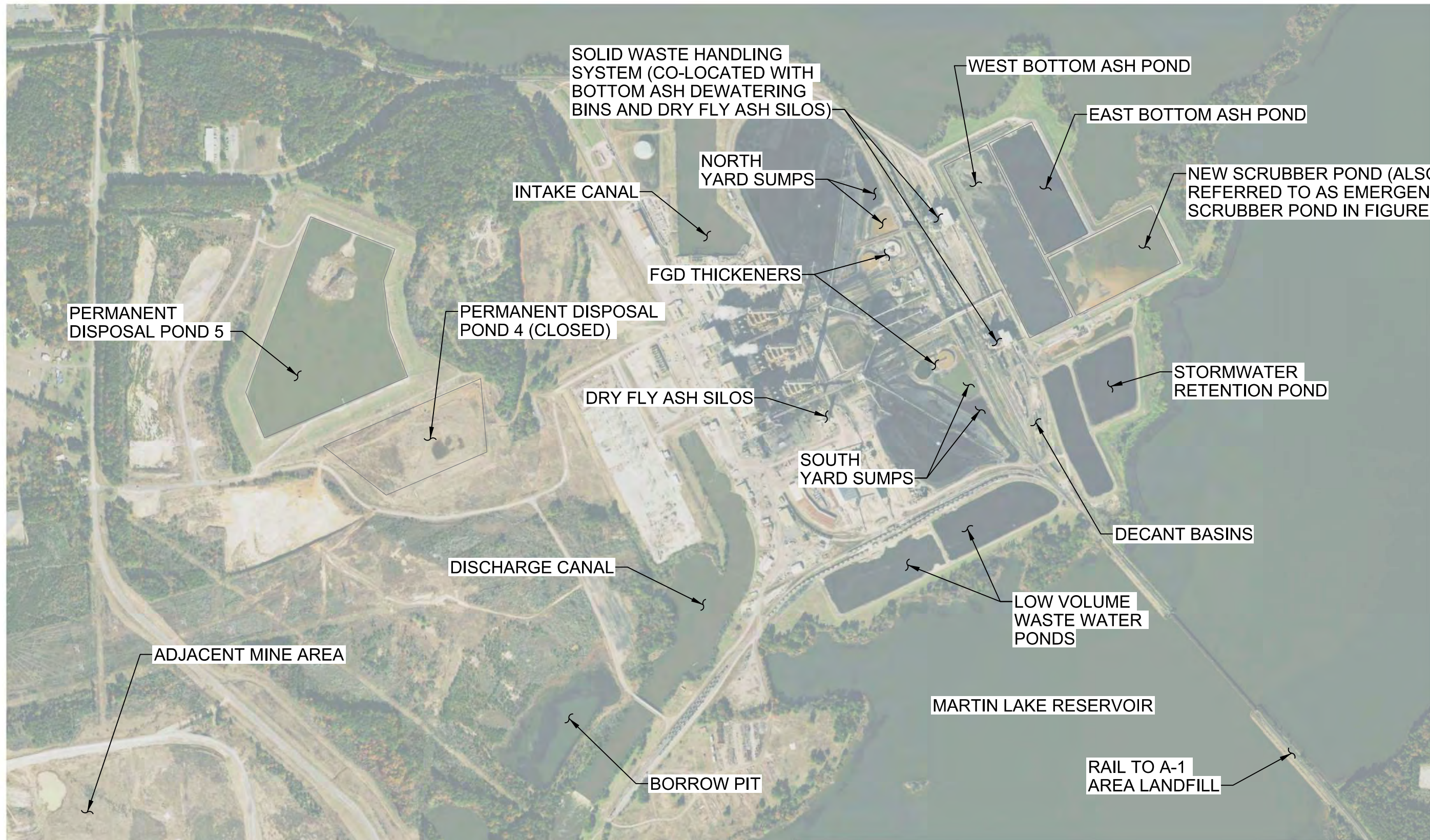

 date 4/7/2020 designed A. MYERS	LUMINANT MARTIN LAKE STEAM ELECTRIC STATION - SITE PLAN	project 122702
		contract -
		dwg FIGURE 1

Water Balance Diagram
Martin Lake Steam Electric Station
All flows in MGD unless stated otherwise

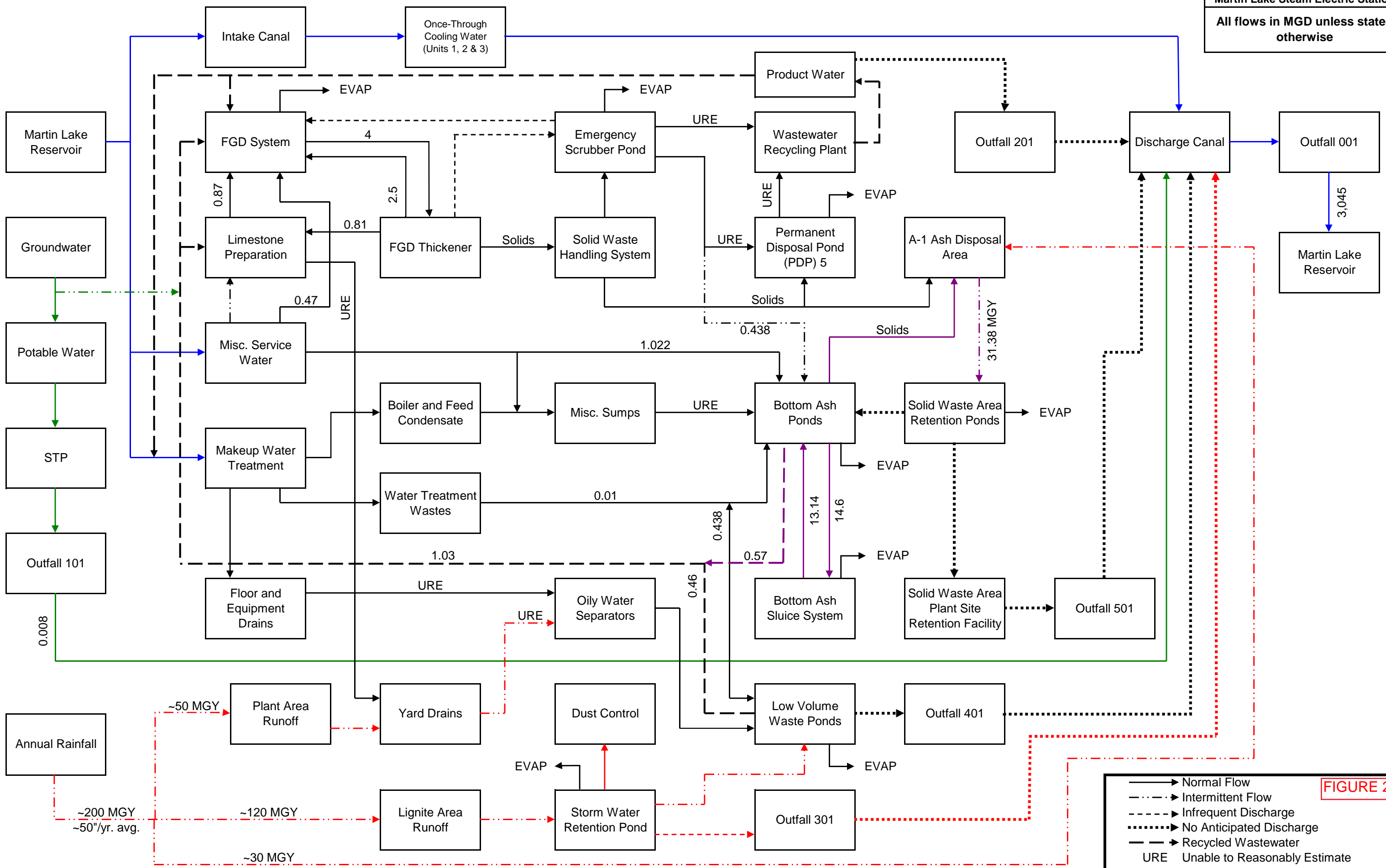

FIGURE 2

- Normal Flow
- - - -→ Intermittent Flow
- - - -→ Infrequent Discharge
-→ No Anticipated Discharge
- - - -→ Recycled Wastewater
- URE Unable to Reasonably Estimate

APPENDIX B – SCHEDULE

ID	Task Name	Duration	Start	Finish	Half 1, 2020					Half 2, 2020					Half 1, 2021					Half 2, 2021					Half 1, 2022					Half 2, 2022					Half 1, 2023											
					D	J	F	M	A	M	J	J	A	S	O	N	D	J	F	M	A	M	J	J	A	S	O	N	D	J	F	M	A	M	J	J	A	S	O	N	D	J	F	M	A	M
1	CCR Compliance Efforts	2116 days	Mon 3/23/15	Sun 4/30/23																																										
2	BMCD Retained by Luminant to Review CCR Compliance Impacts	95 days	Mon 3/23/15	Fri 7/31/15																																										
3	Final CCR Rule Published in Federal Register	0 days	Fri 4/17/15	Fri 4/17/15																																										
4	BMCD Completed Initial Water Balance Evaluation	94 days	Thu 7/2/15	Tue 11/10/15																																										
5	Luminant Installed Groundwater Monitoring Wells	12 days	Wed 9/9/15	Thu 9/24/15																																										
6	Background Groundwater Sampling	302 days	Mon 10/19/15	Tue 12/13/16																																										
7	BMCD Completed Liner Documentation	0 days	Fri 9/16/16	Fri 9/16/16																																										
8	BMCD Prepared Surface Impoundment History of Construction	0 days	Wed 10/5/16	Wed 10/5/16																																										
9	First Detection Monitoring Samples	0 days	Thu 9/21/17	Thu 9/21/17																																										
10	Ash Pond Area Assessment Monitoring Program - First Round	34 days	Tue 6/12/18	Fri 7/27/18																																										
11	Ash Pond Area Assessment Monitoring Program - Second Round	22 days	Fri 9/7/18	Mon 10/8/18																																										
12	Golder completed Successful Location Restriction Demonstration for Ash Pond Area and PDP 5	0 days	Wed 10/10/18	Wed 10/10/18																																										
13	SSL Determination/Notification - Ash Pond Area - Beryllium, Cobalt, and Lithium	23 days	Mon 1/7/19	Wed 2/6/19																																										
14	Ash Pond Area Assessment Monitoring Program - Third Round	24 days	Tue 5/14/19	Fri 6/14/19																																										
15	Ash Pond Area Assessment Monitoring Program - Fourth Round	24 days	Tue 9/10/19	Fri 10/11/19																																										
16	Corrective Measures Assessment for Ash Pond Area	87 days	Wed 5/8/19	Thu 9/5/19																																										
17	SSL Determination/Notification - Ash Pond Area - Beryllium and Cobalt	23 days	Thu 9/5/19	Mon 10/7/19																																										
18	EPA Released Proposed Draft ELG Rule and CCR Holistic Approach to Closure Part A Rule	0 days	Mon 11/4/19	Mon 11/4/19																																										
19	Public Meeting to review Corrective Measures Assessment	0 days	Wed 11/13/19	Wed 11/13/19																																										
20	SSL Determination/Notification - Ash Pond Area - Beryllium and Cobalt	22 days	Wed 1/8/20	Thu 2/6/20																																										
21	EPA Released Proposed Draft CCR Holistic Approach to Closure Part B Rule	0 days	Wed 2/19/20	Wed 2/19/20																																										
22	Retrofit Plan Published	0 days	Fri 2/28/20	Fri 2/28/20																																										
23	Semiannual Remedy Selection Progress Report Posted	0 days	Wed 3/4/20	Wed 3/4/20																																										
24	Notification of Intent to Retrofit the Ash Pond Area	0 days	Mon 6/29/20	Mon 6/29/20																																										
25	Semiannual Remedy Selection Progress Report Posted	0 days	Thu 9/3/20	Thu 9/3/20																																										
26	Semi-Annual Progress Report #1	0 days	Fri 4/30/21	Fri 4/30/21																																										
27	Semi-Annual Progress Report #2	0 days	Sun 10/31/21	Sun 10/31/21																																										
28	Semi-Annual Progress Report #3	0 days	Sat 4/30/22	Sat 4/30/22																																										
29	Semi-Annual Progress Report #4	0 days	Mon 10/31/22	Mon 10/31/22																																										
30	Notification of Completion of Retrofit - Ash Pond Area	0 days	Thu 12/1/22	Thu 12/1/22																																										
31	Semi-Annual Progress Report #5 (if required for PDP5)	0 days	Sun 4/30/23	Sun 4/30/23																																										
32	Impoundment Retrofit - Engineering and Procurement Efforts	823 days	Wed 2/13/19	Fri 4/8/22																																										
33	Bid and Award Engineering Services for Ash Pond Area Retrofit Project	67 days	Wed 2/13/19	Thu 5/16/19																																										
34	HDR Performed Alternatives Analysis for Ash Pond Area Retrofit Project	98 days	Fri 5/17/19	Tue 10/1/19																																										
35	HDR Detailed Design: Prepared Ash Pond Area (EAP, WAP, and NSP) Retrofit Bid Documents	87 days	Tue 10/1/19	Wed 1/29/20																																										
36	HDR Performed Alternatives Analysis for PDP 5 Retrofit Project	68 days	Mon 12/9/19	Wed 3/11/20																																										
37	Luminant Bid/Award East Ash Pond Retrofit Construction Contract	39 days	Wed 1/29/20	Mon 3/23/20																																										
38	Luminant Bid/Award West Ash Pond Retrofit Construction Contract	61 days	Fri 1/15/21	Fri 4/9/21																																										
39	Luminant Bid/Award New Scrubber Pond Retrofit Construction Contract	61 days	Fri 1/14/22	Fri 4/8/22																																										
40	East Ash Pond Retrofit Construction	351 days	Mon 6/3/19	Mon 10/5/20																																										
41	Luminant Removal of Poned CCR Material during Operations	90 days	Mon 6/3/19	Fri 10/4/19																																										
42	Dewatering of EAP to other CCR impoundments	15 days	Tue 6/9/20	Mon 6/29/20																																										

Project: Martin Lake CCR Surface Impoundment Extension Demonstration Date: Mon 9/28/20	Task		Project Summary		Inactive Milestone		Manual Summary Rollup		Deadline	
	Split		External Tasks		Inactive Summary		Manual Summary		Progress	
	Milestone		External Milestone		Manual Task		Start-only		Manual Progress	
	Summary		Inactive Task		Duration-only		Finish-only			

APPENDIX C – EAST ASH POND RETROFIT DESIGN DRAWINGS

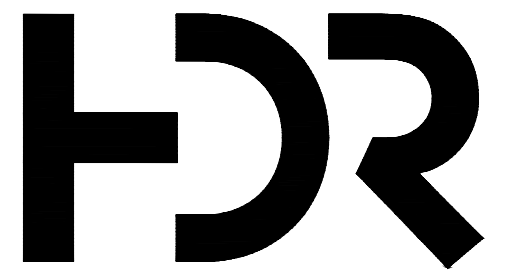

HDR
 Firm Registration No. F-754
 17111 Preston Road, Suite 300
 Dallas, Texas 75248-1229
 972.960.4400

Construction Drawings For

Martin Lake Steam Electric Station

CCR Impoundment Reline East Ash Pond

Project No.
 10172630

Rusk County, Texas
 January 2020

INDEX OF DRAWINGS

GENERAL	
00G-01	COVER SHEET
00G-02	ABBREVIATIONS AND GENERAL NOTES
CIVIL	
00C-01	SITE LAYOUT
00C-02	EAST ASH POND
00C-03	CROSS SECTIONS
00C-04	DETAILS (1 OF 2)
00C-05	DETAILS (2 OF 2)
00C-06	EXISTING YARD PIPING
00C-07	MODIFIED YARD PIPING
00C-08	YARD PIPING CONNECTIONS AND DETAILS
00C-09	YARD PIPING CONNECTIONS AND DETAILS
00C-10	YARD PIPING DETAILS
00C-11	STOCKPILE AND HAUL ROUTE



VICINITY MAP
 NOT TO SCALE

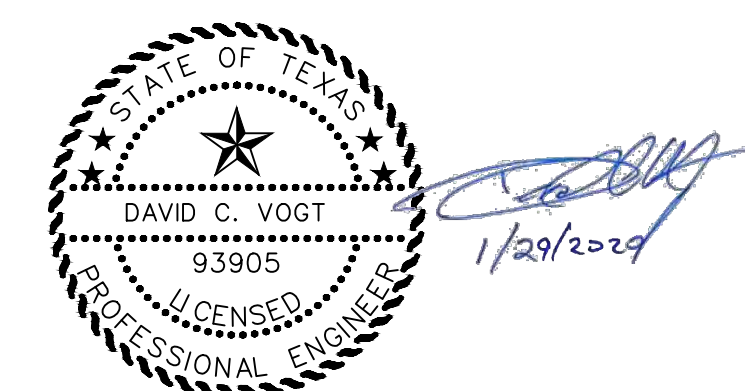

STANDARD ABBREVIATIONS

&	AND
APPROX	APPROXIMATELY
@	AT
AVG	AVERAGE
BOE	BOTTOM OF EXCAVATION
BOL	BOTTOM OF LINER
X	BY
CL	CENTERLINE
CMP	CORRUGATED METAL PIPE
CO	CLEAN OUT
CY	CUBIC YARD
DIA	DIAMETER
DET	DETAIL
DWG	DRAWING
E	EAST
EAP	EAST ASH POND
ELEV	ELEVATION
EW	EACH WAY
EXIST	EXISTING
EXC	EXCAVATION
FGD	FLUE GAS DESULFICATION
FML	FLEXIBLE MEMBRANE LINER
FT	FEET
GAL	GALLON
GND	GROUND
GDL	GRAVEL DRAINAGE LAYER
GNDL	GEONET DRAINAGE LAYER
HDPE	HIGH DENSITY POLYETHYLENE
HORIZ	HORIZONTAL
ID	INSIDE DIAMETER
IN	INCHES
IE	INVERT ELEVATION
LCRS	LEACHATE COLLECTION AND REMOVAL SYSTEM
LCS	LEACHATE COLLECTION SYSTEM
LCP	LEACHATE COLLECTION PIPE
LCPR	LEACHATE COLLECTION PIPE RISER
LF	LINEAR FEET
LB	POUND
MH	MANHOLE
MAX	MAXIMUM
MIL	.001 INCHES
MIN	MINIMUM
MW	MONITOR WELL
MLSES	MARTIN LAKE STEAM ELECTRIC STATION
MSL	MEAN SEA LEVEL
N	NORTH
NIC	NOT IN CONTRACT
NO	NUMBER

NTS	NOT TO SCALE
NTYS	NORTH THICKENER YARD SUMP
OC	ON CENTER
OZ	OUNCE
%	PERCENT
PLCP	PERFORATED LEACHATE COLLECTION PIPE
PERF	PERFORATED
PGL	PROFILE GRADE LINE
PDP	PERMANENT DISPOSAL POND
PC	POINT OF CURVATURE
PI	POINT OF INTERSECTION
PVI	POINT OF VERTICAL INTERSECTION
PT	POINT OF TANGENT
PZ	PIEZOMETER
Q	FLOW
QTY	QUANTITY
R	RADIUS
RCP	REINFORCED CONCRETE PIPE
REF	REFERENCE
REQ	REQUIRED
RD	ROAD
SCH	SCHEDULE
SDL	SAND DRAINAGE LAYER
SEC	SECTION
SHT	SHEET
S	SOUTH
SDR	STANDARD DIMENSION RATIO
SLQCP	SOIL LINER QUALITY CONTROL PLAN
SP	STEEL PIPE
SQ	SQUARE
SS	SIDE SLOPE
STA	STATION
STYS	SOUTH THICKENER YARD SUMP
T.A.S.	TERMINAL ANCHOR SECTION
TL	TANGENT LENGTH
TOC	TOP OF COVER
TOFC	TOP OF FINAL COVER
TOL	TOP OF LINER
TOS	TOE OF SLOPE
TS	TOP SLOPE
TEMP	TEMPORARY
TYP	TYPICAL
UNO	UNLESS NOTED OTHERWISE
VERT	VERTICAL
W	WEST
W/	WITH
WAP	WEST ASH POND
WW	WETWELL
YD	YARD

CONSTRUCTION SEQUENCE

- A. CONTRACTOR SHALL REMOVE EXISTING CCR MATERIAL, ROCKS AND SEDIMENT FROM THE EAP, HAUL AND STOCKPILE IT AT THE DECANT BASIN. LUMINANT WILL LOAD THE STOCKPILED MATERIAL ONTO RAIL CARS FOR DISPOSAL AT THE MARTIN LAKE A-1 AREA LANDFILL.
- B. CONTRACTOR SHALL USE WATER FROM THE ADJACENT WEST ASH POND (WAP) OR NEW SCRUBBER POND (SP) TO WASH REMAINING CCR MATERIAL OFF THE SIDES AND FLOOR OF THE EAP AND REMOVE IT. EAP WILL BE VISUALLY INSPECTED BY OWNER'S CQA CONSULTANT TO CONFIRM CCR MATERIAL, ROCKS, AND SEDIMENT HAVE BEEN REMOVED.
- C. CONTRACTOR SHALL MODIFY THE EXISTING 48-INCH SUCTION LINE ON THE SOUTH END OF THE POND BY INCREASING THE SCREENED AREA AS SHOWN IN THE PLANS.
- D. CONTRACTOR SHALL LOAD AND HAUL GENERAL SOIL FILL MATERIAL FROM THE OWNER'S STOCKPILE LOCATED AT LIBERTY MINE, A LOCATION UNDER THE PROVISIONS OF THE MINE SAFETY AND HEALTH ADMINISTRATION (MSHA) AND APPROXIMATELY 4.5 MILES FROM EAP.
- E. CONTRACTOR SHALL PLACE THE GENERAL FILL MATERIAL OVER THE EXISTING CONCRETE REVETMENT TO A DEPTH OF AT LEAST SIX (6) INCHES, NOMINALLY COMPACT, AND SMOOTH ROLL TO FINISH THE INSTALLATION.
- F. CONTRACTOR SHALL INSTALL A GEOSYNTHETIC CLAY LINER (GCL) OVER THE SIDES AND FLOOR OF THE EAP AND SECURE IT IN A PERIMETER ANCHOR TRENCH/BATTEN AND STRIP.
- G. CONTRACTOR SHALL INSTALL A 60-MIL HDPE LINER DIRECTLY ON THE GCL AND SECURE IT IN A PERIMETER ANCHOR TRENCH/BATTEN AND STRIP.
- H. CONTRACTOR SHALL INSTALL 12-INCH HDPE YARD PIPE AS SHOWN IN THE PLANS.

GENERAL NOTES

1. ALL WORK UNDER THIS CONTRACT SHALL BE PERFORMED IN ACCORDANCE WITH THE PLANS AND PROJECT SPECIFICATIONS. IN THE EVENT OF A DISCREPANCY BETWEEN THE PLANS AND THE PROJECT SPECIFICATIONS, THE SPECIFICATIONS SHALL GOVERN.
2. COORDINATE SYSTEM IS BASED ON LOCAL SURVEY. THE BENCHMARKS TO BE USED FOR CONSTRUCTION ARE LOCATED AS SHOWN ON DRAWING NO. 00G-01. EXISTING CONTOURS ARE BASED ON TOPOGRAPHICAL SURVEY PERFORMED FEBRUARY 12-20, 2019 BY LACY SURVEYING. CURRENT GROUND ELEVATIONS MAY VARY FROM THOSE SHOWN DUE TO SITE WORK THAT HAS BEEN PERFORMED SINCE THE SURVEY WAS PERFORMED.
3. THE CONTRACTOR SHALL VERIFY EXISTING CONTOURS PRIOR TO THE START OF WORK.
4. THERE SHALL NOT BE ANY ADDITIONAL PAYMENT OR EXTENSION OF CONTRACT TIME FOR WORKING WITH SATURATED SOILS OR HANDLING WATER SEEPAGE DUE TO RAINFALL, RUNOFF AND INFILTRATION.
5. THE CONTRACTOR SHALL TAKE ALL NECESSARY PRECAUTIONS TO PROTECT EXISTING ROADS, BENCHMARKS AND EXISTING GROUNDWATER MONITOR WELLS DURING THE CONSTRUCTION PERIOD. THE CONTRACTOR SHALL BE SOLELY RESPONSIBLE FOR ANY AND ALL DAMAGES WHICH MIGHT BE INCURRED BY THE CONTRACTOR'S FAILURE TO EXACTLY LOCATE AND PROTECT THE GROUNDWATER MONITOR WELLS, BENCHMARKS AND EXISTING ROADS.
6. THE LOCATIONS OF EXISTING UNDERGROUND UTILITIES HAVE NOT BEEN ESTABLISHED BY THE OWNER OR ENGINEER. THE CONTRACTOR SHALL DETERMINE THE EXACT LOCATION OF ALL EXISTING UTILITIES BEFORE COMMENCING WORK, AND AGREE TO BE FULLY RESPONSIBLE FOR ANY AND ALL DAMAGES WHICH MIGHT BE OCCASIONED BY THE CONTRACTOR'S FAILURE TO EXACTLY LOCATE AND PRESERVE ANY AND ALL UTILITIES. THE CONTRACTOR SHALL BE RESPONSIBLE FOR MAINTAINING PROPER SAFE WORKING DISTANCE FROM ALL UTILITY EASEMENTS OR LINES.
7. EXCAVATION BY "BLASTING" IS NOT PERMITTED ON THIS PROJECT.
8. FINISHED GROUND ELEVATIONS SHALL MATCH EXISTING GROUND ELEVATIONS EXCEPT AS SHOWN ON THE PLANS. ALL EXCESS SOIL FROM THE EXCAVATION AND GRADING SHALL BE PLACED IN DESIGNATED STOCKPILE LOCATIONS AS APPROVED BY THE OWNER. IF WASTE IS ENCOUNTERED DURING EXCAVATION, THE OWNER SHALL BE NOTIFIED AND THE WASTE REMOVED AND PLACED IN AREAS DESIGNATED AS APPROVED BY THE OWNER. TRANSPORT OF SOIL TO FILL AREAS SHALL BE CONDUCTED BY THE CONTRACTOR AT NO ADDITIONAL EXPENSE TO THE OWNER.
9. GEOTECHNICAL INVESTIGATION REPORTS FOR THE SITE ARE AVAILABLE FOR REVIEW AT LUMINANT'S DALLAS OFFICES. THE CONTRACTOR MAY PERFORM ADDITIONAL GEOTECHNICAL INVESTIGATIONS, AS DEEMED NECESSARY FOR CONSTRUCTION ACTIVITIES, PROVIDED ALL NECESSARY PERMITS AND APPROVALS ARE OBTAINED FROM LUMINANT PRIOR TO INITIATING SUCH WORK. HOWEVER, THERE SHALL BE NO ADDITIONAL PAYMENT TO THE CONTRACTOR FOR ADDITIONAL GEOTECHNICAL INVESTIGATIONS.
10. THE CONTRACTOR SHALL CONSTRUCT, AND UPON COMPLETION OF THE PROJECT, REMOVE TEMPORARY CONSTRUCTION ACCESS ROADS. SUCH ROADS SHALL BE LOCATED AS APPROVED BY THE OWNER. DRAINAGE PATTERNS AT THE SITE SHALL NOT BE ALTERED BY ROAD CONSTRUCTION. THE CONTRACTOR SHALL BE RESPONSIBLE FOR CONSTRUCTION AND MAINTENANCE OF TEMPORARY DRAINAGE STRUCTURES, INCLUDING CULVERTS, AT NO ADDITIONAL COST TO THE OWNER.
11. THE CONTRACTOR SHALL INSTALL, MAINTAIN, AND UPON COMPLETION OF THE PROJECT, REMOVE TEMPORARY EROSION AND SEDIMENT CONTROLS AS APPROVED BY LUMINANT ENVIRONMENTAL SERVICES AND IN ACCORDANCE WITH THE SITE SWPPP AND PURSUANT TO TPDES REQUIREMENTS. SUCH CONTROLS SHALL BE PLACED AT THE LIMITS OF DISTURBED AREAS AND AT INTERMEDIATE LOCATIONS WHERE CONCENTRATED FLOW IS LIKELY.
12. TEMPORARY CONSTRUCTION SLOPES SHALL NOT BE GREATER THAN 2H:1V. STEEPER SLOPES WILL ONLY BE ALLOWED IF THE CONTRACTOR PROVIDES A GEOTECHNICAL ENGINEERING REPORT SPECIFYING MAXIMUM SLOPES AND THE DURATION FOR WHICH SUCH SLOPES SHALL REMAIN IN PLACE.
13. THE CONTRACTOR SHALL REMOVE ALL VEGETATION WITHIN THE CONSTRUCTION LIMITS AS REQUIRED TO CONSTRUCT THE PROJECT. ALL VEGETATION SHALL BE REMOVED BY CONTRACTOR AT NO ADDITIONAL EXPENSE TO OWNER.
14. THE CONTRACTOR SHALL OBTAIN AND CONDUCT WORK CONSISTENT WITH A TPDES PERMIT FOR CONSTRUCTION, REFER TO TECHNICAL SPECIFICATIONS. PREPARATION OF A SWPPP AND OBTAINING THE TPDES PERMIT ARE THE CONTRACTOR'S RESPONSIBILITY.
15. THE CONTRACTOR SHALL IMMEDIATELY REPORT TO THE ENGINEER ANY ERROR OR DISCREPANCY FOUND ONCE THE CONTRACT DOCUMENT IS CAREFULLY REVIEWED AND ALL ASPECTS OF FIELD WORK HAVE BEEN VERIFIED. IN THE EVENT THE CONTRACTOR CONTINUES TO WORK ON AN ITEM WHERE AN ERROR EXISTS, IT SHALL BE DEEMED THAT THE CONTRACTOR BID AND INTENDED TO EXECUTE THE MORE STRINGENT OR HIGHER QUALITY REQUIREMENT WITHOUT AN INCREASE IN CONTRACT SUM OR TIME. THE CONTRACTOR SHALL ALSO BE RESPONSIBLE TO CORRECT ANY FAILURE OF COMPANY PARTS TO COORDINATE OR FIT PROPERLY INTO FINAL POSITION, AS A RESULT OF CONTRACTOR FAILURE TO RAISE OR RESOLVE A DISCREPANCY.
16. THE DRAWINGS AND SPECIFICATIONS SHOULD AGREE WITH EACH OTHER, AND WORK CALLED FOR BY DRAWINGS AND NOT MENTIONED IN SPECIFICATION, OR VICE VERSA, SHALL BE FURNISHED BY BOTH. WHEN DISCREPANCIES EXIST BETWEEN SCALE AND DIMENSIONS, THE DIMENSIONED FIGURE SHALL BE USED.
17. CONTRACTOR AND EACH SUBCONTRACTOR SHALL VERIFY ALL GRADES, LINES, LEVELS, AND DIMENSIONS AS INDICATED ON DRAWINGS, AND HE SHALL REPORT ERRORS TO THE ENGINEER BEFORE COMMENCING WORK. THE CONTRACTOR SHALL ESTABLISH BENCHMARKS IN AT LEAST TWO WIDELY SEPARATED PLACES, AND AS WORK PROGRESSES THE CONTRACTOR WILL MAINTAIN ADEQUATE HORIZONTAL AND VERTICAL CONTROL.
18. CONTRACTOR SHALL PROVIDE EROSION CONTROL BY SEEDING FOR ALL AREAS DISTURBED BY CONTRACTOR DURING THE CONSTRUCTION OF THIS PROJECT. THE CONTRACTOR SHALL NOT DISTURB ANY AREA WITHOUT THE APPROVAL OF THE ENGINEER. EROSION CONTROL BY SEEDING SHALL CONFORM TO STANDARD SPECIFICATION 02930.
19. CONTRACTOR SHALL INSTALL EROSION AND SEDIMENT CONTROLS AS PER SPECIFICATIONS DURING CONSTRUCTION. SUCH CONTROLS SHALL BE PLACED AT LIMITS OF DISTURBED AREAS AND AT INTERMEDIATE LOCATIONS WHERE CONCENTRATED FLOW IS LIKELY.
20. STORMWATER THAT HAS COME INTO CONTACT WITH THE ASH WITHIN THE EXCAVATED POND IS TO BE CONSIDERED CONTACT STORMWATER. CONTRACTOR WILL CONTROL THE WATER ON SITE IN COMPLIANCE WITH THE TPDES PERMIT.
21. THE CONTRACTOR IS REQUIRED TO PRESENT THE SWPPP TO LUMINANT ENVIRONMENTAL SERVICES FOR APPROVAL PRIOR TO THE COMMENCEMENT OF CONSTRUCTION ACTIVITIES.
22. THE CONTRACTOR IS REQUIRED TO SUBMIT THE NOTICE OF INTENT AND NOTICE OF TERMINATION FOR THE TPDES PERMIT.
23. THE CONTRACTOR IS TO ACQUIRE A DIGGING PERMIT FROM THE PLANT BEFORE COMMENCING ANY EXCAVATION ACTIVITY.

SYMBOLS

SECTION DETAIL INDICATORS

DRAWING ON WHICH SECTION IS CUT:

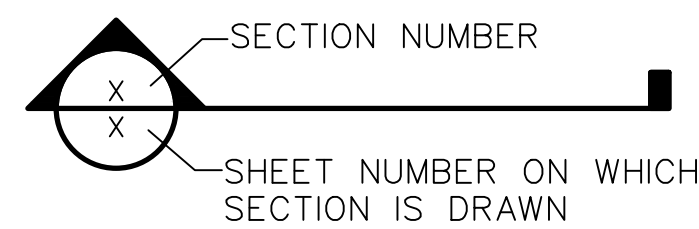

DRAWING ON WHICH SECTION APPEARS:

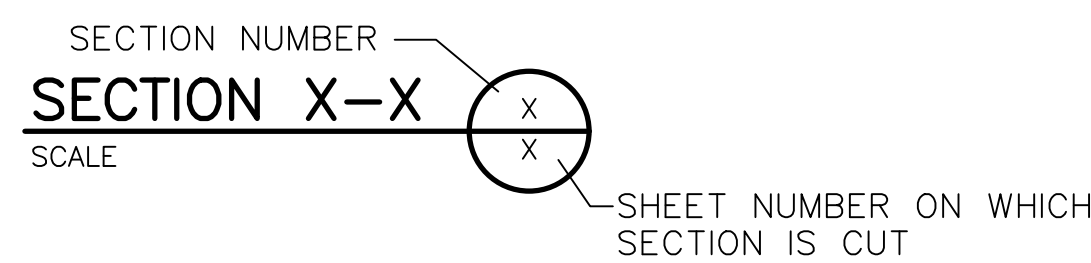

DRAWING ON WHICH DETAIL IS INDICATED:

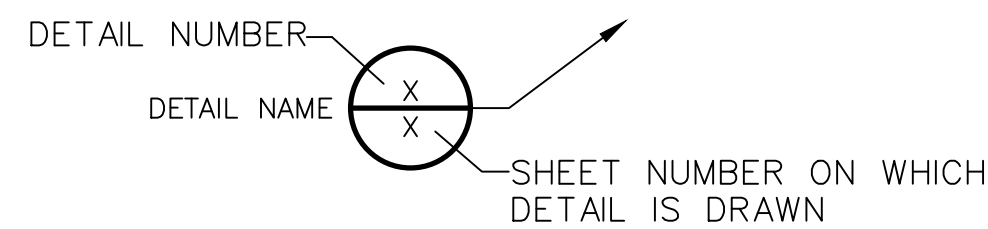

DRAWING ON WHICH DETAIL APPEARS:

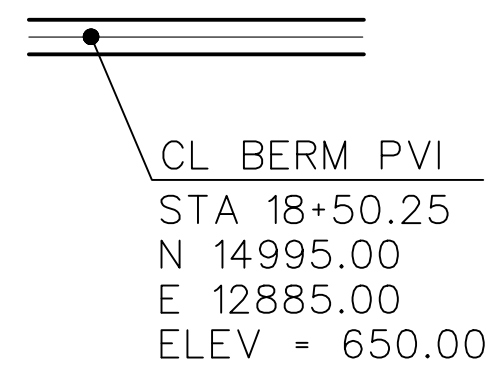
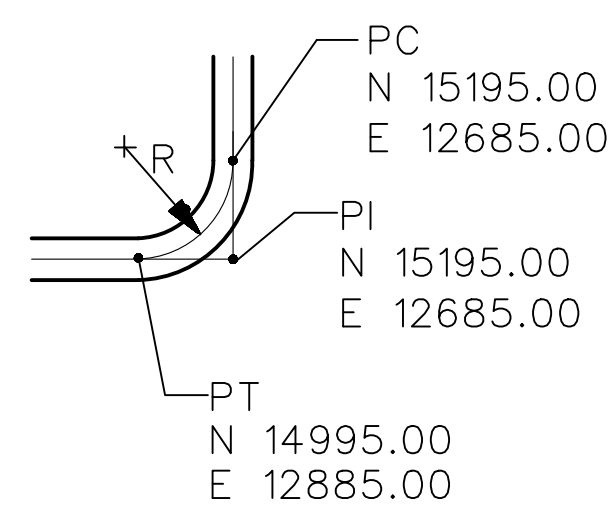
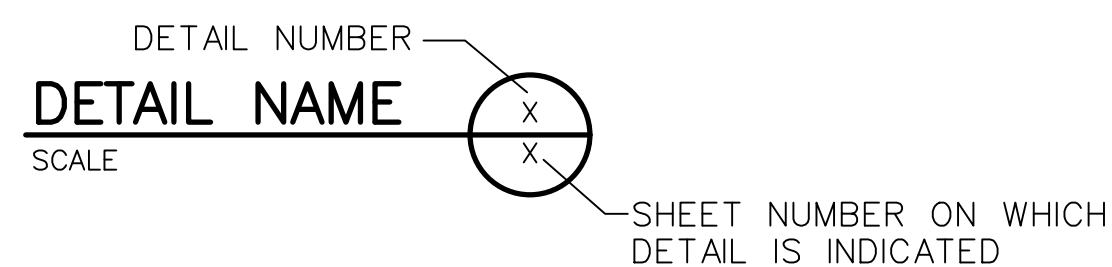

CURVE WITH HORIZONTAL CONTROL:

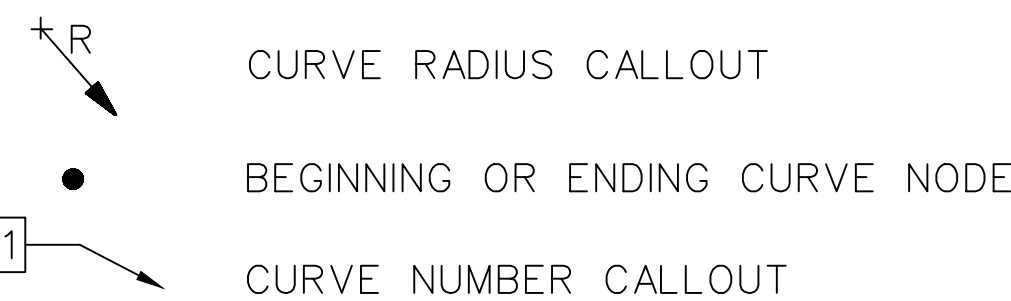

VERTICAL CONTROL DESIGNATION

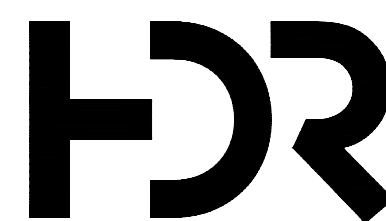
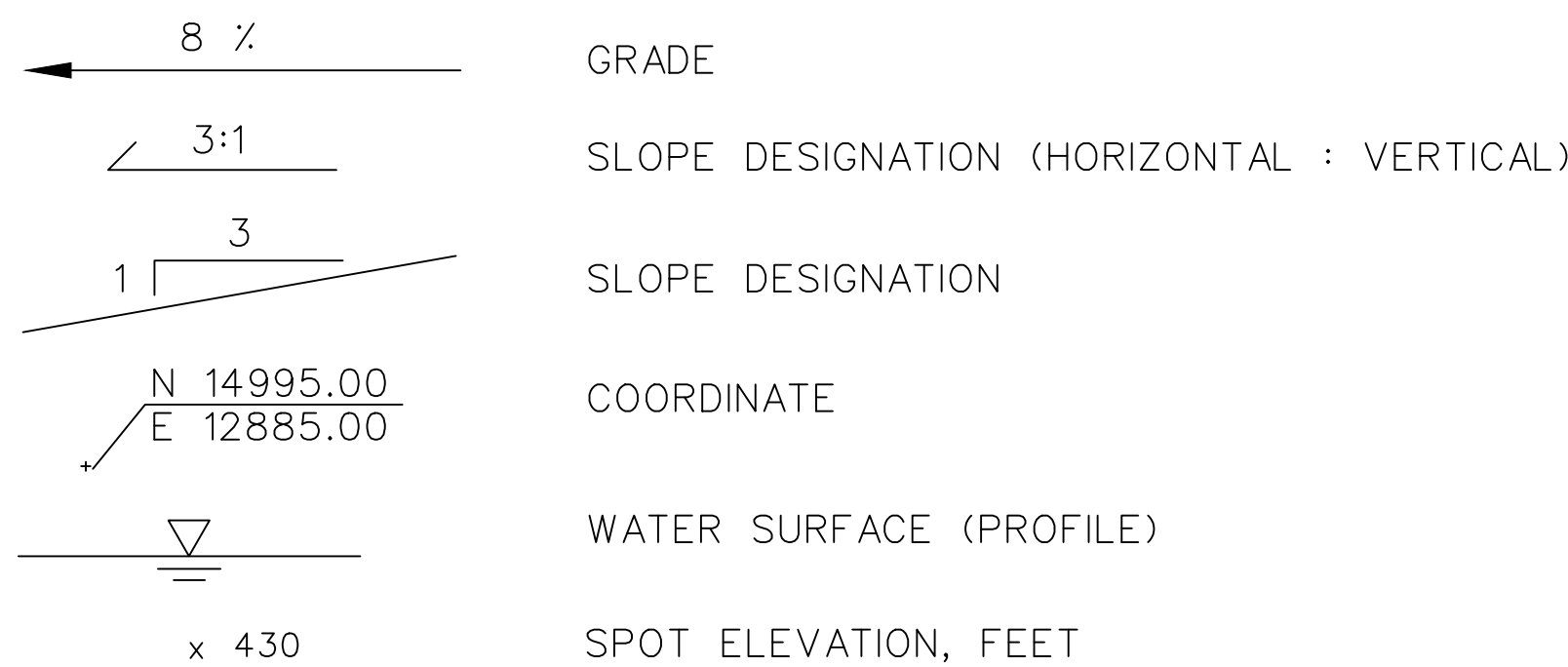

ISSUE	DATE	DESCRIPTION
F	01/29/2020	ISSUED FOR BID
E	01/23/2020	ISSUED FOR CLIENT REVIEW
D	01/14/2020	ISSUED FOR CLIENT REVIEW
C	12/20/2019	ISSUED FOR CLIENT REVIEW
B	11/28/2019	ISSUED FOR CLIENT REVIEW
A	11/12/2019	ISSUED FOR CLIENT REVIEW

PROJECT MANAGER	D. VOGT, P.E.
DESIGNED BY	K. PERERA
DRAWN BY	J. RAYMOND
CHECKED BY	M. ROBERTS
PROJECT NUMBER	10172630

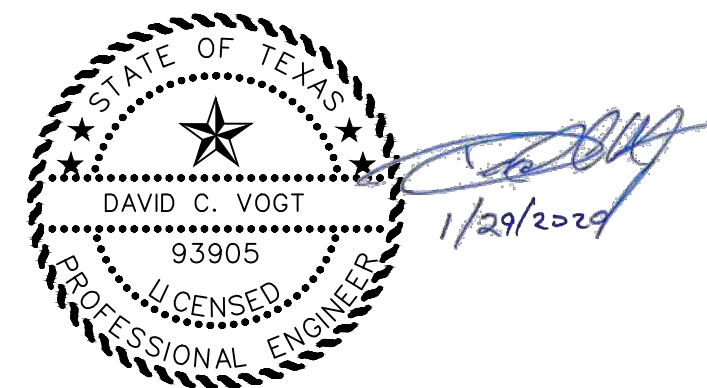

MARTIN LAKE STEAM ELECTRICAL STATION
EAST ASH POND RELINE
RUSK COUNTY, TEXAS



ABBREVIATIONS AND GENERAL NOTES



FILENAME | 00G-02.dwg
SCALE

SHEET
00G-02

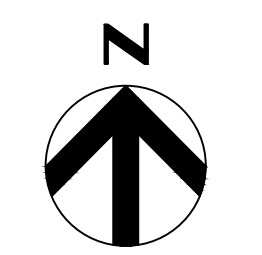

LEGEND
 ——— LIMITS OF CONSTRUCTION
 - - - - - LIMITS OF PDP 5

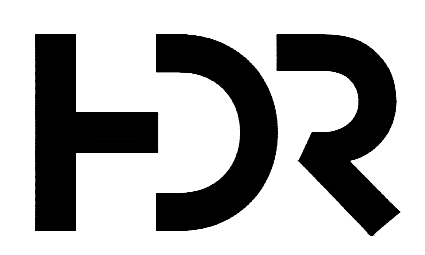
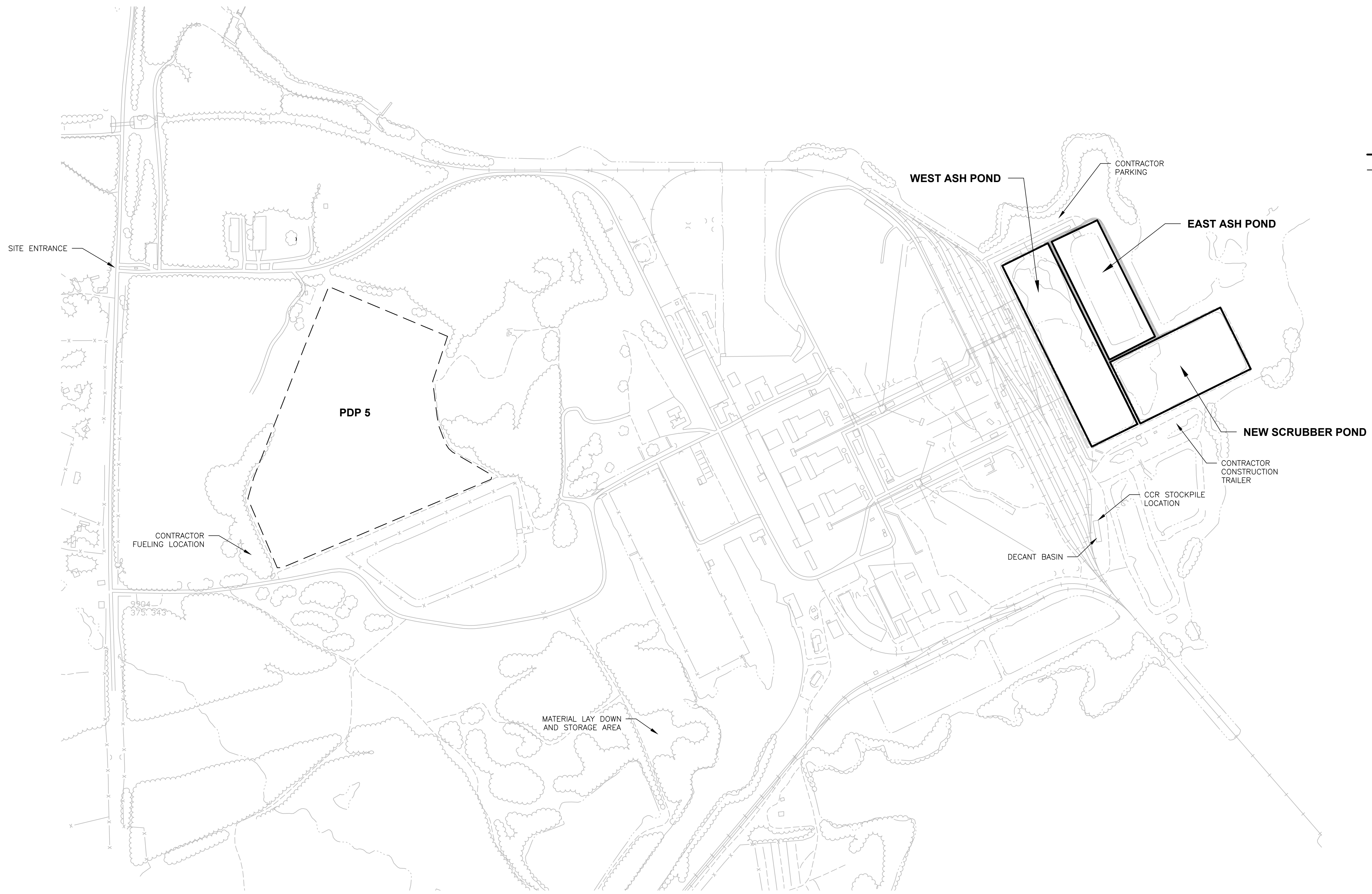

ISSUE	DATE	DESCRIPTION
F	01/29/2020	ISSUED FOR BID
E	01/23/2020	ISSUED FOR CLIENT REVIEW
D	01/14/2020	ISSUED FOR CLIENT REVIEW
C	12/20/2019	ISSUED FOR CLIENT REVIEW
B	11/26/2019	ISSUED FOR CLIENT REVIEW
A	11/12/2019	ISSUED FOR CLIENT REVIEW

PROJECT MANAGER	D. VOGT, P.E.
DESIGNED BY	K. PERERA
DRAWN BY	J. RAYMOND
CHECKED BY	M. ROBERTS
PROJECT NUMBER	10172630

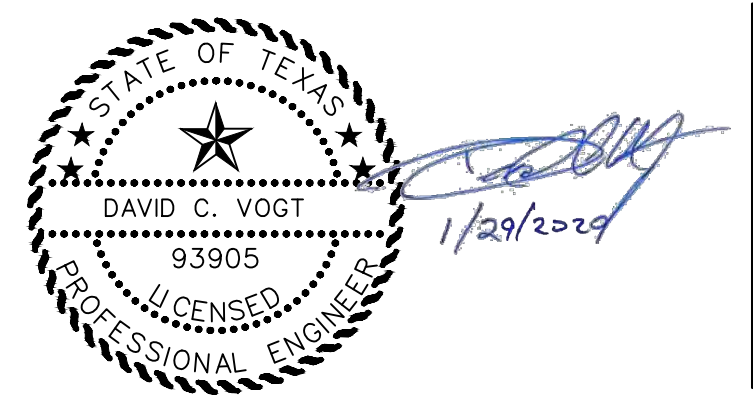

**MARTIN LAKE STEAM ELECTRICAL STATION
 EAST ASH POND RELINE
 RUSK COUNTY, TEXAS**

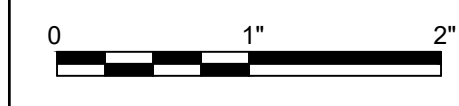

SITE LAYOUT

FILENAME | 00C-01.dwg
 SCALE | 1" = 400'

SHEET
00C-01

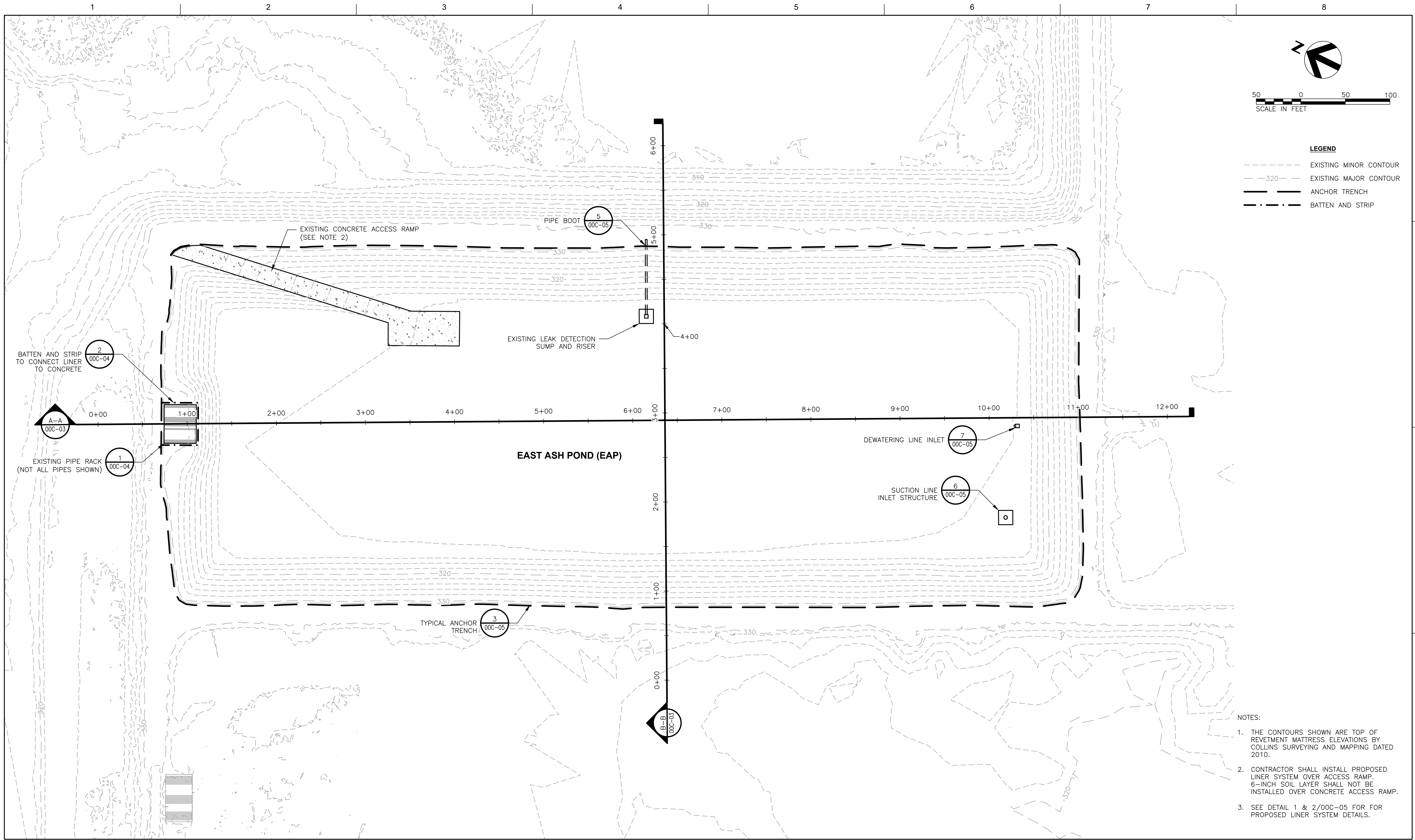

- LEGEND**
- - - - - EXISTING MINOR CONTOUR
 - - - - - 320 - - - - - EXISTING MAJOR CONTOUR
 - — — — — ANCHOR TRENCH
 - · - · - · - BATTEN AND STRIP

- NOTES:**
1. THE CONTOURS SHOWN ARE TOP OF REVETMENT MATTRESS ELEVATIONS BY COLLINS SURVEYING AND MAPPING DATED 2010.
 2. CONTRACTOR SHALL INSTALL PROPOSED LINER SYSTEM OVER ACCESS RAMP. 6-INCH SOIL LAYER SHALL NOT BE INSTALLED OVER CONCRETE ACCESS RAMP.
 3. SEE DETAIL 1 & 2/00C-05 FOR PROPOSED LINER SYSTEM DETAILS.

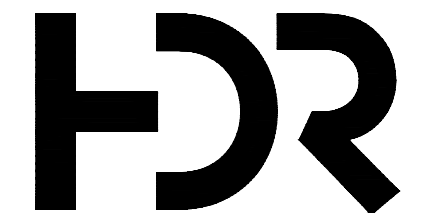

ISSUE	DATE	DESCRIPTION
F	01/29/2020	ISSUED FOR BID
E	01/23/2020	ISSUED FOR CLIENT REVIEW
D	01/14/2020	ISSUED FOR CLIENT REVIEW
C	12/20/2019	ISSUED FOR CLIENT REVIEW
B	11/26/2019	ISSUED FOR CLIENT REVIEW
A	11/12/2019	ISSUED FOR CLIENT REVIEW

PROJECT MANAGER	D. VOGT, P.E.
DESIGNED BY	K. PERERA
DRAWN BY	J. RAYMOND
CHECKED BY	M. ROBERTS
PROJECT NUMBER	10172630

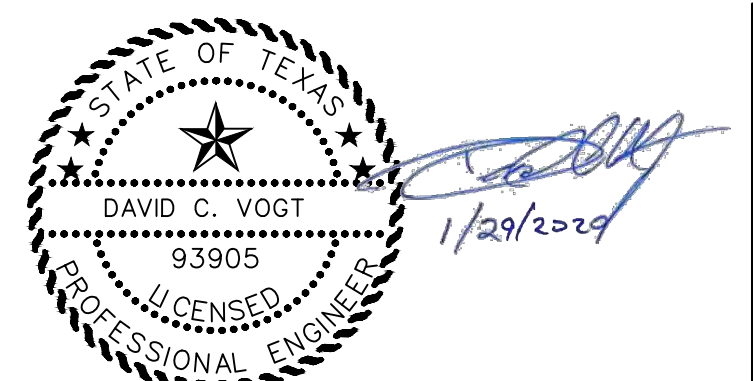

**MARTIN LAKE STEAM ELECTRICAL STATION
EAST ASH POND RELINE
RUSK COUNTY, TEXAS**



EAST ASH POND

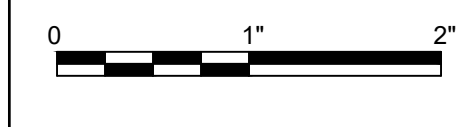

FILENAME | 00C-02.dwg
SCALE | 1" = 50'

SHEET
00C-02

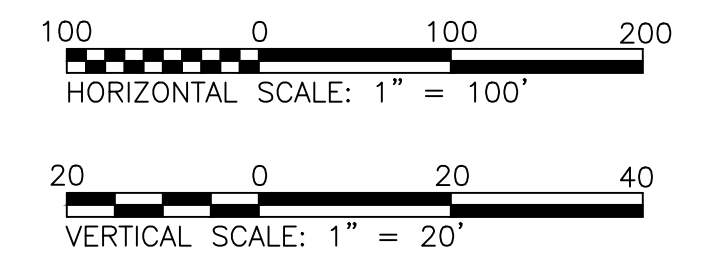

LEGEND
 - - - - - EXISTING GROUND SURFACE
 _____ PROPOSED GRADE

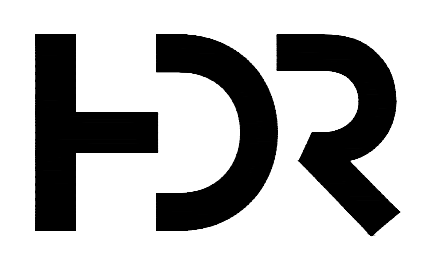
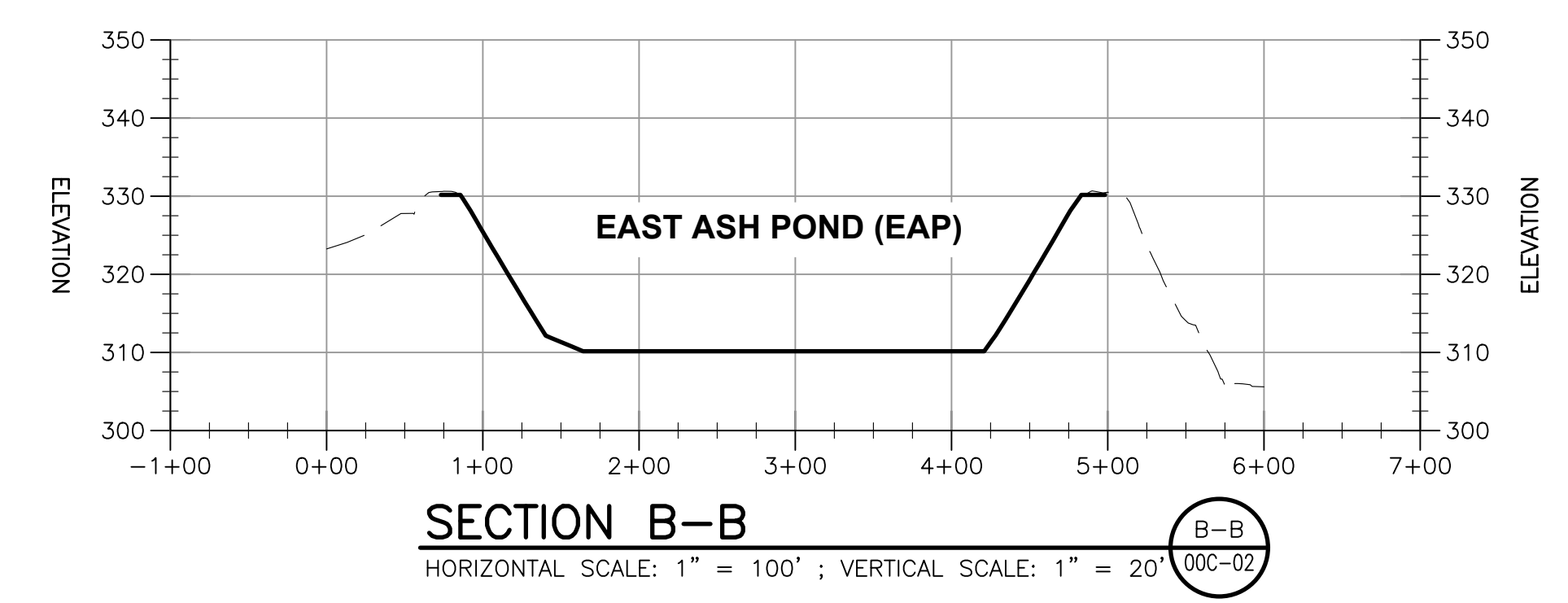
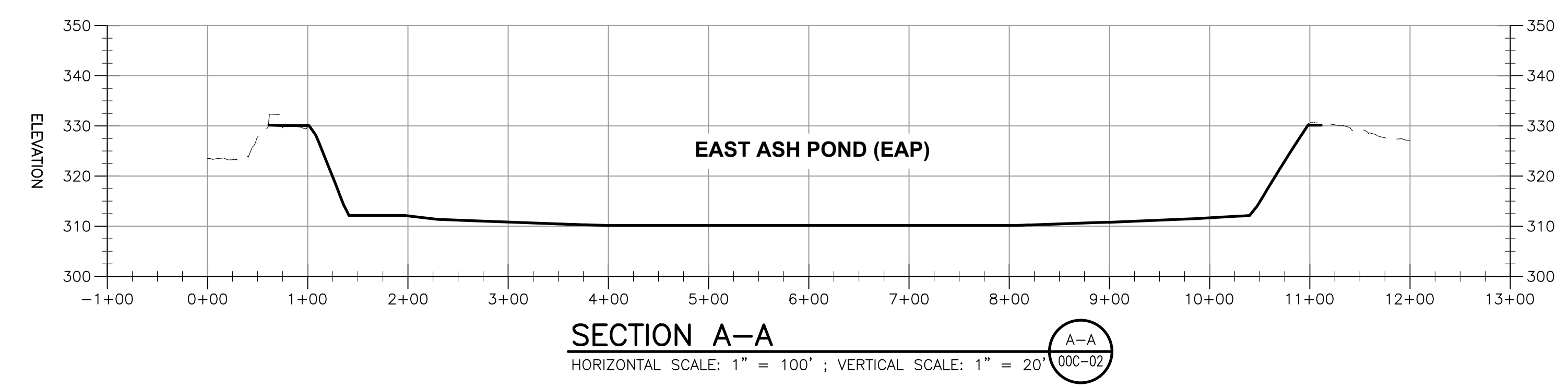

ISSUE	DATE	DESCRIPTION
F	01/29/2020	ISSUED FOR BID
E	01/23/2020	ISSUED FOR CLIENT REVIEW
D	01/14/2020	ISSUED FOR CLIENT REVIEW
C	12/20/2019	ISSUED FOR CLIENT REVIEW
B	11/26/2019	ISSUED FOR CLIENT REVIEW
A	11/12/2019	ISSUED FOR CLIENT REVIEW

PROJECT MANAGER	D. VOGT, P.E.
DESIGNED BY	K. PERERA
DRAWN BY	J. RAYMOND
CHECKED BY	M. ROBERTS
PROJECT NUMBER	10172630

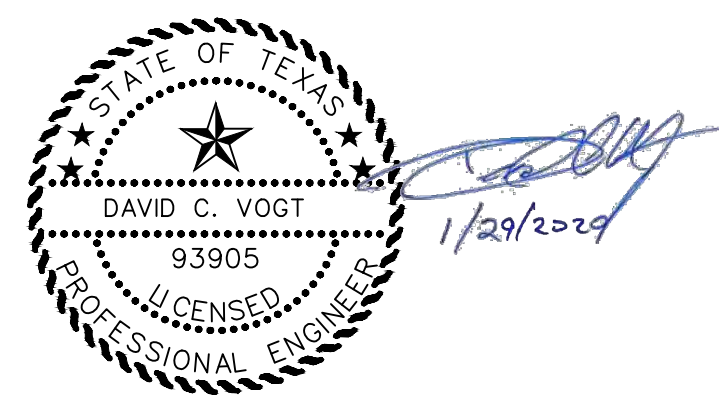

**MARTIN LAKE STEAM ELECTRICAL STATION
 EAST ASH POND RELINE
 RUSK COUNTY, TEXAS**



CROSS SECTIONS



FILENAME: 00C-03.dwg
 SCALE: H: 1" = 100' ; V: 1" = 20'

SHEET
00C-03

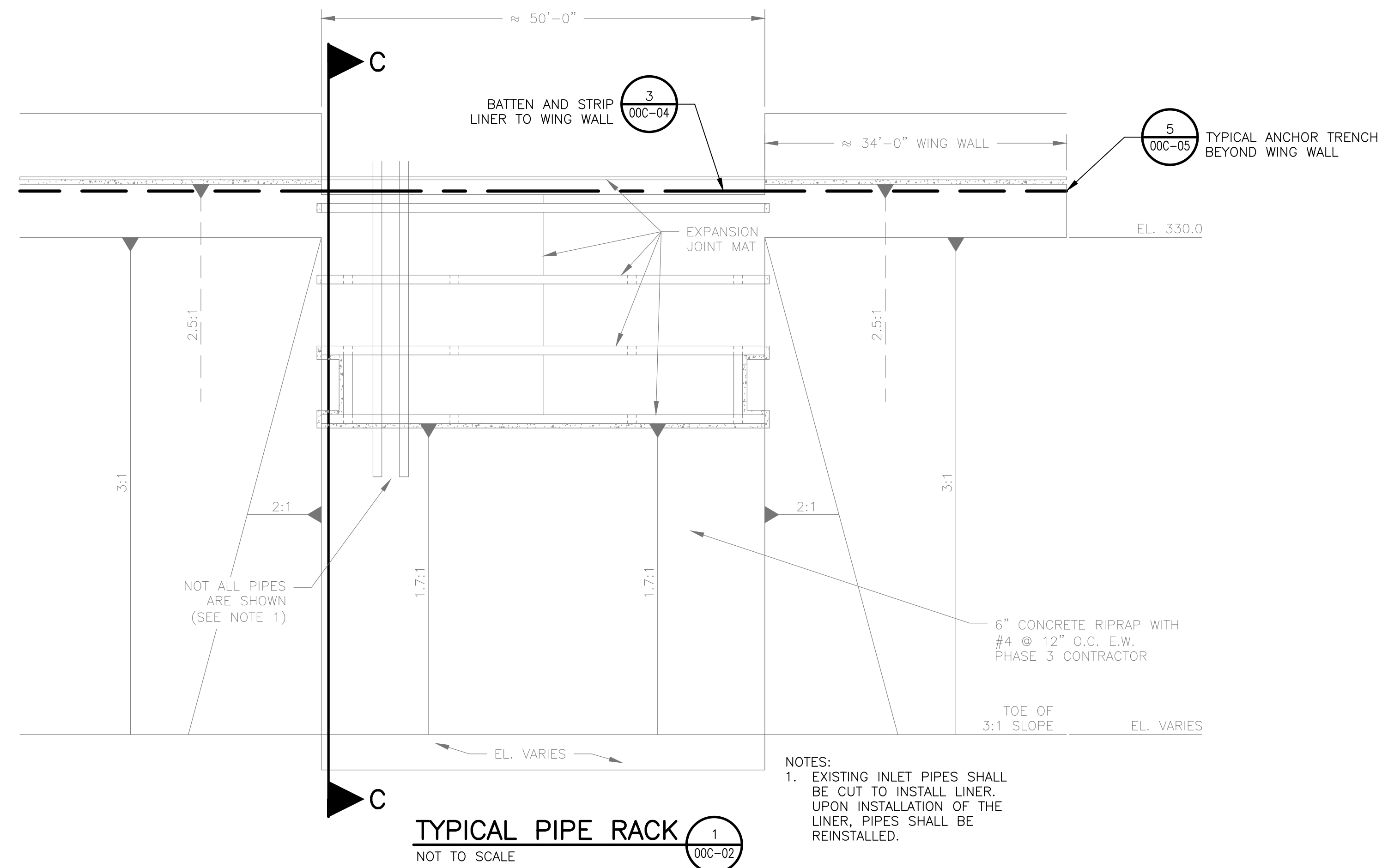

TYPICAL PIPE RACK
NOT TO SCALE

NOTES:
1. EXISTING INLET PIPES SHALL BE CUT TO INSTALL LINER. UPON INSTALLATION OF THE LINER, PIPES SHALL BE REINSTALLED.

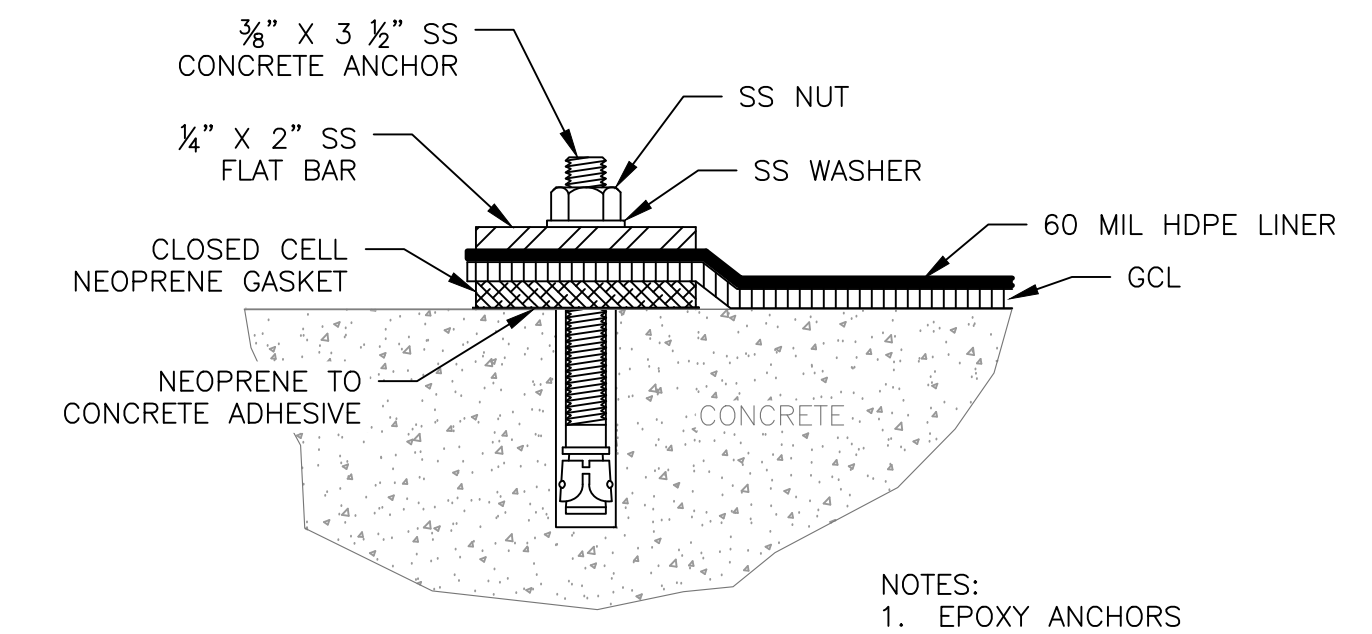

BATTEN AND STRIP CONNECTION AT ANCHOR TRENCH
NOT TO SCALE

NOTES:
1. EPOXY ANCHORS SPACED AT 6\"/>

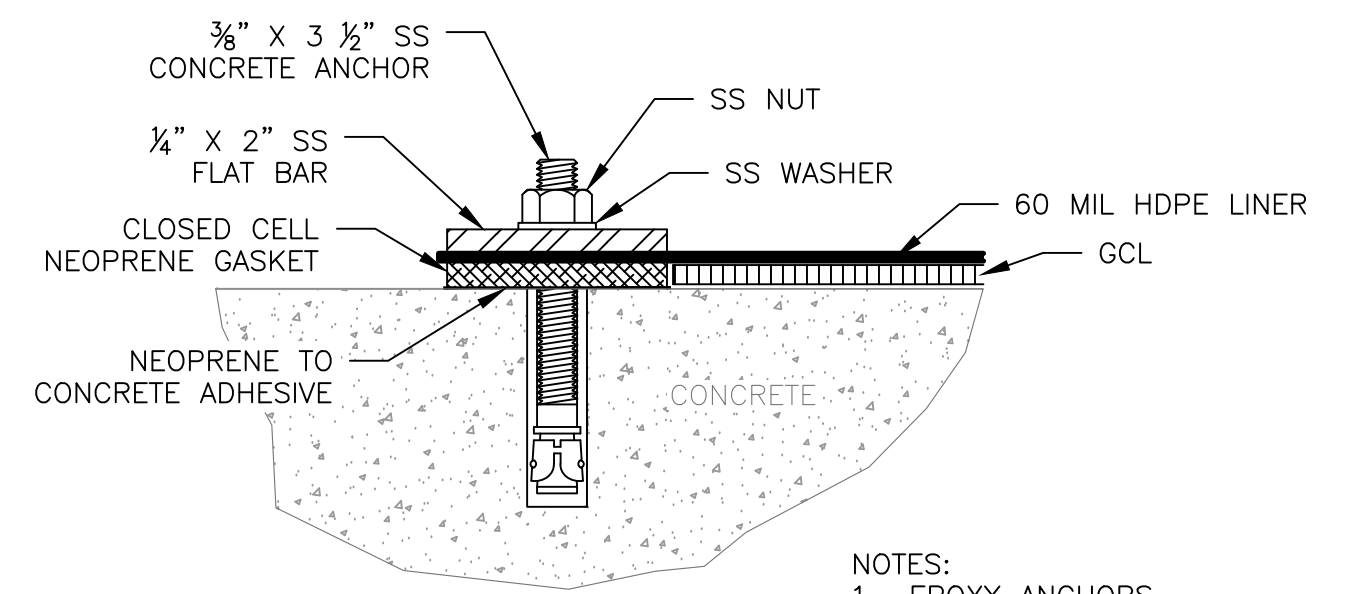

BATTEN AND STRIP CONNECTION BELOW WATER SURFACE
NOT TO SCALE

NOTES:
1. EPOXY ANCHORS SPACED AT 6\"/>

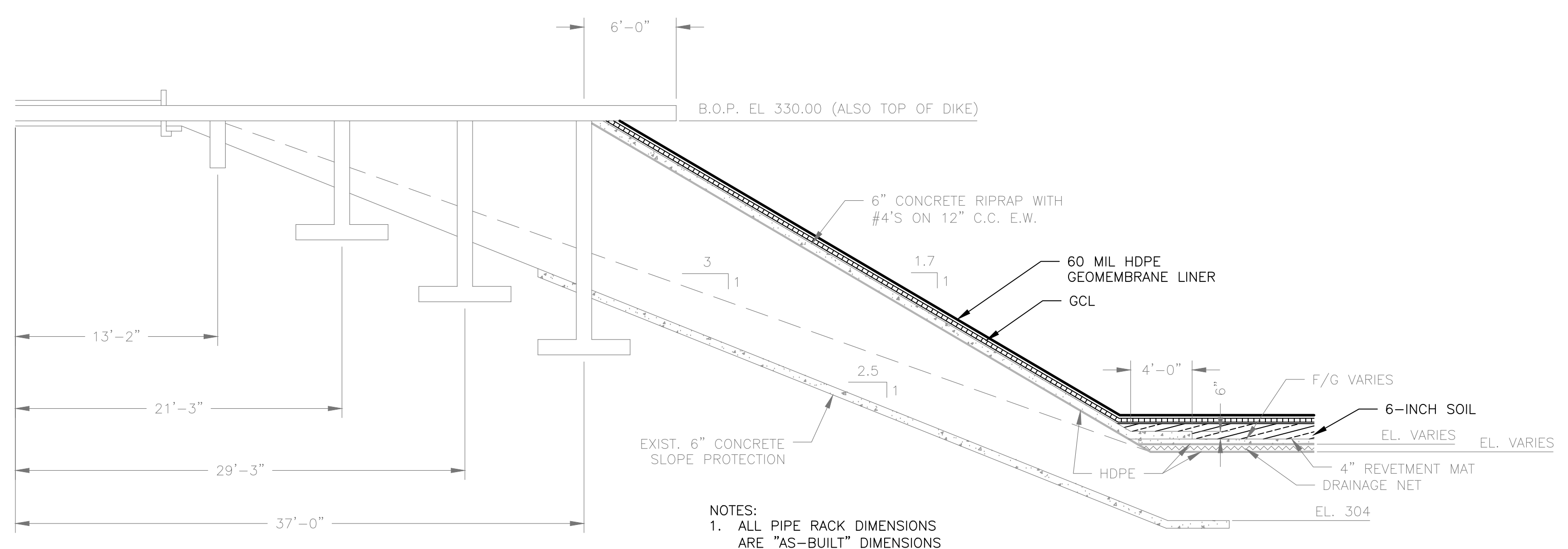

SECTION C-C
NOT TO SCALE

NOTES:
1. ALL PIPE RACK DIMENSIONS ARE \"AS-BUILT\" DIMENSIONS FOR EAST ASH POND.

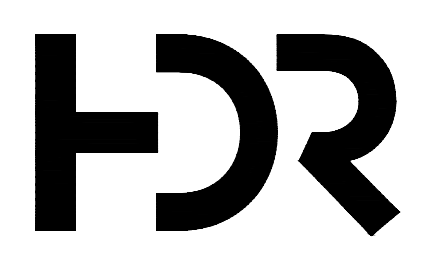

ISSUE	DATE	DESCRIPTION
F	01/29/2020	ISSUED FOR BID
E	01/23/2020	ISSUED FOR CLIENT REVIEW
D	01/14/2020	ISSUED FOR CLIENT REVIEW
C	12/20/2019	ISSUED FOR CLIENT REVIEW
B	11/28/2019	ISSUED FOR CLIENT REVIEW
A	11/12/2019	ISSUED FOR CLIENT REVIEW

PROJECT MANAGER	D. VOGT, P.E.
DESIGNED BY	K. PERERA
DRAWN BY	J. RAYMOND
CHECKED BY	M. ROBERTS
PROJECT NUMBER	10172630

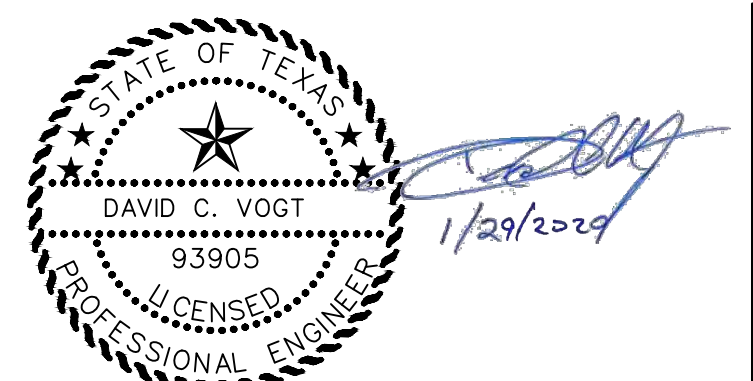

**MARTIN LAKE STEAM ELECTRICAL STATION
EAST ASH POND RELINE
RUSK COUNTY, TEXAS**



**DETAILS
(1 OF 2)**



FILENAME | 00C-04.dwg
SCALE |

SHEET
00C-04

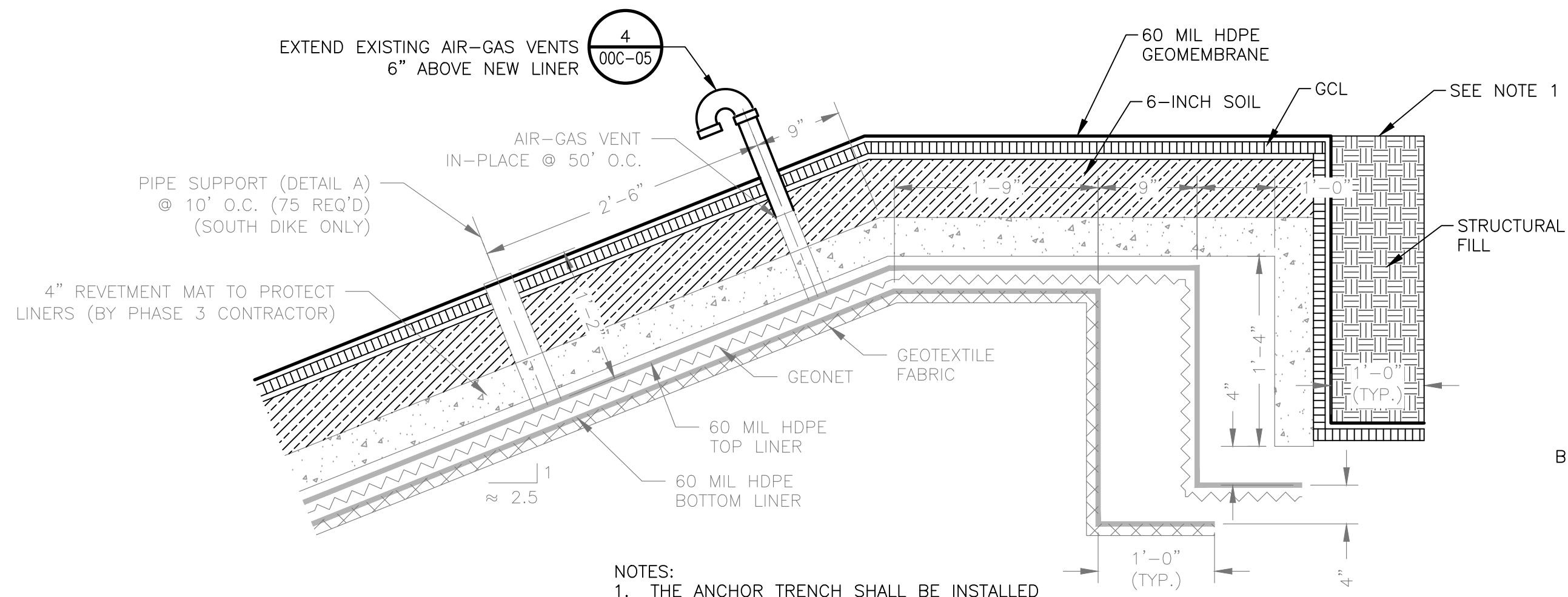

ANCHOR TRENCH
NOT TO SCALE

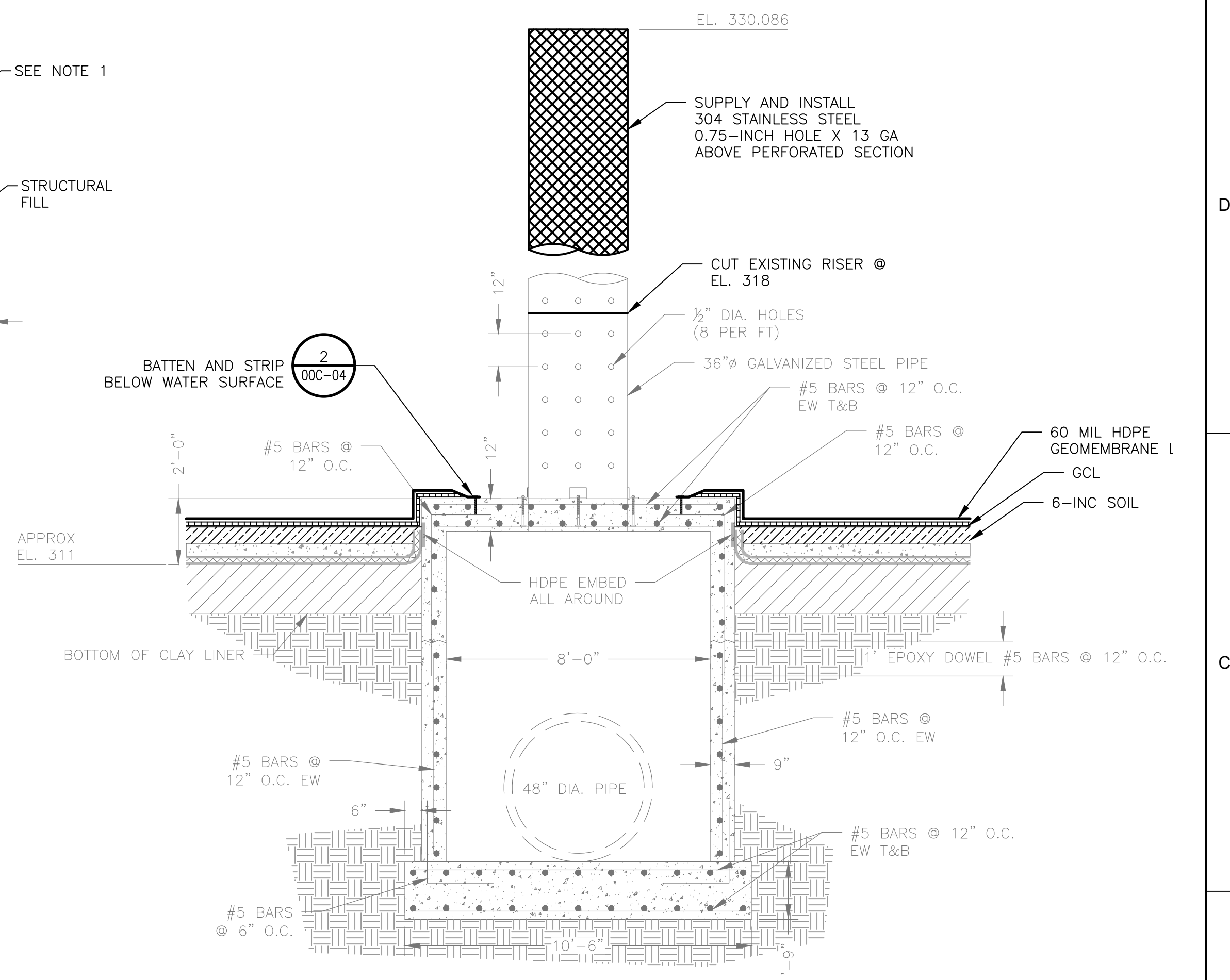

SUCTION LINE INLET STRUCTURE
NOT TO SCALE

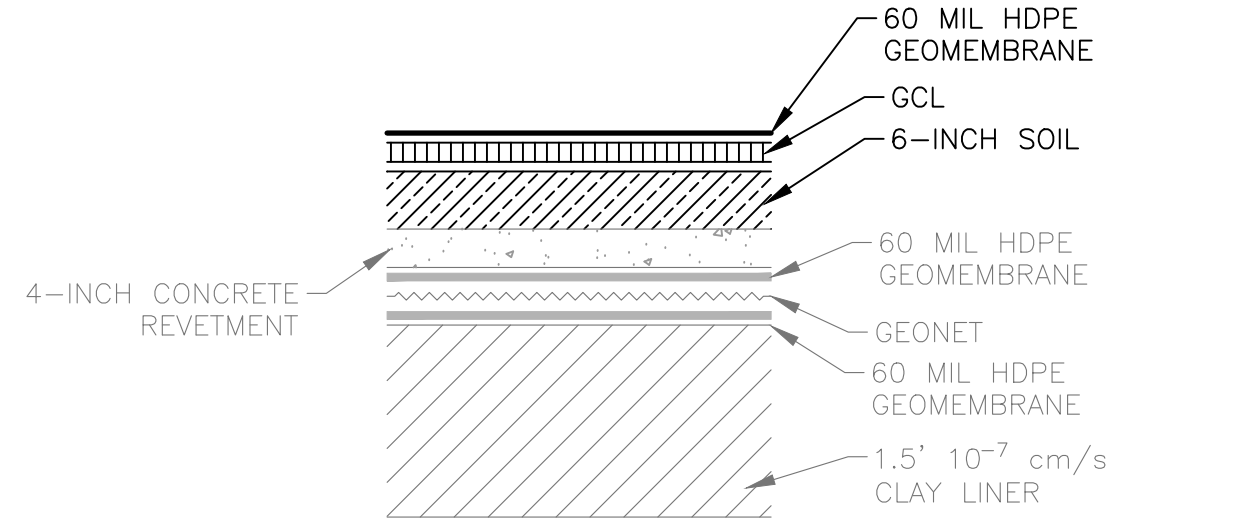

PROPOSED EAP RETROFIT SECTION (FLOOR)
NOT TO SCALE

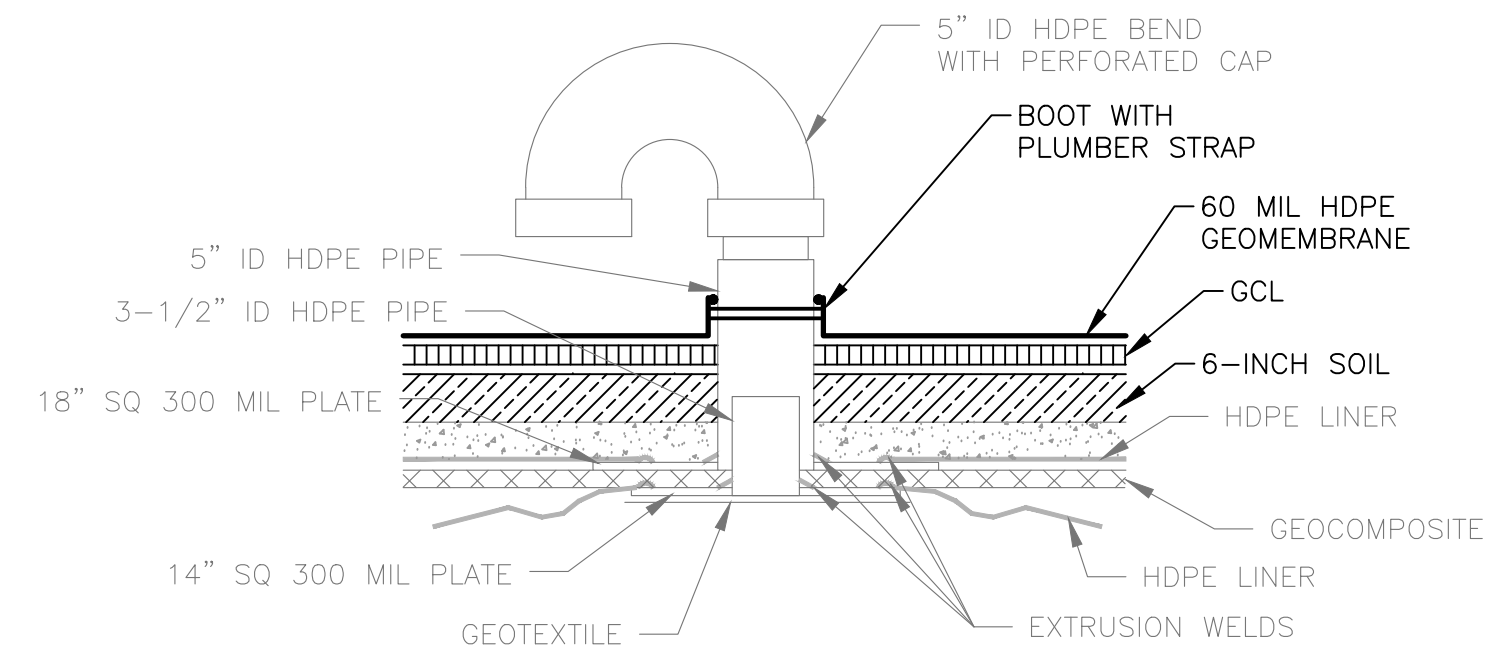

TYPICAL AIR-GAS VENT
NOT TO SCALE

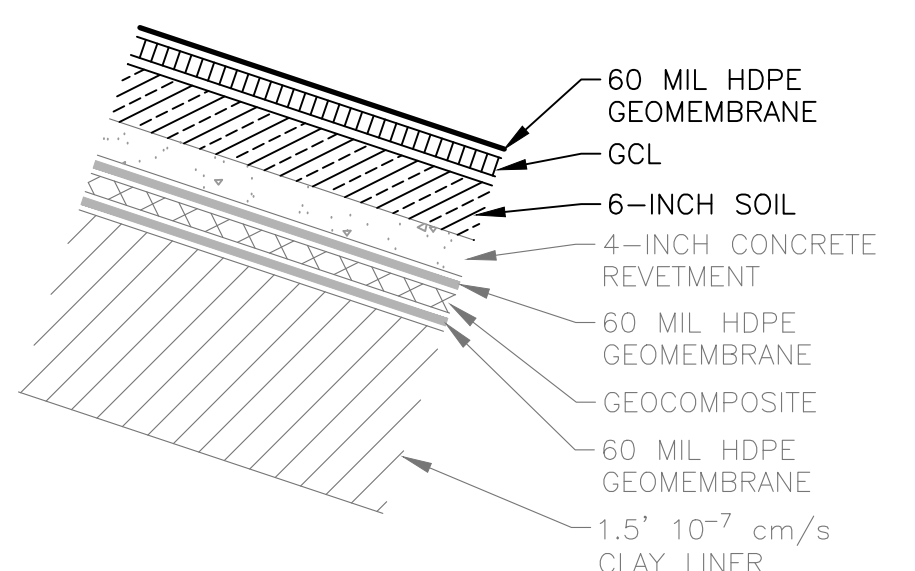

PROPOSED EAP RETROFIT SECTION (SIDESLOPE)
NOT TO SCALE

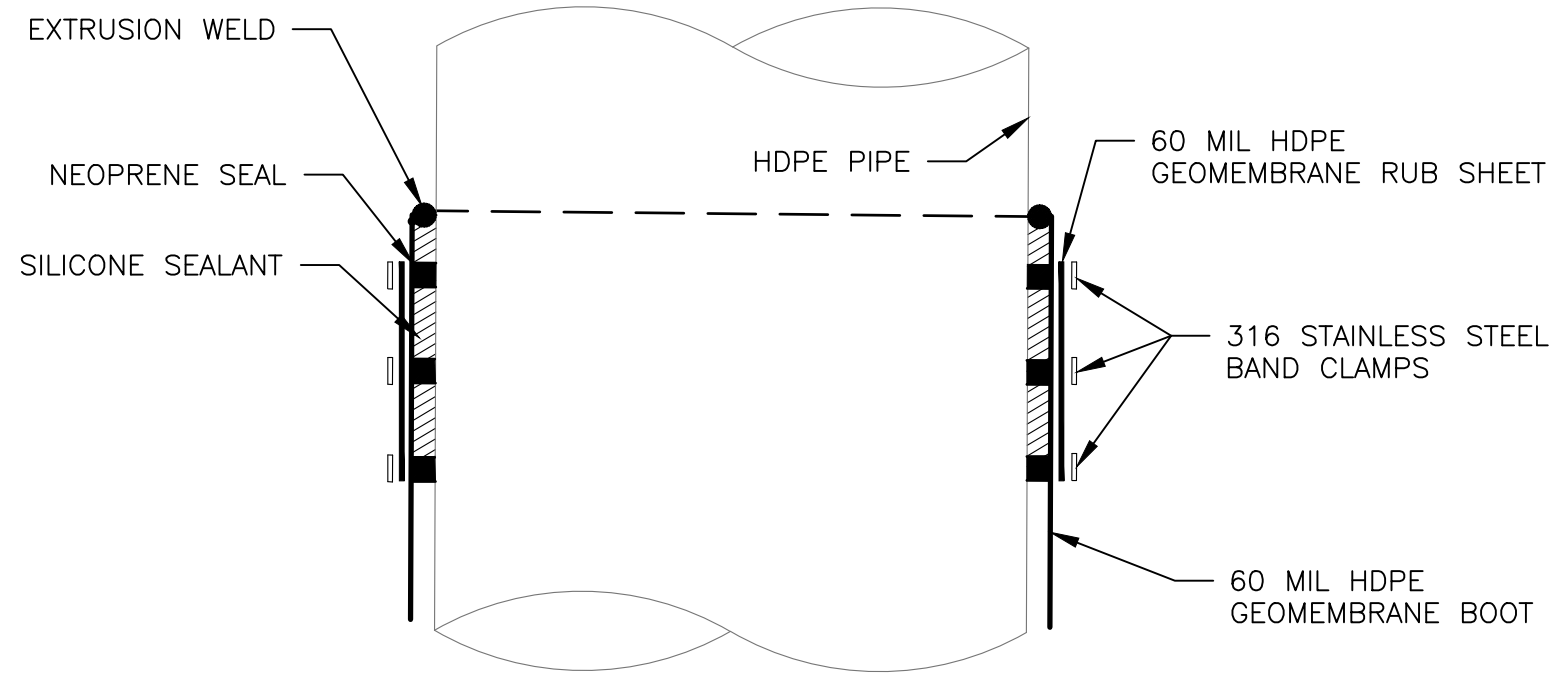

PIPE BOOT
NOT TO SCALE

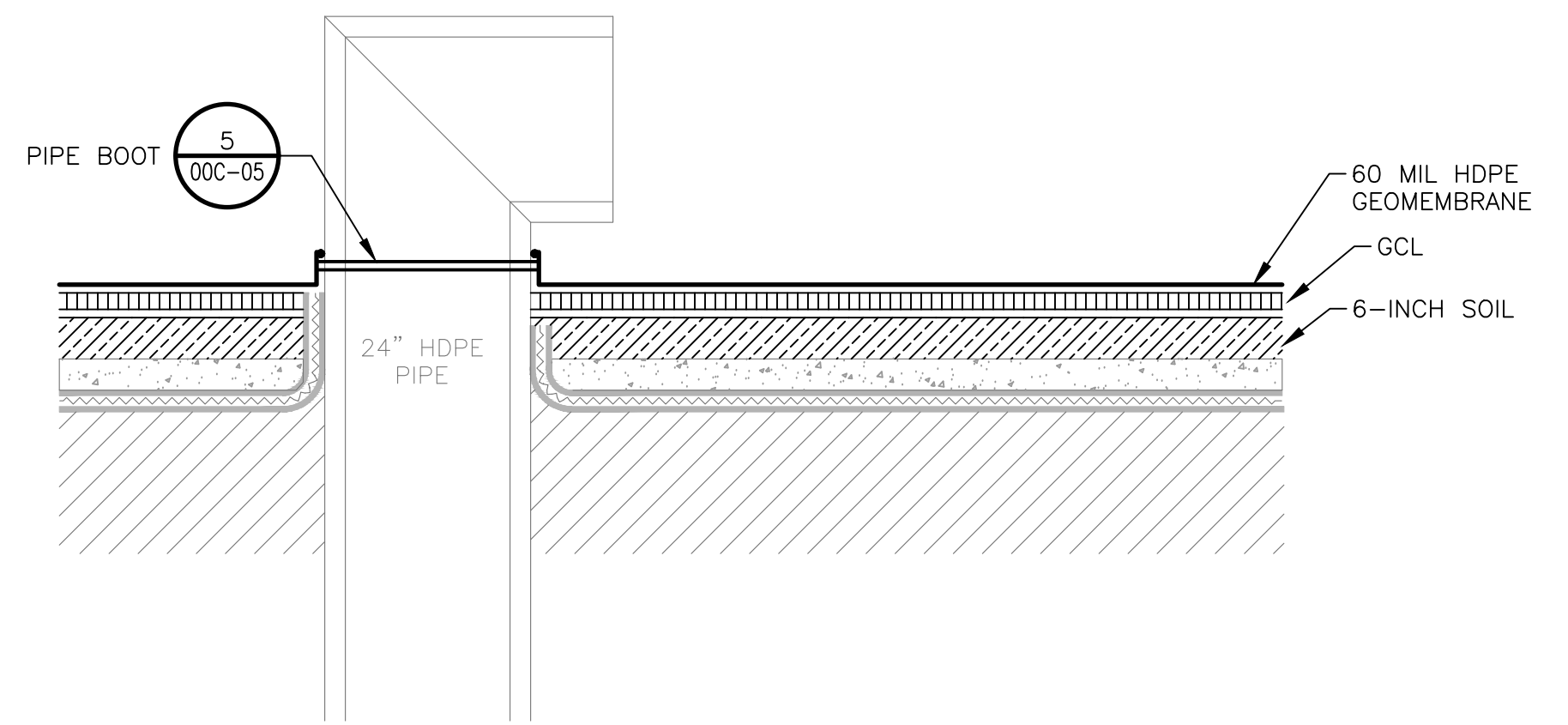

24" DEWATERING LINE INLET
NOT TO SCALE

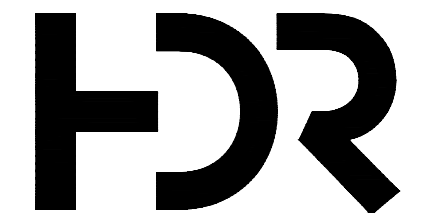

ISSUE	DATE	DESCRIPTION
F	01/29/2020	ISSUED FOR BID
E	01/23/2020	ISSUED FOR CLIENT REVIEW
D	01/14/2020	ISSUED FOR CLIENT REVIEW
C	12/20/2019	ISSUED FOR CLIENT REVIEW
B	11/26/2019	ISSUED FOR CLIENT REVIEW
A	11/12/2019	ISSUED FOR CLIENT REVIEW

PROJECT MANAGER	D. VOGT, P.E.
DESIGNED BY	K. PERERA
DRAWN BY	J. RAYMOND
CHECKED BY	M. ROBERTS
PROJECT NUMBER	10172630

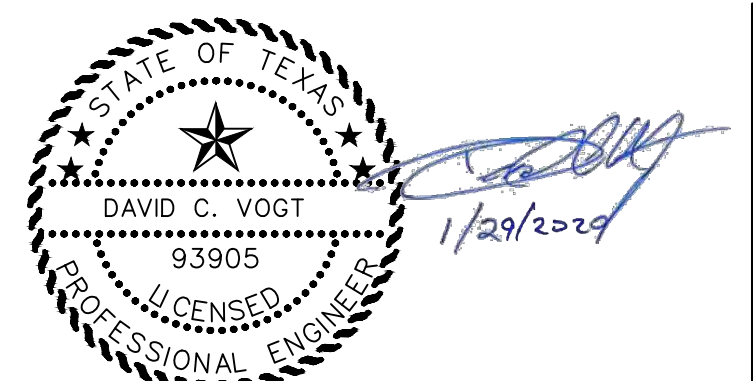

**MARTIN LAKE STEAM ELECTRICAL STATION
EAST ASH POND RELINE
RUSK COUNTY, TEXAS**



**DETAILS
(2 OF 2)**

FILENAME | 00C-05.dwg
SCALE | NOT TO SCALE

SHEET
00C-05

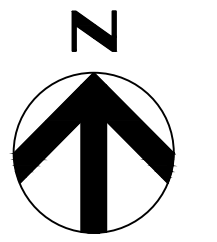
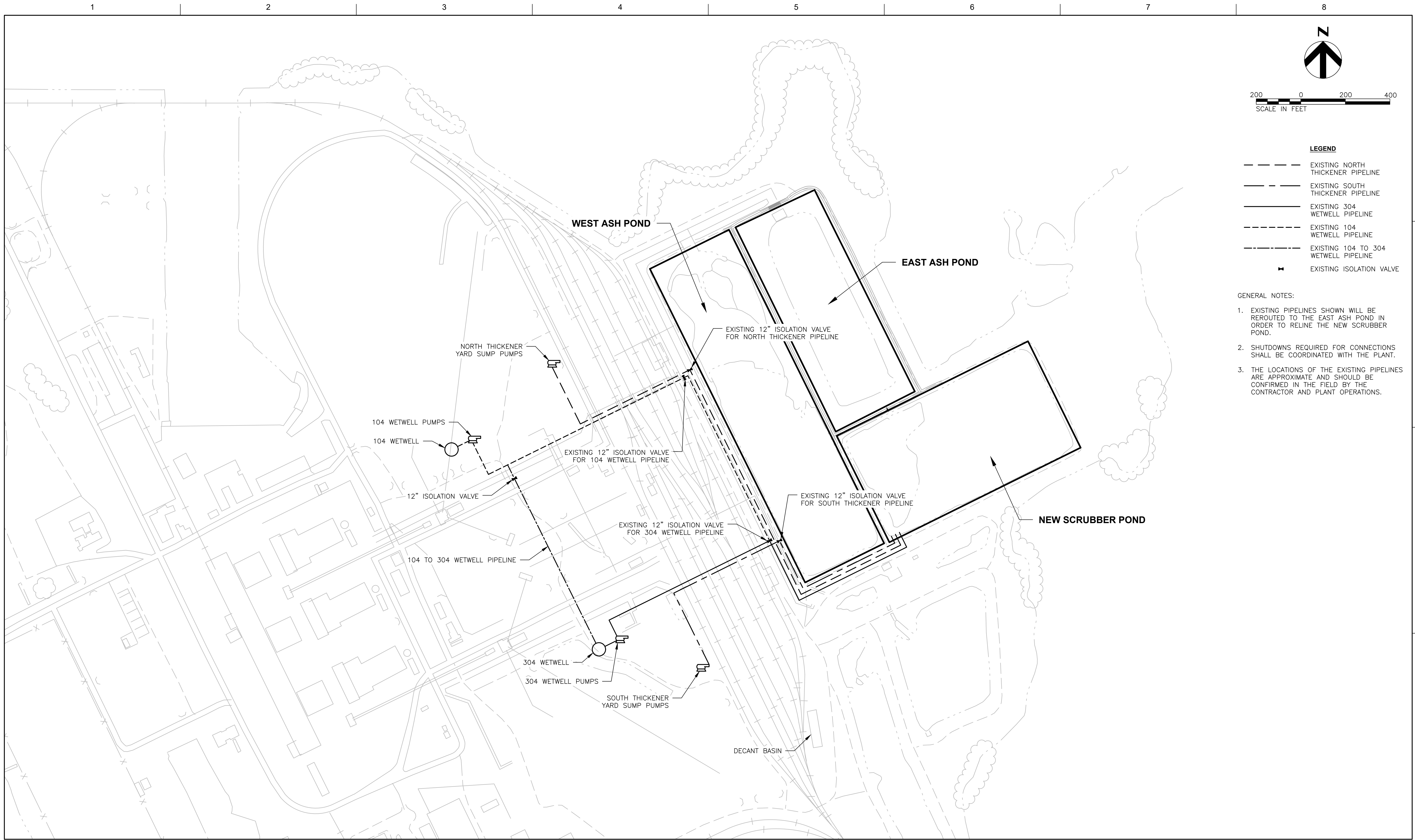

200 0 200 400
SCALE IN FEET

LEGEND

- EXISTING NORTH THICKENER PIPELINE
- EXISTING SOUTH THICKENER PIPELINE
- EXISTING 304 WETWELL PIPELINE
- EXISTING 104 WETWELL PIPELINE
- EXISTING 104 TO 304 WETWELL PIPELINE
- ◀ EXISTING ISOLATION VALVE

GENERAL NOTES:

1. EXISTING PIPELINES SHOWN WILL BE REROUTED TO THE EAST ASH POND IN ORDER TO RELINE THE NEW SCRUBBER POND.
2. SHUTDOWNS REQUIRED FOR CONNECTIONS SHALL BE COORDINATED WITH THE PLANT.
3. THE LOCATIONS OF THE EXISTING PIPELINES ARE APPROXIMATE AND SHOULD BE CONFIRMED IN THE FIELD BY THE CONTRACTOR AND PLANT OPERATIONS.



ISSUE	DATE	DESCRIPTION
F	01/29/2020	ISSUED FOR BID
E	01/23/2020	ISSUED FOR CLIENT REVIEW
D	01/14/2020	ISSUED FOR CLIENT REVIEW
C	12/20/2019	ISSUED FOR CLIENT REVIEW
B	11/26/2019	ISSUED FOR CLIENT REVIEW
A	11/12/2019	ISSUED FOR CLIENT REVIEW

PROJECT MANAGER	D. VOGT, P.E.
DESIGNED BY	J. ORDONEZ, P.E.
DRAWN BY	J. RAYMOND
CHECKED BY	D. VOGT, P.E.
PROJECT NUMBER	10172630

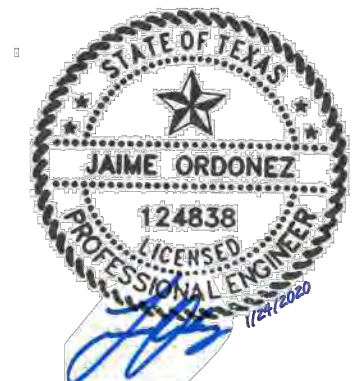

**MARTIN LAKE STEAM ELECTRICAL STATION
EAST ASH POND RELINE
RUSK COUNTY, TEXAS**



EXISTING YARD PIPING

0 1" 2"
SCALE

FILENAME | 00C-06.dwg
SCALE | 1" = 200'

SHEET
00C-06

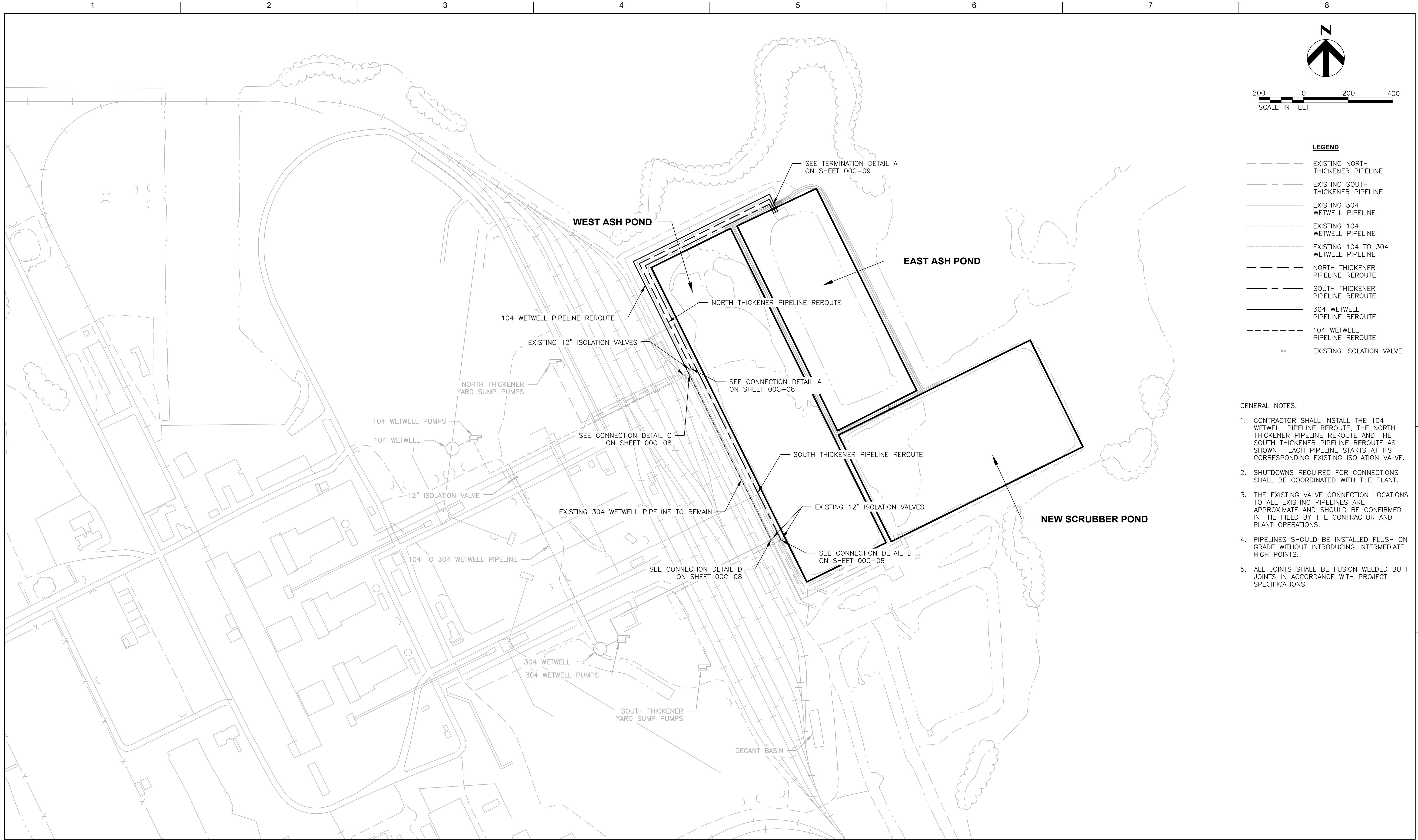

- LEGEND**
- EXISTING NORTH THICKENER PIPELINE
 - EXISTING SOUTH THICKENER PIPELINE
 - EXISTING 304 WETWELL PIPELINE
 - EXISTING 104 WETWELL PIPELINE
 - EXISTING 104 TO 304 WETWELL PIPELINE
 - NORTH THICKENER PIPELINE REROUTE
 - SOUTH THICKENER PIPELINE REROUTE
 - 304 WETWELL PIPELINE REROUTE
 - 104 WETWELL PIPELINE REROUTE
 - EXISTING ISOLATION VALVE

- GENERAL NOTES:**
1. CONTRACTOR SHALL INSTALL THE 104 WETWELL PIPELINE REROUTE, THE NORTH THICKENER PIPELINE REROUTE AND THE SOUTH THICKENER PIPELINE REROUTE AS SHOWN. EACH PIPELINE STARTS AT ITS CORRESPONDING EXISTING ISOLATION VALVE.
 2. SHUTDOWNS REQUIRED FOR CONNECTIONS SHALL BE COORDINATED WITH THE PLANT.
 3. THE EXISTING VALVE CONNECTION LOCATIONS TO ALL EXISTING PIPELINES ARE APPROXIMATE AND SHOULD BE CONFIRMED IN THE FIELD BY THE CONTRACTOR AND PLANT OPERATIONS.
 4. PIPELINES SHOULD BE INSTALLED FLUSH ON GRADE WITHOUT INTRODUCING INTERMEDIATE HIGH POINTS.
 5. ALL JOINTS SHALL BE FUSION WELDED BUTT JOINTS IN ACCORDANCE WITH PROJECT SPECIFICATIONS.

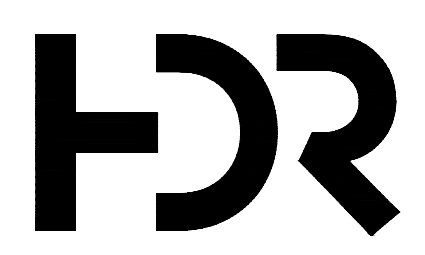

ISSUE	DATE	DESCRIPTION
F	01/29/2020	ISSUED FOR BID
E	01/23/2020	ISSUED FOR CLIENT REVIEW
D	01/14/2020	ISSUED FOR CLIENT REVIEW
C	12/20/2019	ISSUED FOR CLIENT REVIEW
B	11/26/2019	ISSUED FOR CLIENT REVIEW
A	11/12/2019	ISSUED FOR CLIENT REVIEW

PROJECT MANAGER	D. VOGT, P.E.
DESIGNED BY	J. ORDONEZ, P.E.
DRAWN BY	J. RAYMOND
CHECKED BY	D. VOGT, P.E.
PROJECT NUMBER	10172630

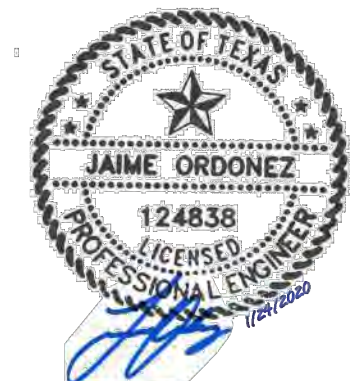

**MARTIN LAKE STEAM ELECTRICAL STATION
EAST ASH POND RELINE
RUSK COUNTY, TEXAS**



MODIFIED YARD PIPING

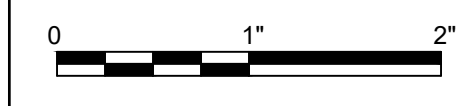

FILENAME | 00C-07.dwg
SCALE | 1" = 200'

SHEET
00C-07

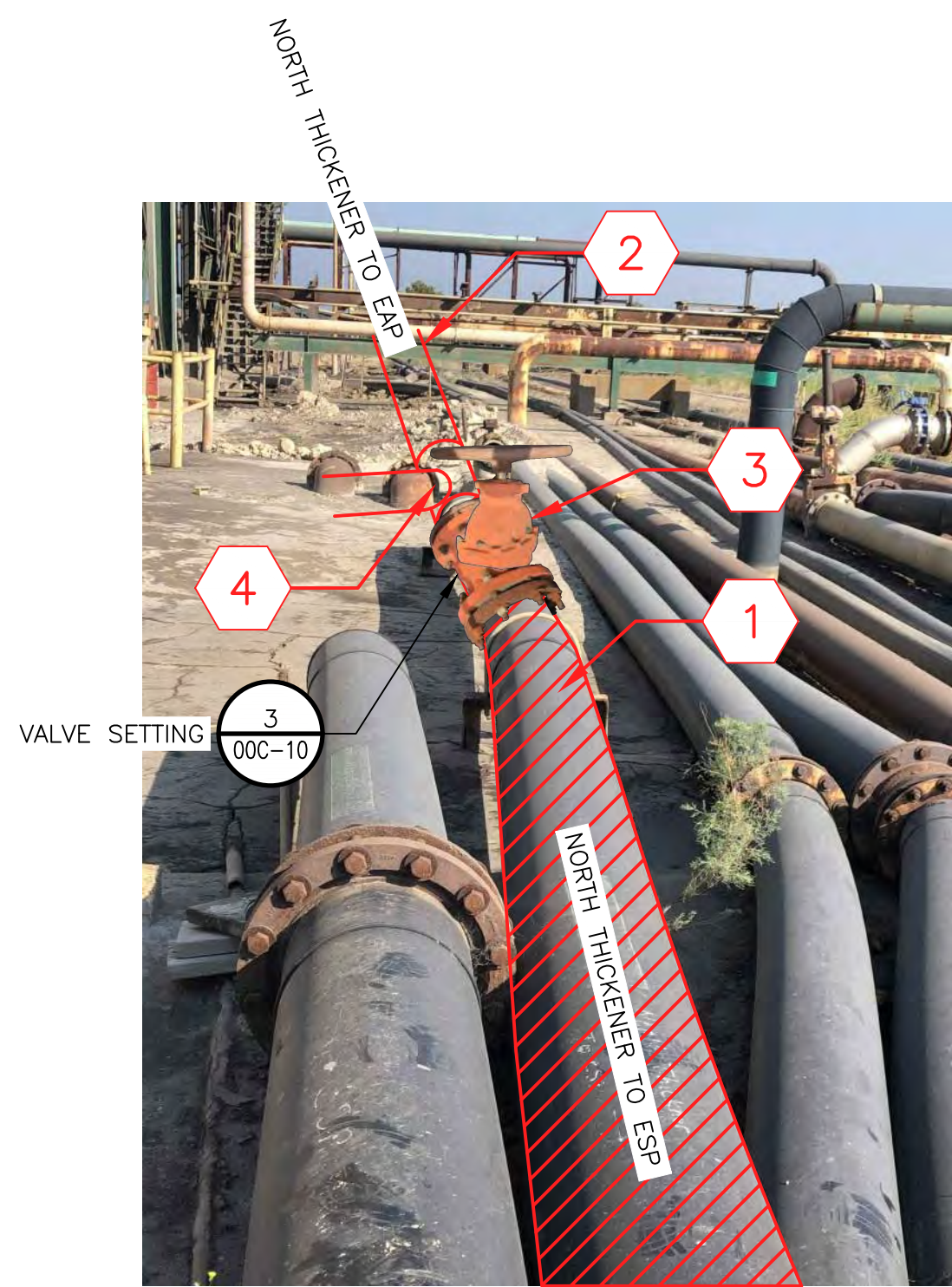

CONNECTION TO NORTH THICKENER PIPELINE A
NOT TO SCALE 00C-07

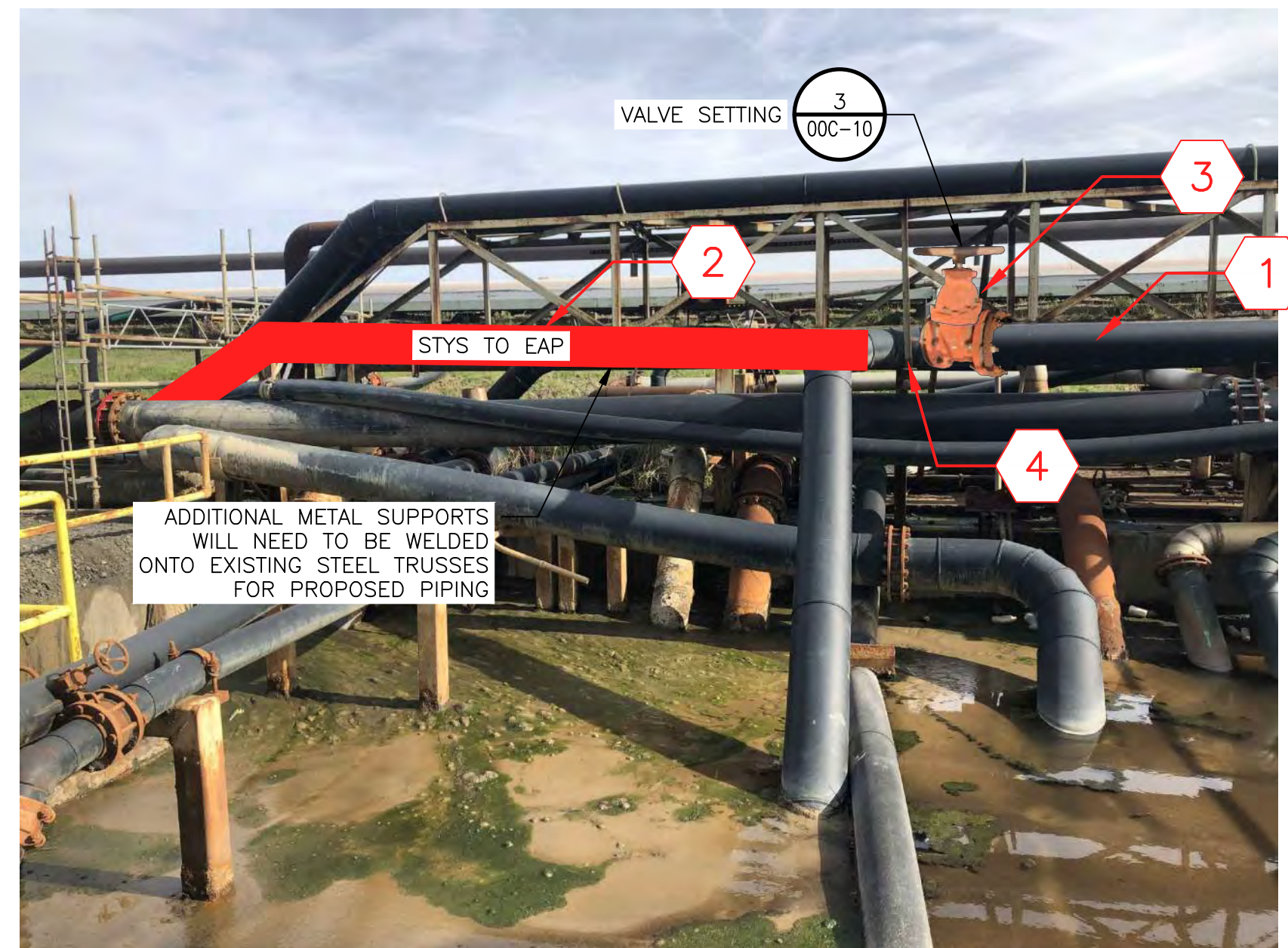

CONNECTION TO SOUTH THICKENER PIPELINE B
NOT TO SCALE 00C-07

- GENERAL NOTES:
1. SHUTDOWNS REQUIRED FOR CONNECTIONS SHALL BE COORDINATED WITH THE PLANT.
 2. THE CONNECTIONS LOCATION TO ALL EXISTING PIPELINES ARE APPROXIMATE AND SHOULD BE CONFIRMED IN THE FIELD BY THE CONTRACTOR AND PLANT OPERATIONS.
 3. CONNECTIONS C AND D MUST BOTH BE COMPLETE BEFORE MAKING EITHER OF THESE LINES OPERATIONAL.
 4. ALL PIPE AND FITTING SIZES SHALL BE CONFIRMED IN THE FIELD BY THE CONTRACTOR PRIOR TO ORDERING OR MANUFACTURING OF PIPE.

- KEY NOTES:
- 1 EXISTING TO REMAIN
 - 2 PIPELINE REROUTE
 - 3 12" ISOLATION VALVE
 - 4 INSTALL SIZE ON SIZE TEE

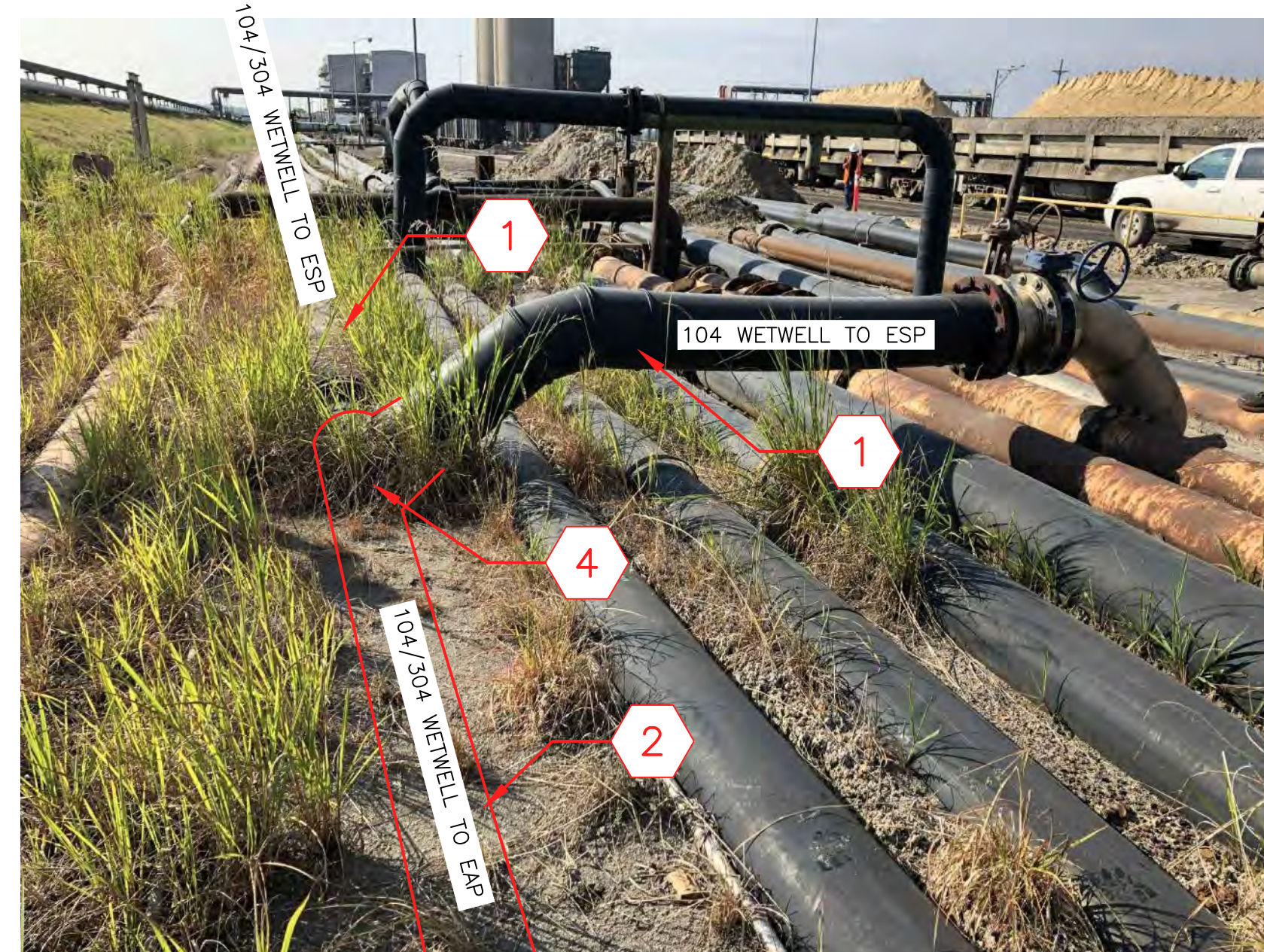

CONNECTION TO 104 WETWELL TO ESP PIPELINE C
NOT TO SCALE 00C-07



CONNECTION TO 304 WETWELL TO ESP PIPELINE C
NOT TO SCALE 00C-07

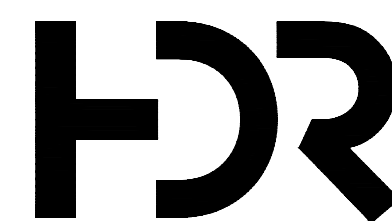

ISSUE	DATE	DESCRIPTION
F	01/29/2020	ISSUED FOR BID
E	01/23/2020	ISSUED FOR CLIENT REVIEW
D	01/14/2020	ISSUED FOR CLIENT REVIEW
C	12/20/2019	ISSUED FOR CLIENT REVIEW
B	11/26/2019	ISSUED FOR CLIENT REVIEW
A	11/12/2019	ISSUED FOR CLIENT REVIEW

PROJECT MANAGER	D. VOGT, P.E.
DESIGNED BY	J. ORDONEZ, P.E.
DRAWN BY	J. RAYMOND
CHECKED BY	D. VOGT, P.E.
PROJECT NUMBER	10172630



**MARTIN LAKE STEAM ELECTRICAL STATION
EAST ASH POND RELINE
RUSK COUNTY, TEXAS**



YARD PIPING CONNECTIONS AND DETAILS



FILENAME | 00C-08.dwg
SCALE | NOT TO SCALE

SHEET
00C-08

- GENERAL NOTES:
- EXISTING PIPELINES SHOWN SHALL BE REROUTED TO THE EAST ASH POND IN ORDER TO RELINE THE NEW SCRUBBER POND.
 - SHUTDOWNS REQUIRED FOR CONNECTIONS SHALL BE COORDINATED WITH THE PLANT.
 - THE CONNECTIONS LOCATION TO ALL EXISTING PIPELINES ARE APPROXIMATE AND SHOULD BE CONFIRMED IN THE FIELD BY THE CONTRACTOR AND PLANT OPERATIONS.
 - ALL JOINTS SHALL BE FUSION WELDED BUTT JOINTS IN ACCORDANCE WITH PROJECT SPECIFICATIONS, UNLESS OTHERWISE NOTED.
 - ALL PIPE AND FITTING SIZES SHALL BE CONFIRMED IN THE FIELD BY THE CONTRACTOR PRIOR TO ORDERING OR MANUFACTURING OF PIPE.



TERMINATION DETAIL A AT EXISTING PIPE RACK A
 NOT TO SCALE 00C-08

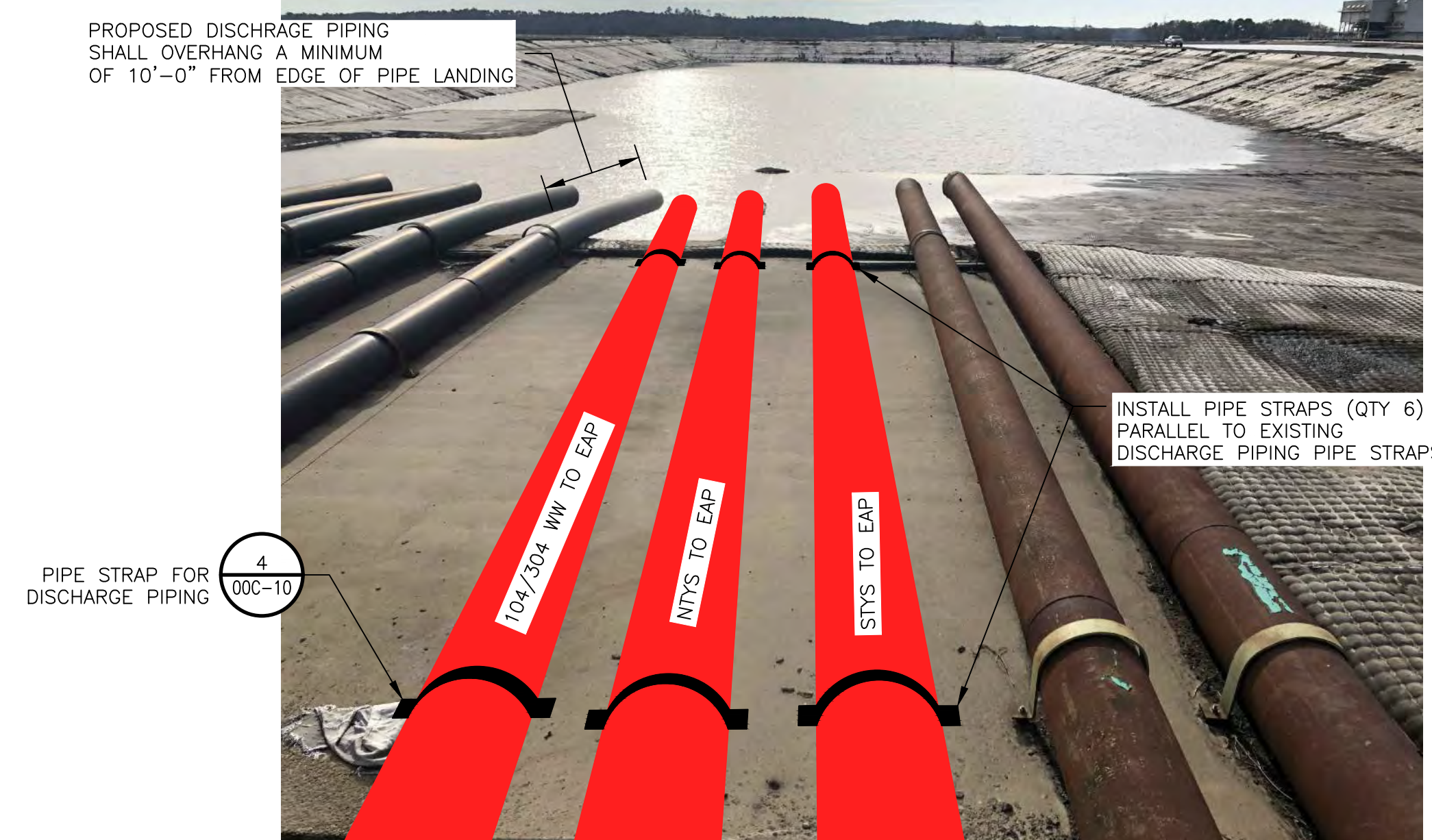

TERMINATION DETAIL B AT EXISTING PIPE RACK B
 NOT TO SCALE 00C-09



TERMINATION DETAIL C AT EXISTING PIPE RACK C
 NOT TO SCALE 00C-09

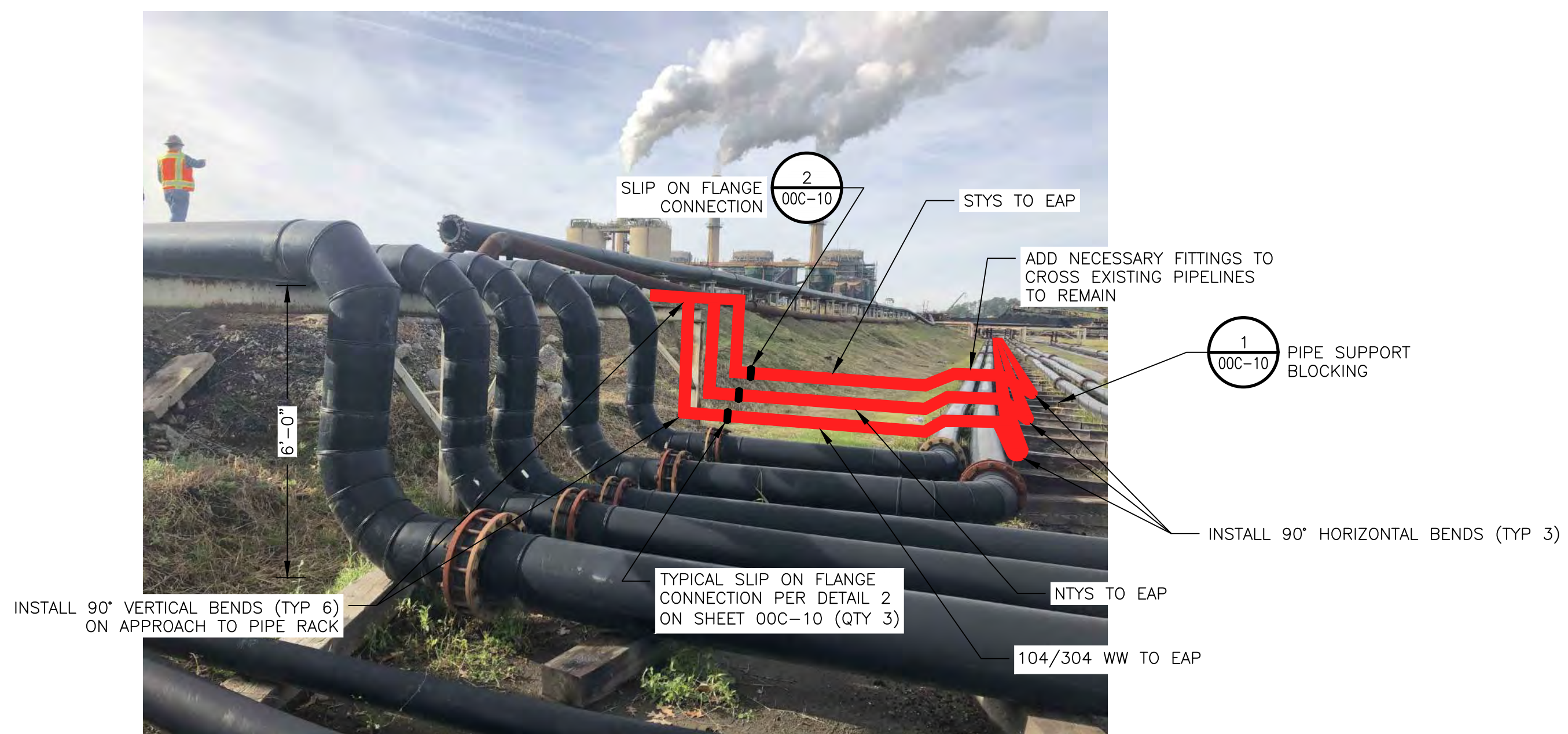

TERMINATION DETAIL D AT EXISTING PIPE RACK D
 NOT TO SCALE 00C-09

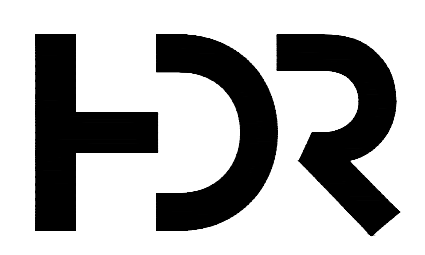

ISSUE	DATE	DESCRIPTION
F	01/29/2020	ISSUED FOR BID
E	01/23/2020	ISSUED FOR CLIENT REVIEW
D	01/14/2020	ISSUED FOR CLIENT REVIEW
C	12/20/2019	ISSUED FOR CLIENT REVIEW
B	11/26/2019	ISSUED FOR CLIENT REVIEW
A	11/12/2019	ISSUED FOR CLIENT REVIEW

PROJECT MANAGER	D. VOGT, P.E.
DESIGNED BY	J. ORDONEZ, P.E.
DRAWN BY	J. RAYMOND
CHECKED BY	D. VOGT, P.E.
PROJECT NUMBER	10172630

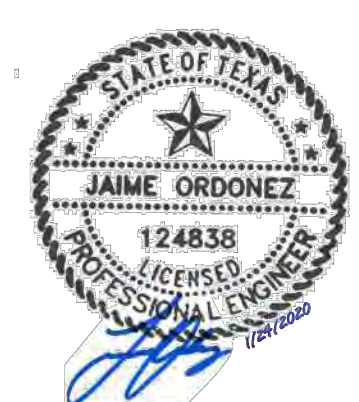

**MARTIN LAKE STEAM ELECTRICAL STATION
 EAST ASH POND RELINE
 RUSK COUNTY, TEXAS**



YARD PIPING CONNECTIONS AND DETAILS



FILENAME | 00C-09.dwg
 SCALE | NOT TO SCALE

SHEET
00C-09

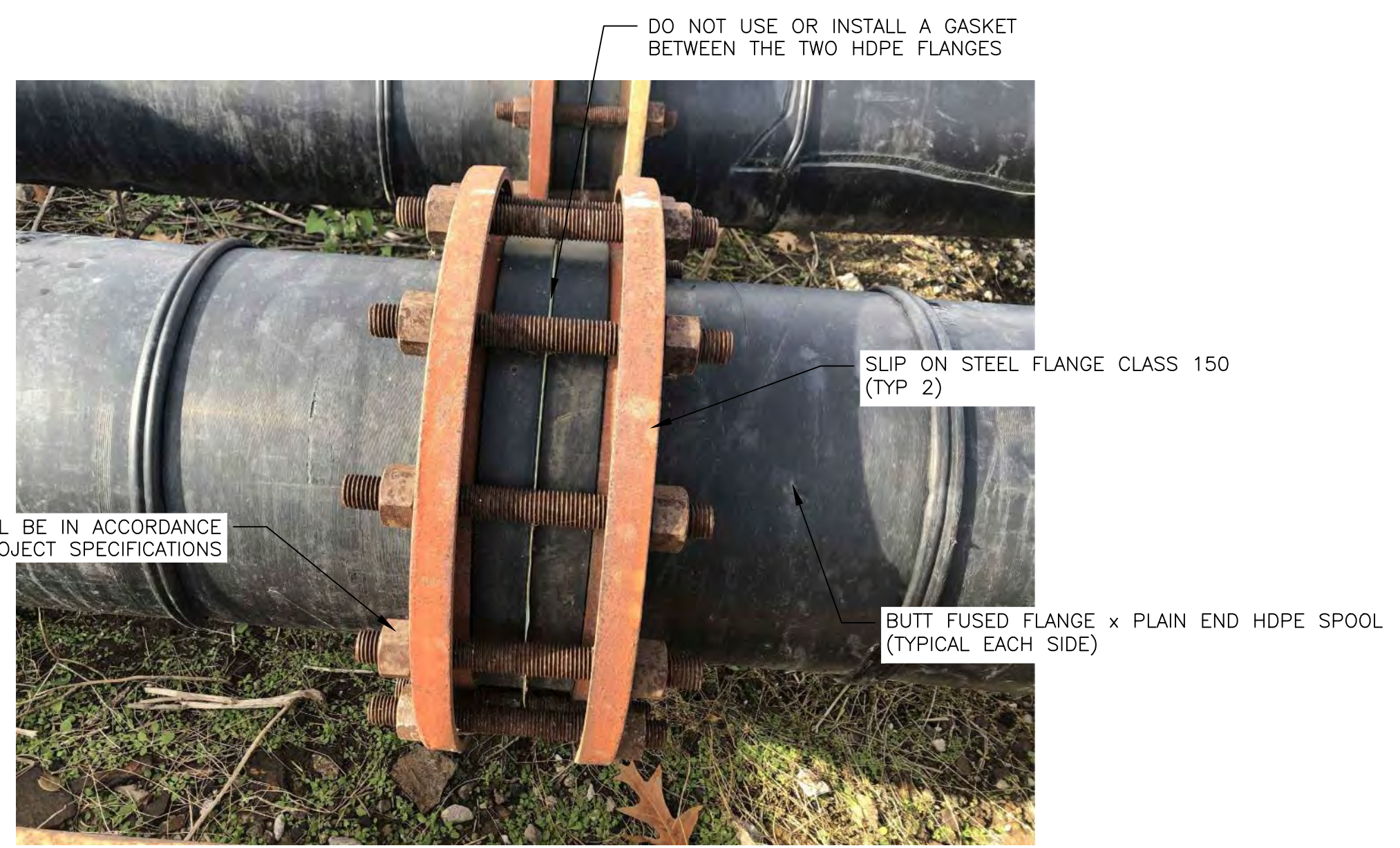
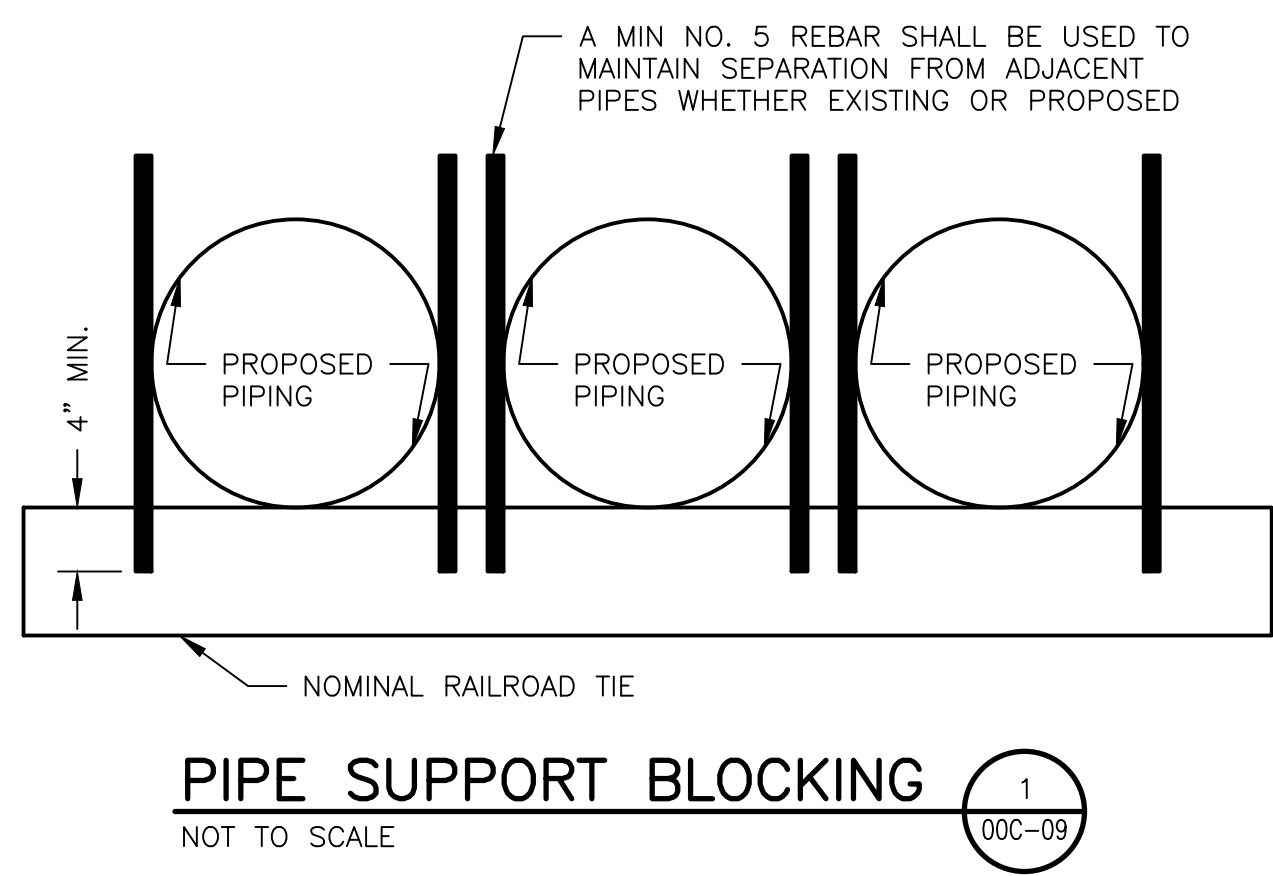

SLIP ON FLANGE CONNECTION 2
NOT TO SCALE 00C-09

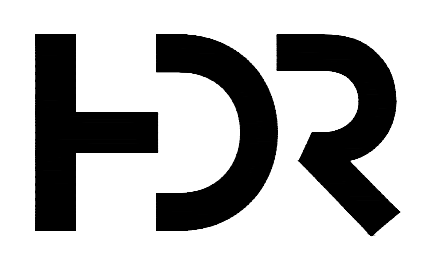
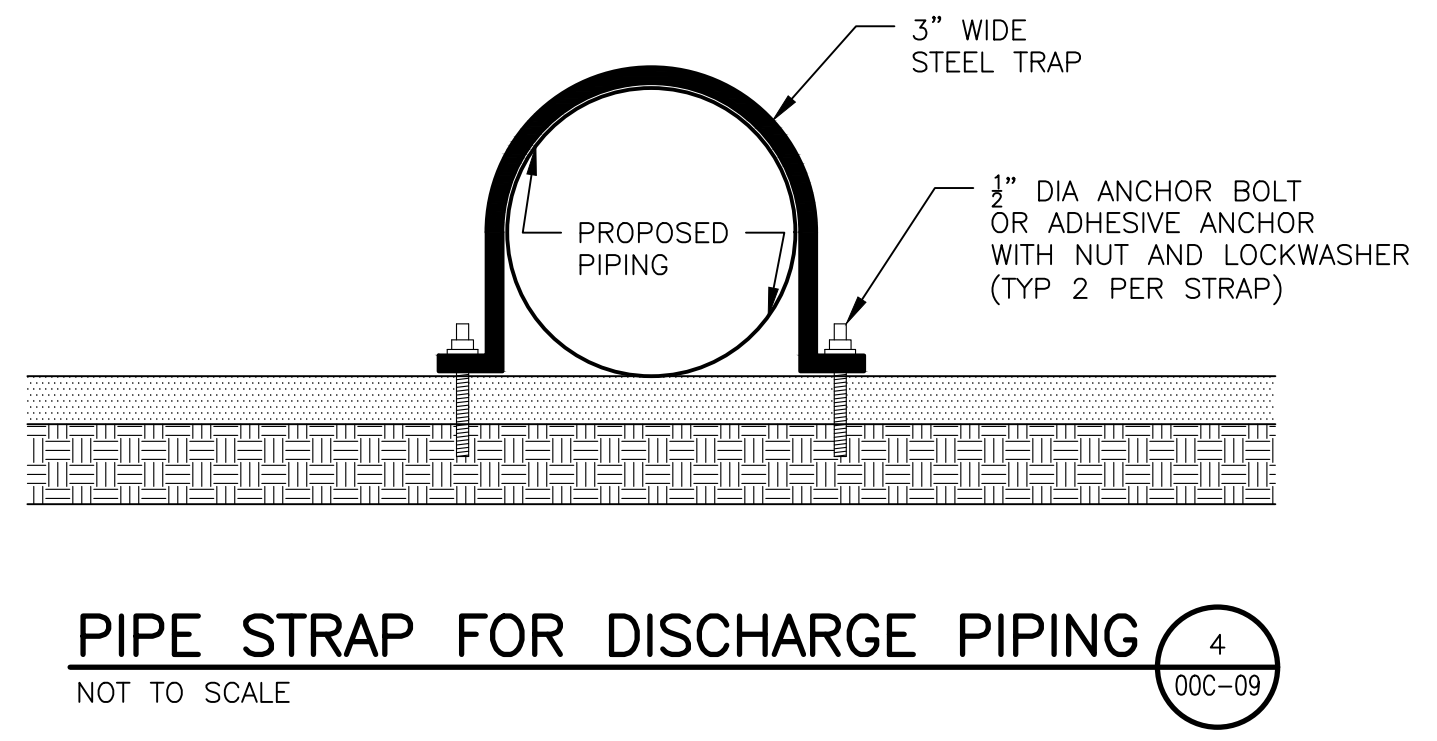
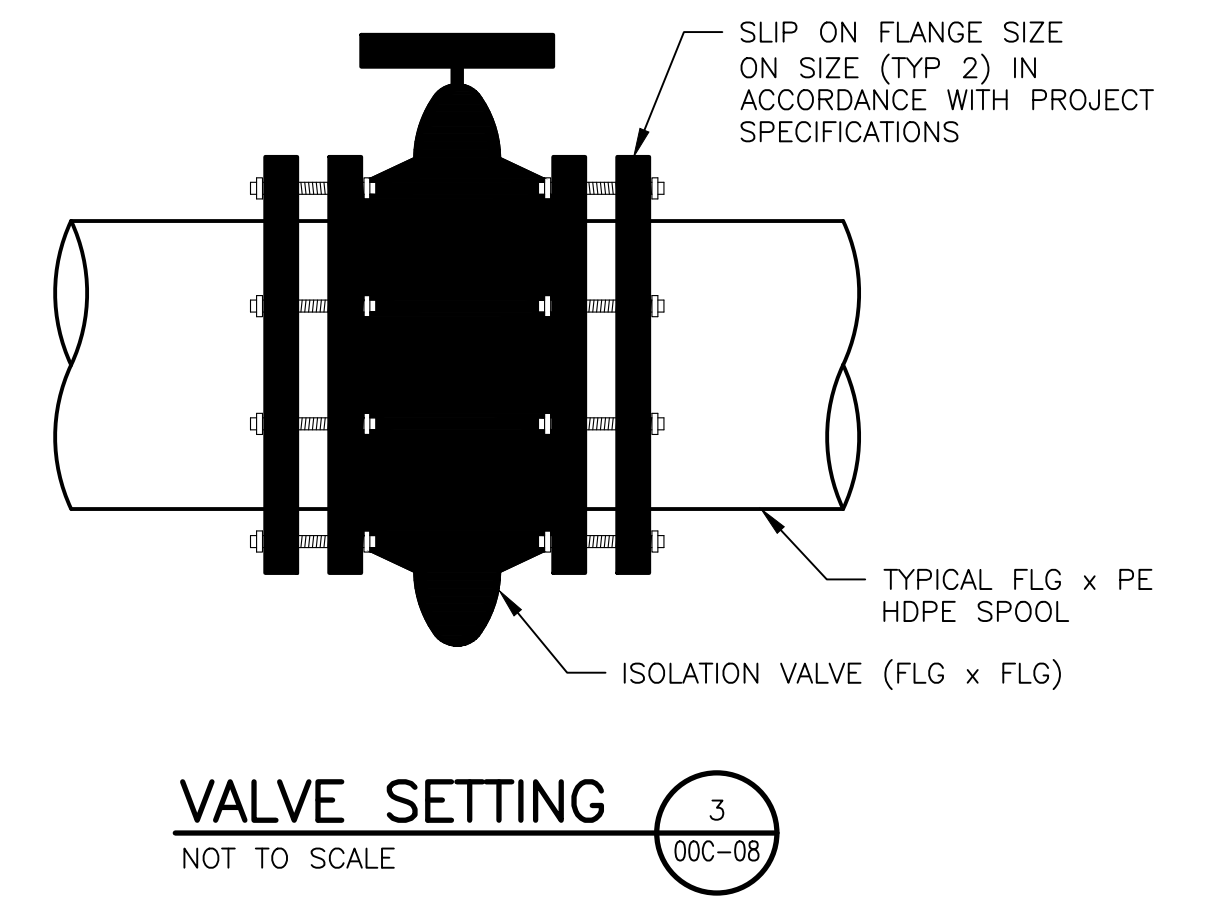

ISSUE	DATE	DESCRIPTION
F	01/29/2020	ISSUED FOR BID
E	01/23/2020	ISSUED FOR CLIENT REVIEW
D	01/14/2020	ISSUED FOR CLIENT REVIEW
C	12/20/2019	ISSUED FOR CLIENT REVIEW
B	11/26/2019	ISSUED FOR CLIENT REVIEW
A	11/12/2019	ISSUED FOR CLIENT REVIEW

PROJECT MANAGER	D. VOGT, P.E.
DESIGNED BY	J. ORDONEZ, P.E.
DRAWN BY	J. RAYMOND
CHECKED BY	D. VOGT, P.E.
PROJECT NUMBER	10172630

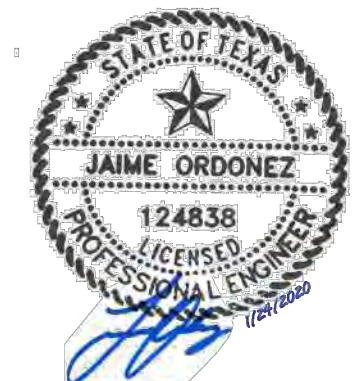

**MARTIN LAKE STEAM ELECTRICAL STATION
EAST ASH POND RELINE
RUSK COUNTY, TEXAS**



YARD PIPING DETAILS



FILENAME 00C-10.dwg
SCALE NOT TO SCALE

SHEET
00C-10



N

600 0 600 1200
SCALE IN FEET

LEGEND

- LIMITS OF CONSTRUCTION
- - - LIMITS OF PDP 5
- HAUL ROUTE

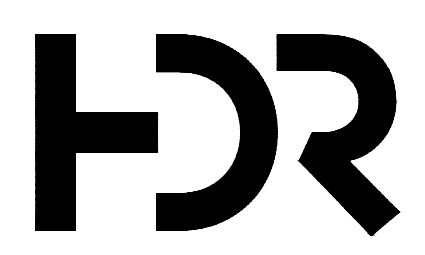

ISSUE	DATE	DESCRIPTION
F	01/29/2020	ISSUED FOR BID
E	01/23/2020	ISSUED FOR CLIENT REVIEW
D	01/14/2020	ISSUED FOR CLIENT REVIEW
C	12/20/2019	ISSUED FOR CLIENT REVIEW
B	11/26/2019	ISSUED FOR CLIENT REVIEW
A	11/12/2019	ISSUED FOR CLIENT REVIEW

PROJECT MANAGER	D. VOGT, P.E.
DESIGNED BY	K. PERERA
DRAWN BY	J. RAYMOND
CHECKED BY	M. ROBERTS
PROJECT NUMBER	10172630

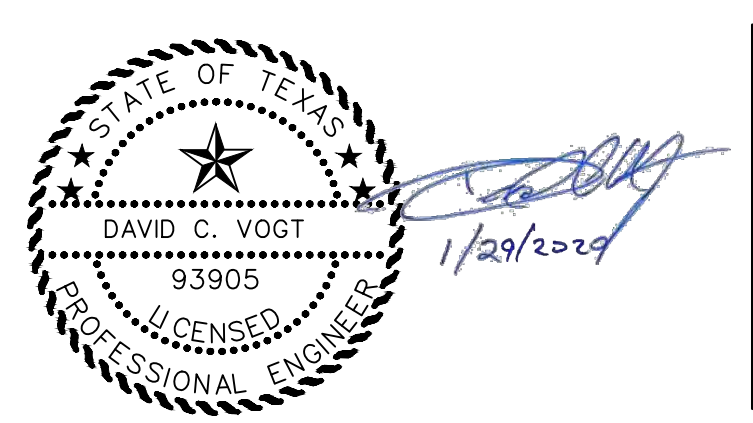

**MARTIN LAKE STEAM ELECTRICAL STATION
EAST ASH POND RELINE
RUSK COUNTY, TEXAS**



STOCKPILE AND HAUL ROUTE

0 1" 2"

FILENAME | 00C-11.dwg
SCALE | 1" = 600'

SHEET
00C-11

APPENDIX D – WEST ASH POND RETROFIT DESIGN DRAWINGS

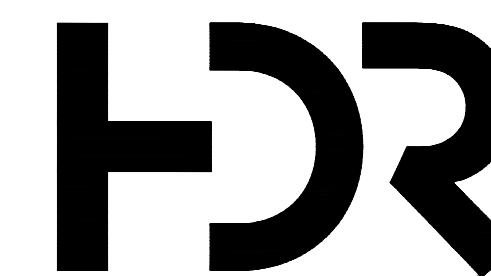

HDR
 Firm Registration No. F-754
 17111 Preston Road, Suite 300
 Dallas, Texas 75248-1229
 972.960.4400



Construction Drawings For

Martin Lake Steam Electric Station

CCR Impoundment Reline West Ash Pond

Project No.
 10172630

Rusk County, Texas
 January 2020

INDEX OF DRAWINGS

GENERAL	
00G-01	COVER SHEET
00G-02	ABBREVIATIONS AND GENERAL NOTES
CIVIL	
00C-01	SITE LAYOUT
00C-02	WEST ASH POND
00C-03	CROSS SECTIONS
00C-04	DETAILS (1 OF 2)
00C-05	DETAILS (2 OF 2)
00C-06	STOCKPILE AND HAUL ROUTE



VICINITY MAP
 NOT TO SCALE

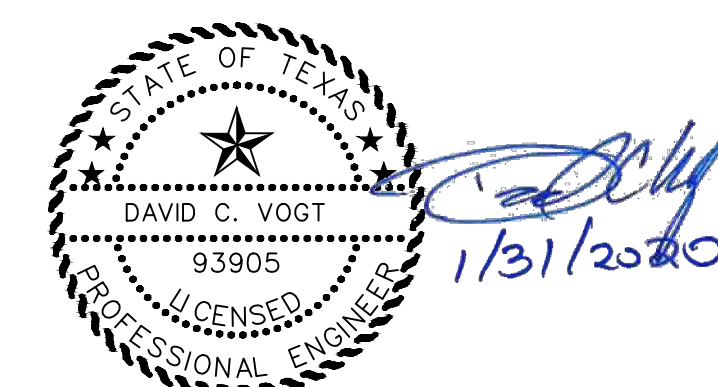

STANDARD ABBREVIATIONS

&	AND	NTS	NOT TO SCALE
APPROX	APPROXIMATELY	NTYS	NORTH THICKENER YARD SUMP
@	AT	OC	ON CENTER
AVG	AVERAGE	OZ	OUNCE
BOE	BOTTOM OF EXCAVATION	%	PERCENT
BOL	BOTTOM OF LINER	PLCP	PERFORATED LEACHATE COLLECTION PIPE
X	BY	PERF	PERFORATED
CL	CENTERLINE	PGL	PROFILE GRADE LINE
CMP	CORRUGATED METAL PIPE	PDP	PERMANENT DISPOSAL POND
CO	CLEAN OUT	PC	POINT OF CURVATURE
CY	CUBIC YARD	PI	POINT OF INTERSECTION
DIA	DIAMETER	PVI	POINT OF VERTICAL INTERSECTION
DET	DETAIL	PT	POINT OF TANGENT
DWG	DRAWING	PZ	PIEZOMETER
E	EAST	Q	FLOW
EAP	EAST ASH POND	QTY	QUANTITY
ELEV	ELEVATION	R	RADIUS
EW	EACH WAY	RCP	REINFORCED CONCRETE PIPE
EXIST	EXISTING	REF	REFERENCE
EXC	EXCAVATION	REQ	REQUIRED
FGD	FLUE GAS DESULFICATION	RD	ROAD
FML	FLEXIBLE MEMBRANE LINER	SCH	SCHEDULE
FT	FEET	SDL	SAND DRAINAGE LAYER
GAL	GALLON	SEC	SECTION
GND	GROUND	SHT	SHEET
GDL	GRAVEL DRAINAGE LAYER	S	SOUTH
GNDL	GEONET DRAINAGE LAYER	SDR	STANDARD DIMENSION RATIO
HDPE	HIGH DENSITY POLYETHYLENE	SLQCP	SOIL LINER QUALITY CONTROL PLAN
HORIZ	HORIZONTAL	SP	STEEL PIPE
ID	INSIDE DIAMETER	SQ	SQUARE
IN	INCHES	SS	SIDE SLOPE
IE	INVERT ELEVATION	STA	STATION
LCRS	LEACHATE COLLECTION AND REMOVAL SYSTEM	STYS	SOUTH THICKENER YARD SUMP
LCS	LEACHATE COLLECTION SYSTEM	T.A.S.	TERMINAL ANCHOR SECTION
LCP	LEACHATE COLLECTION PIPE	TL	TANGENT LENGTH
LCPR	LEACHATE COLLECTION PIPE RISER	TOC	TOP OF COVER
LF	LINEAR FEET	TOFC	TOP OF FINAL COVER
LB	POUND	TOL	TOP OF LINER
MH	MANHOLE	TOS	TOE OF SLOPE
MAX	MAXIMUM	TS	TOP SLOPE
MIL	.001 INCHES	TEMP	TEMPORARY
MIN	MINIMUM	TYP	TYPICAL
MW	MONITOR WELL	UNO	UNLESS NOTED OTHERWISE
MLSES	MARTIN LAKE STEAM ELECTRIC STATION	VERT	VERTICAL
MSL	MEAN SEA LEVEL	W	WEST
N	NORTH	W/	WITH
NIC	NOT IN CONTRACT	WAP	WEST ASH POND
NO	NUMBER	WW	WETWELL
		YD	YARD

CONSTRUCTION SEQUENCE

- A. CONTRACTOR SHALL CLEAN THE WAP BY REMOVING ANY REMAINING CCR MATERIAL, ROCKS, AND SEDIMENT.
- B. CONTRACTOR SHALL USE WATER FROM THE ADJACENT EAST ASH POND (EAP) OR NEW SCRUBBER POND (SP) TO WASH REMAINING CCR MATERIAL OFF THE SIDES AND FLOOR OF THE WAP AND REMOVE IT. EAP WILL BE VISUALLY INSPECTED BY OWNER'S COA CONSULTANT TO CONFIRM CCR MATERIAL, ROCKS, AND SEDIMENT HAVE BEEN REMOVED.
- C. CONTRACTOR SHALL LOAD AND HAUL GENERAL SOIL FILL MATERIAL FROM THE OWNER'S STOCKPILE LOCATED AT LIBERTY MINE, A LOCATION UNDER THE PROVISIONS OF THE MINE SAFETY AND HEALTH ADMINISTRATION (MSHA) AND APPROXIMATELY 4.5 MILES FROM EAP.
- D. CONTRACTOR SHALL PLACE THE GENERAL FILL MATERIAL OVER THE EXISTING CONCRETE REVETMENT TO A DEPTH OF AT LEAST SIX (6) INCHES, NOMINALLY COMPACT, AND SMOOTH ROLL TO FINISH THE INSTALLATION.
- E. CONTRACTOR SHALL INSTALL A GEOSYNTHETIC CLAY LINER (GCL) OVER THE SIDES AND FLOOR OF THE WAP AND SECURE IT IN A PERIMETER ANCHOR TRENCH/BATTEN AND STRIP.
- F. CONTRACTOR SHALL INSTALL A 60-MIL HDPE LINER DIRECTLY ON THE GCL AND SECURE IT IN A PERIMETER ANCHOR TRENCH/BATTEN AND STRIP.

GENERAL NOTES

1. ALL WORK UNDER THIS CONTRACT SHALL BE PERFORMED IN ACCORDANCE WITH THE PLANS AND PROJECT SPECIFICATIONS. IN THE EVENT OF A DISCREPANCY BETWEEN THE PLANS AND THE PROJECT SPECIFICATIONS, THE SPECIFICATIONS SHALL GOVERN.
2. COORDINATE SYSTEM IS BASED ON LOCAL SURVEY. THE BENCHMARKS TO BE USED FOR CONSTRUCTION ARE LOCATED AS SHOWN ON DRAWING NO. 00G-01. EXISTING CONTOURS ARE BASED ON TOPOGRAPHICAL SURVEY PERFORMED FEBRUARY 12-20, 2019 BY LACY SURVEYING. CURRENT GROUND ELEVATIONS MAY VARY FROM THOSE SHOWN DUE TO SITE WORK THAT HAS BEEN PERFORMED SINCE THE SURVEY WAS PERFORMED.
3. THE CONTRACTOR SHALL VERIFY EXISTING CONTOURS PRIOR TO THE START OF WORK.
4. THERE SHALL NOT BE ANY ADDITIONAL PAYMENT OR EXTENSION OF CONTRACT TIME FOR WORKING WITH SATURATED SOILS OR HANDLING WATER SEEPAGE DUE TO RAINFALL, RUNOFF AND INFILTRATION.
5. THE CONTRACTOR SHALL TAKE ALL NECESSARY PRECAUTIONS TO PROTECT EXISTING ROADS, BENCHMARKS AND EXISTING GROUNDWATER MONITOR WELLS DURING THE CONSTRUCTION PERIOD. THE CONTRACTOR SHALL BE SOLELY RESPONSIBLE FOR ANY AND ALL DAMAGES WHICH MIGHT BE INCURRED BY THE CONTRACTOR'S FAILURE TO EXACTLY LOCATE AND PROTECT THE GROUNDWATER MONITOR WELLS, BENCHMARKS AND EXISTING ROADS.
6. THE LOCATIONS OF EXISTING UNDERGROUND UTILITIES HAVE NOT BEEN ESTABLISHED BY THE OWNER OR ENGINEER. THE CONTRACTOR SHALL DETERMINE THE EXACT LOCATION OF ALL EXISTING UTILITIES BEFORE COMMENCING WORK, AND AGREES TO BE FULLY RESPONSIBLE FOR ANY AND ALL DAMAGES WHICH MIGHT BE OCCASIONED BY THE CONTRACTORS FAILURE TO EXACTLY LOCATE AND PRESERVE ANY AND ALL UTILITIES. THE CONTRACTOR SHALL BE RESPONSIBLE FOR MAINTAINING PROPER SAFE WORKING DISTANCE FROM ALL UTILITY EASEMENTS OR LINES.
7. EXCAVATION BY "BLASTING" IS NOT PERMITTED ON THIS PROJECT.
8. FINISHED GROUND ELEVATIONS SHALL MATCH EXISTING GROUND ELEVATIONS EXCEPT AS SHOWN ON THE PLANS. ALL EXCESS SOIL FROM THE EXCAVATION AND GRADING SHALL BE PLACED IN DESIGNATED STOCKPILE LOCATIONS AS APPROVED BY THE OWNER. IF WASTE IS ENCOUNTERED DURING EXCAVATION, THE OWNER SHALL BE NOTIFIED AND THE WASTE REMOVED AND PLACED IN AREAS DESIGNATED AS APPROVED BY THE OWNER. TRANSPORT OF SOIL TO FILL AREAS SHALL BE CONDUCTED BY THE CONTRACTOR AT NO ADDITIONAL EXPENSE TO THE OWNER.
9. GEOTECHNICAL INVESTIGATION REPORTS FOR THE SITE ARE AVAILABLE FOR REVIEW AT LUMINANT'S DALLAS OFFICES. THE CONTRACTOR MAY PERFORM ADDITIONAL GEOTECHNICAL INVESTIGATIONS, AS DEEMED NECESSARY FOR CONSTRUCTION ACTIVITIES, PROVIDED ALL NECESSARY PERMITS AND APPROVALS ARE OBTAINED FROM LUMINANT PRIOR TO INITIATING SUCH WORK. HOWEVER, THERE SHALL BE NO ADDITIONAL PAYMENT TO THE CONTRACTOR FOR ADDITIONAL GEOTECHNICAL INVESTIGATIONS.
10. THE CONTRACTOR SHALL CONSTRUCT AND UPON COMPLETION OF THE PROJECT, REMOVE TEMPORARY CONSTRUCTION ACCESS ROADS. SUCH ROADS SHALL BE LOCATED AS APPROVED BY THE OWNER. DRAINAGE PATTERNS AT THE SITE SHALL NOT BE ALTERED BY ROAD CONSTRUCTION. THE CONTRACTOR SHALL BE RESPONSIBLE FOR CONSTRUCTION AND MAINTENANCE OF TEMPORARY DRAINAGE STRUCTURES, INCLUDING CULVERTS, AT NO ADDITIONAL COST TO THE OWNER.
11. THE CONTRACTOR SHALL INSTALL, MAINTAIN, AND UPON COMPLETION OF THE PROJECT, REMOVE TEMPORARY EROSION AND SEDIMENT CONTROLS AS PER SPECIFICATIONS DURING CONSTRUCTION. SUCH CONTROLS SHALL BE PLACED AT LIMITS OF DISTURBED AREAS AND AT INTERMEDIATE LOCATIONS WHERE CONCENTRATED FLOW IS LIKELY.
12. TEMPORARY CONSTRUCTION SLOPES SHALL NOT BE GREATER THAN 2H:1V. STEEPER SLOPES WILL ONLY BE ALLOWED IF THE CONTRACTOR PROVIDES A GEOTECHNICAL ENGINEERING REPORT SPECIFYING MAXIMUM SLOPES AND THE DURATION FOR WHICH SUCH SLOPES SHALL REMAIN IN PLACE.
13. THE CONTRACTOR SHALL REMOVE ALL VEGETATION WITHIN THE CONSTRUCTION LIMITS AS REQUIRED TO CONSTRUCT THE PROJECT. ALL VEGETATION SHALL BE REMOVED BY CONTRACTOR AT NO ADDITIONAL EXPENSE TO OWNER.
14. THE CONTRACTOR SHALL OBTAIN AND CONDUCT WORK CONSISTENT WITH A TPDES PERMIT FOR CONSTRUCTION, REFER TO TECHNICAL SPECIFICATIONS. PREPARATION OF A SWPPP AND OBTAINING THE TPDES PERMIT ARE THE CONTRACTORS RESPONSIBILITY.
15. THE CONTRACTOR SHALL IMMEDIATELY REPORT TO THE ENGINEER ANY ERROR OR DISCREPANCY FOUND ONCE THE CONTRACT DOCUMENT IS CAREFULLY REVIEWED AND ALL ASPECTS OF FIELD WORK HAVE BEEN VERIFIED. IN THE EVENT THE CONTRACTOR CONTINUES TO WORK ON AN ITEM WHERE AN ERROR EXISTS, IT SHALL BE DEEMED THAT THE CONTRACTOR BID AND INTENDED TO EXECUTE THE MORE STRINGENT OR HIGHER QUALITY REQUIREMENT WITHOUT AN INCREASE IN CONTRACT SUM OR TIME. THE CONTRACTOR SHALL ALSO BE RESPONSIBLE TO CORRECT ANY FAILURE OF COMPANY PARTS TO COORDINATE OR FIT PROPERLY INTO FINAL POSITION, AS A RESULT OF CONTRACTOR FAILURE TO RAISE OR RESOLVE A DISCREPANCY.
16. THE DRAWINGS AND SPECIFICATIONS SHOULD AGREE WITH EACH OTHER, AND WORK CALLED FOR BY DRAWINGS AND NOT MENTIONED IN SPECIFICATION, OR VICE VERSA, SHALL BE FURNISHED BY BOTH. WHEN DISCREPANCIES EXIST BETWEEN SCALE AND DIMENSIONS, THE DIMENSIONED FIGURE SHALL BE USED.
17. CONTRACTOR AND EACH SUBCONTRACTOR SHALL VERIFY ALL GRADES, LINES, LEVELS, AND DIMENSIONS AS INDICATED ON DRAWINGS, AND HE SHALL REPORT ERRORS TO THE ENGINEER BEFORE COMMENCING WORK. THE CONTRACTOR SHALL ESTABLISH BENCHMARKS IN AT LEAST TWO WIDELY SEPARATED PLACES, AND AS WORK PROGRESSES THE CONTRACTOR WILL MAINTAIN ADEQUATE HORIZONTAL AND VERTICAL CONTROL.
18. CONTRACTOR SHALL PROVIDE EROSION CONTROL BY SEEDING FOR ALL AREAS DISTURBED BY CONTRACTOR DURING THE CONSTRUCTION OF THIS PROJECT. THE CONTRACTOR SHALL NOT DISTURB ANY AREA WITHOUT THE APPROVAL OF THE ENGINEER. EROSION CONTROL BY SEEDING SHALL CONFORM TO STANDARD SPECIFICATION 02930.
19. CONTRACTOR SHALL INSTALL EROSION AND SEDIMENT CONTROLS AS PER SPECIFICATIONS DURING CONSTRUCTION. SUCH CONTROLS SHALL BE PLACED AT LIMITS OF DISTURBED AREAS AND AT INTERMEDIATE LOCATIONS WHERE CONCENTRATED FLOW IS LIKELY.
20. STORMWATER THAT HAS COME INTO CONTACT WITH THE ASH WITHIN THE EXCAVATED POND IS TO BE CONSIDERED CONTACT STORMWATER. CONTRACTOR WILL CONTROL THE WATER ON SITE IN COMPLIANCE WITH THE TPDES PERMIT.
21. THE CONTRACTOR IS REQUIRED TO PRESENT THE SWPPP TO LUMINANT ENVIRONMENTAL SERVICES FOR APPROVAL PRIOR TO THE COMMENCEMENT OF CONSTRUCTION ACTIVITIES.
22. THE CONTRACTOR IS REQUIRED TO SUBMIT THE NOTICE OF INTENT AND NOTICE OF TERMINATION FOR THE TPDES PERMIT.
23. THE CONTRACTOR IS TO ACQUIRE A DIGGING PERMIT FROM THE PLANT BEFORE COMMENCING ANY EXCAVATION ACTIVITY.

SYMBOLS

SECTION DETAIL INDICATORS

DRAWING ON WHICH SECTION IS CUT:

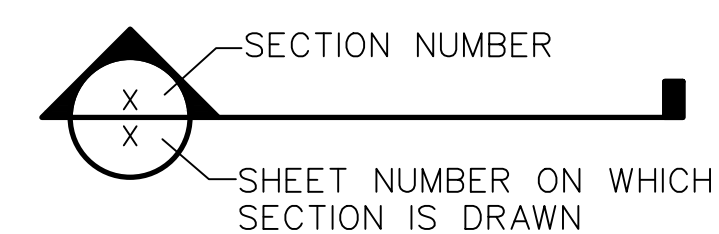

DRAWING ON WHICH SECTION APPEARS:

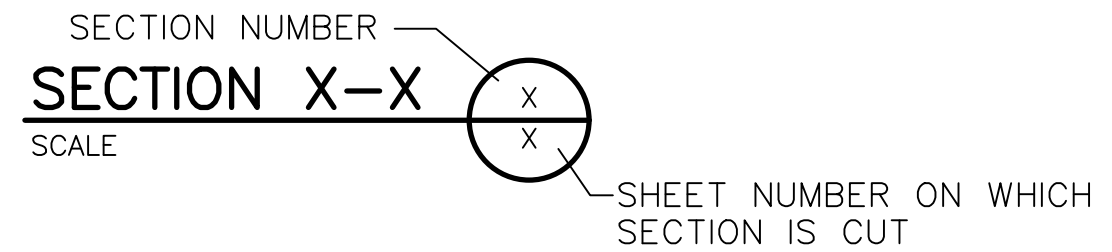

DRAWING ON WHICH DETAIL IS INDICATED:

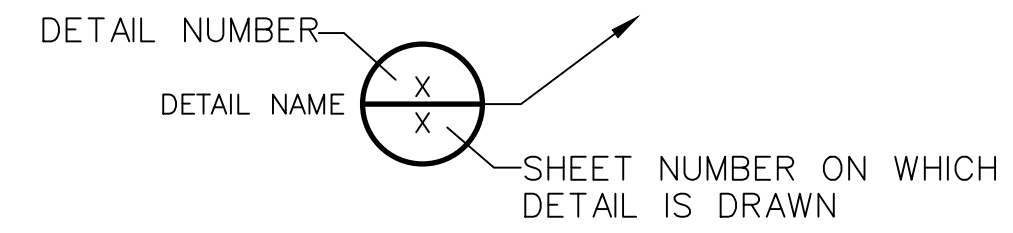

DRAWING ON WHICH DETAIL APPEARS:

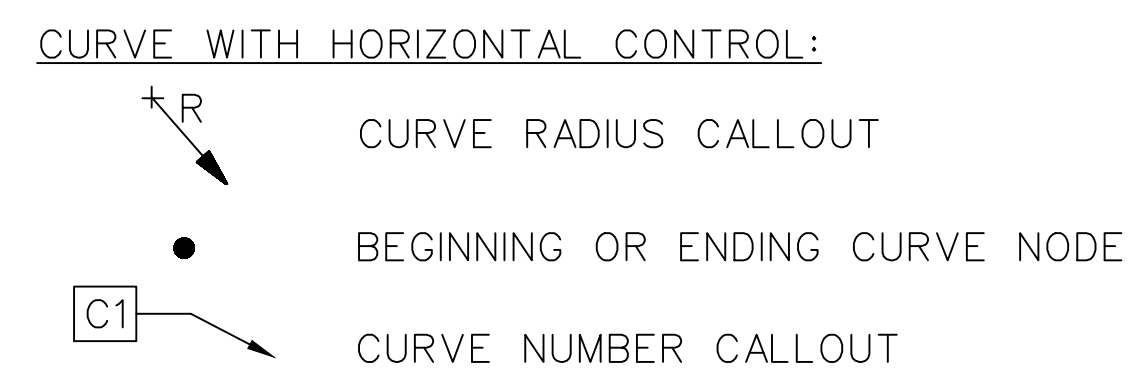
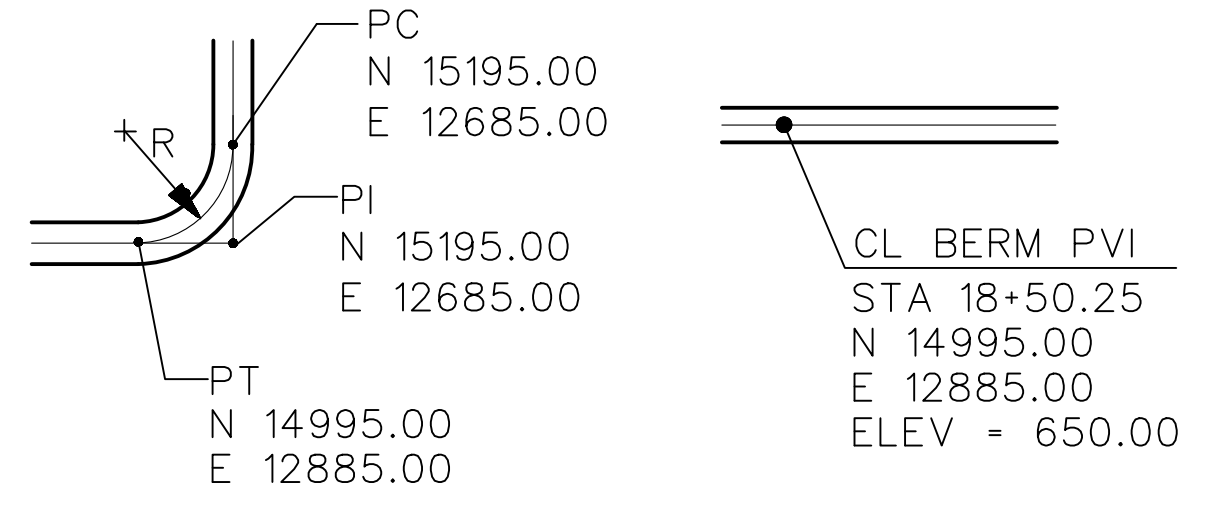
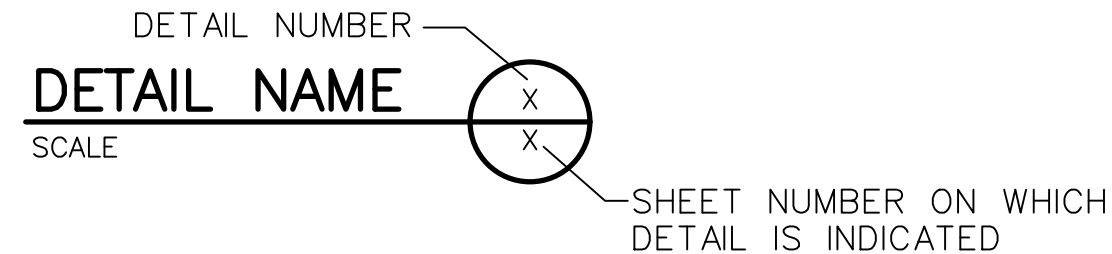

VERTICAL CONTROL DESIGNATION

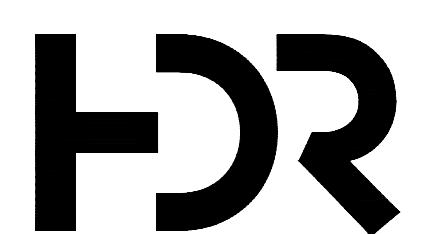
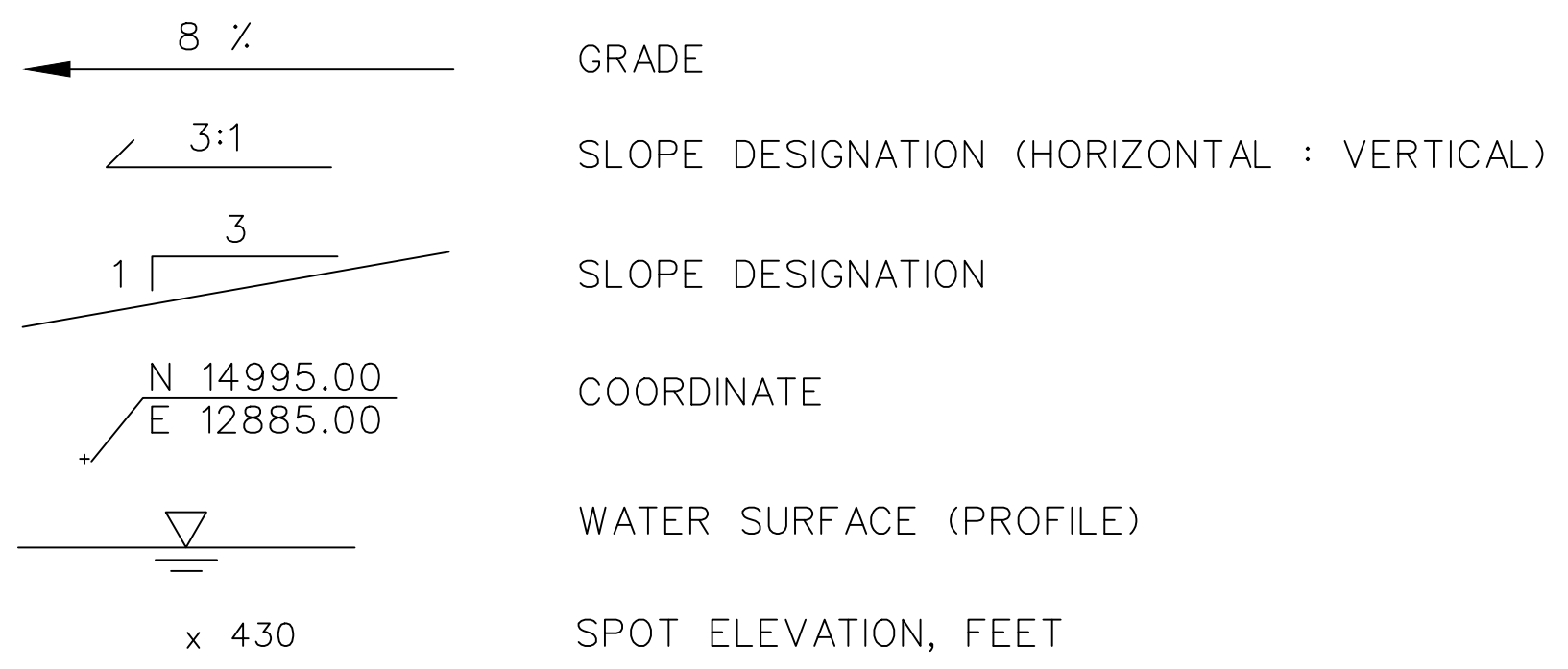

ISSUE	DATE	DESCRIPTION
A	01/31/2020	ISSUED FOR BID

PROJECT MANAGER	D. VOGT, P.E.
DESIGNED BY	K. PERERA
DRAWN BY	J. RAYMOND
CHECKED BY	M. ROBERTS
PROJECT NUMBER	10172630

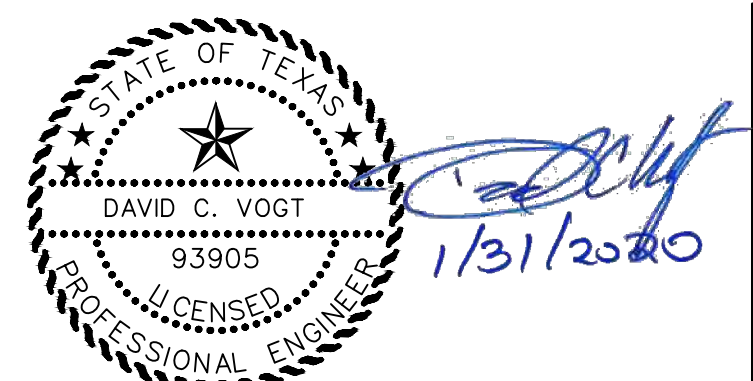

**MARTIN LAKE STEAM ELECTRICAL STATION
WEST ASH POND RELINE
RUSK COUNTY, TEXAS**



ABBREVIATIONS AND GENERAL NOTES

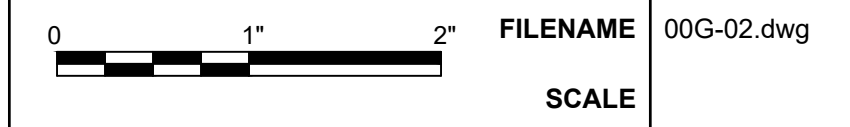

SHEET
00G-02

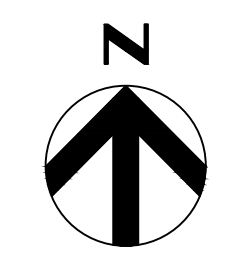

LEGEND
 ——— LIMITS OF CONSTRUCTION
 - - - - - LIMITS OF PDP 5

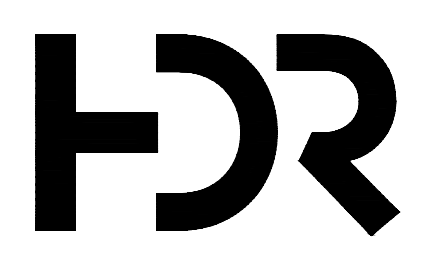
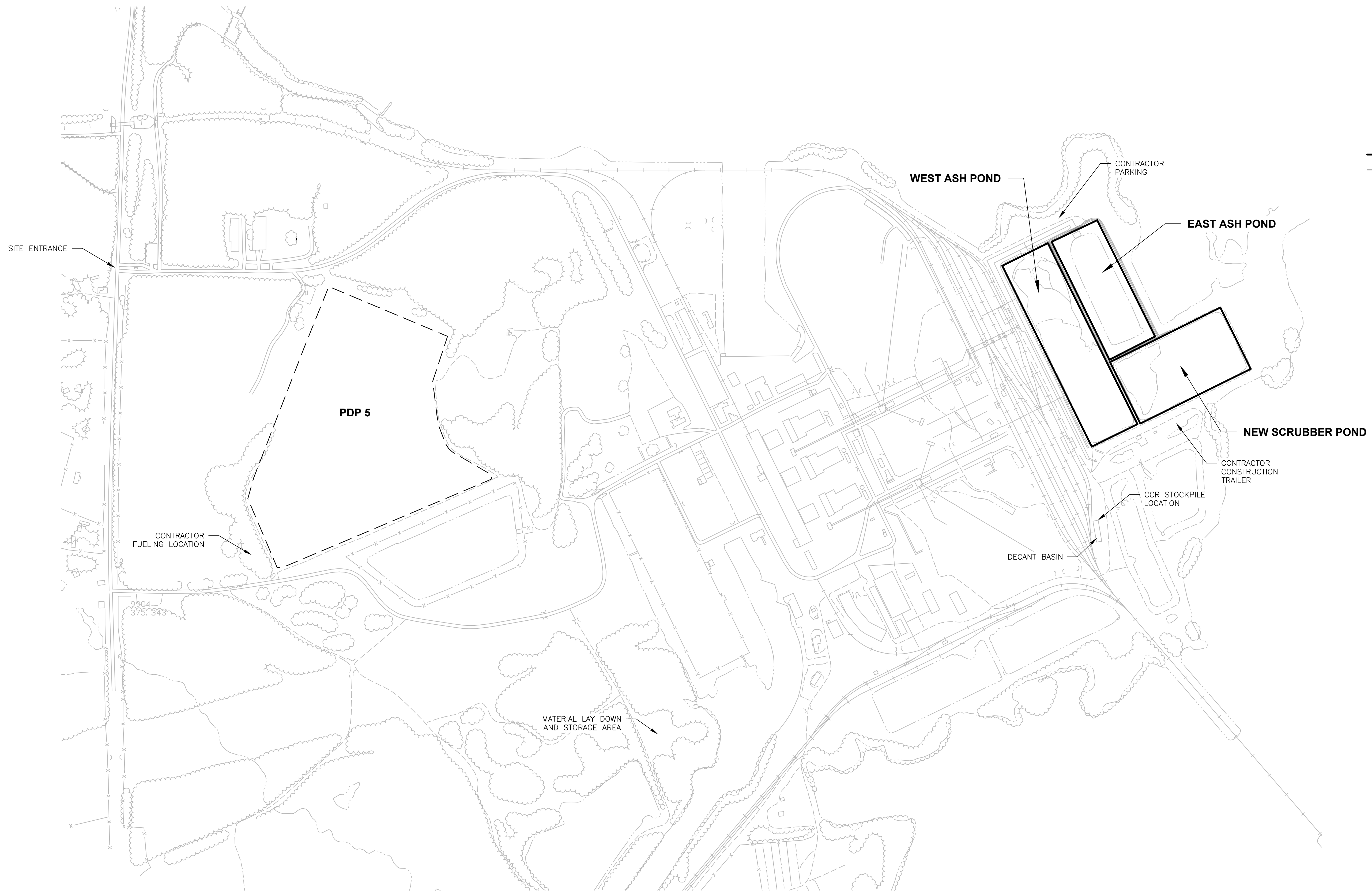

ISSUE	DATE	DESCRIPTION
A	01/31/2020	ISSUED FOR BID

PROJECT MANAGER	D. VOGT, P.E.
DESIGNED BY	K. PERERA
DRAWN BY	J. RAYMOND
CHECKED BY	M. ROBERTS
PROJECT NUMBER	10172630

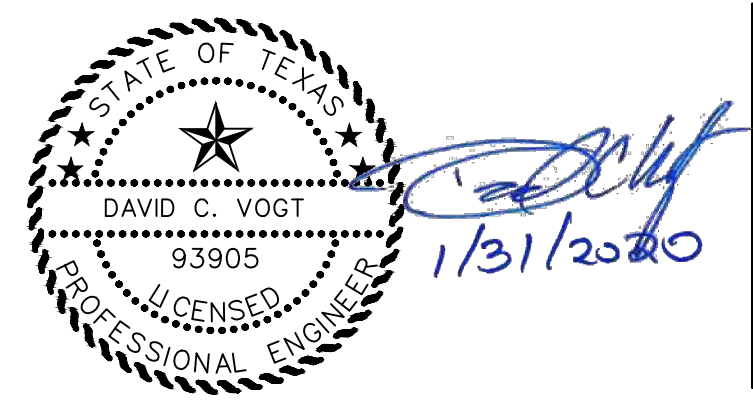

**MARTIN LAKE STEAM ELECTRICAL STATION
 WEST ASH POND RELINE
 RUSK COUNTY, TEXAS**

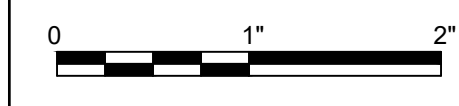

SITE LAYOUT

FILENAME | 00C-01.dwg
 SCALE | 1" = 400'

SHEET
00C-01

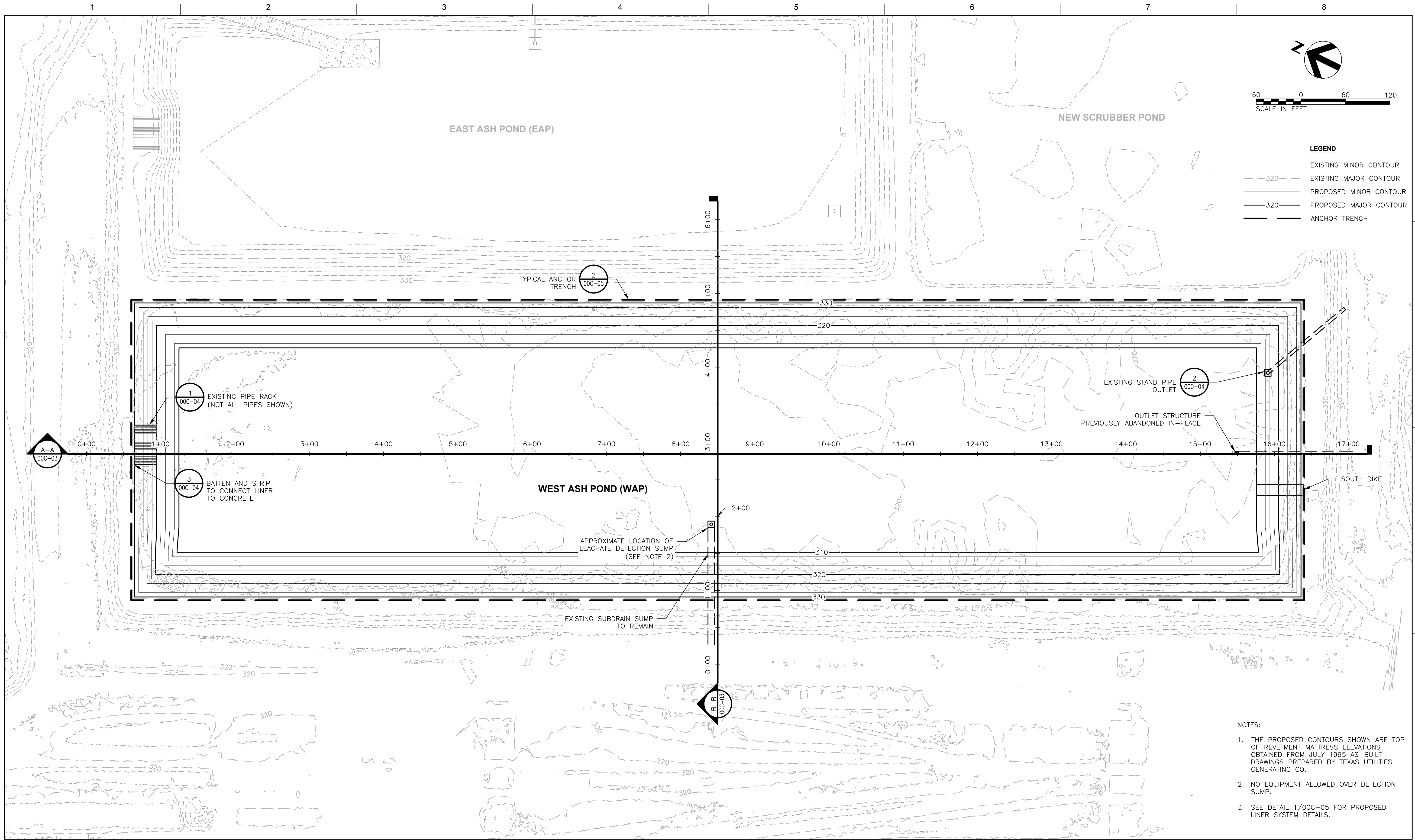

- LEGEND**
- - - - - EXISTING MINOR CONTOUR
 - - - 320 - - - EXISTING MAJOR CONTOUR
 - — — PROPOSED MINOR CONTOUR
 - — — 320 — — — PROPOSED MAJOR CONTOUR
 - — — ANCHOR TRENCH

- NOTES:**
1. THE PROPOSED CONTOURS SHOWN ARE TOP OF REVETMENT MATTRESS ELEVATIONS OBTAINED FROM JULY 1995 AS-BUILT DRAWINGS PREPARED BY TEXAS UTILITIES GENERATING CO.
 2. NO EQUIPMENT ALLOWED OVER DETECTION SUMP.
 3. SEE DETAIL 1/00C-05 FOR PROPOSED LINER SYSTEM DETAILS.

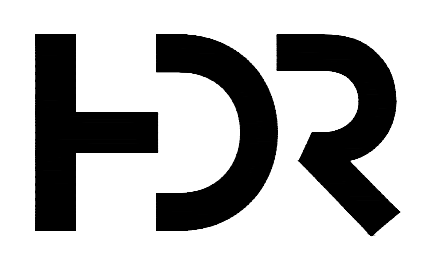

ISSUE	DATE	DESCRIPTION
A	01/31/2020	ISSUED FOR BID

PROJECT MANAGER	D. VOGT, P.E.
DESIGNED BY	K. PERERA
DRAWN BY	J. RAYMOND
CHECKED BY	M. ROBERTS
PROJECT NUMBER	10172630

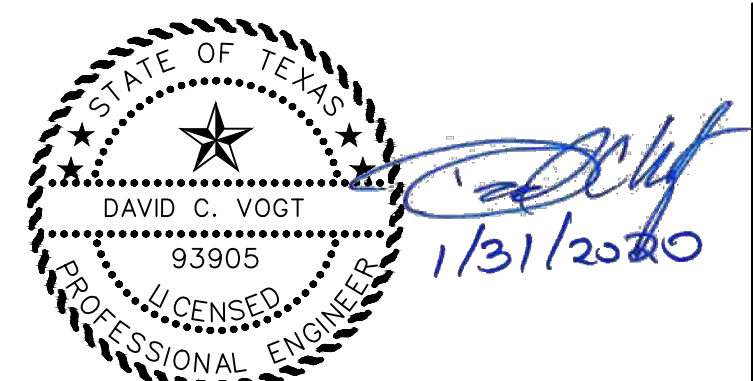

**MARTIN LAKE STEAM ELECTRICAL STATION
WEST ASH POND RELINE
RUSK COUNTY, TEXAS**



WEST ASH POND

0 1" 2"

FILENAME | 00C-02.dwg
SCALE | 1" = 60'

SHEET
00C-02

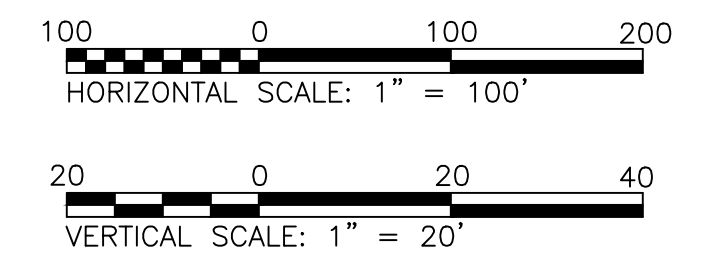

- LEGEND**
- TOP OF CCR MATERIAL
 - - - - - EXISTING GROUND SURFACE
 - PROPOSED GRADE

- NOTES:**
1. CCR ELEVATION FROM BATHYMETRIC SURVEY TAKEN FEBRUARY 2019 BY LACEY SURVEYING OF ARP, TEXAS. AT START OF PROJECT, OWNER WILL HAVE REMOVED BULK OF CCR MATERIAL FROM THE WEST ASH POND
 2. CONTRACTOR WILL REMOVE REMAINING CCR MATERIAL, ROCKS AND SEDIMENT WITHIN POND BEFORE INSTALLATION OF THE LINER SYSTEM.

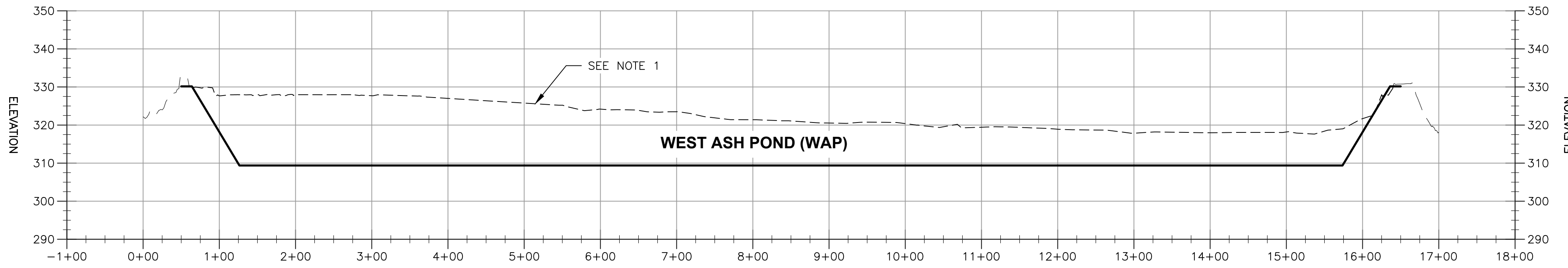

SECTION A-A
 HORIZONTAL SCALE: 1" = 100' ; VERTICAL SCALE: 1" = 20'

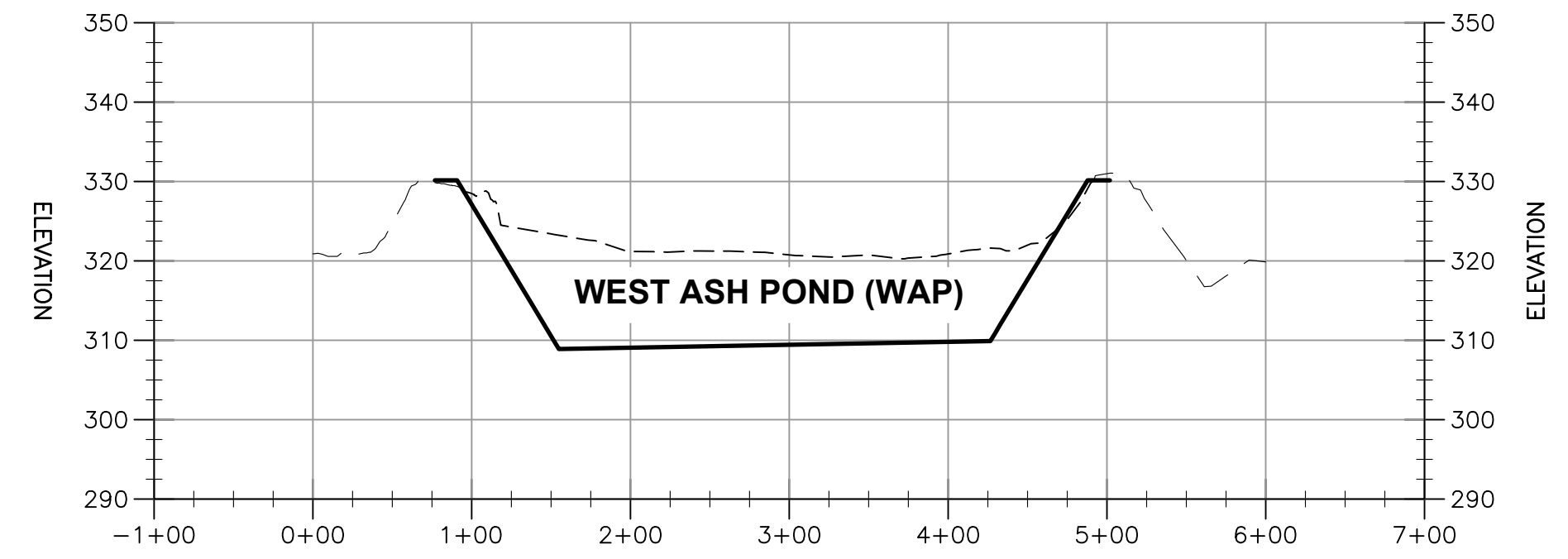

SECTION B-B
 HORIZONTAL SCALE: 1" = 100' ; VERTICAL SCALE: 1" = 20'

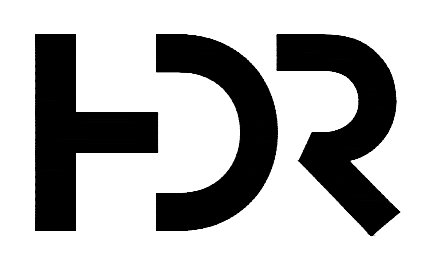

ISSUE	DATE	DESCRIPTION
A	01/31/2020	ISSUED FOR BID

PROJECT MANAGER	D. VOGT, P.E.
DESIGNED BY	K. PERERA
DRAWN BY	J. RAYMOND
CHECKED BY	M. ROBERTS
PROJECT NUMBER	10172630

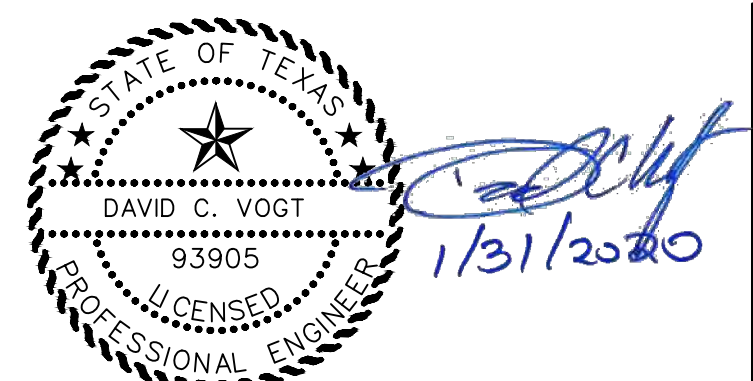

**MARTIN LAKE STEAM ELECTRICAL STATION
 WEST ASH POND RELINE
 RUSK COUNTY, TEXAS**



CROSS SECTIONS



FILENAME 00C-03.dwg
SCALE H: 1" = 100' ; V: 1" = 20'

SHEET
00C-03

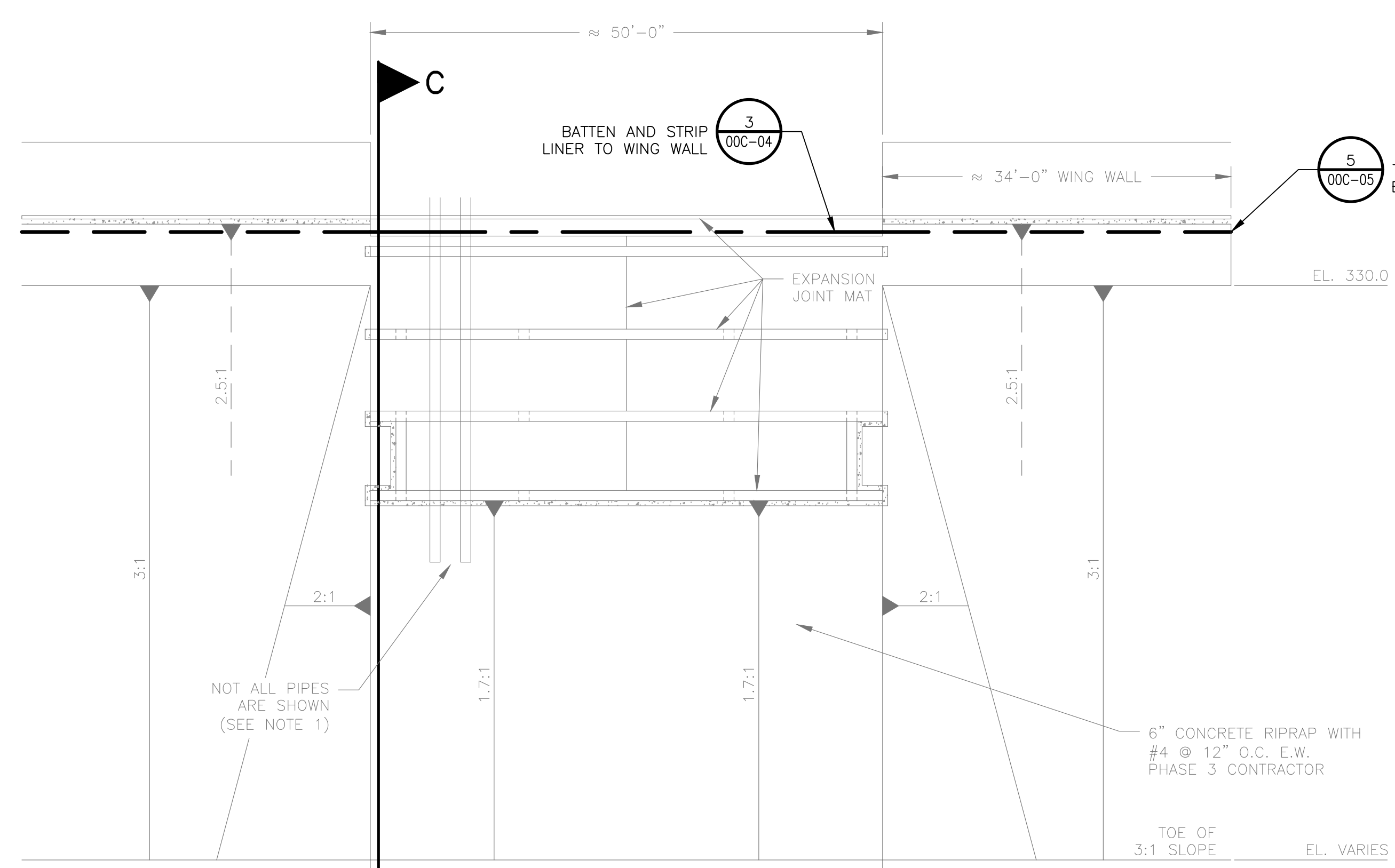

TYPICAL PIPE RACK
NOT TO SCALE

NOTES:
1. EXISTING INLET PIPES SHALL BE CUT TO INSTALL LINER. UPON INSTALLATION OF THE LINER, PIPES SHALL BE REINSTALLED.

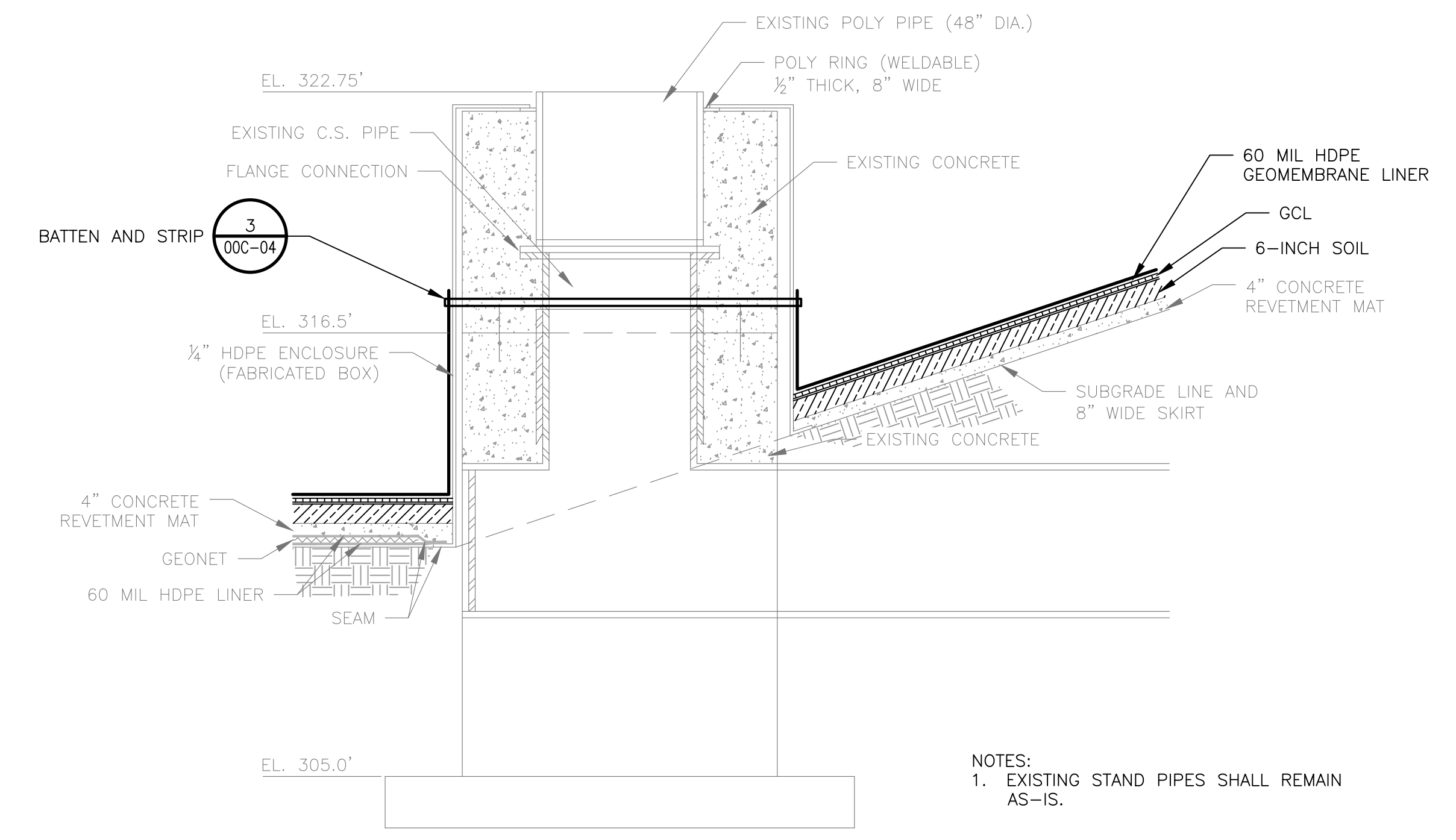

STANDPIPE ENCLOSURE
NOT TO SCALE

NOTES:
1. EXISTING STAND PIPES SHALL REMAIN AS-IS.

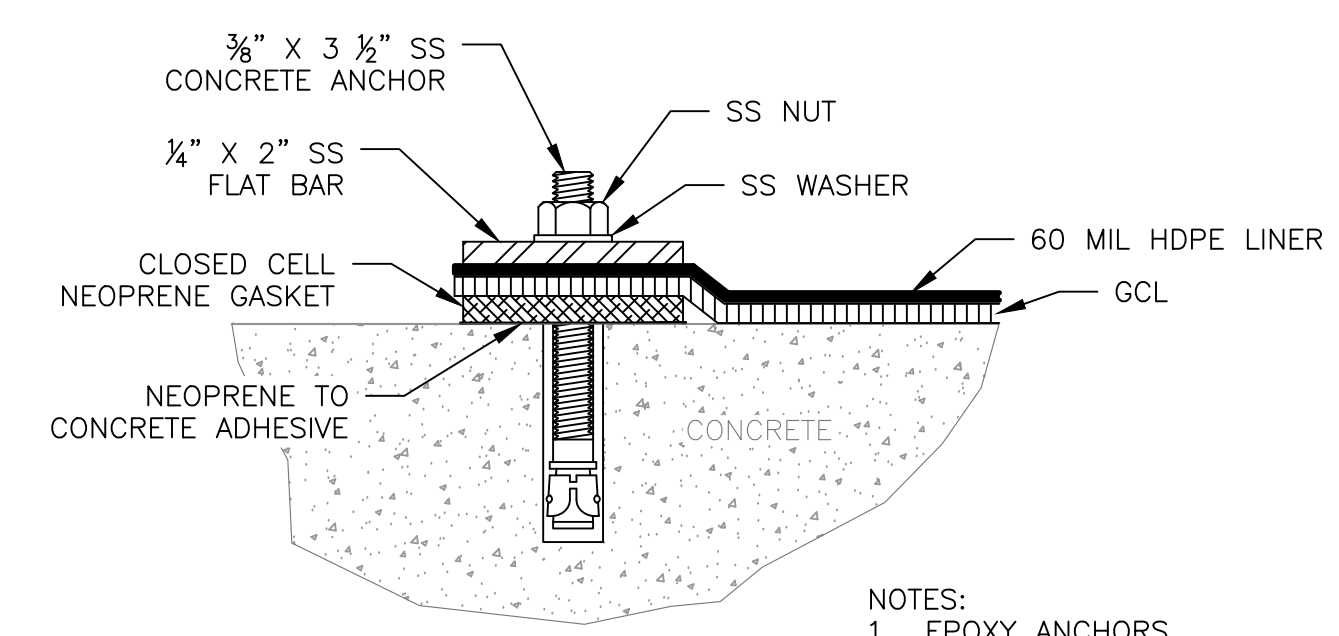

BATTEN AND STRIP CONNECTION AT ANCHOR TRENCH
NOT TO SCALE

NOTES:
1. EPOXY ANCHORS SPACED AT 6" O.C.

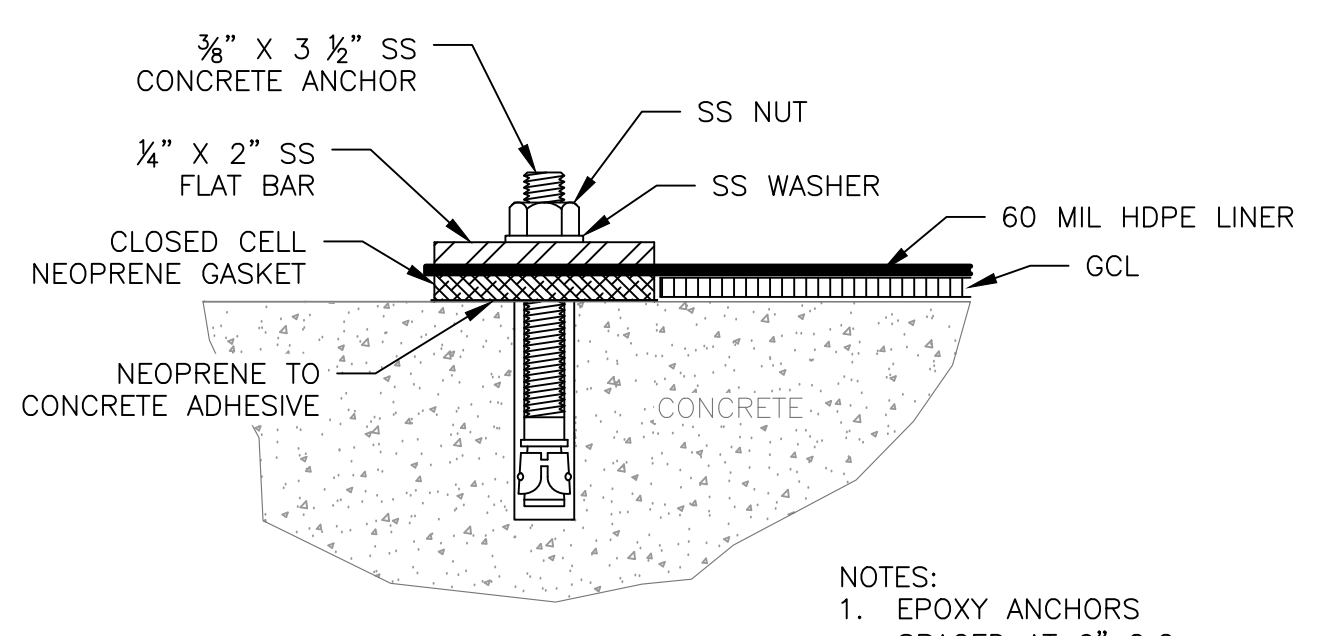

BATTEN AND STRIP CONNECTION BELOW WATER SURFACE
NOT TO SCALE

NOTES:
1. EPOXY ANCHORS SPACED AT 6" O.C.

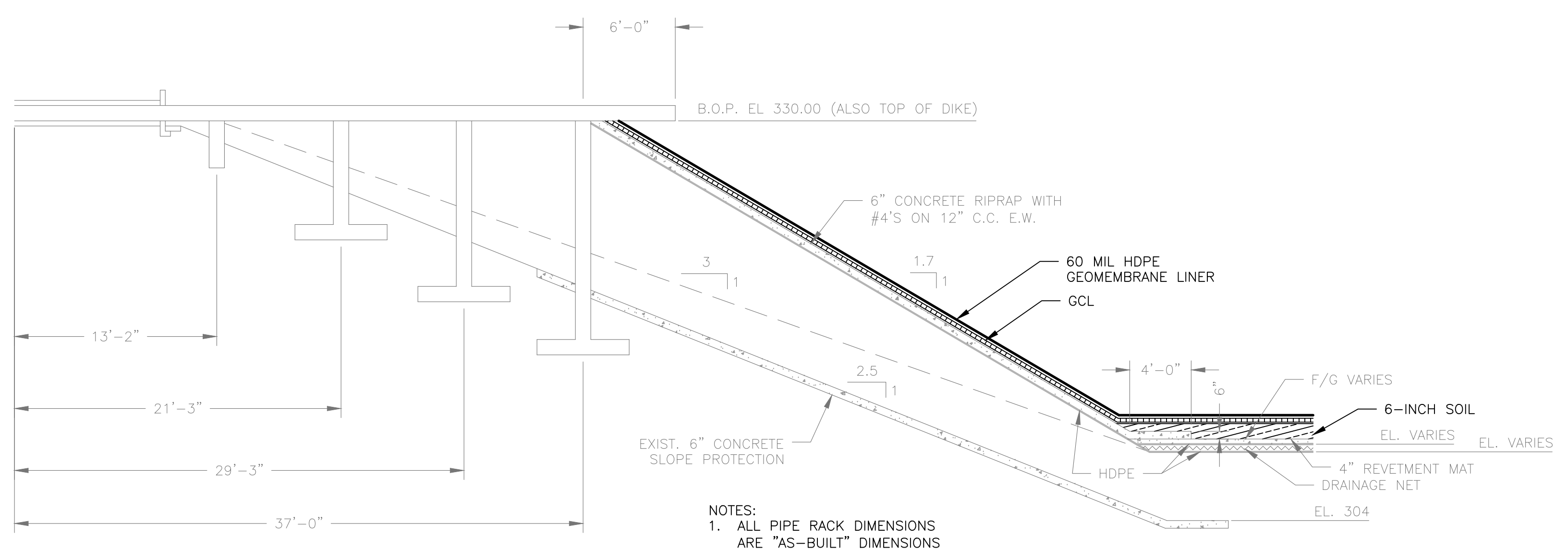

SECTION C-C
NOT TO SCALE

NOTES:
1. ALL PIPE RACK DIMENSIONS ARE "AS-BUILT" DIMENSIONS FOR EAST ASH POND.

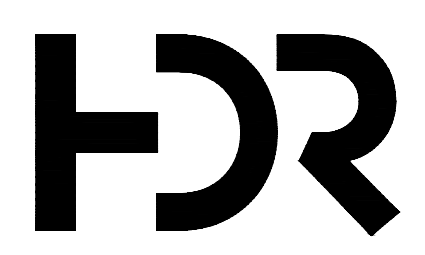

ISSUE	DATE	DESCRIPTION
A	01/31/2020	ISSUED FOR BID

PROJECT MANAGER	D. VOGT, P.E.
DESIGNED BY	K. PERERA
DRAWN BY	J. RAYMOND
CHECKED BY	M. ROBERTS
PROJECT NUMBER	10172630

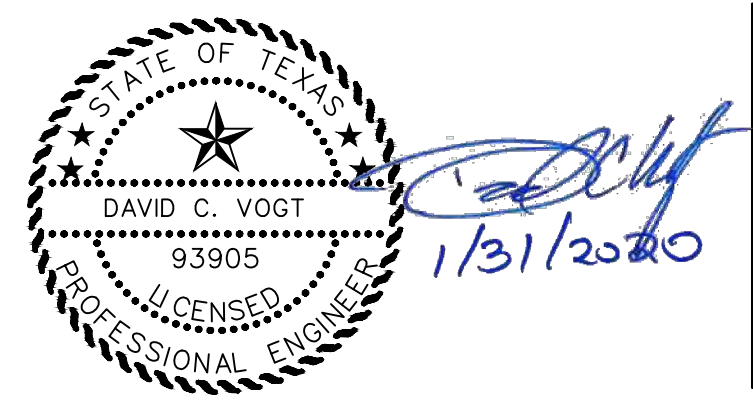

**MARTIN LAKE STEAM ELECTRICAL STATION
WEST ASH POND RELINE
RUSK COUNTY, TEXAS**

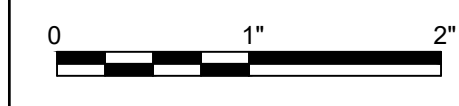

**DETAILS
(1 OF 2)**

FILENAME | 00C-04.dwg
SCALE

SHEET
00C-04

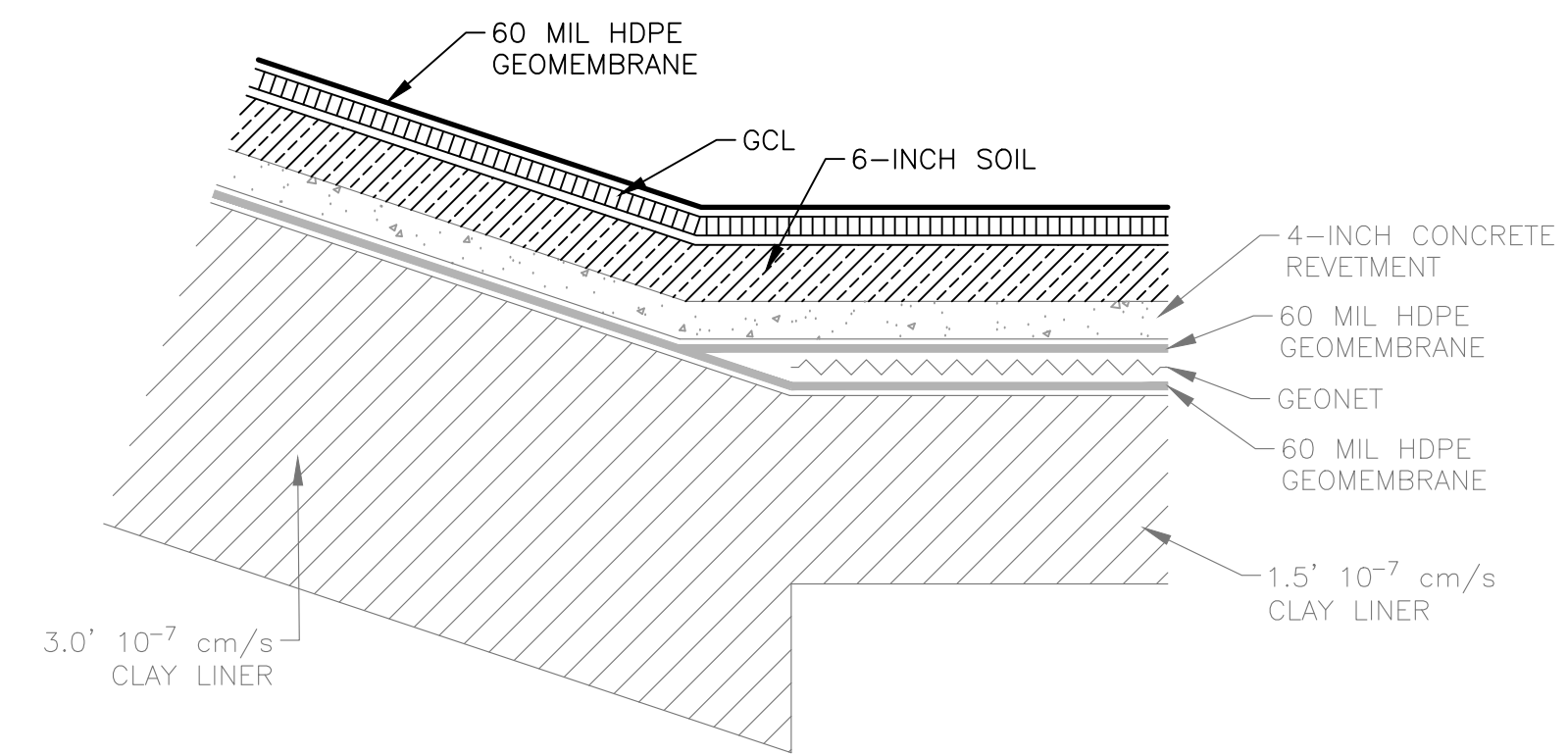

PROPOSED WAP SECTION 1
NOT TO SCALE

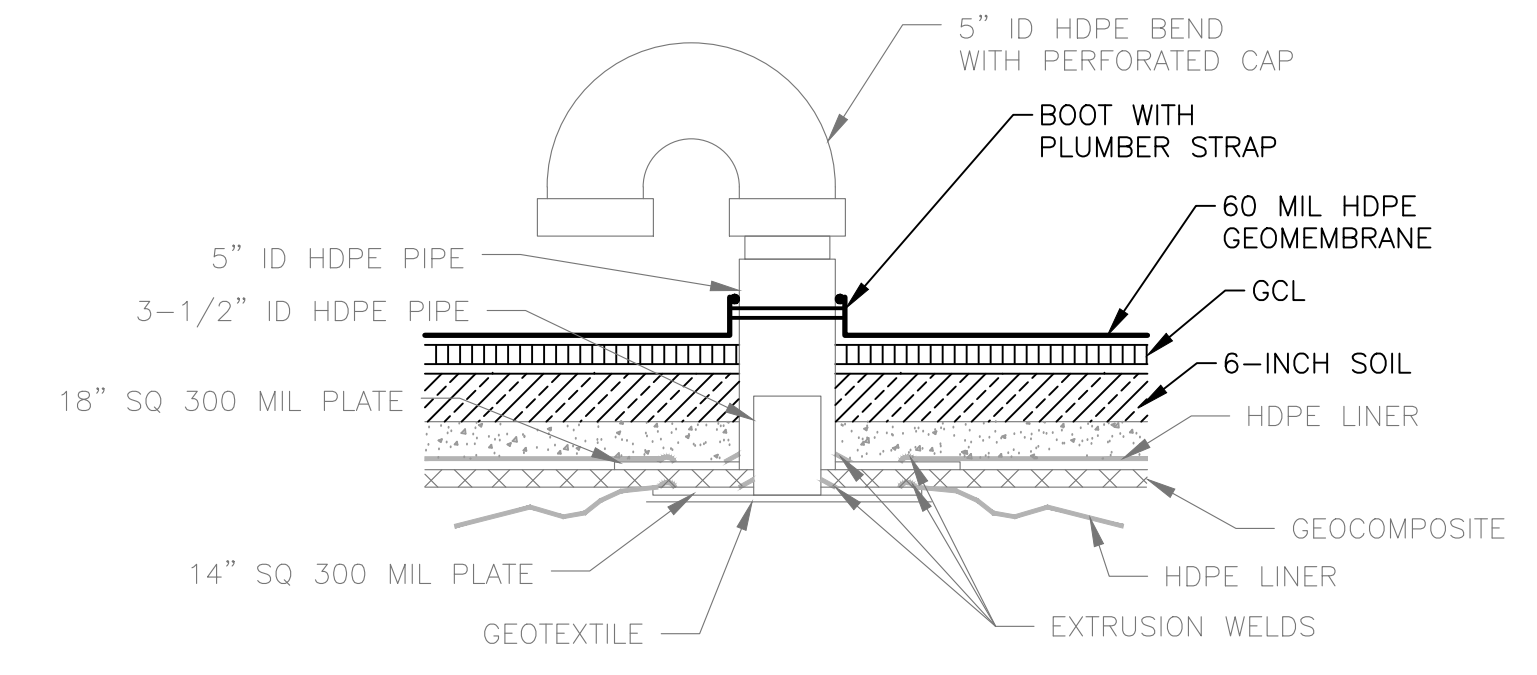

TYPICAL AIR-GAS VENT 3
NOT TO SCALE

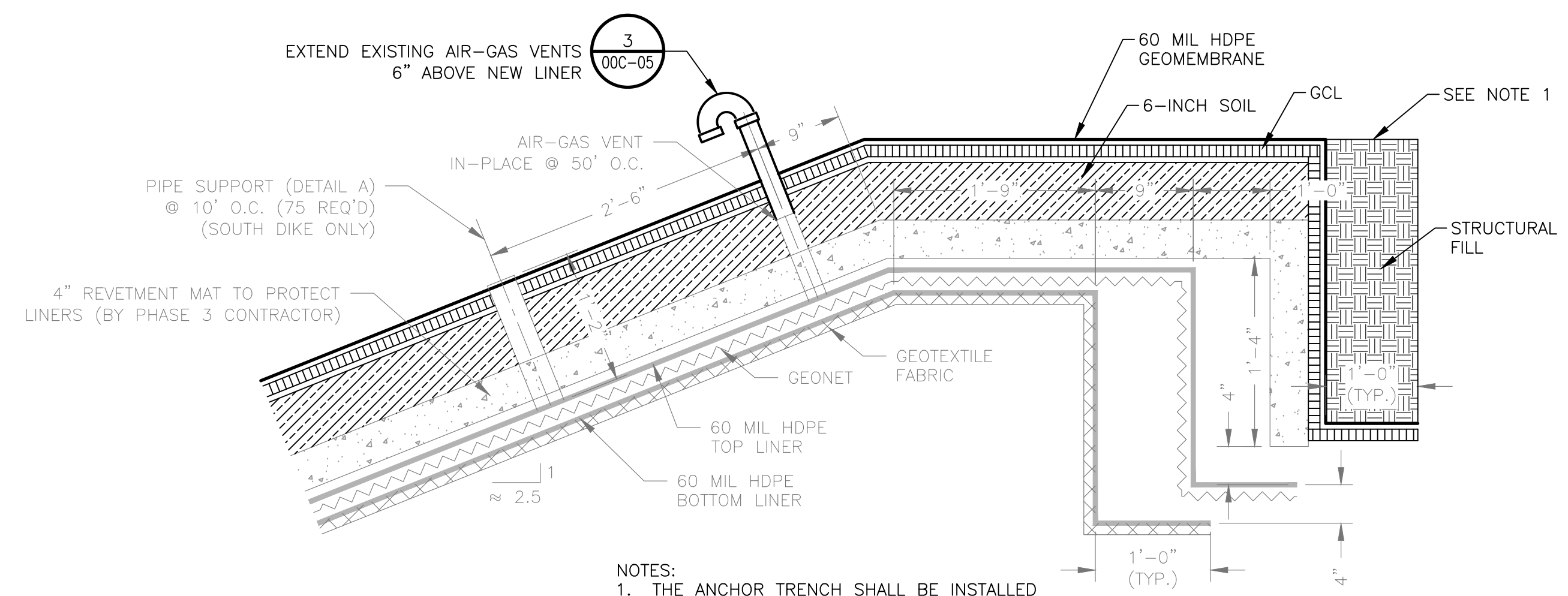

NOTES:
1. THE ANCHOR TRENCH SHALL BE INSTALLED OUTSIDE OF THE EXISTING ANCHOR TRENCH.

ANCHOR TRENCH 2
NOT TO SCALE

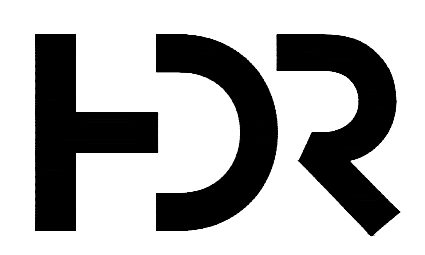

ISSUE	DATE	DESCRIPTION
A	01/31/2020	ISSUED FOR BID

PROJECT MANAGER	D. VOGT, P.E.
DESIGNED BY	K. PERERA
DRAWN BY	J. RAYMOND
CHECKED BY	M. ROBERTS
PROJECT NUMBER	10172630

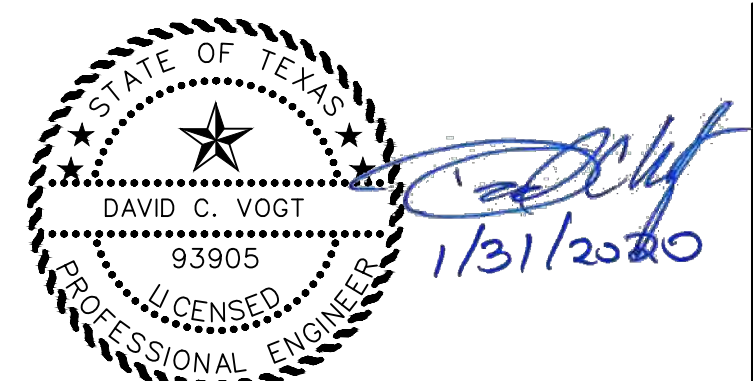

**MARTIN LAKE STEAM ELECTRICAL STATION
WEST ASH POND RELINE
RUSK COUNTY, TEXAS**



**DETAILS
(2 OF 2)**

FILENAME | 00C-05.dwg
SCALE | NOT TO SCALE

SHEET
00C-05



N

600 0 600 1200
SCALE IN FEET

LEGEND

- LIMITS OF CONSTRUCTION
- - - LIMITS OF PDP 5
- HAUL ROUTE

D
C
B
A

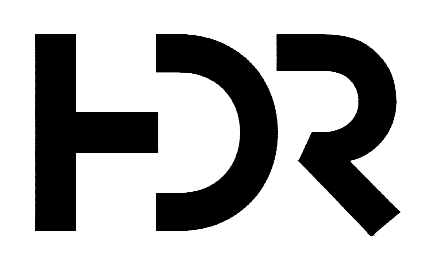

ISSUE	DATE	DESCRIPTION
A	01/31/2020	ISSUED FOR BID

PROJECT MANAGER	D. VOGT, P.E.
DESIGNED BY	K. PERERA
DRAWN BY	J. RAYMOND
CHECKED BY	M. ROBERTS
PROJECT NUMBER	10172630

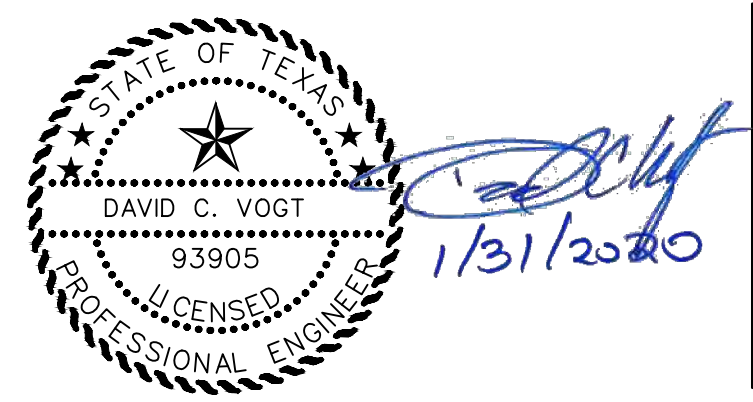

**MARTIN LAKE STEAM ELECTRICAL STATION
WEST ASH POND RELINE
RUSK COUNTY, TEXAS**



STOCKPILE AND HAUL ROUTE

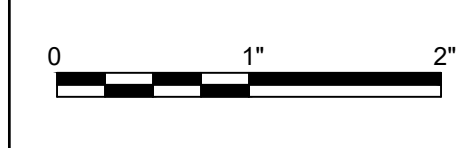

FILENAME | 00C-06.dwg
SCALE | 1" = 600'

SHEET
00C-06

APPENDIX E – NEW SCRUBBER POND RETROFIT DESIGN DRAWINGS

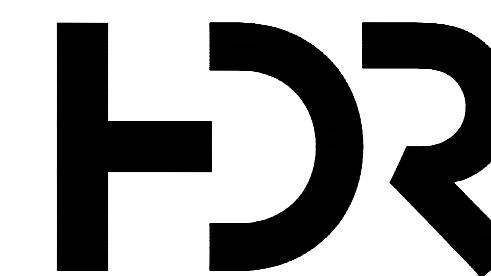

HDR ENGINEERING, INC.
76 SOUTH LAURA STREET, SUITE 1600
JACKSONVILLE, FL 32202
COA# 4213



Construction Drawings For

Martin Lake Steam Electric Station

CCR Impoundment Reline New Scrubber Pond

Project No.
10172630

Rusk County, Texas
January 2020

INDEX OF DRAWINGS

GENERAL	
00G-01	COVER SHEET
00G-02	ABBREVIATIONS AND GENERAL NOTES
CIVIL	
00C-01	SITE LAYOUT
00C-02	NEW SCRUBBER POND
00C-03	ROSS SECTIONS
00C-04	DETAILS (1 OF 2)
00C-05	DETAILS (2 OF 2)
00C-06	STOCKPILE AND HAUL ROUTE



VICINITY MAP
NOT TO SCALE

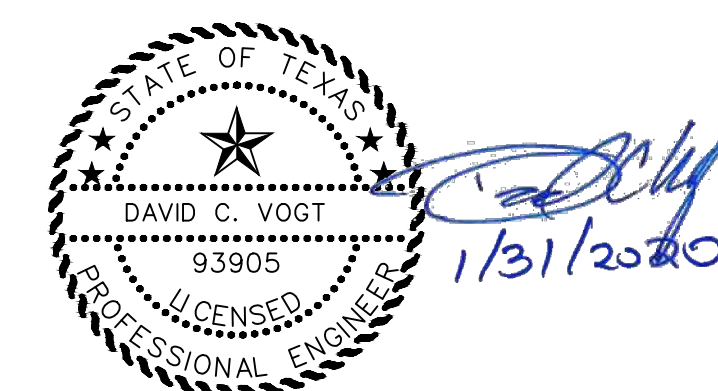

STANDARD ABBREVIATIONS

Table listing abbreviations such as APPROX, BOL, CL, CMP, CO, CY, DIA, DET, DWG, E, EAP, ELEV, EW, EXIST, EXC, FGD, FML, FT, GAL, GND, GDL, GNDL, HDPE, HORIZ, ID, IN, IE, LCRS, LCS, LCP, LCPR, LF, LB, MH, MAX, MIL, MIN, MW, MLES, MSL, N, NIC, NO.

Table listing abbreviations such as NTS, NTYS, OC, OZ, PLCP, PERF, PGL, PDP, PC, PI, PVI, PT, PZ, Q, QTY, R, RCP, REF, REQ, RD, SCH, SDL, SEC, SHT, S, SDR, SLQCP, SP, SQ, SS, STA, STYS, T.A.S., TL, TOC, TOFC, TOL, TOS, TS, TEMP, TYP, UNO, VERT, W, W/, WAP, WW, YD.

CONSTRUCTION SEQUENCE

- A. CONTRACTOR SHALL CLEAN THE NSP BY REMOVING ANY REMAINING CCR MATERIAL, ROCKS, AND SEDIMENT.
B. CONTRACTOR SHALL USE WATER FROM THE ADJACENT WEST ASH POND (WAP) OR EAST ASH POND (EAP) TO WASH REMAINING CCR MATERIAL OFF THE SIDES AND FLOOR OF THE NSP AND REMOVE IT.
C. CONTRACTOR SHALL LOAD AND HAUL GENERAL SOIL FILL MATERIAL FROM THE OWNER'S STOCKPILE...
D. CONTRACTOR SHALL PLACE THE GENERAL FILL MATERIAL OVER THE EXISTING CONCRETE REVDMENT...
E. CONTRACTOR SHALL INSTALL A GEOSYNTHETIC CLAY LINER (GCL) OVER THE SIDES AND FLOOR OF THE NSP...
F. CONTRACTOR SHALL INSTALL A 60-MIL HDPE LINER DIRECTLY ON THE GCL...

GENERAL NOTES

- 1. ALL WORK UNDER THIS CONTRACT SHALL BE PERFORMED IN ACCORDANCE WITH THE PLANS AND PROJECT SPECIFICATIONS...
2. COORDINATE SYSTEM IS BASED ON LOCAL SURVEY...
3. THE CONTRACTOR SHALL VERIFY EXISTING CONTOURS PRIOR TO THE START OF WORK...
4. THERE SHALL NOT BE ANY ADDITIONAL PAYMENT OR EXTENSION OF CONTRACT TIME...
5. THE CONTRACTOR SHALL TAKE ALL NECESSARY PRECAUTIONS TO PROTECT EXISTING ROADS...
6. THE LOCATIONS OF EXISTING UNDERGROUND UTILITIES HAVE NOT BEEN ESTABLISHED...
7. EXCAVATION BY "BLASTING" IS NOT PERMITTED ON THIS PROJECT...
8. FINISHED GROUND ELEVATIONS SHALL MATCH EXISTING GROUND ELEVATIONS...
9. GEOTECHNICAL INVESTIGATION REPORTS FOR THE SITE ARE AVAILABLE FOR REVIEW...
10. THE CONTRACTOR SHALL CONSTRUCT AND UPON COMPLETION OF THE PROJECT...
11. THE CONTRACTOR SHALL INSTALL, MAINTAIN, AND UPON COMPLETION OF THE PROJECT...
12. TEMPORARY CONSTRUCTION SLOPES SHALL NOT BE GREATER THAN 2H:1V...
13. THE CONTRACTOR SHALL REMOVE ALL VEGETATION WITHIN THE CONSTRUCTION LIMITS...
14. THE CONTRACTOR SHALL OBTAIN AND CONDUCT WORK CONSISTENT WITH A TPDES PERMIT...
15. THE CONTRACTOR SHALL IMMEDIATELY REPORT TO THE ENGINEER ANY ERROR OR DISCREPANCY...
16. THE DRAWINGS AND SPECIFICATIONS SHOULD AGREE WITH EACH OTHER...
17. CONTRACTOR AND EACH SUBCONTRACTOR SHALL VERIFY ALL GRADES, LINES, LEVELS...
18. CONTRACTOR SHALL PROVIDE EROSION CONTROL BY SEEDING FOR ALL AREAS...
19. CONTRACTOR SHALL INSTALL EROSION AND SEDIMENT CONTROLS...
20. STORMWATER THAT HAS COME INTO CONTACT WITH THE ASH WITHIN THE EXCAVATED POND...
21. THE CONTRACTOR IS REQUIRED TO PRESENT THE SWPPP TO LUMINANT ENVIRONMENTAL SERVICES...
22. THE CONTRACTOR IS REQUIRED TO SUBMIT THE NOTICE OF INTENT AND NOTICE OF TERMINATION...
23. THE CONTRACTOR IS TO ACQUIRE A DIGGING PERMIT FROM THE PLANT BEFORE COMMENCING ANY EXCAVATION ACTIVITY.

SYMBOLS

SECTION DETAIL INDICATORS

DRAWING ON WHICH SECTION IS CUT:

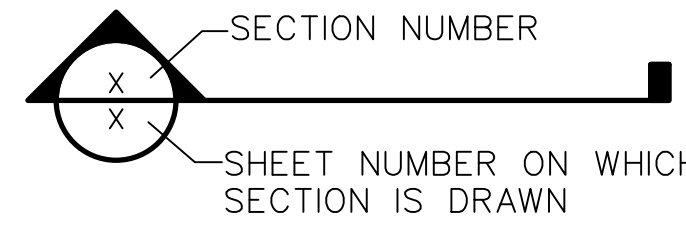

DRAWING ON WHICH SECTION APPEARS:

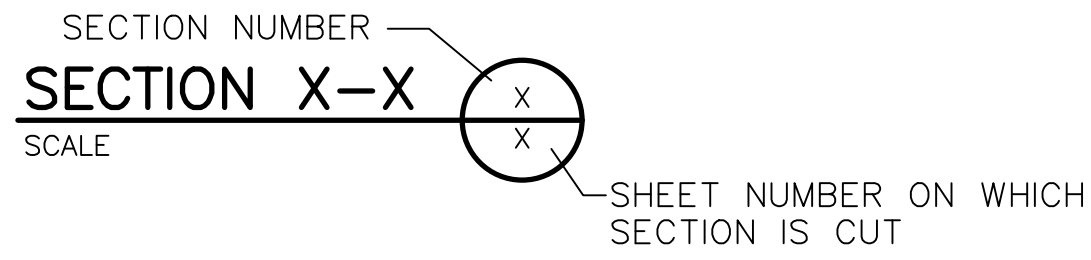

DRAWING ON WHICH DETAIL IS INDICATED:

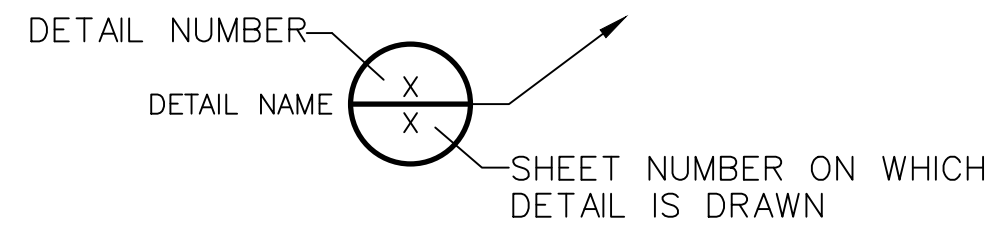

DRAWING ON WHICH DETAIL APPEARS:

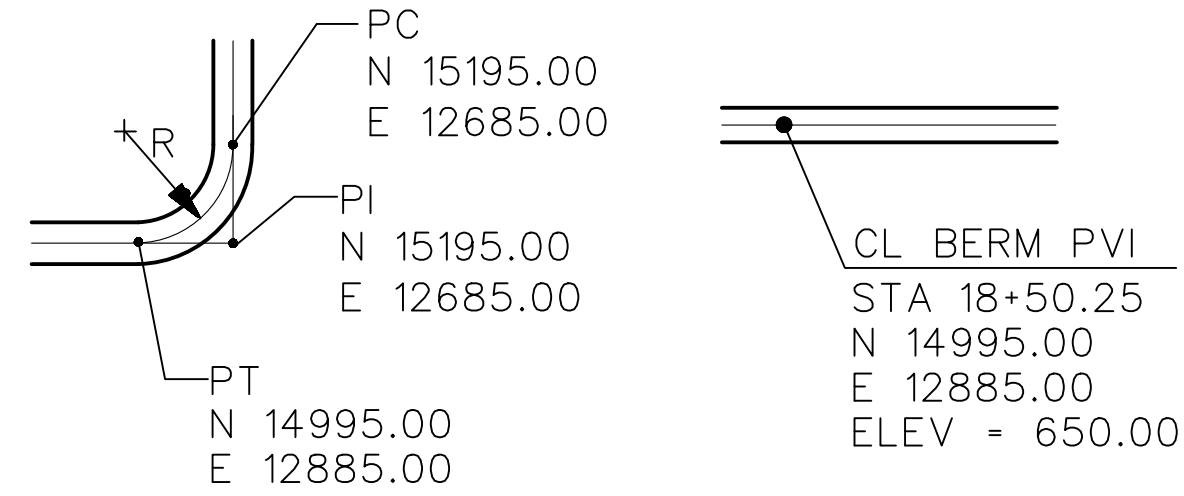
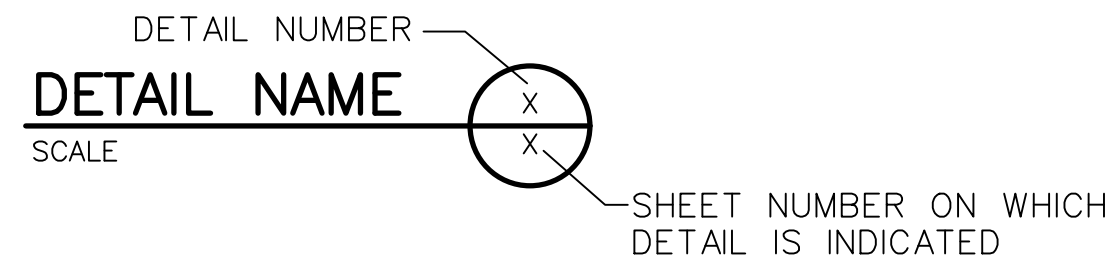

CURVE WITH HORIZONTAL CONTROL:

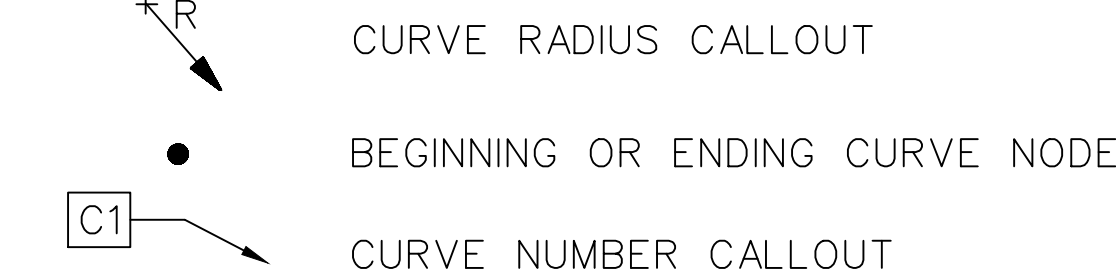

VERTICAL CONTROL DESIGNATION

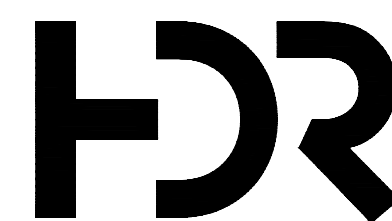
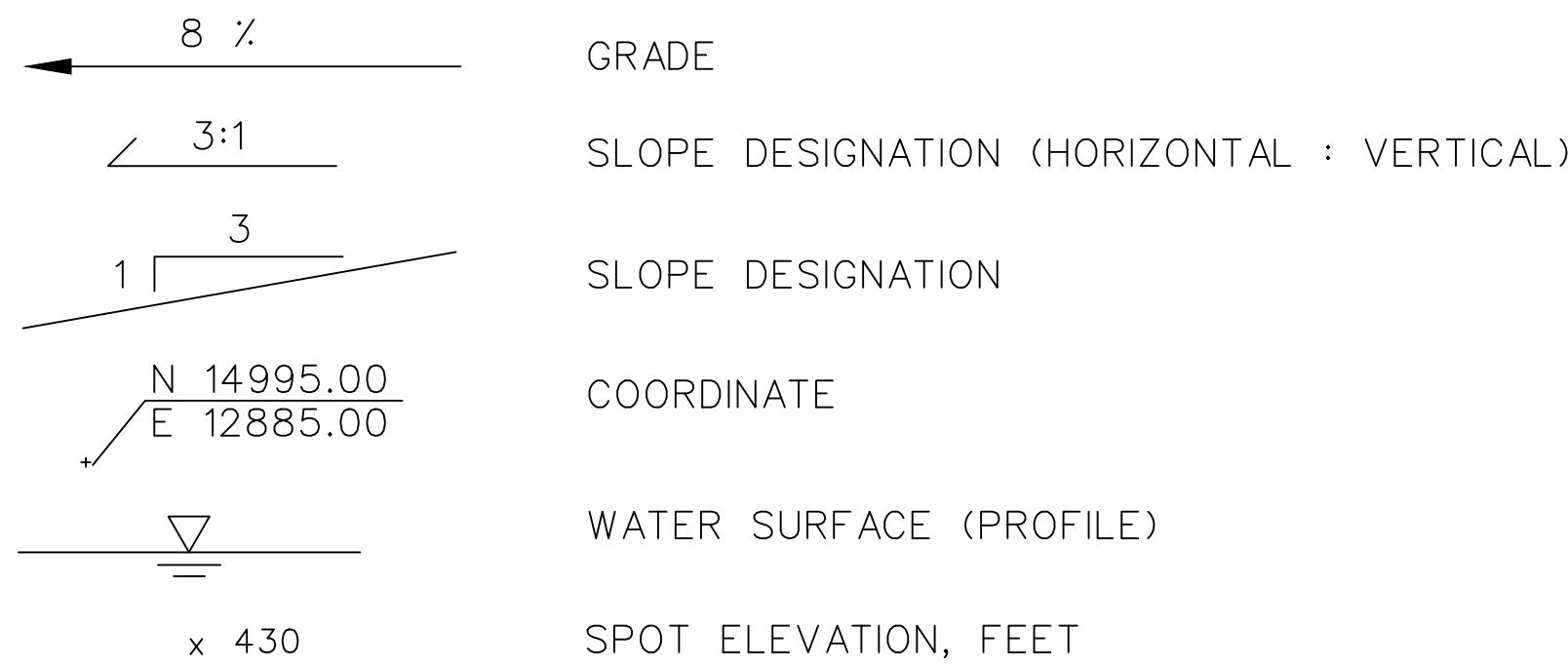
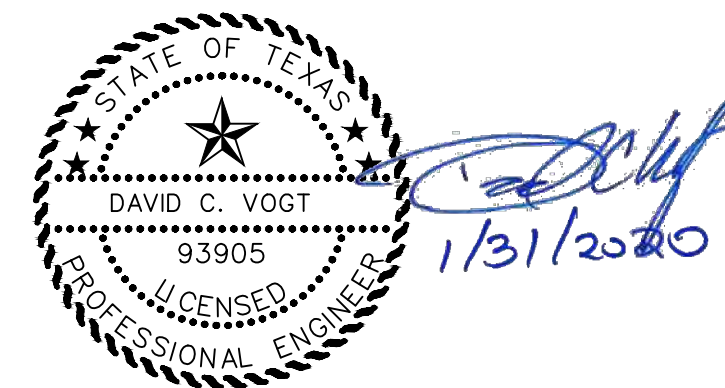

Table with columns: ISSUE, DATE, DESCRIPTION. Row 1: A, 01/31/2020, ISSUED FOR BID.

Table with columns: PROJECT MANAGER, DESIGNED BY, DRAWN BY, CHECKED BY, PROJECT NUMBER. Values: D. VOGT, P.E.; K. PERERA; J. RAYMOND; M. ROBERTS; 10172630.



MARTIN LAKE STEAM ELECTRICAL STATION
NEW SCRUBBER POND RELINE
RUSK COUNTY, TEXAS



ABBREVIATIONS AND GENERAL NOTES

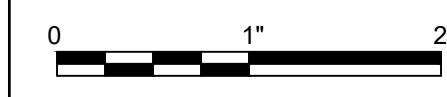

FILENAME | 00G-02.dwg
SCALE

SHEET | 00G-02

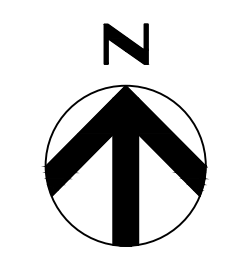

LEGEND
 ——— LIMITS OF CONSTRUCTION
 - - - - - LIMITS OF PDP 5

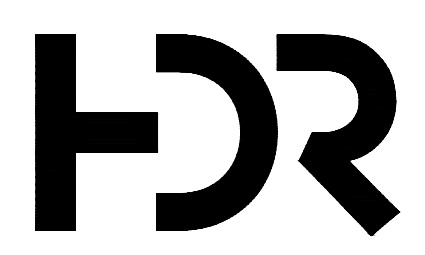
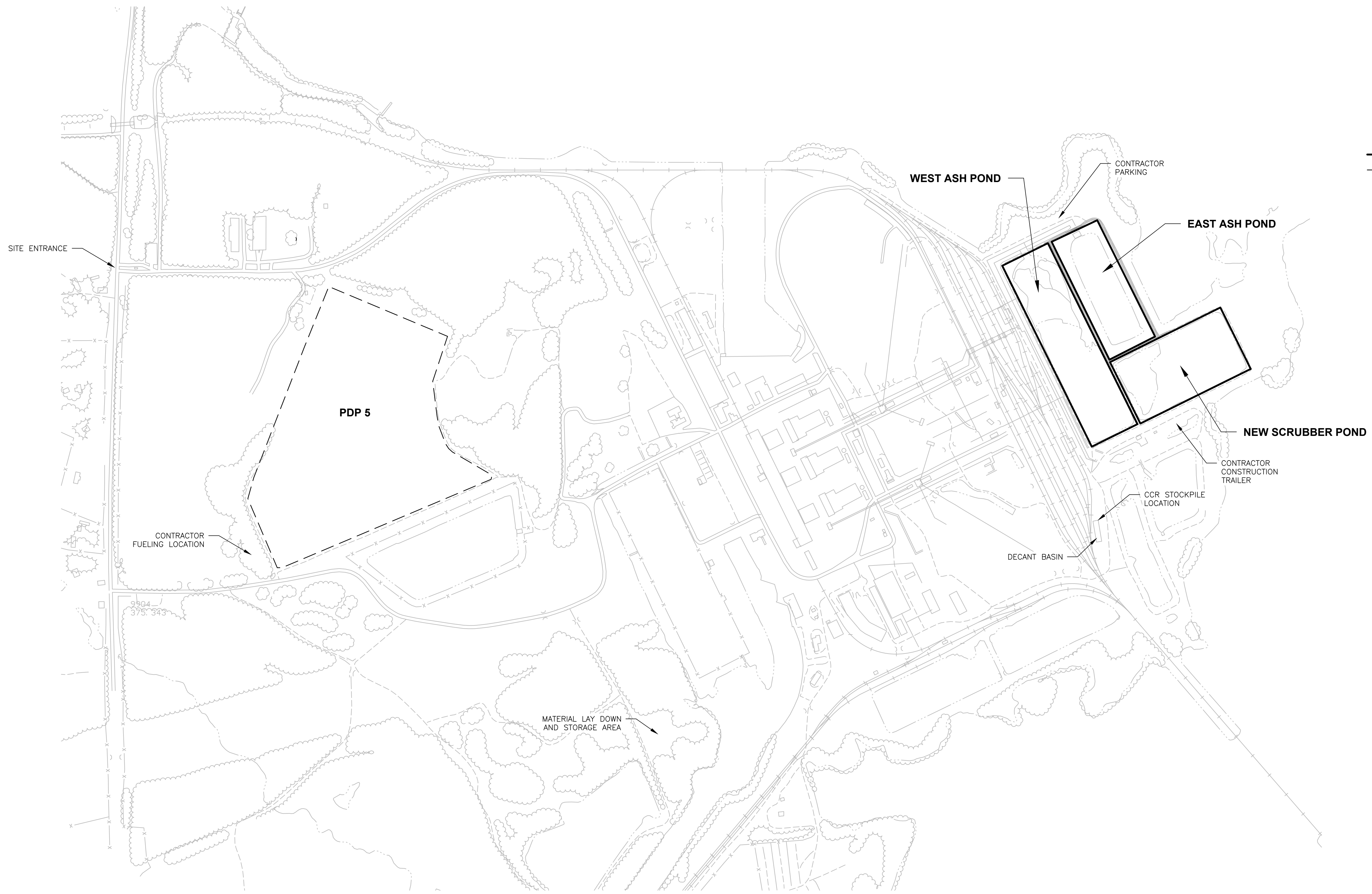

ISSUE	DATE	DESCRIPTION
A	01/31/2020	ISSUED FOR BID

PROJECT MANAGER	D. VOGT, P.E.
DESIGNED BY	K. PERERA
DRAWN BY	J. RAYMOND
CHECKED BY	M. ROBERTS
PROJECT NUMBER	10172630

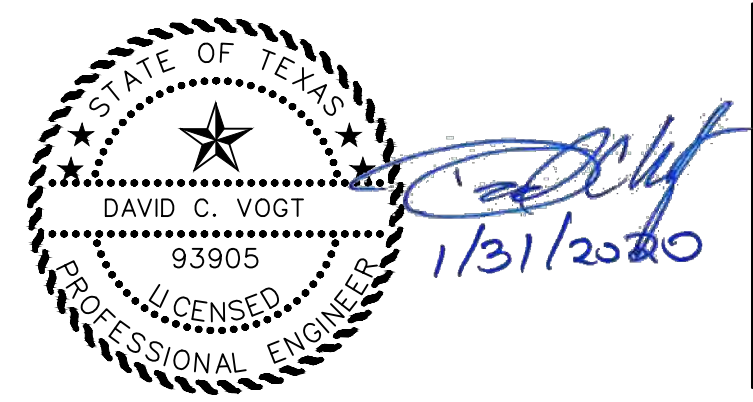

**MARTIN LAKE STEAM ELECTRICAL STATION
 NEW SCRUBBER POND RELINE
 RUSK COUNTY, TEXAS**

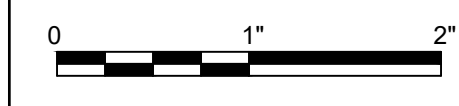

SITE LAYOUT

FILENAME | 00C-01.dwg
 SCALE | 1" = 400'

SHEET
00C-01

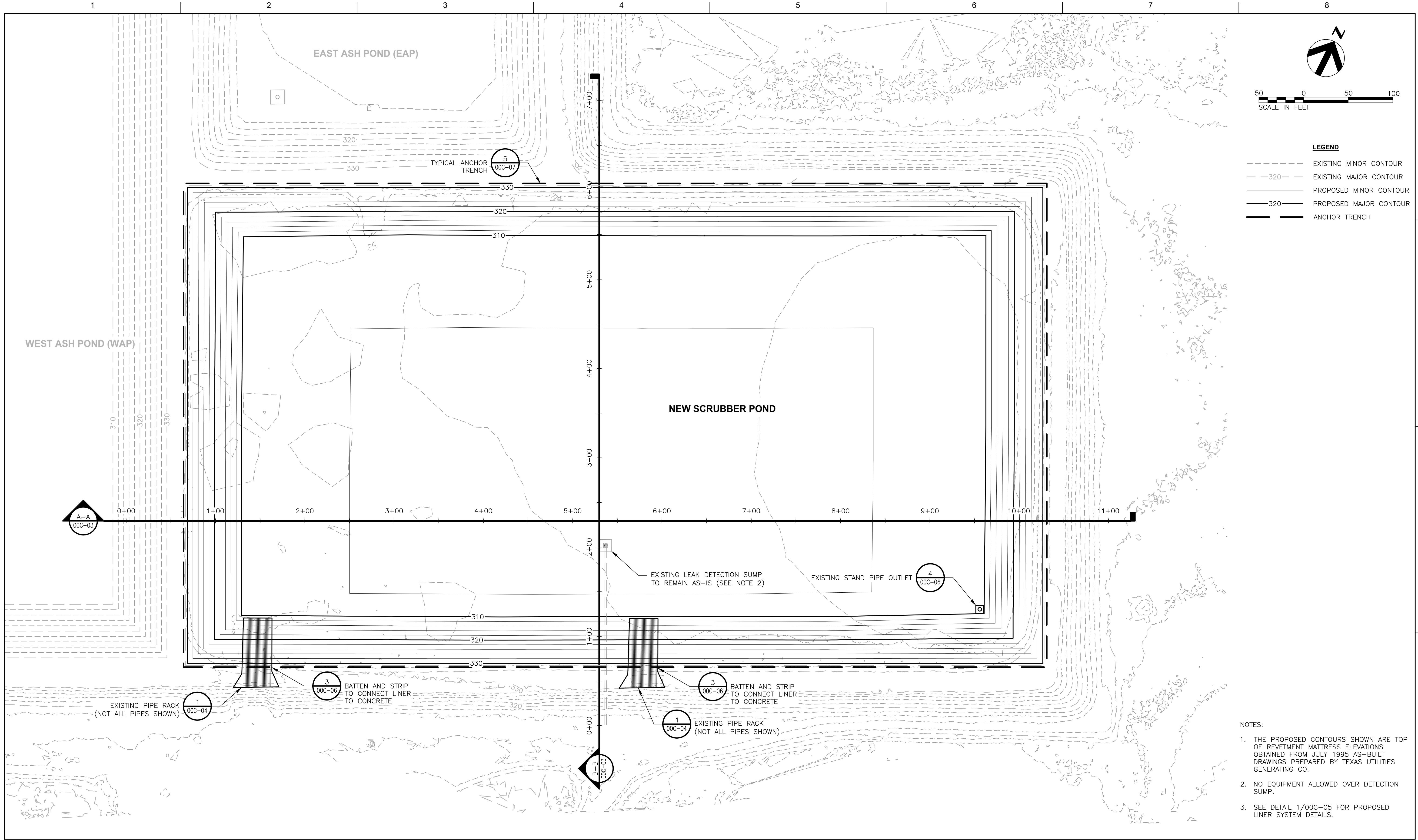

- LEGEND**
- EXISTING MINOR CONTOUR
 - - - - - EXISTING MAJOR CONTOUR
 - PROPOSED MINOR CONTOUR
 - 320 — PROPOSED MAJOR CONTOUR
 - — — — — ANCHOR TRENCH

- NOTES:**
1. THE PROPOSED CONTOURS SHOWN ARE TOP OF REVETMENT MATTRESS ELEVATIONS OBTAINED FROM JULY 1995 AS-BUILT DRAWINGS PREPARED BY TEXAS UTILITIES GENERATING CO.
 2. NO EQUIPMENT ALLOWED OVER DETECTION SUMP.
 3. SEE DETAIL 1/00C-05 FOR PROPOSED LINER SYSTEM DETAILS.

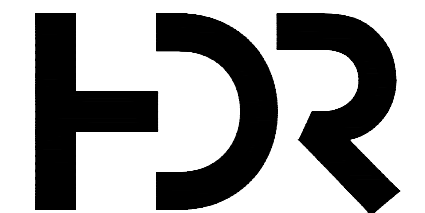

ISSUE	DATE	DESCRIPTION
A	01/31/2020	ISSUED FOR BID

PROJECT MANAGER	D. VOGT, P.E.
DESIGNED BY	K. PERERA
DRAWN BY	J. RAYMOND
CHECKED BY	M. ROBERTS
PROJECT NUMBER	10172630

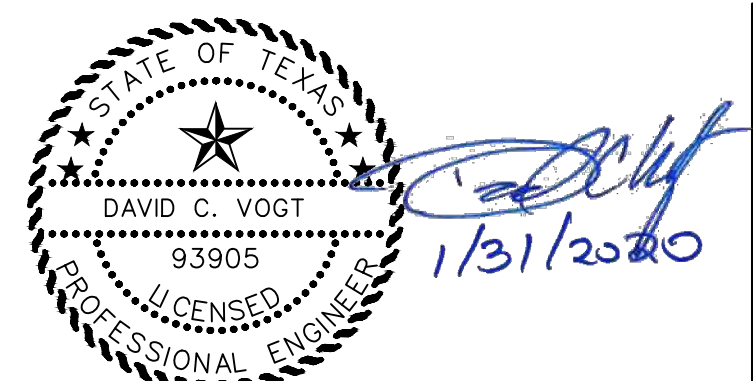

**MARTIN LAKE STEAM ELECTRICAL STATION
NEW SCRUBBER POND RELINE
RUSK COUNTY, TEXAS**



FILENAME | 00C-02.dwg
SCALE | 1" = 50'

SHEET
00C-02

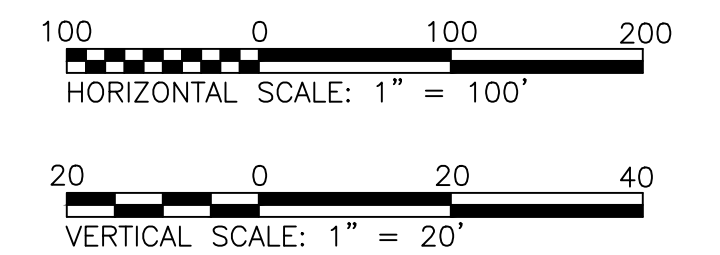

- LEGEND**
- TOP OF CCR MATERIAL
 - - - - - EXISTING GROUND SURFACE
 - PROPOSED GRADE

- NOTES:**
1. CCR ELEVATION FROM BATHYMETRIC SURVEY TAKEN FEBRUARY 2019 BY LACEY SURVEYING OF ARP, TEXAS. AT START OF PROJECT, OWNER WILL HAVE REMOVED BULK OF CCR MATERIAL FROM THE NEW SCRUBBER POND
 2. CONTRACTOR WILL REMOVE REMAINING CCR MATERIAL, ROCKS AND SEDIMENT WITHIN POND BEFORE INSTALLATION OF THE LINER SYSTEM.

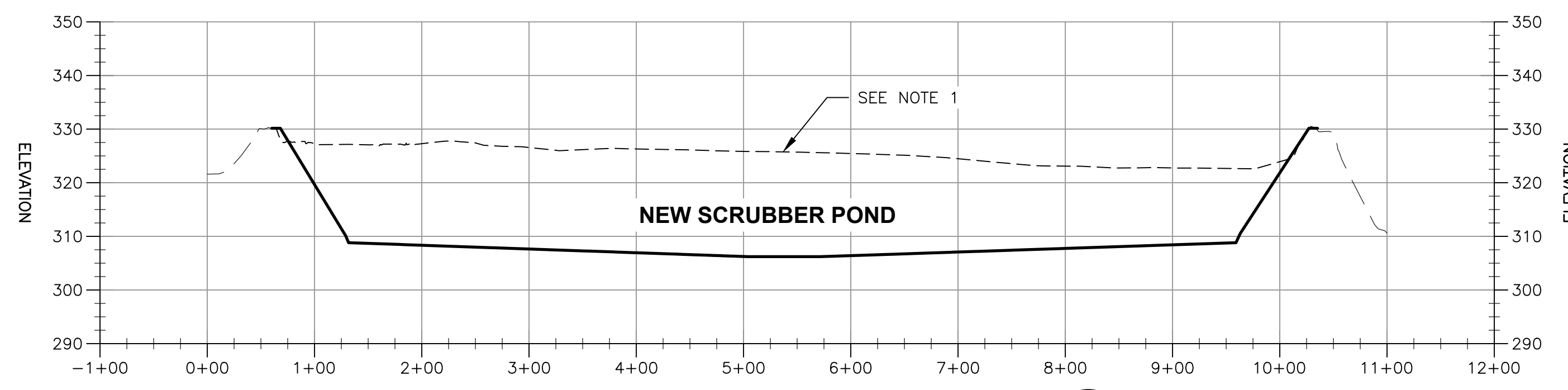

SECTION A-A
 HORIZONTAL SCALE: 1" = 100' ; VERTICAL SCALE: 1" = 20'
 A-A
 00C-02

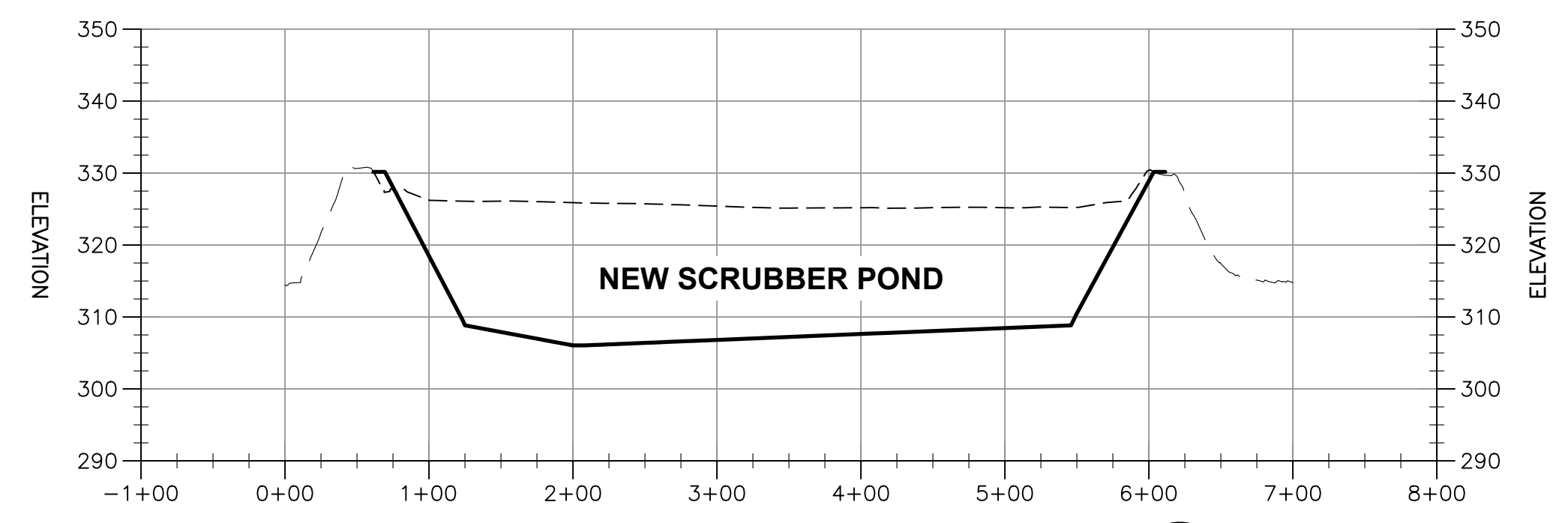

SECTION B-B
 HORIZONTAL SCALE: 1" = 100' ; VERTICAL SCALE: 1" = 20'
 B-B
 00C-02

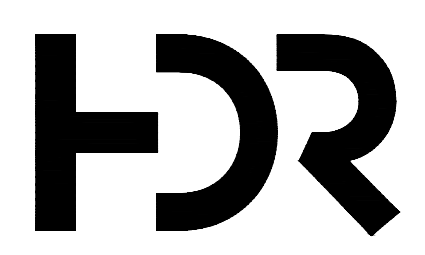

ISSUE	DATE	DESCRIPTION
A	01/31/2020	ISSUED FOR BID

PROJECT MANAGER	D. VOGT, P.E.
DESIGNED BY	K. PERERA
DRAWN BY	J. RAYMOND
CHECKED BY	M. ROBERTS
PROJECT NUMBER	10172630

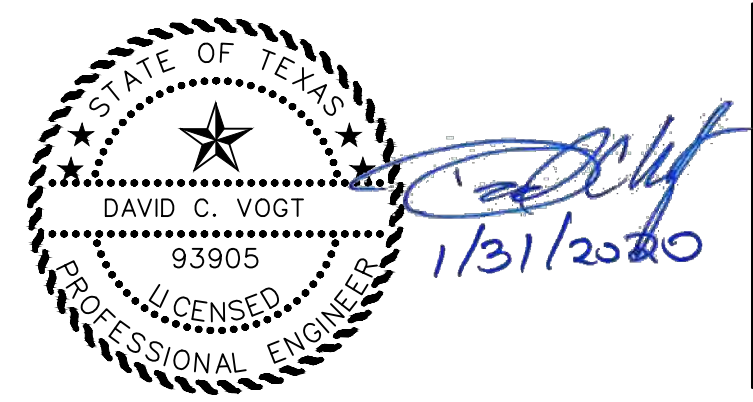

**MARTIN LAKE STEAM ELECTRICAL STATION
 NEW SCRUBBER POND RELINE
 RUSK COUNTY, TEXAS**



CROSS SECTIONS



FILENAME | 00C-03.dwg
SCALE | H: 1" = 100' ; V: 1" = 20'

SHEET
00C-03

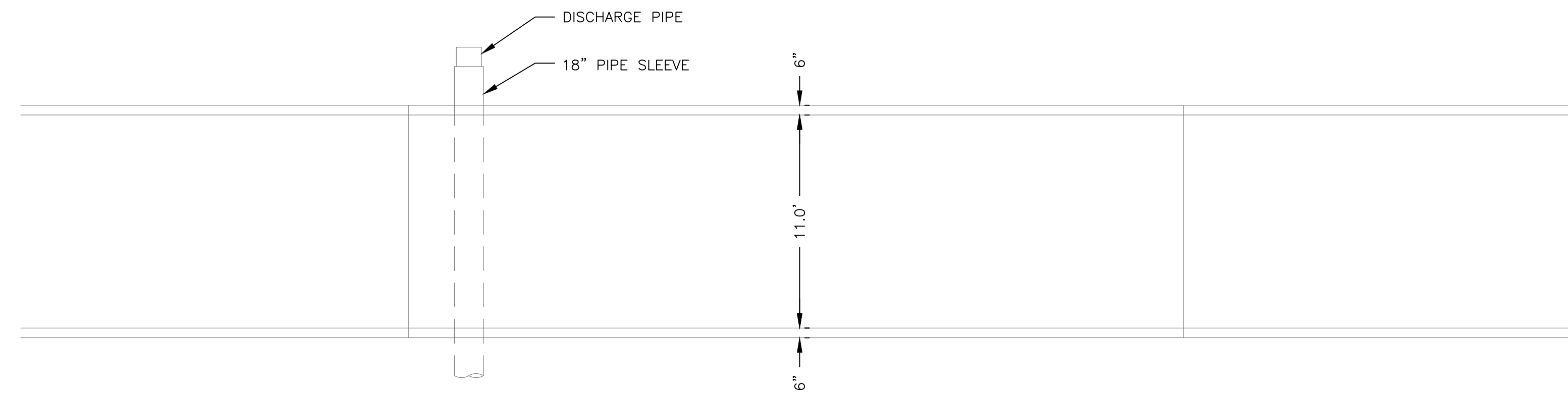

PIPE RACK PLAN VIEW
NOT TO SCALE

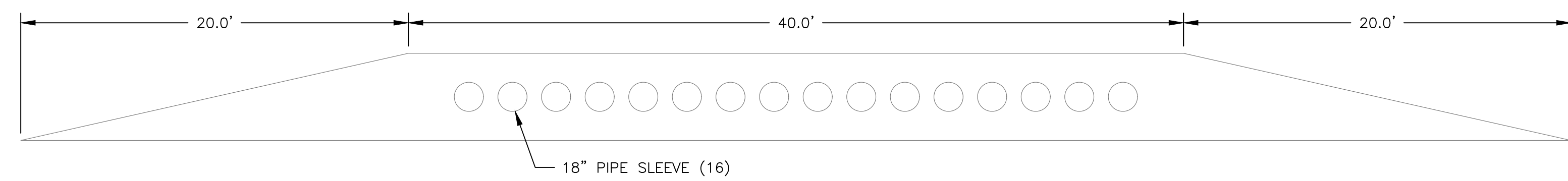

PIPE RACK PROFILE
NOT TO SCALE

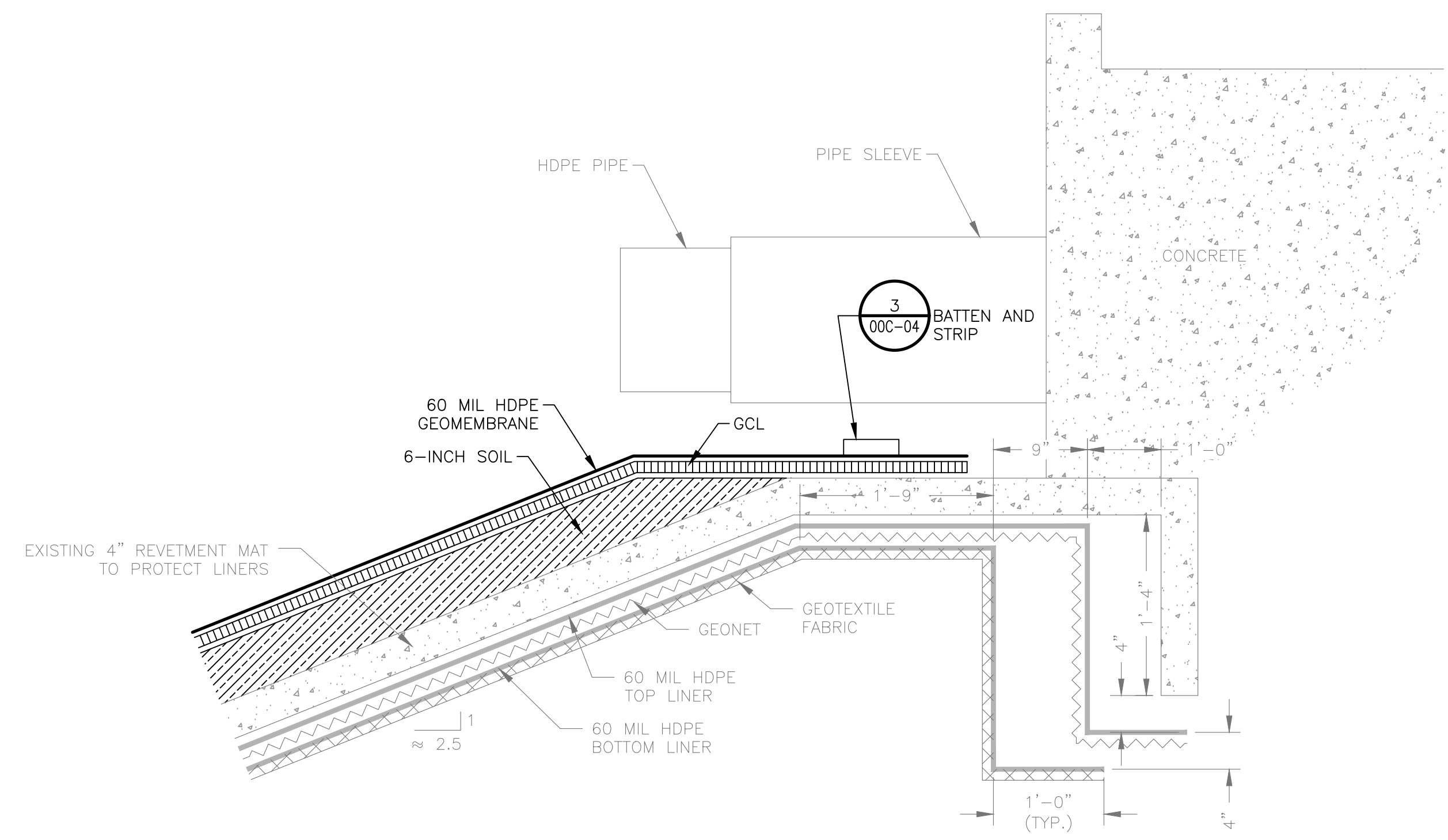

PIPE RACK SECTION
NOT TO SCALE

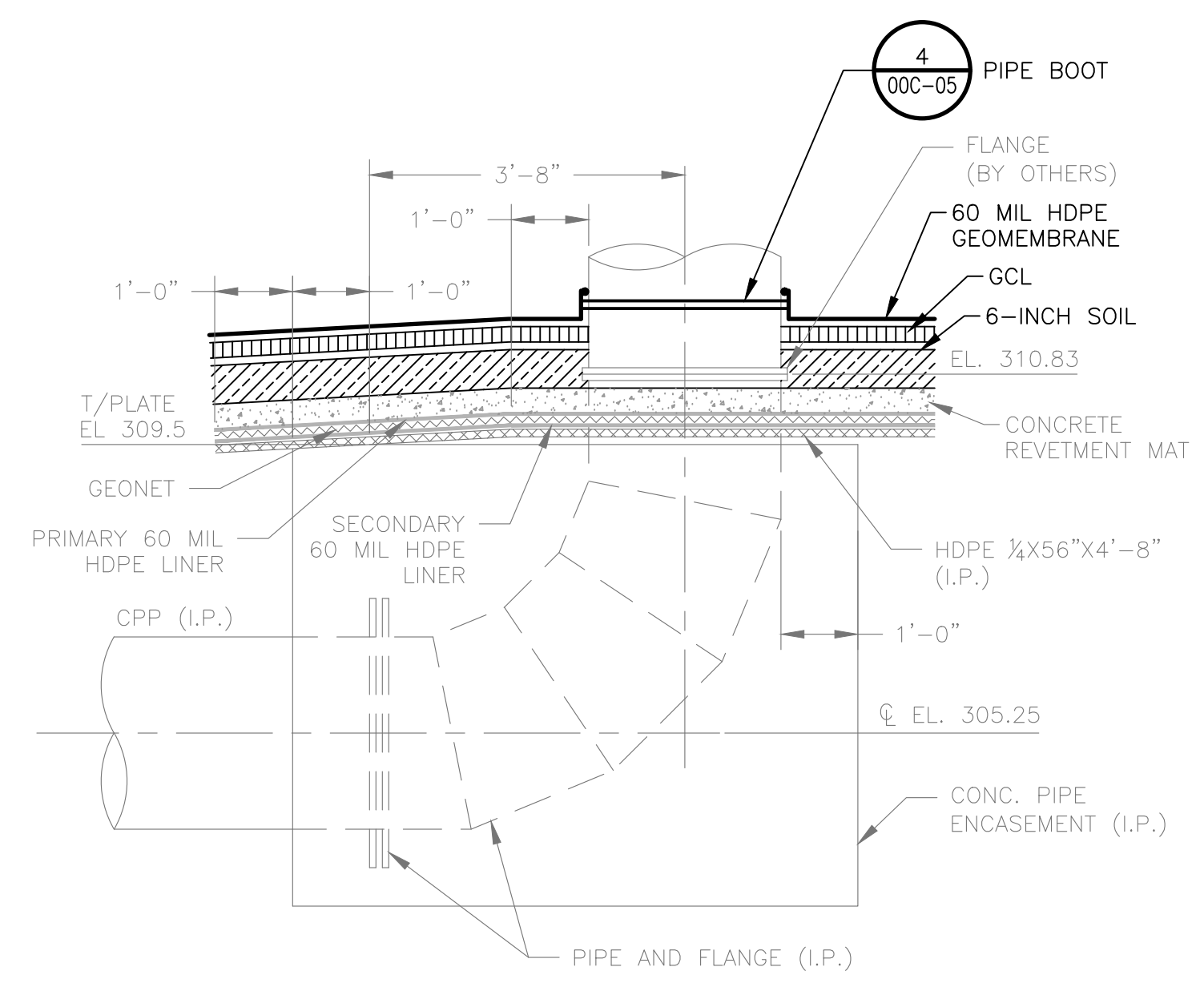

PIPE ENCASEMENT
NOT TO SCALE

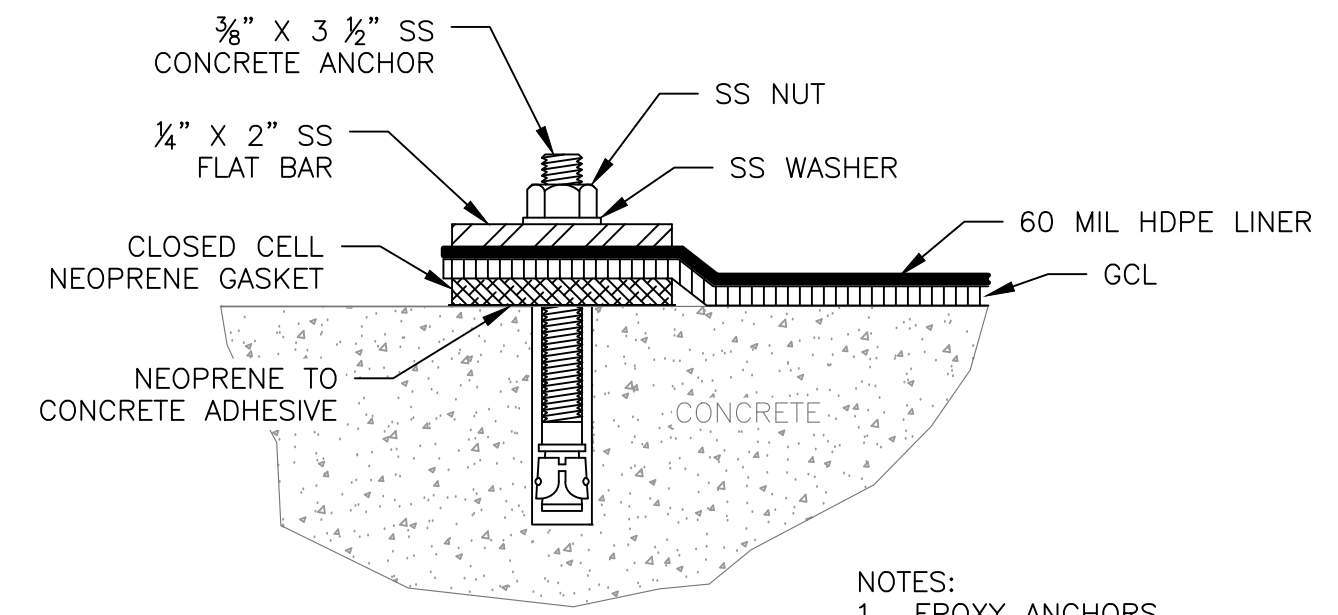

BATTEN AND STRIP CONNECTION AT ANCHOR TRENCH
NOT TO SCALE

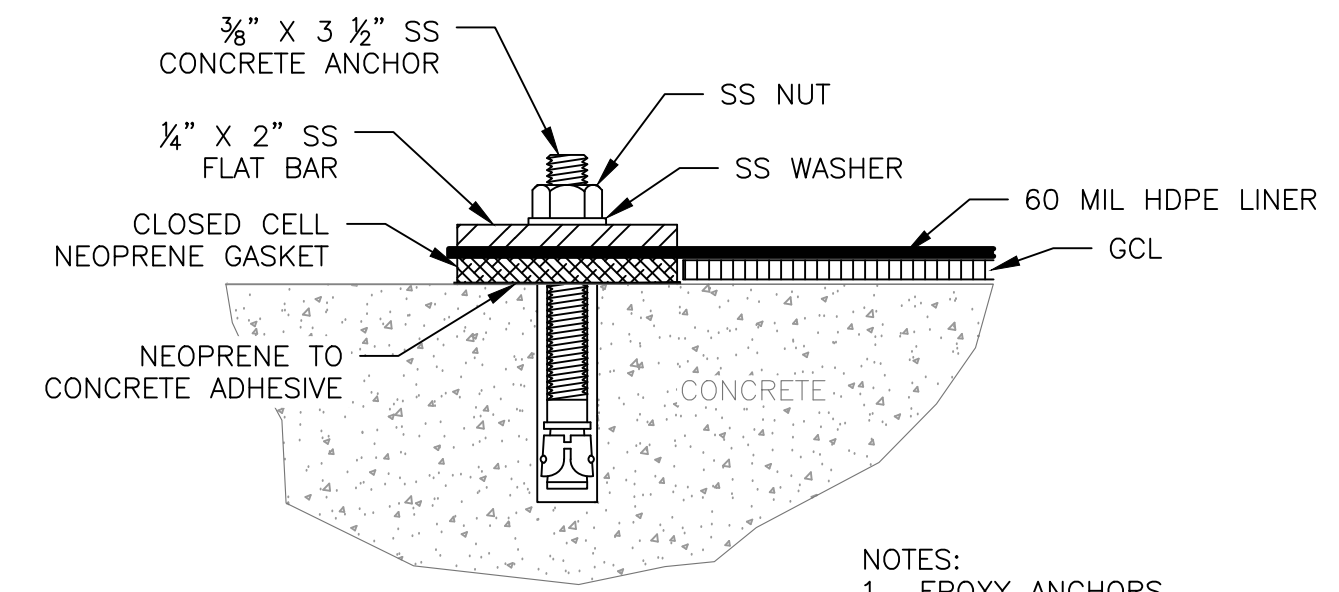

BATTEN AND STRIP CONNECTION BELOW WATER SURFACE
NOT TO SCALE

NOTES:
1. EPOXY ANCHORS
SPACED AT 6" O.C.

NOTES:
1. EPOXY ANCHORS
SPACED AT 6" O.C.

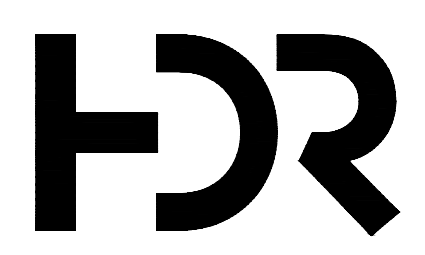

ISSUE	DATE	DESCRIPTION
A	01/31/2020	ISSUED FOR BID

PROJECT MANAGER	D. VOGT, P.E.
DESIGNED BY	K. PERERA
DRAWN BY	J. RAYMOND
CHECKED BY	M. ROBERTS
PROJECT NUMBER	10172630

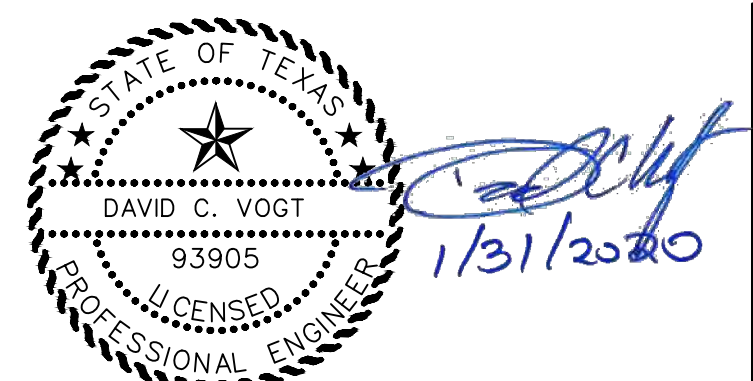

**MARTIN LAKE STEAM ELECTRICAL STATION
NEW SCRUBBER POND RELINE
RUSK COUNTY, TEXAS**



FILENAME | 00C-04.dwg
SCALE

SHEET
00C-04

**DETAILS
(1 OF 2)**

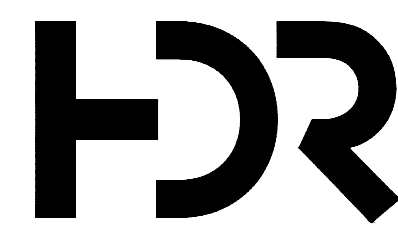
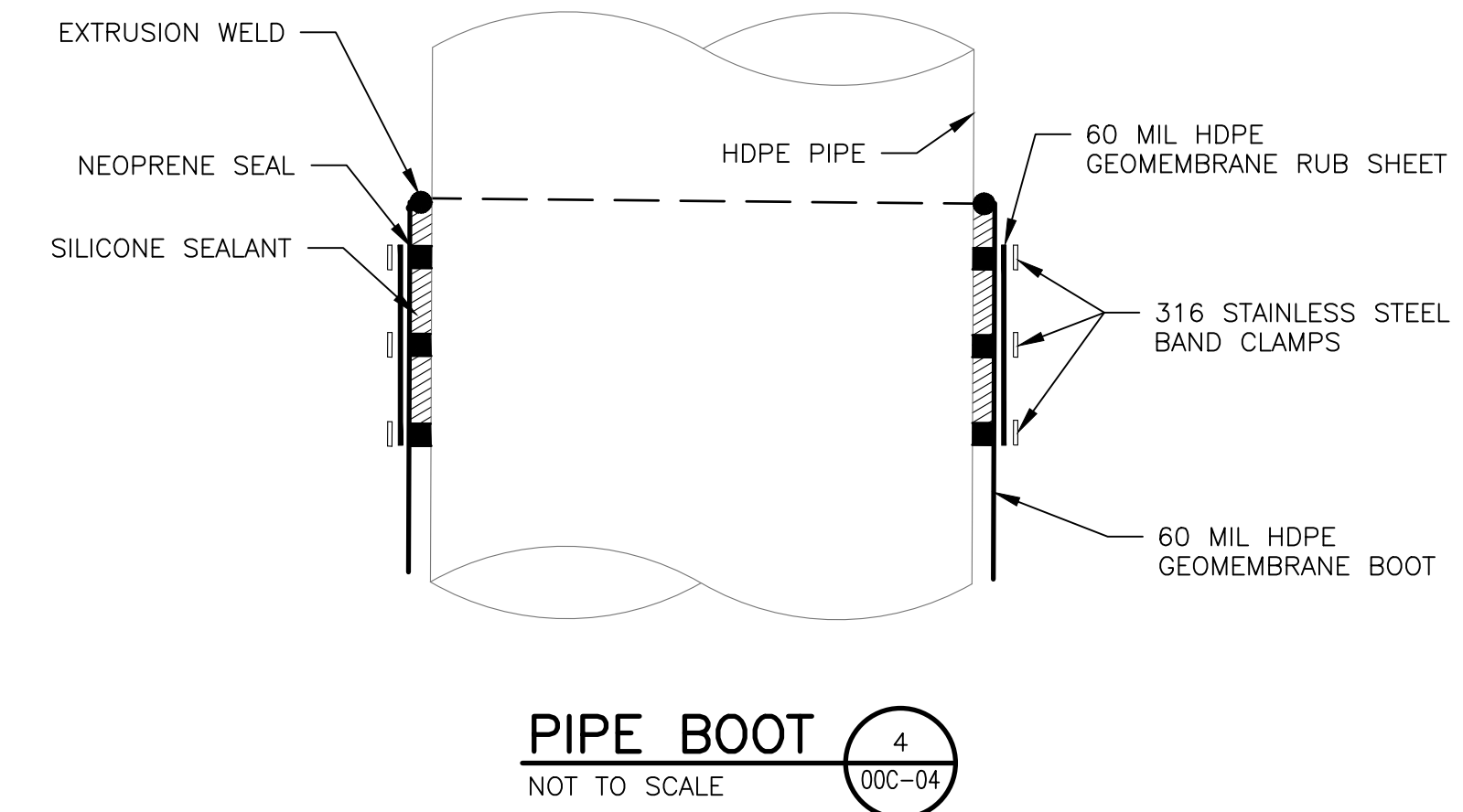
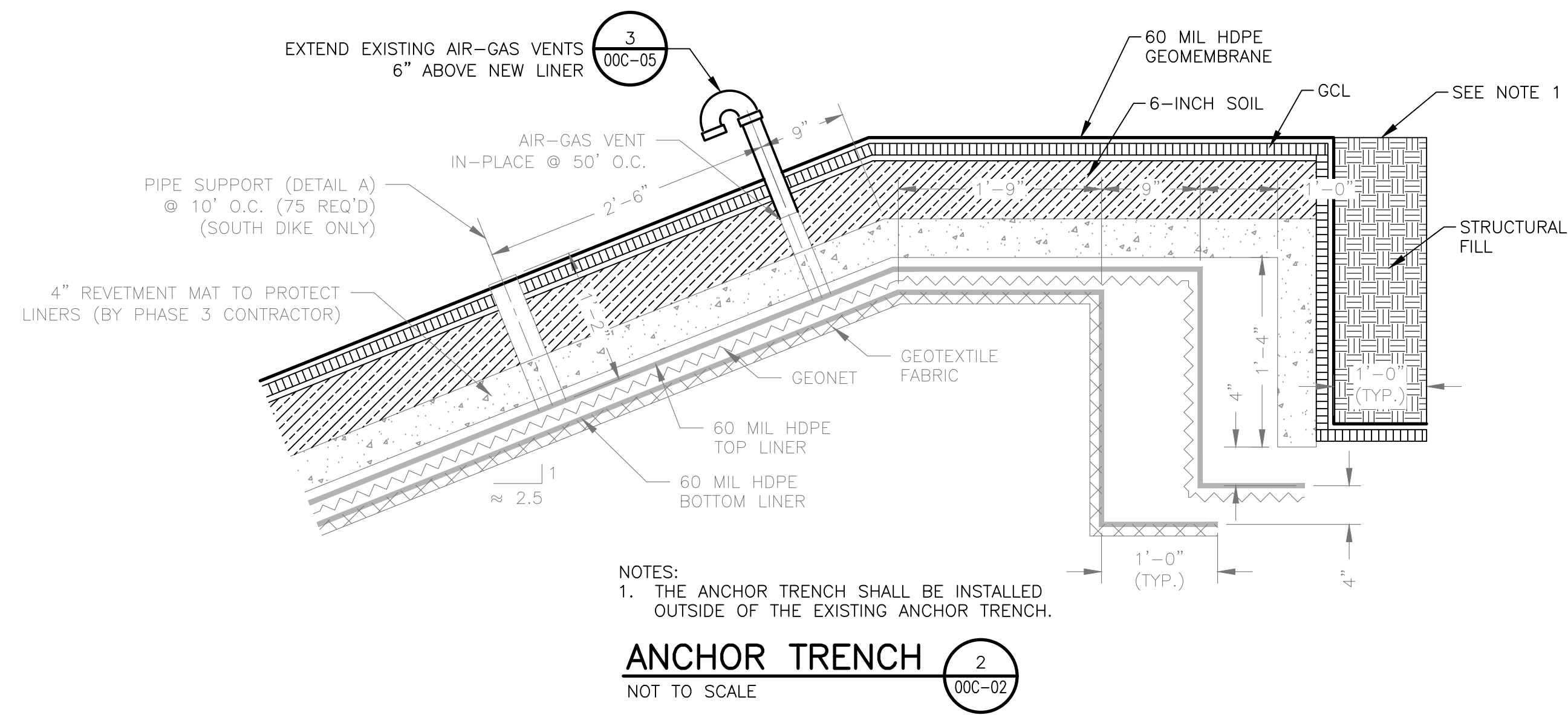
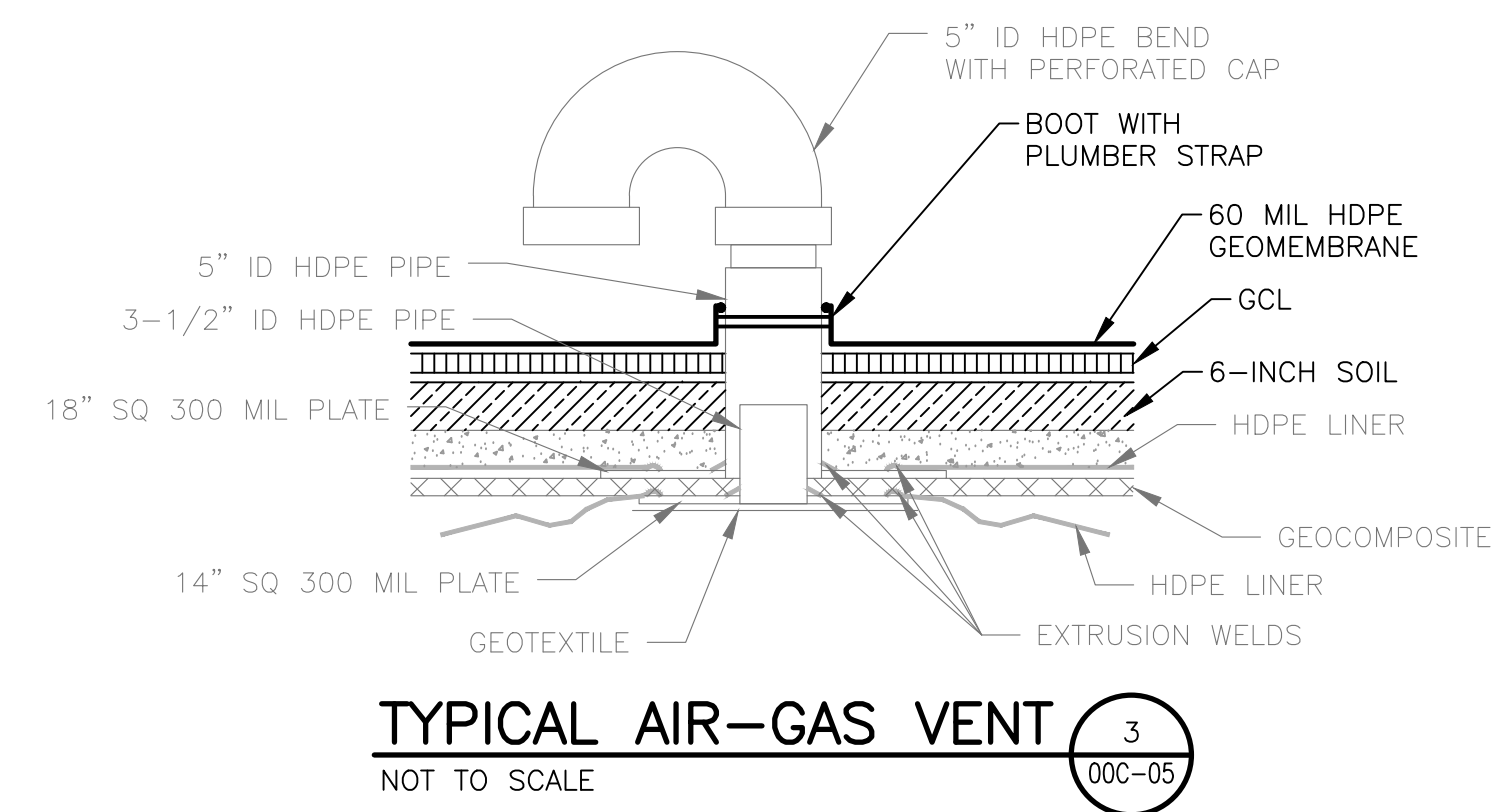
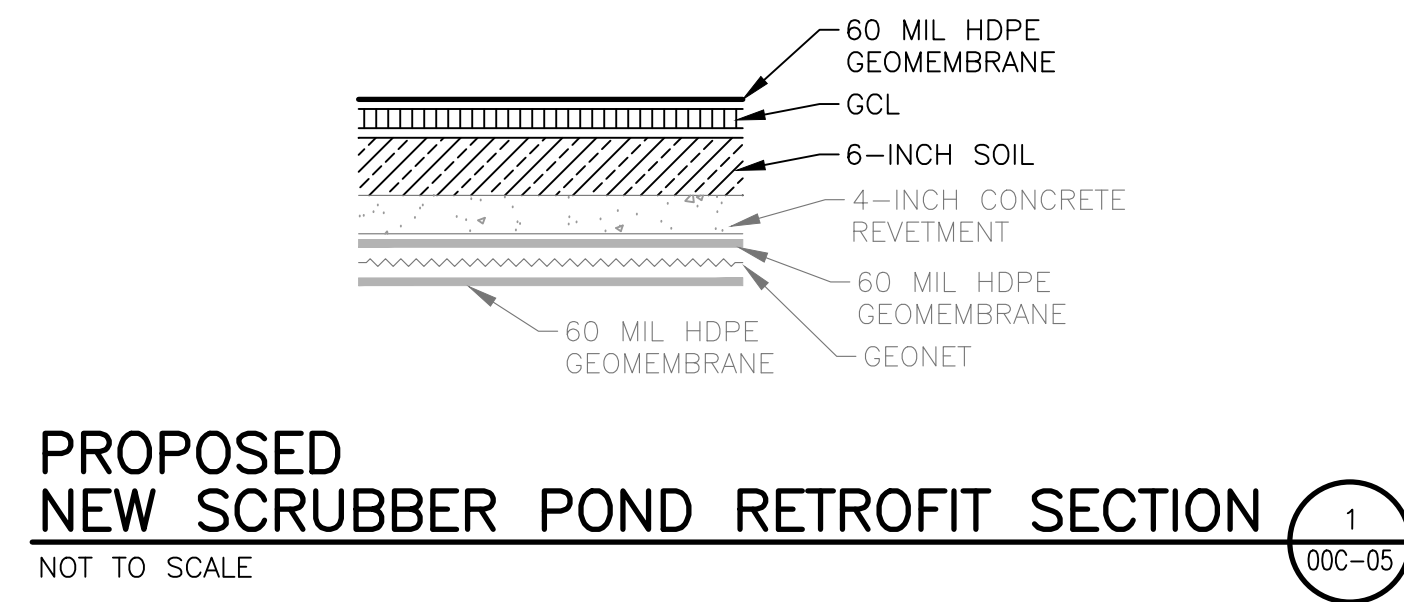

ISSUE	DATE	DESCRIPTION
A	01/31/2020	ISSUED FOR BID

PROJECT MANAGER	D. VOGT, P.E.
DESIGNED BY	K. PERERA
DRAWN BY	J. RAYMOND
CHECKED BY	M. ROBERTS
PROJECT NUMBER	10172630

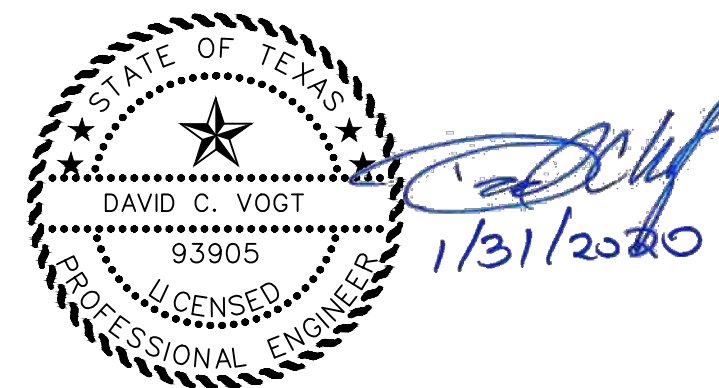

**MARTIN LAKE STEAM ELECTRICAL STATION
NEW SCRUBBER POND RELINE
RUSK COUNTY, TEXAS**



**DETAILS
(2 OF 2)**

FILENAME | 00C-05.dwg
SCALE | NOT TO SCALE

SHEET
00C-05



N

600 0 600 1200
SCALE IN FEET

LEGEND

- LIMITS OF CONSTRUCTION
- - - LIMITS OF PDP 5
- HAUL ROUTE

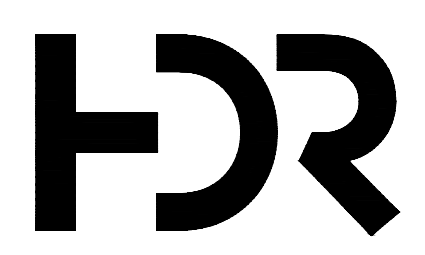

ISSUE	DATE	DESCRIPTION
A	01/31/2020	ISSUED FOR BID

PROJECT MANAGER	D. VOGT, P.E.
DESIGNED BY	K. PERERA
DRAWN BY	J. RAYMOND
CHECKED BY	M. ROBERTS
PROJECT NUMBER	10172630

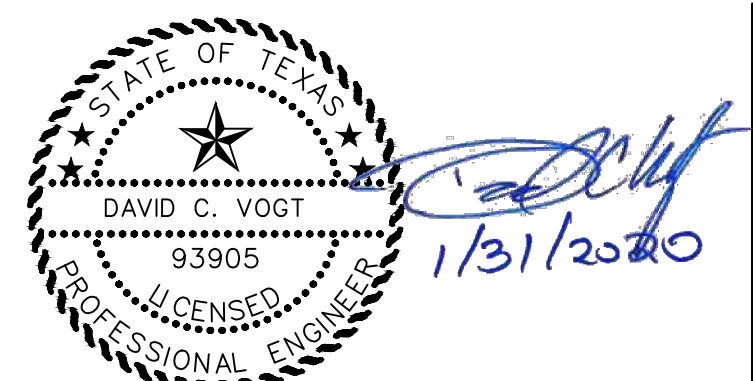

**MARTIN LAKE STEAM ELECTRICAL STATION
NEW SCRUBBER POND RELINE
RUSK COUNTY, TEXAS**



STOCKPILE AND HAUL ROUTE

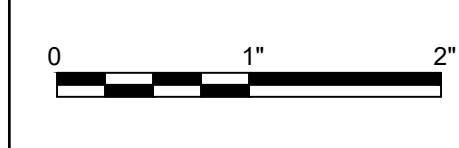

FILENAME | 00C-06.dwg
SCALE | 1" = 600'

SHEET
00C-06

APPENDIX F – COMPLIANCE DOCUMENTS

APPENDIX F1 – MAP OF GROUNDWATER MONITORING WELL LOCATIONS



LEGEND



DOWNGRADIENT CCR MONITORING WELL
 UPGRADIENT CCR MONITORING WELL

CLIENT
LUMINANT

PROJECT
**MARTIN LAKE STEAM ELECTRIC STATION
 TATUM, TEXAS**

TITLE
DETAILED SITE PLAN - ASH POND AREA

CONSULTANT



YYYY-MM-DD	2020-01-23
DESIGNED	AJD
PREPARED	AJD
REVIEWED	WFV
APPROVED	WFV

REFERENCE(S)

BASE MAP TAKEN FROM GOOGLE EARTH, IMAGERY DATED 4/6/17.

PROJECT NO.
19122262

REV.
0

FIGURE
1



EXPLANATION

 CCR Monitoring Well



Scale in Feet

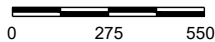

SOURCE:
Imagery from www.tnris.gov, Rusk County, aerial photographs, 2012.

MARTIN LAKE STEAM ELECTRIC STATION
TATUM, TEXAS

Figure 1

PDP 5 AREA
DETAILED SITE PLAN

PROJECT: 5164B

BY: AJD

REVISIONS

DATE: SEPT., 2017

CHECKED: PJB

APPENDIX F2 – WELL CONSTRUCTION DIAGRAMS AND DRILLING LOGS

Ash Pond Area

Luminant

Log of Boring: H-26

Martin Lake Steam Electric Station Tatum, TX	Completion Date:	9/14/2015	Drilling Method:	Sonic
	Drilling Company:	Walker-Hill Environmental	Borehole Diameter (in.):	6.5
PBW Project No. 5164B	Driller:	Timmy Beach	Total Depth (ft):	50
	Driller's License:	5814M	TOC Elevation (ft. AMSL):	
	Logged By:	Ryan Francis	Northing:	
	Sampling Method:	4"x10' Core barrel	Easting:	

Depth (ft)	Well Materials	Recovery (ft/ft)	USCS	Lithologic Description
0			ML	(0 - 3) Silty CLAY, dark brown, dry, soft to firm, weak cementation, flat, low plasticity
4		10.0/10.0	SC	(3 - 7) Sandy CLAY, red/orange with gray clay ribbons, dry, soft to firm, weak cementation, medium plasticity, minor rounded pebbles
8				(7 - 11) Silty SAND, gray, dry, soft, weak cementation, subrounded, sharp contact
12		10.0/10.0		
16			ML	
20				(11 - 30) Clayey silty SAND, tan with red and gray ribbons, moist to wet, soft, weak cementation, medium plasticity
24		10.0/10.0		
28				
32			SP	
36		10.0/10.0		(30 - 40) SAND, tan and orange, fine grained, higher clay content (31'-34'), wet, very soft to soft, low to medium plasticity
40			SW	
44		10.0/10.0		(40 - 44) SAND, red, wet, soft to firm, moderate cementation, heavy iron content, iron concretions ("rocky" texture)
48			SP	
52				(44 - 50) SAND, red and gray, wet, soft, fine grained, subrounded, gradual color change to dark brown/black (47'-50'), moisture content decreases with depth, hard sand (48'-50')

PBW

Pastor, Behling & Wheeler, LLC
2201 Double Creek Dr., Suite 4004
Round Rock, TX 78664
Tel (512) 671-3434 Fax (512) 671-3446

Notes:

1. This log should not be used separately from the report to which it is attached.

Well Materials

(0-35) Casing, 2" Sch 40 FJT PVC
(35-40) Screen, 2" Sch 40 FJT PVC, 0.010" slot

Annular Materials

(0'-31') Grout
(31'-33') Bentonite pellets
(33'-40') 20/40 sand

Luminant

Log of Boring: H-27

Martin Lake Steam Electric Station Tatum, TX	Completion Date:	9/15/2015	Drilling Method:	Sonic
	Drilling Company:	Walker-Hill Environmental	Borehole Diameter (in.):	6.5
PBW Project No. 5164B	Driller:	Timmy Beach	Total Depth (ft):	50
	Driller's License:	5814M	TOC Elevation (ft. AMSL):	
	Logged By:	Ryan Francis	Northing:	
	Sampling Method:	4"x10' Core barrel	Easting:	

Depth (ft)	Well Materials	Recovery (ft/ft)	USCS	Lithologic Description
0				
4		10.0/10.0	CH	(0 - 20) CLAY, orange and brown mottling, minor black streaking, blocky, moist, soft to hard, low to high plasticity, dry and variable sand content (5'-7'), wet at 20'
8		10.0/10.0		
12		10.0/10.0	SP	(20 - 21) SAND, gray, moist, soft, subrounded, sharp contact
16		10.0/10.0		
20		10.0/10.0	CL	(21 - 28) CLAY, gray and orange, blocky, moist, firm to hard, moderate cementation, low plasticity
24		10.0/10.0		
28		10.0/10.0	SP	(28 - 40) SAND, light gray to tan/orange, moist to wet, soft, none to low plasticity, minor clay content decreasing with depth
32		10.0/10.0		
36		10.0/10.0	CL	(40 - 44) Sandy CLAY, orange and gray, moist, firm, low to medium plasticity, flat, sharp contact, very hard and little to no sand at 43'
40		10.0/10.0		
44		10.0/10.0	SP	(44 - 50) Clayey SAND, orange and gray, wet, soft, low plasticity, fine grained, decreasing clay content with depth, sharp contact, color change to brown at 48'
48		10.0/10.0		
52				

PBW

Pastor, Behling & Wheeler, LLC
2201 Double Creek Dr., Suite 4004
Round Rock, TX 78664
Tel (512) 671-3434 Fax (512) 671-3446

Notes:

1. This log should not be used separately from the report to which it is attached.

Well Materials

(0-45) Casing, 2" Sch 40 FJT PVC
(45-50) Screen, 2" Sch 40 FJT PVC, 0.010" slot

Annular Materials

(0'-41') Grout
(41'-43') Bentonite pellets
(43'-50') 20/40 sand

Luminant

Log of Boring: H-28

Martin Lake Steam Electric Station Tatum, TX	Completion Date:	9/15/2015	Drilling Method:	Sonic
	Drilling Company:	Walker-Hill Environmental	Borehole Diameter (in.):	6.5
PBW Project No. 5164B	Driller:	Timmy Beach	Total Depth (ft):	40
	Driller's License:	5814M	TOC Elevation (ft. AMSL):	
	Logged By:	Ryan Francis	Northing:	
	Sampling Method:	4"x10' Core barrel	Easting:	

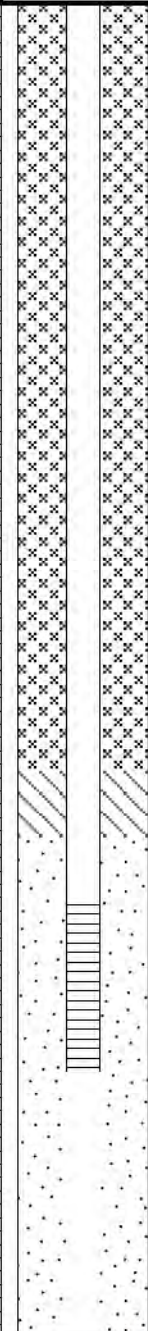
Depth (ft)	Well Materials	Recovery (ft/ft)	USCS	Lithologic Description	
0		10.0/10.0	SP	(0 - 6) Soil with SAND, tan, dry, firm, moderate cementation, hard packed	
2				SC	(6 - 21) Clayey SAND, moist, soft to firm, weak cementation, none to low plasticity, flat, 6" gray fine to very fine sand lense at 10', gray and orange mottling (11'-21'), fine grained
4			SP/SC		(21 - 30) Clayey SAND, tan and orange, wet, soft to firm, low plasticity, none to weak cementation, variation in clay content with depth, highest clay content at 21', more orange and less clay (29'-30')
6					SP
8			CL	(33 - 40) Silty CLAY, dark gray, moderate sand, dry, hard, weak cementation, flat	
10					
12					
14					
16					
18					
20					
22					
24					
26					
28					
30					
32					
34					
36					
38					
40					

PBW

Pastor, Behling & Wheeler, LLC
2201 Double Creek Dr., Suite 4004
Round Rock, TX 78664
Tel (512) 671-3434 Fax (512) 671-3446

Notes:

1. This log should not be used separately from the report to which it is attached.

Well Materials

(0-27) Casing, 2" Sch 40 FJT PVC
(27-32) Screen, 2" Sch 40 FJT PVC, 0.010" slot

Annular Materials

(0'-23') Grout
(23'-25') Bentonite pellets
(25'-32') 20/40 sand

Luminant

Log of Boring: H-29

Martin Lake Steam Electric Station Tatum, TX	Completion Date:	9/23/2015	Drilling Method:	Sonic
	Drilling Company:	Walker-Hill Environmental	Borehole Diameter (in.):	6.5
PBW Project No. 5164B	Driller:	Timmy Beach	Total Depth (ft):	60
	Driller's License:	5814M	TOC Elevation (ft. AMSL):	
	Logged By:	Ryan Francis	Northing:	
	Sampling Method:	4"x10' Core barrel	Easting:	

Depth (ft)	Well Materials	Recovery (ft/ft)	USCS	Lithologic Description
0			FILL	(0 - 2) Hard rock road bed, dry
4		10.0/10.0	SC	(2 - 18) Clayey SAND, orange and gray mottling, very fine grained, dry to moist, firm, weak cementation, low to medium plasticity, increasing clay content with depth
8				
12		10.0/10.0		
16				
20			CL	(18 - 30) CLAY, orange, moist, firm, low to medium plasticity, very little sand or silt, black striping at 22', increasing sand content with depth (28'-30')
24		10.0/10.0		
28				
32			CH	(30 - 36) CLAY, orange, moist, soft, friable, high plasticity, minor silt
36		10.0/10.0		
40			CL/SC	(36 - 45) Sandy CLAY/Clayey SAND, orange/gray/red mottling, friable, wet, soft to firm, low to medium plasticity, increasing clay content with depth
44		10.0/10.0		
48			CH	(45 - 48) CLAY with sand, orange and gray mottling, wet, soft, high plasticity
52			SP	(48 - 57) SAND, gray, wet, soft, one to low plasticity, some black roots/ organics, interspersed clay lenses
56		10.0/10.0		
60			CL	(57 - 60) Silty CLAY, gray/brown, dry, hard, weak cementation, sharp contact

PBW

Pastor, Behling & Wheeler, LLC
2201 Double Creek Dr., Suite 4004
Round Rock, TX 78664
Tel (512) 671-3434 Fax (512) 671-3446

Notes:

1. This log should not be used separately from the report to which it is attached.

Well Materials

(0-52) Casing, 2" Sch 40 FJT PVC
(52-57) Screen, 2" Sch 40 FJT PVC, 0.010" slot

Annular Materials

(0'-48') Grout
(48'-50') Bentonite pellets
(50'-57') 20/40 sand

Luminant

Log of Boring: H-31

Martin Lake Steam Electric Station Tatum, TX	Completion Date:	9/24/2015	Drilling Method:	Sonic
	Drilling Company:	Walker-Hill Environmental	Borehole Diameter (in.):	6.5
PBW Project No. 5164B	Driller:	Timmy Beach	Total Depth (ft):	60
	Driller's License:	5814M	TOC Elevation (ft. AMSL):	
	Logged By:	Ryan Francis	Northing:	
	Sampling Method:	4"x10' Core barrel	Easting:	

Depth (ft)	Well Materials	Recovery (ft/ft)	USCS	Lithologic Description
0			FILE	(0 - 1) Hard, packed gravel road bed, dry
4		10.0/10.0	SC	(1 - 12) Clayey SAND, orange, dry to moist, soft to firm, low plasticity, fine grained, increasing clay content with depth, gray clay ribbons at 10'
8				
12		5.0/10.0	SP	(12 - 20) SAND, orange with red and gray mottling, dry to moist, soft, none to low plasticity, weak cementation, fine grained, very little clay
16				
20		10.0/10.0	SC/CL	(20 - 30) Sandy CLAY, orange, dry to moist, firm, crumbly, color variation with depth, low plasticity, some gray sand lenses, very fine grained, color change to gray at 29'
24				
28		10.0/10.0	CL/SC	(30 - 41) Sandy CLAY, / Clayey SAND, gray and tan, moist, soft, fine grained, low plasticity, variations in clay content and firmness with depth, moisture content changes to wet at 35'
32				
36		10.0/10.0	SP	(41 - 57) SAND, orange/tan, wet, very soft, fine grained, subrounded, increasing red color with depth starting at 52', hard iron concretion layer with some black staining at 55'
40				
44		10.0/10.0		
48				
52		10.0/10.0		
56				
60			CL	(57 - 60) Sandy CLAY, gray, dry to moist, hard, fine grained, weak cementation, low plasticity, flat

PBW

Pastor, Behling & Wheeler, LLC
2201 Double Creek Dr., Suite 4004
Round Rock, TX 78664
Tel (512) 671-3434 Fax (512) 671-3446

Notes:

1. This log should not be used separately from the report to which it is attached.

Well Materials

(0-42) Casing, 2" Sch 40 FJT PVC
(42-52) Screen, 2" Sch 40 FJT PVC, 0.010" slot

Annular Materials

(0'-38') Grout
(38'-40') Bentonite pellets
(40'-52') 20/40 sand

Luminant

Log of Boring: H-32

Martin Lake Steam Electric Station Tatum, TX	Completion Date:	9/24/2015	Drilling Method:	Sonic
	Drilling Company:	Walker-Hill Environmental	Borehole Diameter (in.):	6.5
PBW Project No. 5164B	Driller:	Timmy Beach	Total Depth (ft):	60
	Driller's License:	5814M	TOC Elevation (ft. AMSL):	
	Logged By:	Ryan Francis	Northing:	
	Sampling Method:	4"x10' Core barrel	Easting:	

Depth (ft)	Well Materials	Recovery (ft/ft)	USCS	Lithologic Description
0			FILE	(0 - 1) Hard, packed gravel road bed, dry
4		10.0/10.0	SC/CL	(1 - 10) Sandy CLAY/Clayey SAND, orange/tan, dry, firm, fine grained, low plasticity, weak cementation
8				
12		10.0/10.0	CH	(10 - 21) CLAY with minor silt/sand, orange with some black streaks, moist, firm, high plasticity, gradual contact
16				
20			SP	(21 - 23.5) SAND, gray, dry, soft to firm, friable, fine grained
24		10.0/10.0		
28			CH	(23.5 - 38) CLAY, orange/tan/gray, moist, soft to firm, unconsolidated, high plasticity, minor sand at 30', tan and gray with orange stripes (30'-38'), sharp contact
32				
36		10.0/10.0		
40			SP	(38 - 57) SAND, orange/tan, moist to wet, very soft to soft, fine grained, subrounded, minor clay, low plasticity, no clay content at 42', gradual coarsening of sand grains (48'-55'), some gray streakings at 49', color change to reddish brown at 52'
44		10.0/10.0		
48				
52				
56		10.0/10.0		
60			CL	(57 - 60) Sandy CLAY, dark red and brown, wet, soft, low plasticity, layer of dark red concretions at 57', weak cementation, flat

PBW

Pastor, Behling & Wheeler, LLC
2201 Double Creek Dr., Suite 4004
Round Rock, TX 78664
Tel (512) 671-3434 Fax (512) 671-3446

Notes:

1. This log should not be used separately from the report to which it is attached.

Well Materials

(0-42) Casing, 2" Sch 40 FJT PVC
(42-52) Screen, 2" Sch 40 FJT PVC, 0.010" slot

Annular Materials

(0'-38') Grout
(38'-40') Bentonite pellets
(40'-52') 20/40 sand

Luminant

Log of Boring: H-33

Martin Lake Steam Electric Station Tatum, TX	Completion Date:	9/14/2015	Drilling Method:	Sonic
	Drilling Company:	Walker-Hill Environmental	Borehole Diameter (in.):	6.5
PBW Project No. 5164B	Driller:	Timmy Beach	Total Depth (ft):	60
	Driller's License:	5814M	TOC Elevation (ft. AMSL):	
	Logged By:	Ryan Francis	Northing:	
	Sampling Method:	4"x10' Core barrel	Easting:	

Depth (ft)	Well Materials	Recovery (ft/ft)	USCS	Lithologic Description
0			ML	(0 - 4) Silty CLAY, minor sand, red and orange with gray ribbons, dry, soft to firm, low to medium plasticity, flat
4		10.0/10.0	CH	(4 - 12) CLAY, red with gray concretions, moist, soft to firm, high plasticity, gradual contact
8				
12		10.0/10.0	ML	(12 - 24) Sandy SILT, gray and red, dry, soft, weak cementation, sharp contact, red and gray clay lense at 19'
16				
20				
24		10.0/10.0	CL	(24 - 28) Clay, red, moist to wet, soft to firm, high plasticity, pebbles present
28				
32			SP	(28 - 34) SAND, gray, wet, soft to firm, minor clay, low to medium plasticity, subrounded, increasing clay content with depth, sharp contact
36		10.0/10.0	CL	(34 - 39) CLAY, orange and gray mottling, dry, very hard, moderate cementation, low plasticity
40				
44		10.0/10.0	CL	(39 - 46) Sandy CLAY, orange and gray, moist to wet, firm, medium plasticity, weak cementation, increasing sand content with depth
48				
52			ML	(46 - 60) Sandy SILT, dark gray, dry, hard, flat
56		10.0/10.0		
60				

PBW

Pastor, Behling & Wheeler, LLC
2201 Double Creek Dr., Suite 4004
Round Rock, TX 78664
Tel (512) 671-3434 Fax (512) 671-3446

Notes:

1. This log should not be used separately from the report to which it is attached.

Well Materials

(0-41) Casing, 2" Sch 40 FJT PVC
(41-46) Screen, 2" Sch 40 FJT PVC, 0.010" slot

Annular Materials

(0'-37') Grout
(37'-39') Bentonite pellets
(39'-46') 20/40 sand

PDP5



BORING/WELL CONSTRUCTION LOG

Project Number: 08-1388	Boring/Well Number: MW-17A
Project Name: Martin Lake SES	Date Drilled: October 1, 2008
Location: 8850 FM 2658 Tatum, TX	Casing Type/Diameter: PVC/2" ID
Drilling Method: HSA	Screen Type/Diameter: PVC/0.01"
Sampling Method: CT	Gravel Pack Type: 8/16 Grade Silica Sand
Ground Elevation: 384.63' msl	Grout Type: Bentonite Pellets
Top of Casing Elevation: 387.53' msl	Depth to Water/Date: 26.62' BTOC/10-09-2008
Logged by: T. Ripley	Ground Water Elevation/Date: 360.91' msl/10-09-2008
Remarks:	Drilling Co./Driller: SCI / M. Bridges

PID (ppm)	Blow Counts	Recovery (%)	Sampling Method	Sample	Depth (ft. BGL)	U.S.C.S	Graphic Log	Lithologic Description	Contact Depth	Well Diagram
NA	NA	NA	CT	NA	10			See MW-17B boring log for Lithologic Description		
					20					
					30					
					40					
					50					
								The boring was terminated and the well was set at 47' bgs. The well was completed with a protective slickup which requires approximately 3 feet of additional casing above grade.	50.0	



**GREEN STAR
ENVIRONMENTAL**

BORING/WELL CONSTRUCTION LOG

Project Number:	08-1388	Boring/Well Number:	MW-18A
Project Name:	Martin Lake SES	Date Drilled:	October 2, 2008
Location:	8850 FM 2658 Tatum, TX	Casing Type/Diameter:	PVC/2" ID
Drilling Method:	HSA	Screen Type/Diameter:	PVC/0.01"
Sampling Method:	CT	Gravel Pack Type:	8/16 Grade Silica Sand
Ground Elevation:	410.83' msl	GROUT Type:	Bentonite Pellets
Top of Casing Elevation:	414.43' msl	Depth to Water/Date:	43.17' BTOC/10-09-2008
Logged by:	T. Ripley	Ground Water Elevation/Date:	371.26' msl/10-09-2008
Remarks:		Drilling Co./Driller:	SCI / M. Bridges

PID (ppm)	Blow Counts	Recovery (%)	Sampling Method	Sample	Depth (ft. BGL)	U.S.C.S	Graphic Log	Lithologic Description	Contact Depth	Well Diagram
NA	NA	NA	CT	NA				See MW-18B boring log for Lithologic Description		<p> Cement/Concrete Well Cover Bentonite Pellets to 45' 50' Casing 20' Screen with 2" End Cap Sand Backfill of Annular Space from 45' to 67' </p>
					10					
					20					
					30					
					40				▽	
					50					
					60					
					70			The boring was terminated and the well was set at 67' bgs. The well was completed with a protective stickup which requires approximately 3 feet of additional casing above grade.		



BORING/WELL CONSTRUCTION LOG

Project Number: 08-1388	Boring/Well Number: MW-19
Project Name: Martin Lake SES	Date Drilled: September 30, 2008
Location: 8850 FM 2658 Tatum, TX	Casing Type/Diameter: PVC/2" ID
Drilling Method: HSA	Screen Type/Diameter: PVC/0.01"
Sampling Method: CT	Gravel Pack Type: 20/40 Grade Silica Sand
Ground Elevation: 367.84' msl	Grout Type: Bentonite Pellets
Top of Casing Elevation: 371.23' msl	Depth to Water/Date: 13.89' BTOC/10-09-2008
Logged by: T. Ripley	Ground Water Elevation/Date: 357.34' ms/10-09-2008
	Drilling Co./Driller: SCI / M. Bridges

Remarks:

PID (ppm)	Blow Counts	Recovery (%)	Sampling Method	Sample	Depth (ft BGL)	U.S.C.S	Graphic Log	Lithologic Description	Contact Depth	Well Diagram
NA	NA	90	CT	NA		SC		Moist, medium dense, reddish-brown, CLAYEY SAND (fine-grained SAND)		
						CL		Moist, soft, reddish-brown, SANDY CLAY		
					5	SP		Moist, loose, reddish-brown, fine-grained SAND -gray	5.0	
		60				CL		Moist to wet, soft, brown, SANDY CLAY (fine-grained SAND) -stiff -light gray	10.0	
						CL		Moist, very stiff, light gray, SILTY CLAY		
		100				SC		Moist, dense, gray and reddish-brown, CLAYEY SAND (fine-grained SAND)	15.0	
					15	SP		Wet, loose, light gray and reddish-brown, fine-grained SAND -medium dense		
		70				SC		Wet, medium dense, light gray and reddish-brown, CLAYEY SAND (fine-grained SAND) -stringer of dense	20.0	
						ML		Moist, very stiff, gray CLAYEY SILT with some iron staining	25.0	
		100			20					
					25					
<p>The boring was terminated and the well was set at 25' bgs. The well was completed with a protective stickup which requires approximately 3 feet of additional casing above grade.</p>										



GREEN STAR ENVIRONMENTAL

BORING/WELL CONSTRUCTION LOG

Project Number: 08-1388	Boring/Well Number: MW-20A
Project Name: Martin Lake SES	Date Drilled: September 30, 2008
Location: 8850 FM 2658 Tatum, TX	Casing Type/Diameter: PVC/2" ID
Drilling Method: HSA	Screen Type/Diameter: PVC/0.01"
Sampling Method: CT	Gravel Pack Type: 20/40 Grade Silica Sand
Ground Elevation: 395.95' msl	Grout Type: Bentonite Pellets
Top of Casing Elevation: 398.34' msl	Depth to Water/Date: 29.19' BTOC/10-09-2008
Logged by: T. Ripley	Ground Water Elevation/Date: 369.65' msl/10-09-2008
Remarks:	Drilling Co./Driller: SCI / M. Bridges

PID (ppm)	Blow Counts	Recovery (%)	Sampling Method	Sample	Depth (ft. BGL)	U.S.C.S	Graphic Log	Lithologic Description	Contact Depth	Well Diagram
NA	NA	NA	CT	NA				See MW-20B boring log for Lithologic Description		
					10				10.0	
					20				20.0	
					30				30.0	
					40				40.0	
								The boring was terminated and the well was set at 41' bgs. The well was completed with a protective stickup which requires approximately 3 feet of additional casing above grade.		

LUMINANT

Luminant

Log of Boring: PDP-22

Martin Lake Steam Electric Station Tatum, TX	Completion Date:	9/9/2015	Drilling Method:	Sonic
	Drilling Company:	Walker-Hill Environmental	Borehole Diameter (in.):	6.5
PBW Project No. 5164B	Driller:	Timmy Beach	Total Depth (ft):	60
	Driller's License:	5814M	TOC Elevation (ft. AMSL):	
	Logged By:	Ryan Francis	Northing:	
	Sampling Method:	4"x10' Core barrel	Easting:	

Depth (ft)	Well Materials	Recovery (ft/ft)	USCS	Lithologic Description
0			SP	(0 - 3) Fine SAND, tan, dry, very soft, small iron concretions, grass roots
4		8.0/10.0	CL	(3 - 10) Sandy CLAY, red/orange mottled, dry, firm, moderate cementation, flat to subrounded, sharp contact
8				
12		10.0/10.0	CH	(10 - 20) Silty CLAY with minor sand, dry, firm, moderate cementation, flat to subrounded, medium to high plasticity, micro laminated structure, increasing sand content with depth, transition from red/gray at 10' to tan at 20'
16				
20		10.0/10.0	SM	(20 - 28) Sandy SILT, gray and tan, dry, firm, moderate cementation, flat to subrounded, grass lense (fill), transition to gray at 26'
24				
28				(28 - 30) Silty SAND, iron-rich, dry, soft, weak cementation, subrounded, sharp contact
32		10.0/10.0	SC	(30 - 53) SAND, gray with small streaks and iron at 32', moist to wet, soft, moderate plasticity at 30', transition to low plasticity at 40', minor clay content
36				
40		10.0/10.0	CL	(53 - 60) Silty CLAY, gray, dry, firm, moderate cementation, dry, flat, transition to very hard gray/dark gray clay at 56'
44				
48				
52				
56				
60				

PBW

Pastor, Behling & Wheeler, LLC
 2201 Double Creek Dr., Suite 4004
 Round Rock, TX 78664
 Tel (512) 671-3434 Fax (512) 671-3446

Notes:

1. This log should not be used separately from the report to which it is attached.

Well Materials

(0-35) Casing, 2" Sch 40 FJT PVC
 (35-60) Screen, 2" Sch 40 FJT PVC, 0.010" slot

Annular Materials

(0'-31') Grout
 (31'-33') Bentonite pellets
 (33'-60') 20/40 sand

Luminant

Log of Boring: PDP-23

Martin Lake Steam Electric Station Tatum, TX	Completion Date:	9/10/2015	Drilling Method:	Sonic
	Drilling Company:	Walker-Hill Environmental	Borehole Diameter (in.):	6.5
PBW Project No. 5164B	Driller:	Timmy Beach	Total Depth (ft):	50
	Driller's License:	5814M	TOC Elevation (ft. AMSL):	
	Logged By:	Ryan Francis	Northing:	
	Sampling Method:	4"x10' Core barrel	Easting:	

Depth (ft)	Well Materials	Recovery (ft/ft)	USCS	Lithologic Description
0				
4		10.0/10.0		
8				
12				
16		10.0/10.0		(0 - 30) Sandy CLAY, brown to red to tan, dry, soft to firm, weak cementation, iron rich at 5', none to moderate plasticity, black mottling and some organics present at 10', iron banding and iron nodules with increasing sand content at 16', microlaminated iron rich banded gray, tan, and red sandy clay (21' - 30')
20			CL	
24		10.0/10.0		
28				
32				
36		10.0/10.0		(30 - 39) CLAY, gray, micro laminated, minor sand content, dry, firm to hard, weak to moderate cementation, low plasticity
40				(39 - 41) Sandy CLAY, light gray, dry, firm, weak cementation, medium plasticity
44			SC	(41 - 44) Clayey SAND, wet, soft, weak cementation, subrounded, medium to high plasticity
48		10.0/10.0	CL	(44 - 50) Sandy CLAY, dark gray, dry, hard, moderate cementation
52				

PBW

Pastor, Behling & Wheeler, LLC
 2201 Double Creek Dr., Suite 4004
 Round Rock, TX 78664
 Tel (512) 671-3434 Fax (512) 671-3446

Notes:

1. This log should not be used separately from the report to which it is attached.

Well Materials

(0-35) Casing, 2" Sch 40 FJT PVC
 (35-45) Screen, 2" Sch 40 FJT PVC, 0.010" slot

Annular Materials

(0'-31') Grout
 (31'-33') Bentonite pellets
 (33'-45') 20/40 sand

Luminant

Log of Boring: PDP-24

Martin Lake Steam Electric Station Tatum, TX	Completion Date:	9/11/2015	Drilling Method:	Sonic
	Drilling Company:	Walker-Hill Environmental	Borehole Diameter (in.):	6.5
PBW Project No. 5164B	Driller:	Timmy Beach	Total Depth (ft):	50
	Driller's License:	5814M	TOC Elevation (ft. AMSL):	
	Logged By:	Ryan Francis	Northing:	
	Sampling Method:	4"x10' Core barrel	Easting:	

Depth (ft)	Well Materials	Recovery (ft/ft)	USCS	Lithologic Description
0				
4		8.0/10.0		
8				
12				
16		7.0/10.0	CL	(0 - 30) Sandy CLAY, red and tan mottling, fine sand, dry to moist, firm, weak cementation, low to medium plasticity, occasional black inclusions, minor very fine sand content in gray and orange clay and high plasticity (20'-30')
20				
24		10.0/10.0		
28				
32				
36		10.0/10.0	CL/SC	(30 - 45) Sandy CLAY/Clayey SAND, gray, moist to wet, very fine grained, firm, weak cementation, medium plasticity, softens and increasing wetness with depth (35'-39'), brown with increased iron content (39'-42'), dark gray, dry, and none to low plasticity (39'-45')
40				
44		10.0/10.0	SP	(45 - 47) Clayey SAND, wet, soft, weak cementation, medium to high plasticity
48			CL	(47 - 50) Sandy CLAY, dark gray, fine grained, dry, firm to hard, weak cementation
52				

PBW

Pastor, Behling & Wheeler, LLC
2201 Double Creek Dr., Suite 4004
Round Rock, TX 78664
Tel (512) 671-3434 Fax (512) 671-3446

Notes:

1. This log should not be used separately from the report to which it is attached.

Well Materials

(0-30) Casing, 2" Sch 40 FJT PVC
(30-40) Screen, 2" Sch 40 FJT PVC, 0.010" slot

Annular Materials

(0'-26') Grout
(26'-28') Bentonite pellets
(28'-40') 20/40 sand

Luminant

Log of Boring: PDP-25

Martin Lake Steam Electric Station Tatum, TX	Completion Date:	9/11/2015	Drilling Method:	Sonic
	Drilling Company:	Walker-Hill Environmental	Borehole Diameter (in.):	6.5
PBW Project No. 5164B	Driller:	Timmy Beach	Total Depth (ft):	70
	Driller's License:	5814M	TOC Elevation (ft. AMSL):	
	Logged By:	Ryan Francis	Northing:	
	Sampling Method:	4"x10' Core barrel	Easting:	

Depth (ft)	Well Materials	Recovery (ft/ft)	USCS	Lithologic Description
0				
4		10.0/10.0		
8				
12				
16		10.0/10.0		
20				
24		10.0/10.0	CL	(0 - 44) Sandy CLAY, red to gray and tan, very fine grained, dry to moist, firm, low to medium plasticity, weak to moderate cementation, micro laminated, minor organics, variable sand content with depth, high plasticity and very low sand content (22'-23'), higher sand content and high iron content with occasional subrounded pebbles (27'-30'), red, orange, tan, and gray mottling (30'-44')
28				
32				
36		10.0/10.0		
40				
44		10.0/10.0		
48				
52				
56		10.0/10.0	SP	(44 - 68) Clayey SAND, gray, moist, soft to firm, minor orange streaking, low plasticity, weak cementation, subrounded, minor wet and soft clay zone (62'-64')
60				
64		10.0/10.0		
68				
72			CL	(68 - 70) CLAY, black, minor silt, dry, very hard, moderate cementation, smooth shiny surface when fractured

PBW

Pastor, Behling & Wheeler, LLC
 2201 Double Creek Dr., Suite 4004
 Round Rock, TX 78664
 Tel (512) 671-3434 Fax (512) 671-3446

Notes:

1. This log should not be used separately from the report to which it is attached.

Well Materials

(0-50) Casing, 2" Sch 40 FJT PVC
 (50-60) Screen, 2" Sch 40 FJT PVC, 0.010" slot

Annular Materials

(0'-46') Grout
 (46'-48') Bentonite pellets
 (48'-60') 20/40 sand

Luminant

Log of Boring: PDP-26

Martin Lake Steam Electric Station Tatum, TX	Completion Date:	9/9/2015	Drilling Method:	Sonic
	Drilling Company:	Walker-Hill Environmental	Borehole Diameter (in.):	6.5
PBW Project No. 5164B	Driller:	Timmy Beach	Total Depth (ft):	50
	Driller's License:	5814M	TOC Elevation (ft. AMSL):	
	Logged By:	Ryan Francis	Northing:	
	Sampling Method:	4"x10' Core barrel	Easting:	

Depth (ft)	Well Materials	Recovery (ft/ft)	USCS	Lithologic Description
0			SP	(0 - 3) SAND, tan, dry, very soft, weak cementation
4		10.0/10.0	SC	(3 - 6) Clayey SAND, dry, firm, black lignite present
8			CL	(6 - 9) CLAY with minor sand, red, moist, firm, medium plasticity, smear zone black lignite
12		10.0/10.0	SC	(9 - 16) Clayey SAND, tan, moist, soft, low plasticity, more clay content with depth
16				
20		10.0/10.0		
24				
28		10.0/10.0	CL	(16 - 40) CLAY, tan, micro laminated orange and gray, moist, soft, medium plasticity, dry and silty clay (19'-27'), micro laminated gray and dark gray (27'-36'), increasing sand content (30'-36'), organics layer (36.5'-37'), high iron content (39'-40')
32				
36		10.0/10.0		
40				
44		10.0/10.0	SP	(40 - 48) SAND, tan, medium, moist to wet, soft, subrounded
48			CL	(48 - 50) CLAY, gray, micro laminated, dry, firm, moderate cementation
52				

PBW

Pastor, Behling & Wheeler, LLC
 2201 Double Creek Dr., Suite 4004
 Round Rock, TX 78664
 Tel (512) 671-3434 Fax (512) 671-3446

Notes:

1. This log should not be used separately from the report to which it is attached.

Well Materials

(0-39) Casing, 2" Sch 40 FJT PVC
 (39-49) Screen, 2" Sch 40 FJT PVC, 0.010" slot



Annular Materials

(0'-35') Grout
 (35'-37') Bentonite pellets
 (37'-49') 20/40 sand

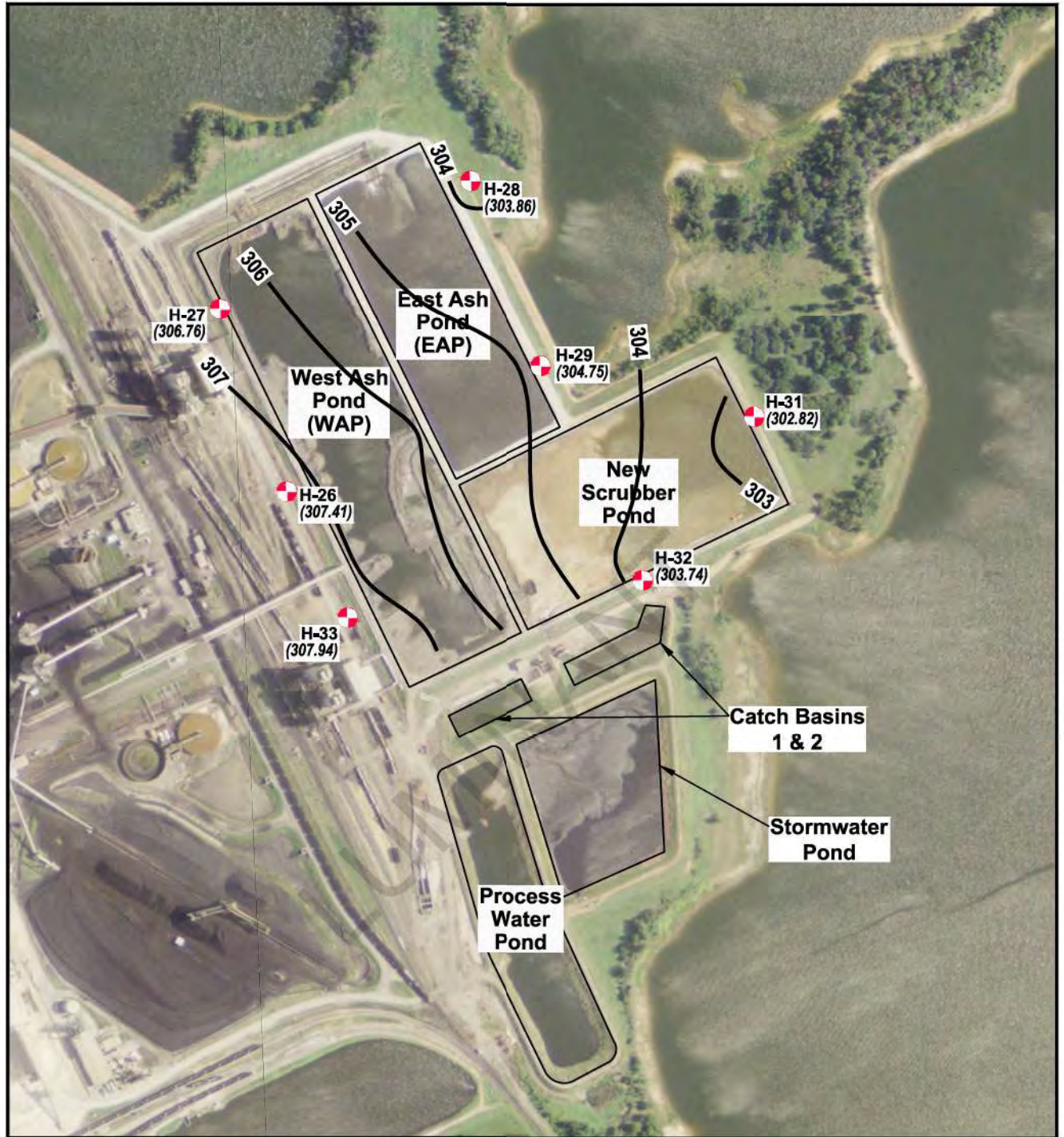
APPENDIX F3 – MAPS OF THE DIRECTION OF GROUNDWATER FLOW



EXPLANATION

-  CCR Monitoring Well Location
-  (308.70) Groundwater Potentiometric Surface (ft. MSL)
-  - 308 - Groundwater Potentiometric Surface Contour (C.I. = 1 ft.)

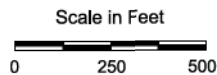

**MARTIN LAKE STEAM ELECTRIC STATION
TATUM, TEXAS**

Figure 1

**ASH POND AREA - GROUNDWATER
ZONE B POTENTIOMETRIC SURFACE
MAP - OCTOBER 21-22, 2015**

PROJECT: 5164B	BY: AJD	REVISIONS
DATE: SEPT., 2017	CHECKED: PJB	

PASTOR, BEHLING & WHEELER, LLC
CONSULTING ENGINEERS AND SCIENTISTS

SOURCE: Imagery from www.tnris.gov, Rusk County, aerial photographs, 2012.

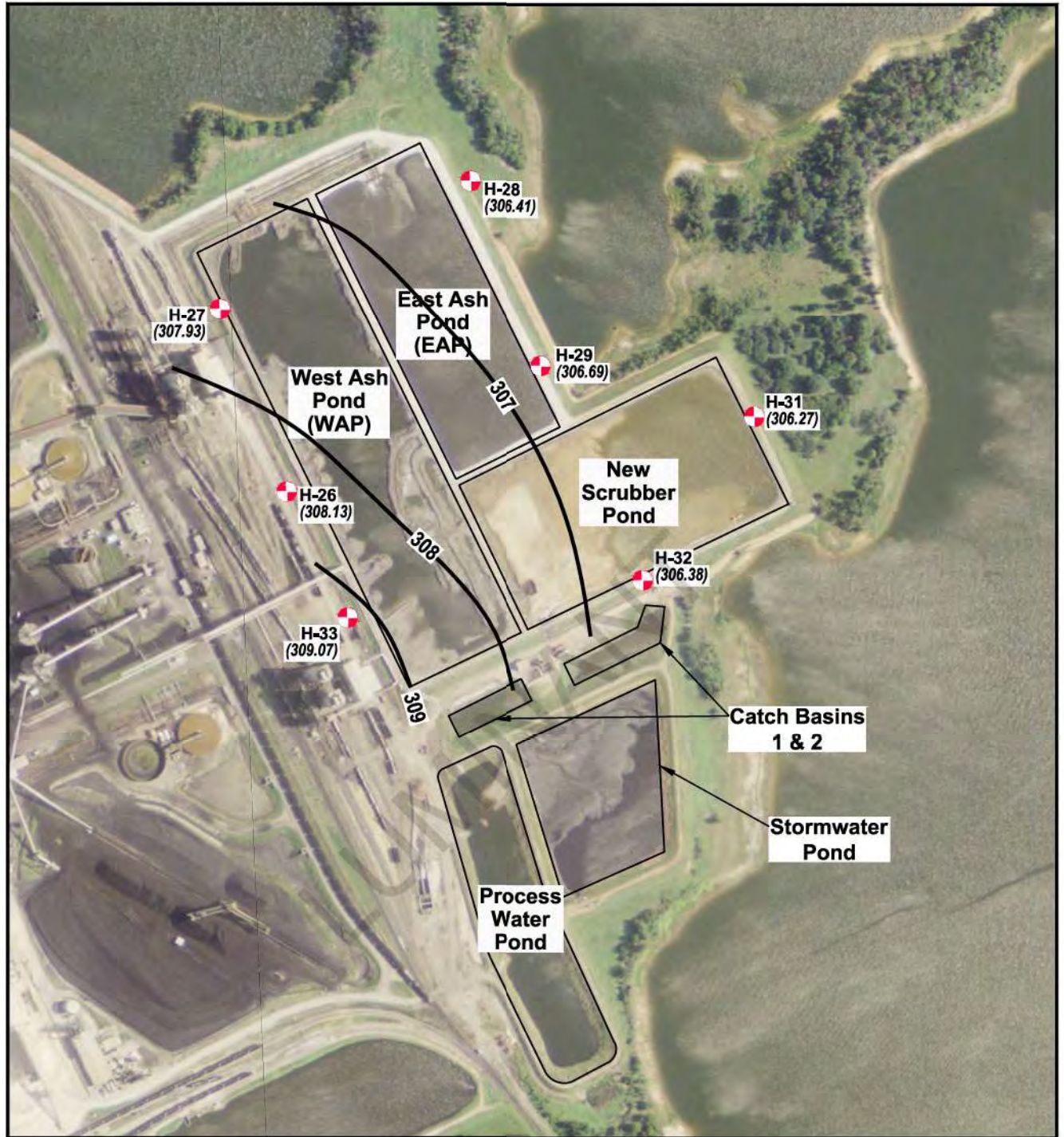

EXPLANATION

-  CCR Monitoring Well Location
- (308.70)* Groundwater Potentiometric Surface (ft. MSL)
- 308 —** Groundwater Potentiometric Surface Contour (C.I. = 1 ft.)

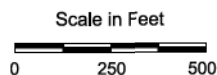

**MARTIN LAKE STEAM ELECTRIC STATION
TATUM, TEXAS**

Figure 2

**ASH POND AREA - GROUNDWATER
ZONE B POTENTIOMETRIC
SURFACE MAP - DECEMBER 14, 2015**

PROJECT: 5164B	BY: AJD	REVISIONS
DATE: SEPT., 2017	CHECKED: PJB	

PASTOR, BEHLING & WHEELER, LLC
CONSULTING ENGINEERS AND SCIENTISTS

SOURCE: Imagery from www.tnris.gov, Rusk County, aerial photographs, 2012.

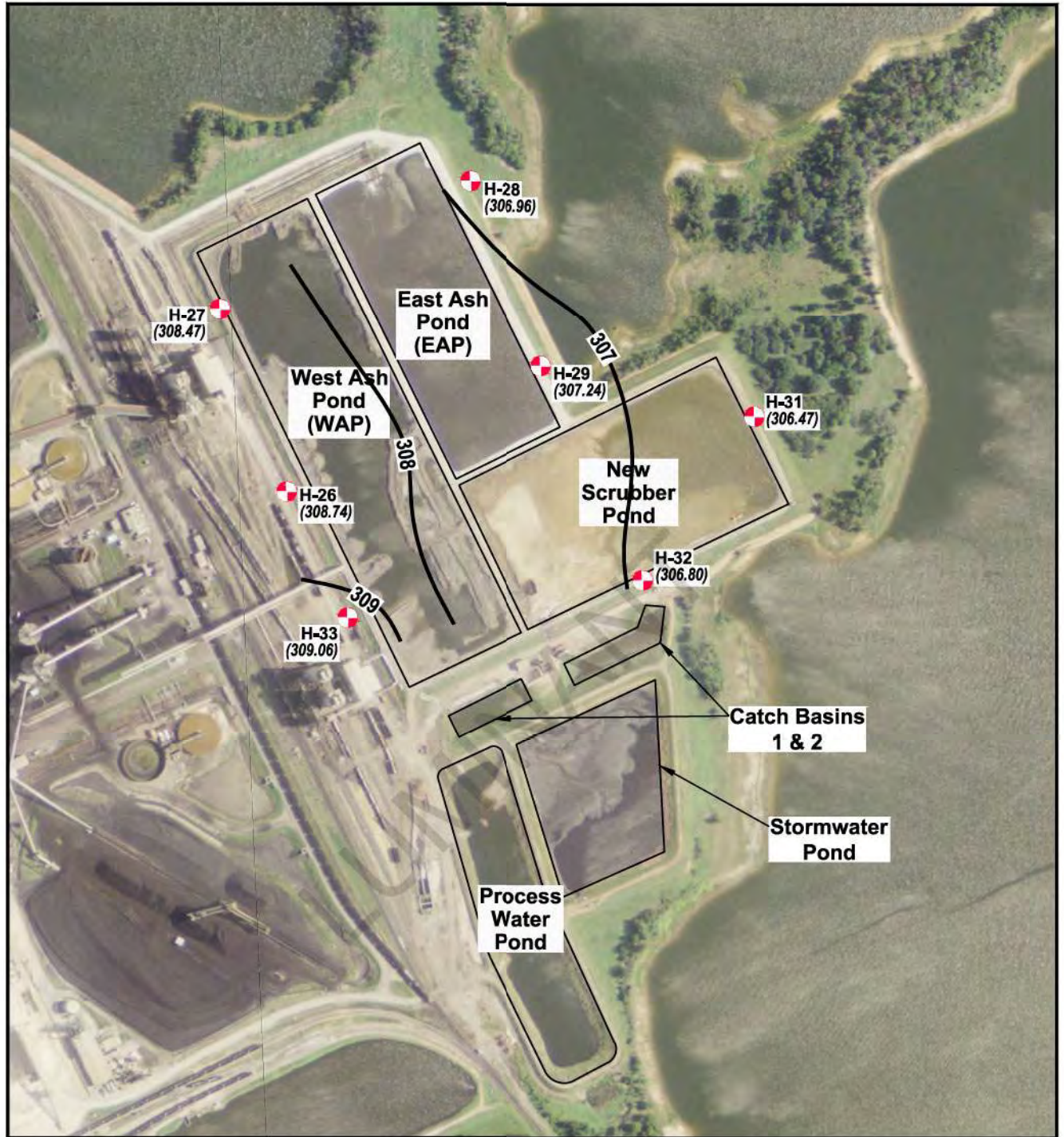

EXPLANATION

-  CCR Monitoring Well Location
- (308.70)** Groundwater Potentiometric Surface (ft. MSL)
- 308 —** Groundwater Potentiometric Surface Contour (C.I. = 1 ft.)

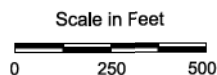

SOURCE: Imagery from www.tnris.gov, Rusk County, aerial photographs, 2012.

**MARTIN LAKE STEAM ELECTRIC STATION
TATUM, TEXAS**

Figure 3

**ASH POND AREA - GROUNDWATER
ZONE B POTENTIOMETRIC
SURFACE MAP - FEBRUARY 25, 2016**

PROJECT: 5164B	BY: AJD	REVISIONS
DATE: SEPT., 2017	CHECKED: PJB	

PASTOR, BEHLING & WHEELER, LLC
CONSULTING ENGINEERS AND SCIENTISTS

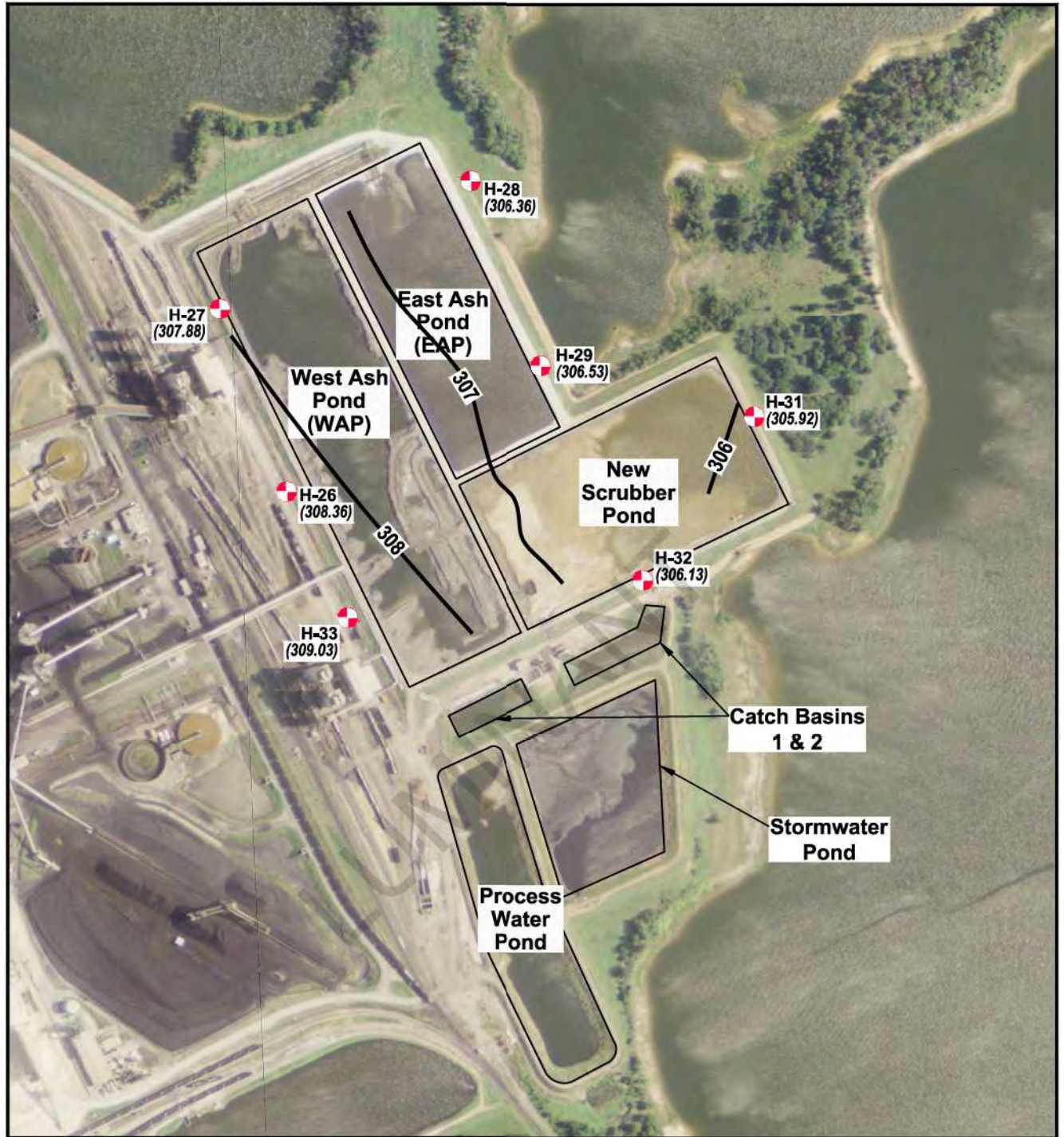

EXPLANATION

-  CCR Monitoring Well Location
- (308.70)** Groundwater Potentiometric Surface (ft. MSL)
- 308 —** Groundwater Potentiometric Surface Contour (C.I. = 1 ft.)

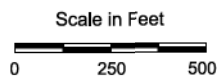

MARTIN LAKE STEAM ELECTRIC STATION
TATUM, TEXAS

Figure 4

**ASH POND AREA - GROUNDWATER
ZONE B POTENTIOMETRIC
SURFACE MAP - APRIL 5, 2016**

PROJECT: 5164B	BY: AJD	REVISIONS
DATE: SEPT., 2017	CHECKED: PJB	

PASTOR, BEHLING & WHEELER, LLC
CONSULTING ENGINEERS AND SCIENTISTS

SOURCE: Imagery from www.tnris.gov, Rusk County, aerial photographs, 2012.

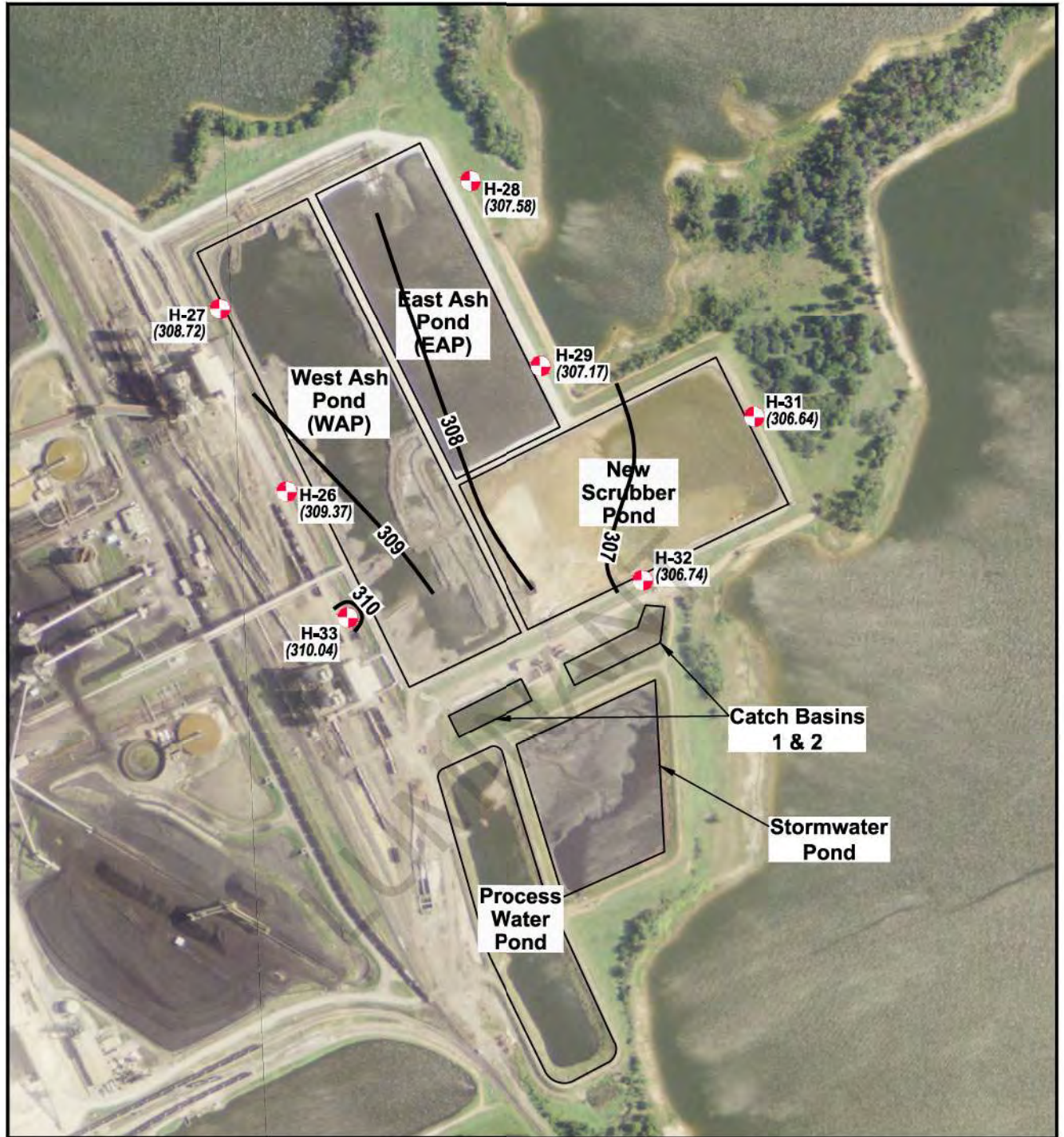

EXPLANATION

-  CCR Monitoring Well Location
- (308.70)* Groundwater Potentiometric Surface (ft. MSL)
- 308 —** Groundwater Potentiometric Surface Contour (C.I. = 1 ft.)

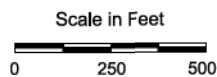

SOURCE: Imagery from www.tnris.gov, Rusk County, aerial photographs, 2012.

**MARTIN LAKE STEAM ELECTRIC STATION
TATUM, TEXAS**

Figure 5

**ASH POND AREA - GROUNDWATER
ZONE B POTENTIOMETRIC
SURFACE MAP - JUNE 6, 2016**

PROJECT: 5164B	BY: AJD	REVISIONS
DATE: SEPT., 2017	CHECKED: PJB	

PASTOR, BEHLING & WHEELER, LLC
CONSULTING ENGINEERS AND SCIENTISTS

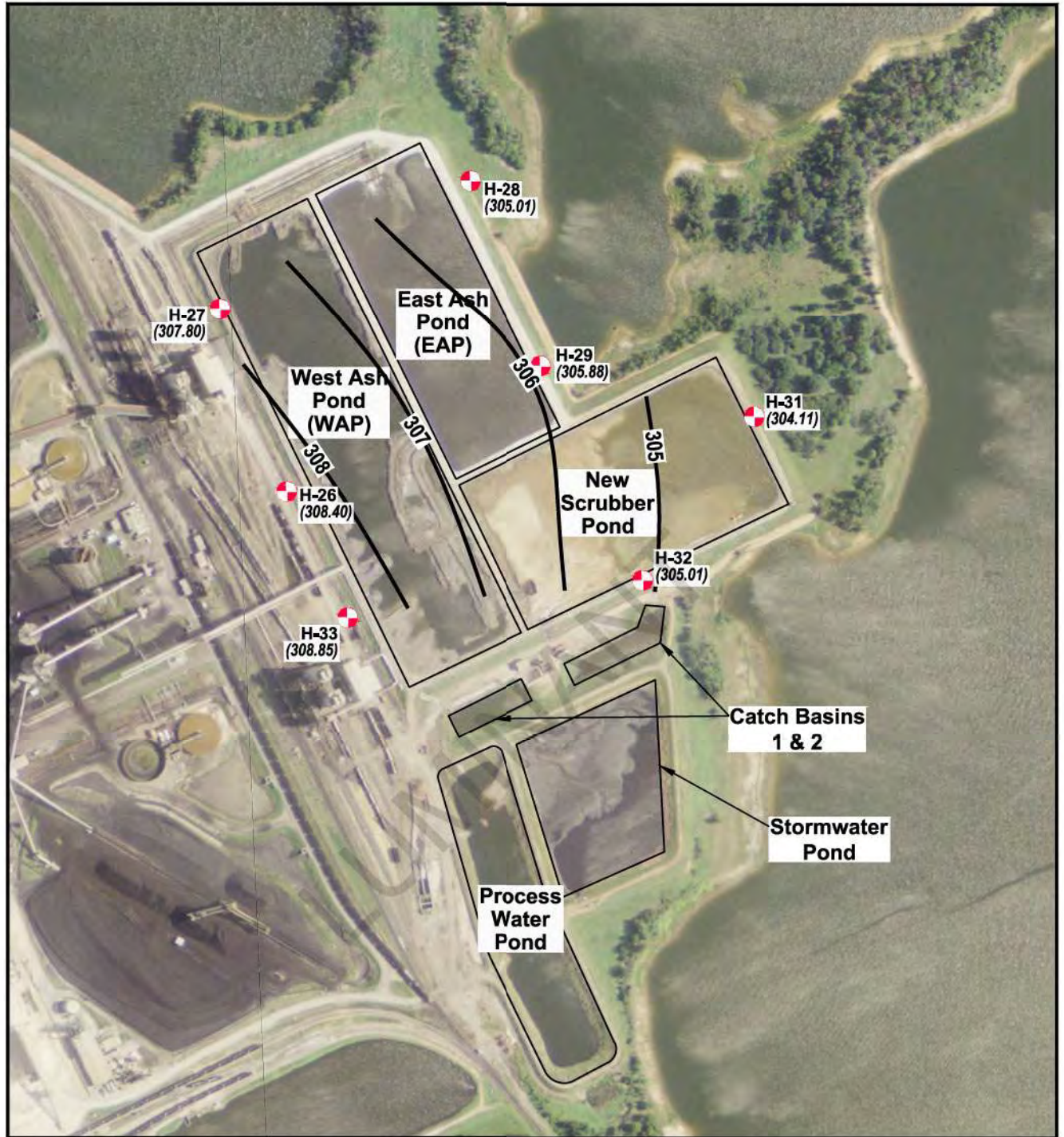

EXPLANATION

-  CCR Monitoring Well Location
- (308.70)* Groundwater Potentiometric Surface (ft. MSL)
- 308 —** Groundwater Potentiometric Surface Contour (C.I. = 1 ft.)

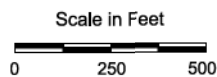

**MARTIN LAKE STEAM ELECTRIC STATION
TATUM, TEXAS**

Figure 6

**ASH POND AREA - GROUNDWATER
ZONE B POTENTIOMETRIC
SURFACE MAP - AUGUST 9, 2016**

PROJECT: 5164B	BY: AJD	REVISIONS
DATE: SEPT., 2017	CHECKED: PJB	

PASTOR, BEHLING & WHEELER, LLC
CONSULTING ENGINEERS AND SCIENTISTS

SOURCE: Imagery from www.tnris.gov, Rusk County, aerial photographs, 2012.

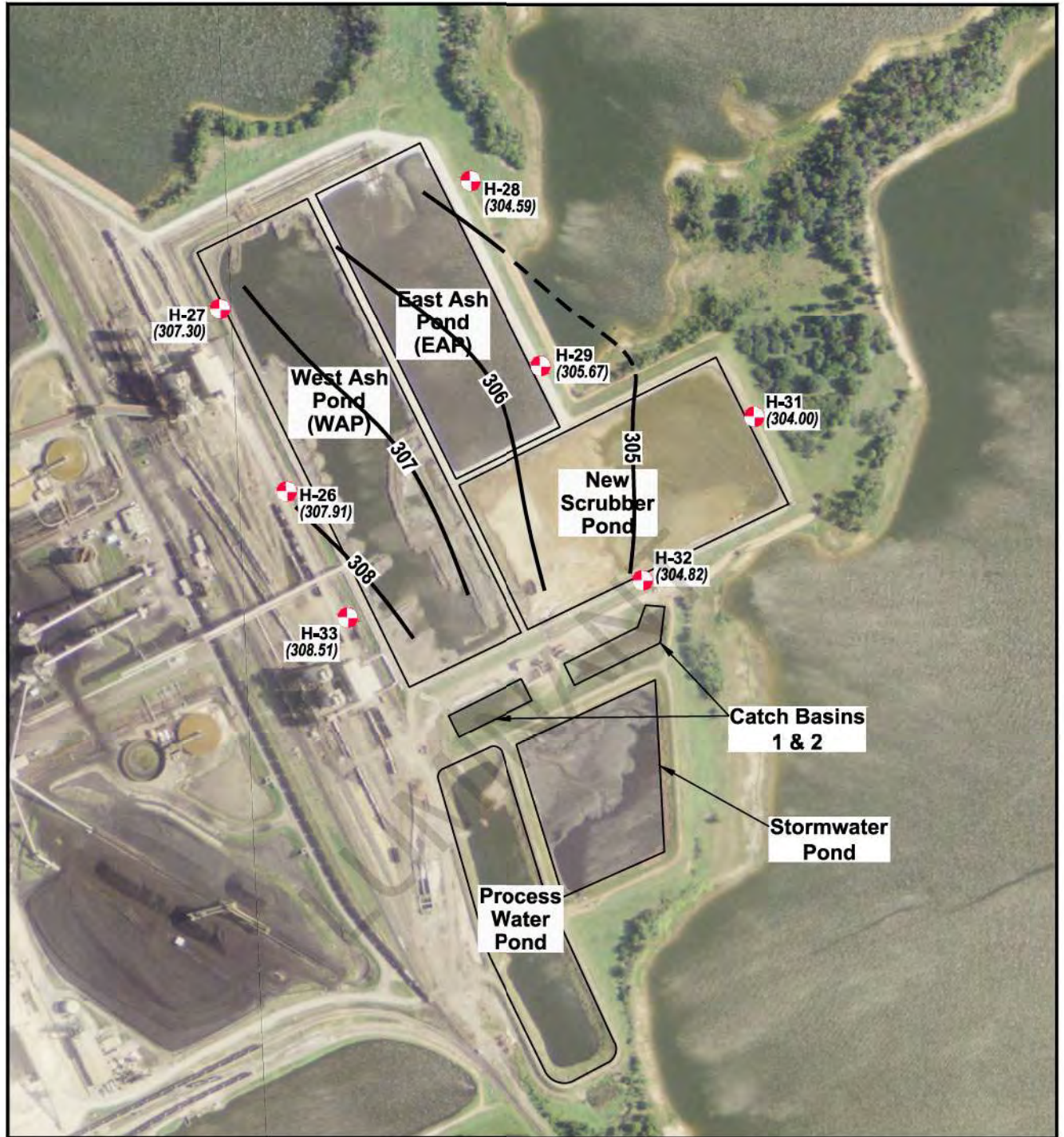

EXPLANATION

-  CCR Monitoring Well Location
- (308.70)* Groundwater Potentiometric Surface (ft. MSL)
- 308 —** Groundwater Potentiometric Surface Contour (C.I. = 1 ft.)

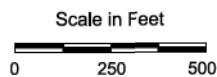

**MARTIN LAKE STEAM ELECTRIC STATION
TATUM, TEXAS**

Figure 7

**ASH POND AREA - GROUNDWATER
ZONE B POTENTIOMETRIC
SURFACE MAP - OCTOBER 17, 2016**



PROJECT: 5164B	BY: AJD	REVISIONS
DATE: SEPT., 2017	CHECKED: PJB	

PASTOR, BEHLING & WHEELER, LLC
CONSULTING ENGINEERS AND SCIENTISTS

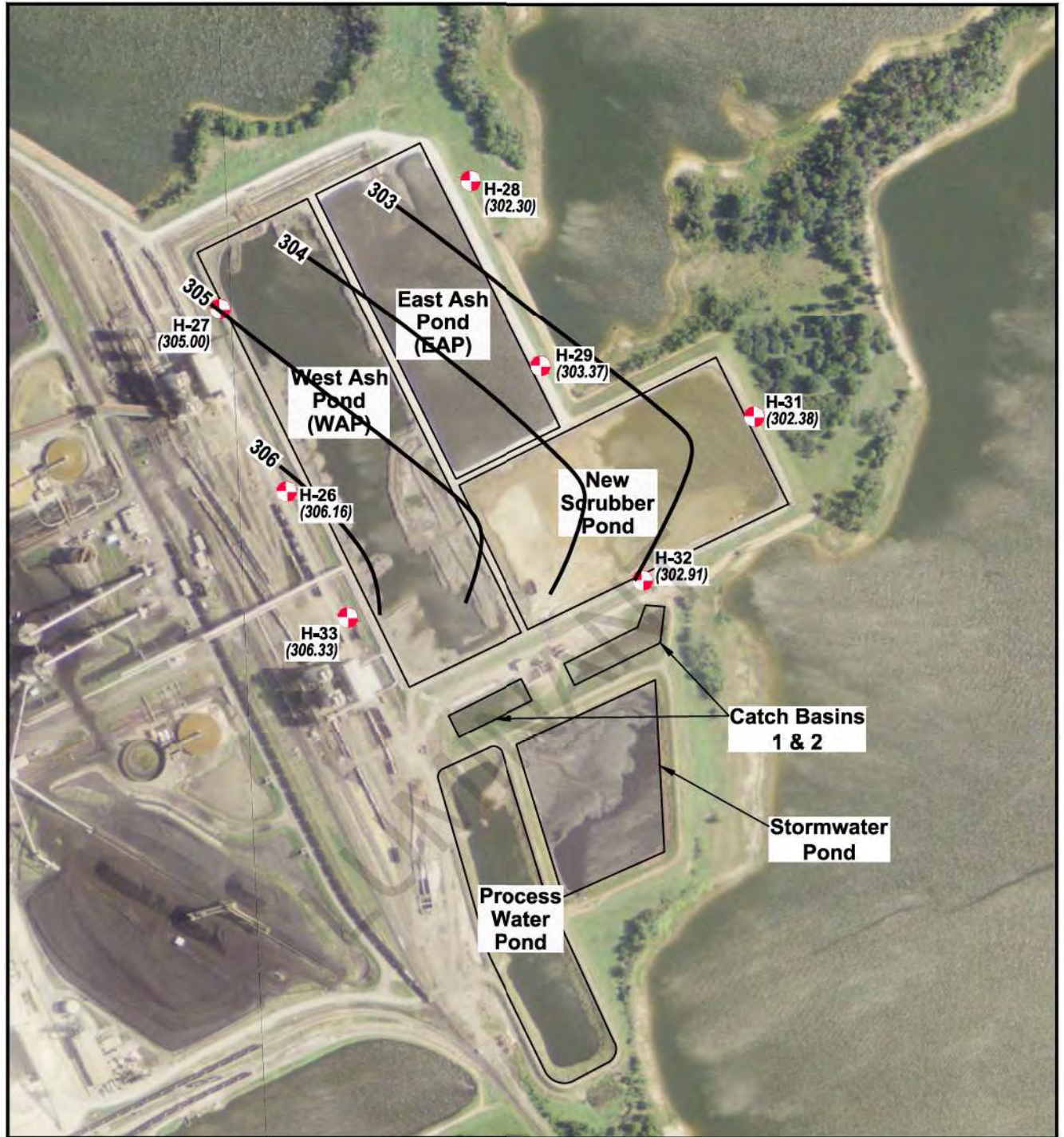
SOURCE: Imagery from www.tnris.gov, Rusk County, aerial photographs, 2012.



EXPLANATION

-  CCR Monitoring Well Location
-  (308.70) Groundwater Potentiometric Surface (ft. MSL)
-  308 Groundwater Potentiometric Surface Contour (C.I. = 1 ft.)

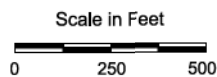

**MARTIN LAKE STEAM ELECTRIC STATION
TATUM, TEXAS**

Figure 8

**ASH POND AREA - GROUNDWATER
ZONE B POTENTIOMETRIC
SURFACE MAP - DECEMBER 11, 2016**

PROJECT: 5164B	BY: AJD	REVISIONS
DATE: SEPT., 2017	CHECKED: PJB	



PASTOR, BEHLING & WHEELER, LLC
CONSULTING ENGINEERS AND SCIENTISTS

SOURCE: Imagery from www.tnris.gov, Rusk County, aerial photographs, 2012.



Last Edited By: pmh2024 Date: 2019-06-28 Time: 12:45:32 PM | Printed By: P:\cibook Date: 2019-07-15 Time: 11:20:29 AM
 Path: I:\e\ehana.golder\gib\total\Projects - Round\19122449 - Luminant\Martin Lake | File Name: FIG 3 - POT Surface Map-Ash Pond Area (May, 2019).dwg

LEGEND

-  DOWNGRADIENT CCR MONITORING WELL
-  UPGRADIENT CCR MONITORING WELL
- (308.70)** GROUNDWATER POTENTIOMETRIC SURFACE (FT MSL)
- 308 —** GROUNDWATER POTENTIOMETRIC SURFACE CONTOUR (C.I. = 1 FT)

CLIENT
LUMINANT

PROJECT
MARTIN LAKE STEAM ELECTRIC STATION
TATUM, TEXAS

TITLE
**ASH POND AREA
POTENTIOMETRIC SURFACE MAP
MAY 14, 2019**

CONSULTANT	YYYY-MM-DD	2019-06-24
DESIGNED		AJD
PREPARED		AJD
REVIEWED		WFV
APPROVED		WFV





REFERENCE(S)
BASE MAP TAKEN FROM GOOGLE EARTH, IMAGERY DATED 4/6/17.

PROJECT NO. 19122449 REV. 0 FIGURE 6

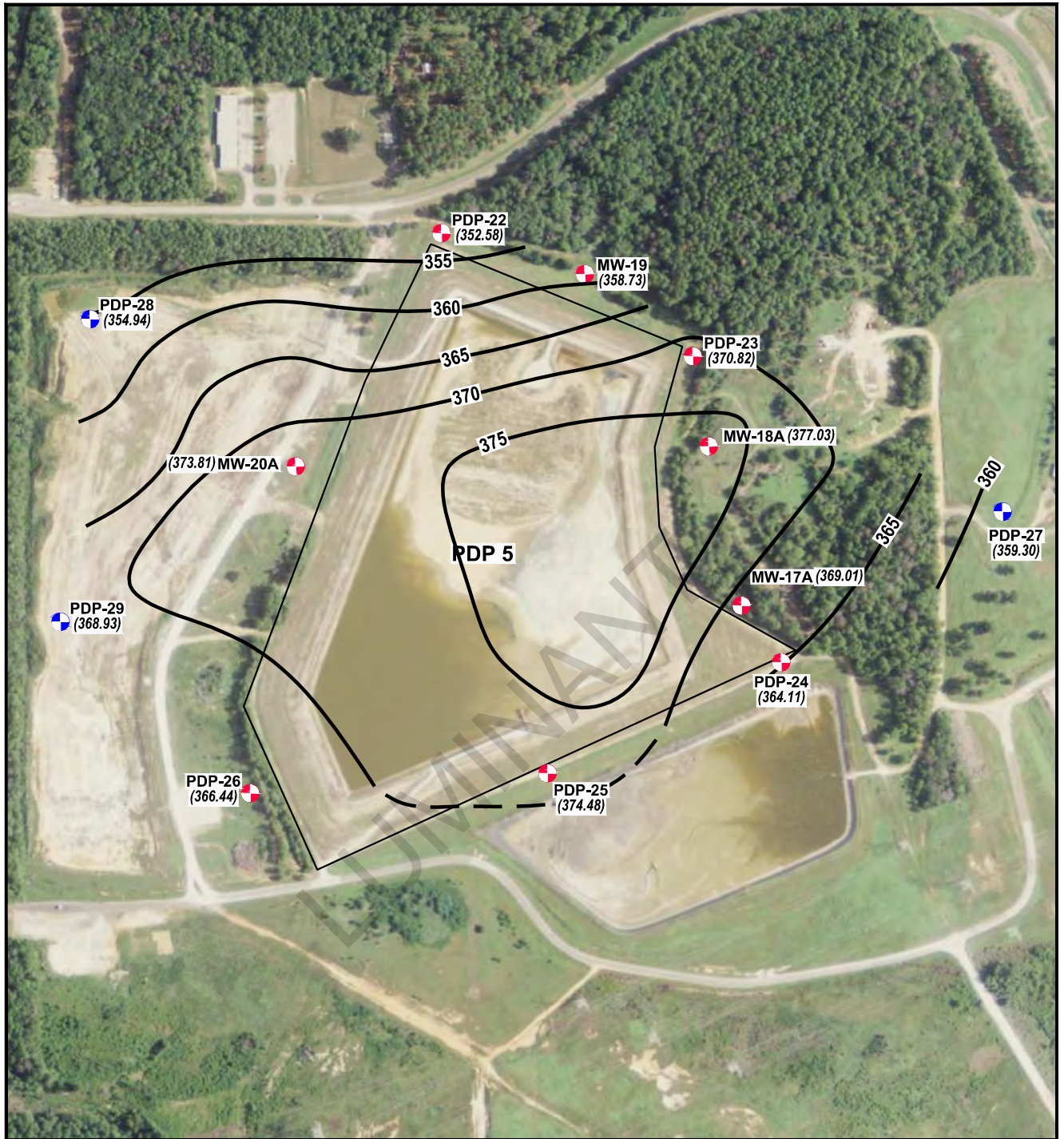
IF THIS MEASUREMENT DOES NOT MATCH WHAT IS SHOWN, THE SHEET SIZE HAS BEEN MODIFIED FROM ANS/A



EXPLANATION

-  CCR Monitoring Well Location
-  Non-CCR Monitoring Well Used to Further Evaluate Groundwater Flow Direction
- (374.34) Groundwater Potentiometric Surface (ft. MSL)
- 360 — Groundwater Potentiometric Surface Contour (C.I. = 5 ft.)

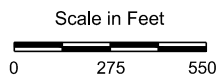

SOURCE:
Imagery from www.tnris.gov, Rusk County, aerial photographs, 2012.

**MARTIN LAKE STEAM ELECTRIC STATION
TATUM, TEXAS**



**PDP 5 - GROUNDWATER ZONE A
POTENTIOMETRIC SURFACE MAP
OCTOBER 20, 2015**

PROJECT: 5164B	BY: AJD	REVISIONS
DATE: SEPT., 2017	CHECKED: PJB	

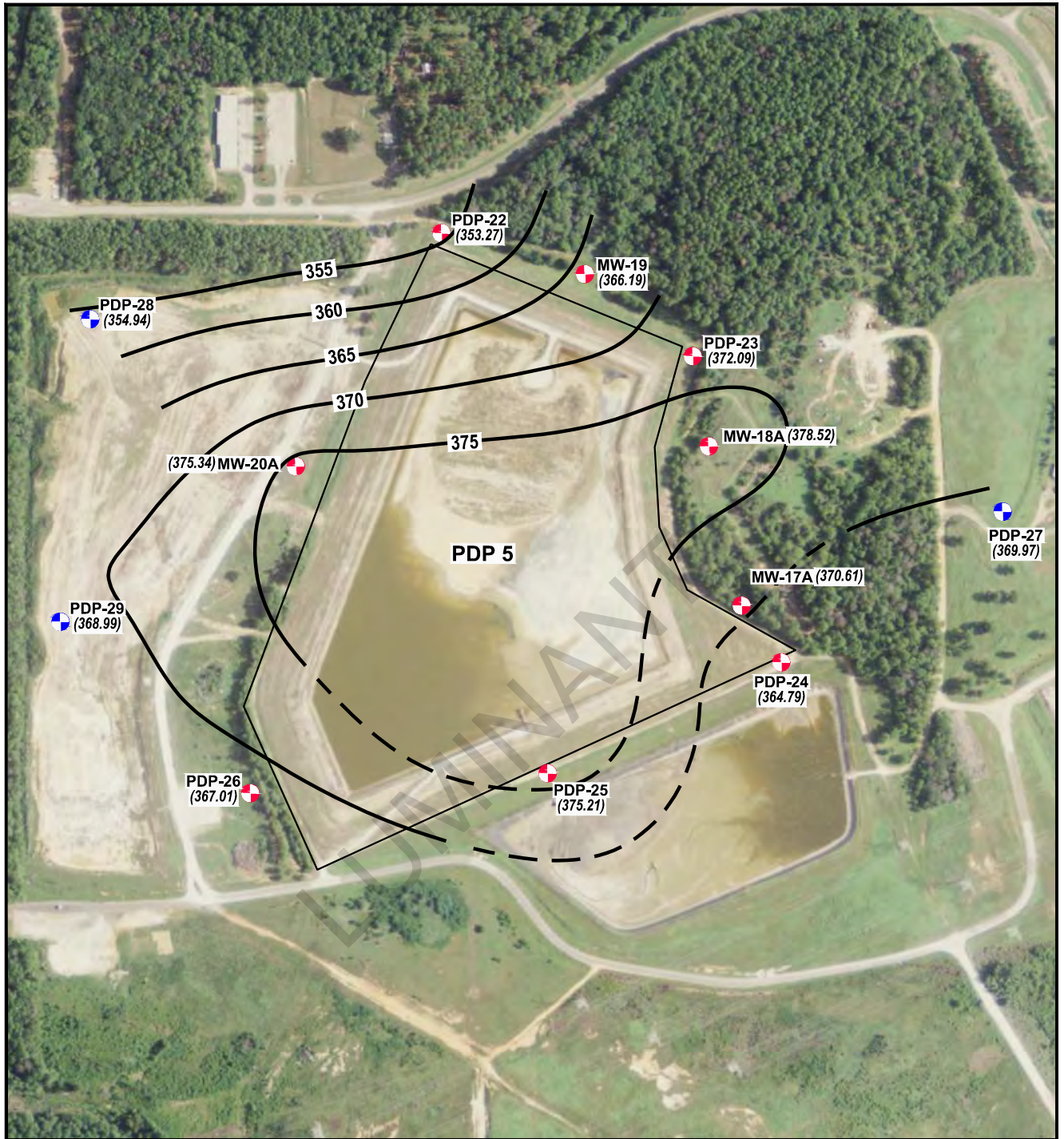
PASTOR, BEHLING & WHEELER, LLC
CONSULTING ENGINEERS AND SCIENTISTS



EXPLANATION

-  CCR Monitoring Well Location
-  Non-CCR Monitoring Well Used to Further Evaluate Groundwater Flow Direction
- (374.34) Groundwater Potentiometric Surface (ft. MSL)
- 360 — Groundwater Potentiometric Surface Contour (C.I. = 5 ft.)

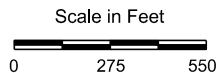

SOURCE:
Imagery from www.tnris.gov, Rusk County, aerial photographs, 2012.

**MARTIN LAKE STEAM ELECTRIC STATION
TATUM, TEXAS**



**PDP 5 - GROUNDWATER
ZONE A POTENTIOMETRIC
SURFACE MAP - DEC. 14, 2015**

PROJECT: 5164B	BY: AJD	REVISIONS
DATE: SEPT., 2017	CHECKED: PJB	

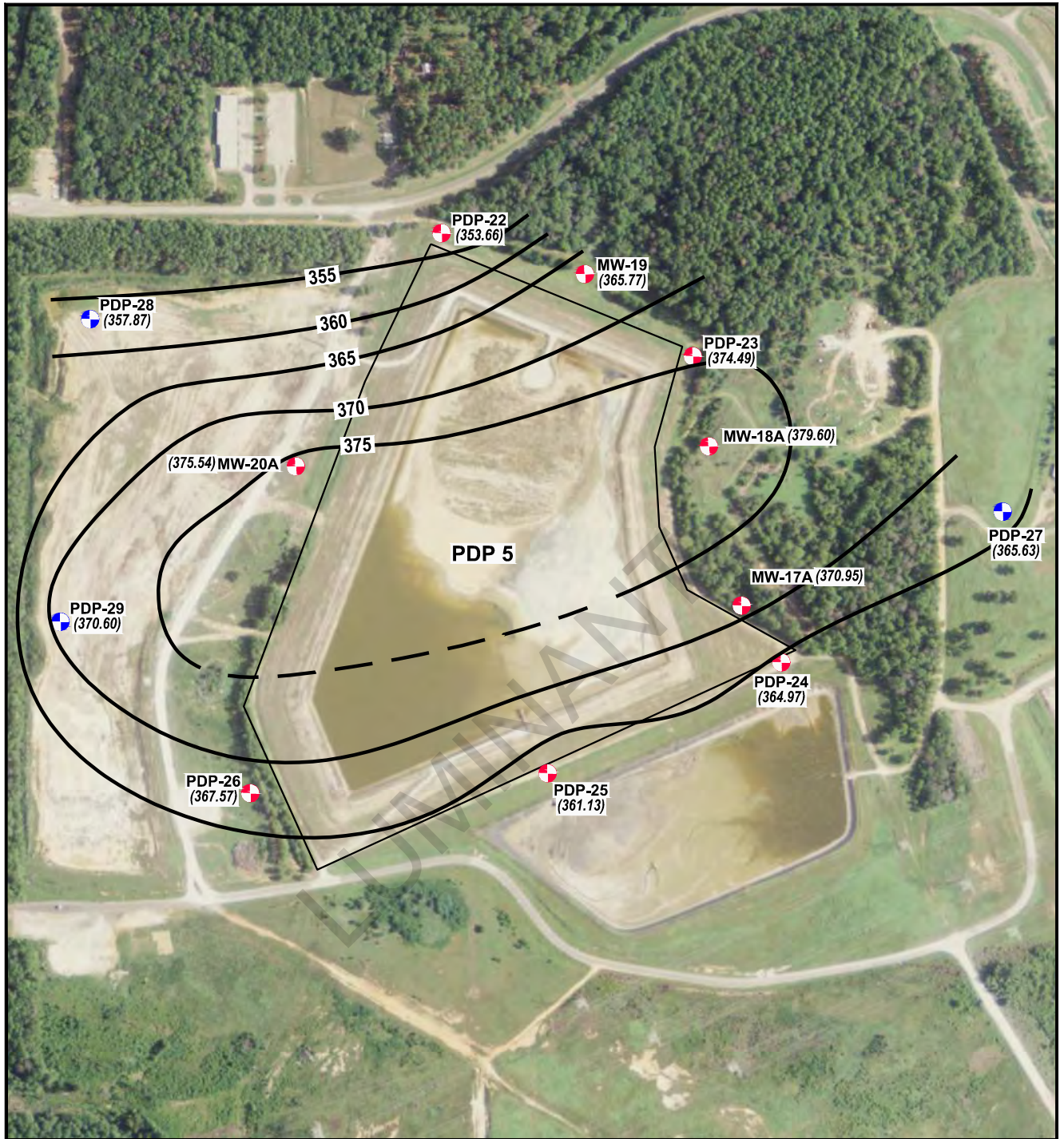
PASTOR, BEHLING & WHEELER, LLC
CONSULTING ENGINEERS AND SCIENTISTS



EXPLANATION

-  CCR Monitoring Well Location
-  Non-CCR Monitoring Well Used to Further Evaluate Groundwater Flow Direction
- (374.34) Groundwater Potentiometric Surface (ft. MSL)
- 360 — Groundwater Potentiometric Surface Contour (C.I. = 5 ft.)

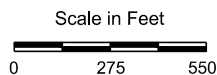

SOURCE:
Imagery from www.tnris.gov, Rusk County, aerial photographs, 2012.

**MARTIN LAKE STEAM ELECTRIC STATION
TATUM, TEXAS**



**PDP 5 - GROUNDWATER
ZONE A POTENTIOMETRIC
SURFACE MAP - FEB. 24, 2016**

PROJECT: 5164B	BY: AJD	REVISIONS
DATE: SEPT., 2017	CHECKED: PJB	

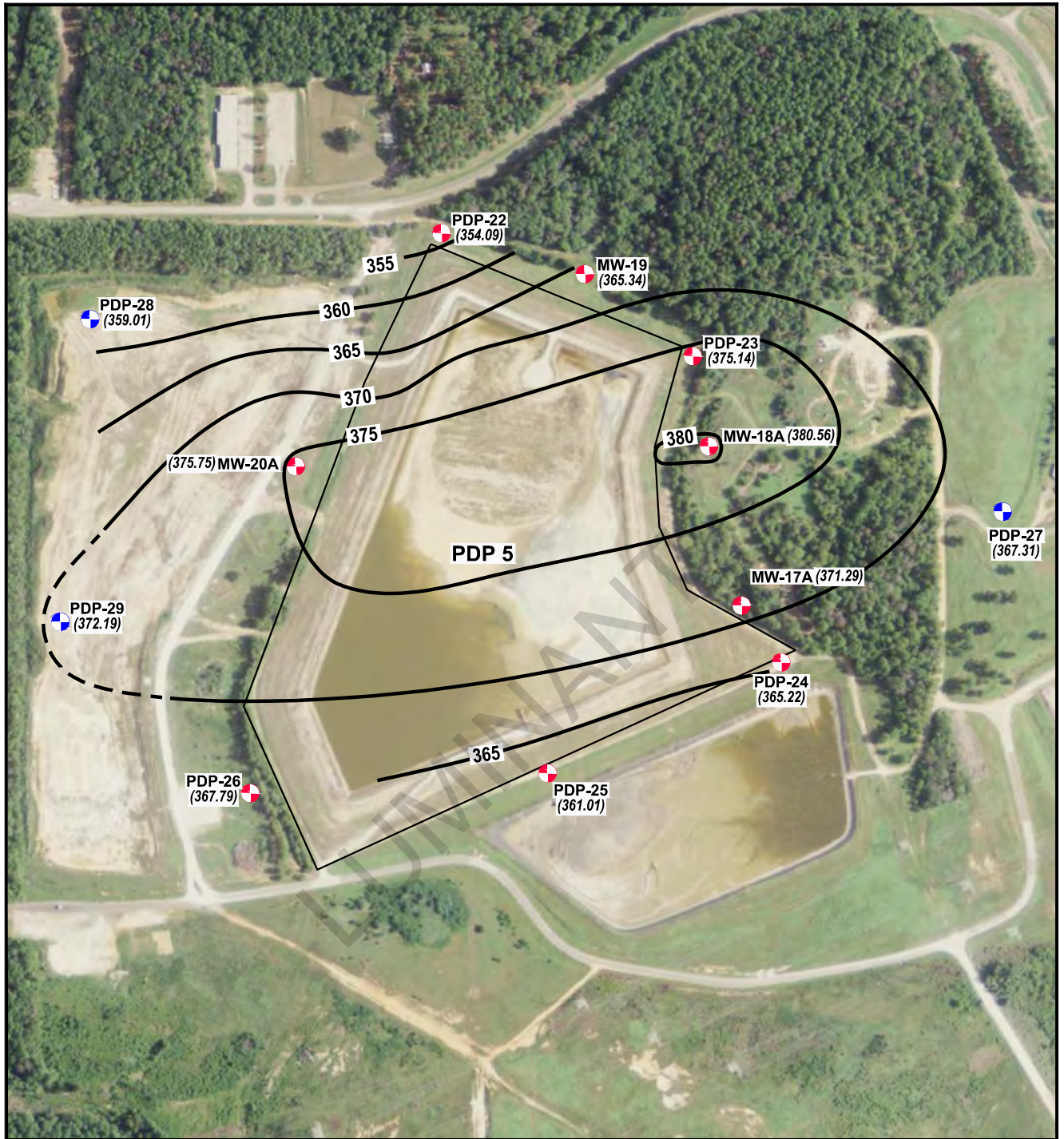
PASTOR, BEHLING & WHEELER, LLC
CONSULTING ENGINEERS AND SCIENTISTS



EXPLANATION

-  CCR Monitoring Well Location
-  Non-CCR Monitoring Well Used to Further Evaluate Groundwater Flow Direction
- (374.34) Groundwater Potentiometric Surface (ft. MSL)
- 360 — Groundwater Potentiometric Surface Contour (C.I. = 5 ft.)

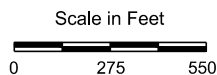

SOURCE:
Imagery from www.tnris.gov, Rusk County, aerial photographs, 2012.

**MARTIN LAKE STEAM ELECTRIC STATION
TATUM, TEXAS**



**PDP 5 - GROUNDWATER
ZONE A POTENTIOMETRIC
SURFACE MAP - APRIL 5, 2016**

PROJECT: 5164B	BY: AJD	REVISIONS
DATE: SEPT., 2017	CHECKED: PJB	

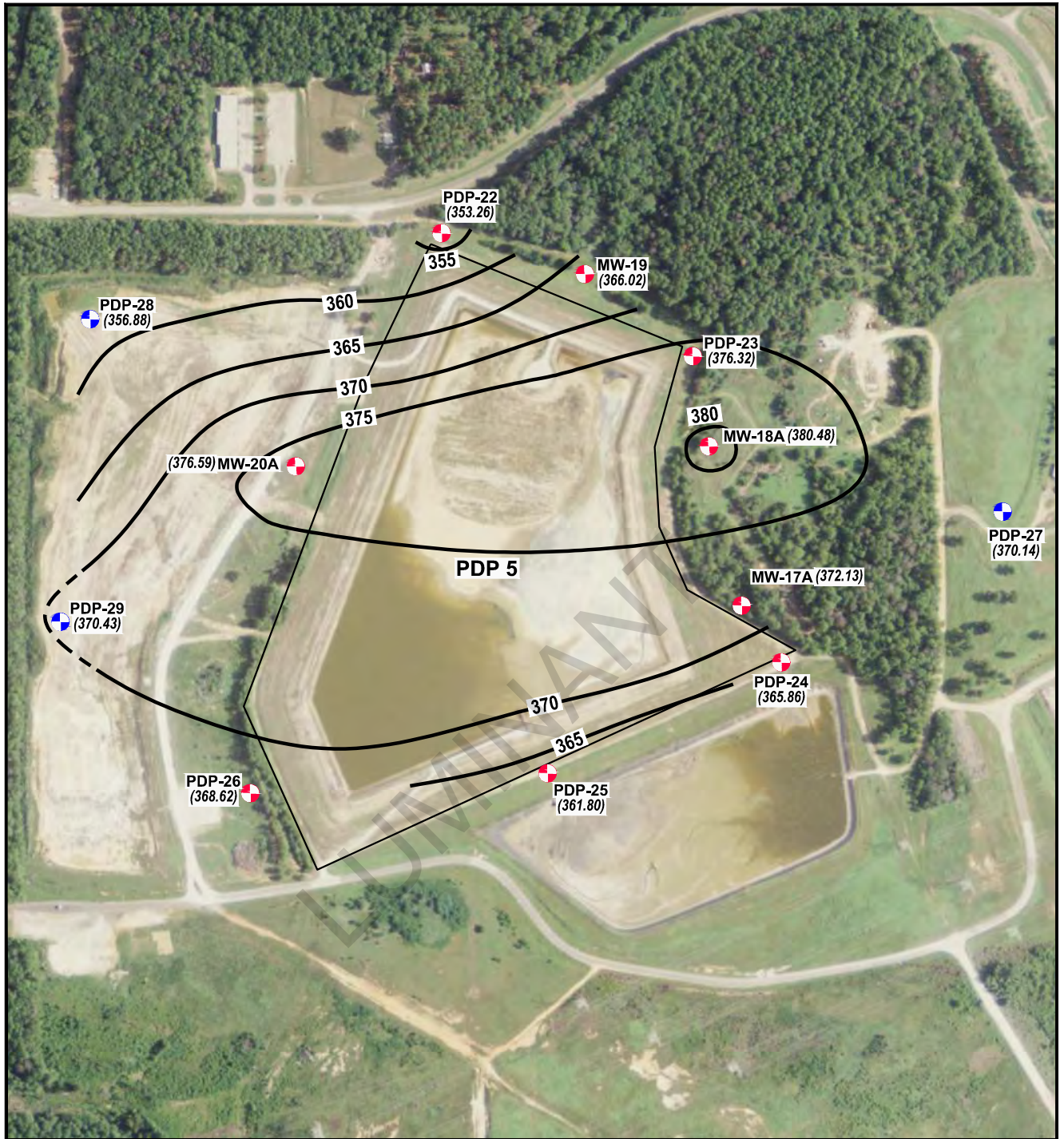
PASTOR, BEHLING & WHEELER, LLC
CONSULTING ENGINEERS AND SCIENTISTS



EXPLANATION

-  CCR Monitoring Well Location
-  Non-CCR Monitoring Well Used to Further Evaluate Groundwater Flow Direction
- (374.34) Groundwater Potentiometric Surface (ft. MSL)
- 360 — Groundwater Potentiometric Surface Contour (C.I. = 5 ft.)



Scale in Feet

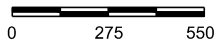

SOURCE:
Imagery from www.tnris.gov, Rusk County, aerial photographs, 2012.

**MARTIN LAKE STEAM ELECTRIC STATION
TATUM, TEXAS**



**PDP 5 - GROUNDWATER
ZONE A POTENTIOMETRIC
SURFACE MAP - JUNE 6, 2016**

PROJECT: 5164B	BY: AJD	REVISIONS
DATE: SEPT., 2017	CHECKED: PJB	

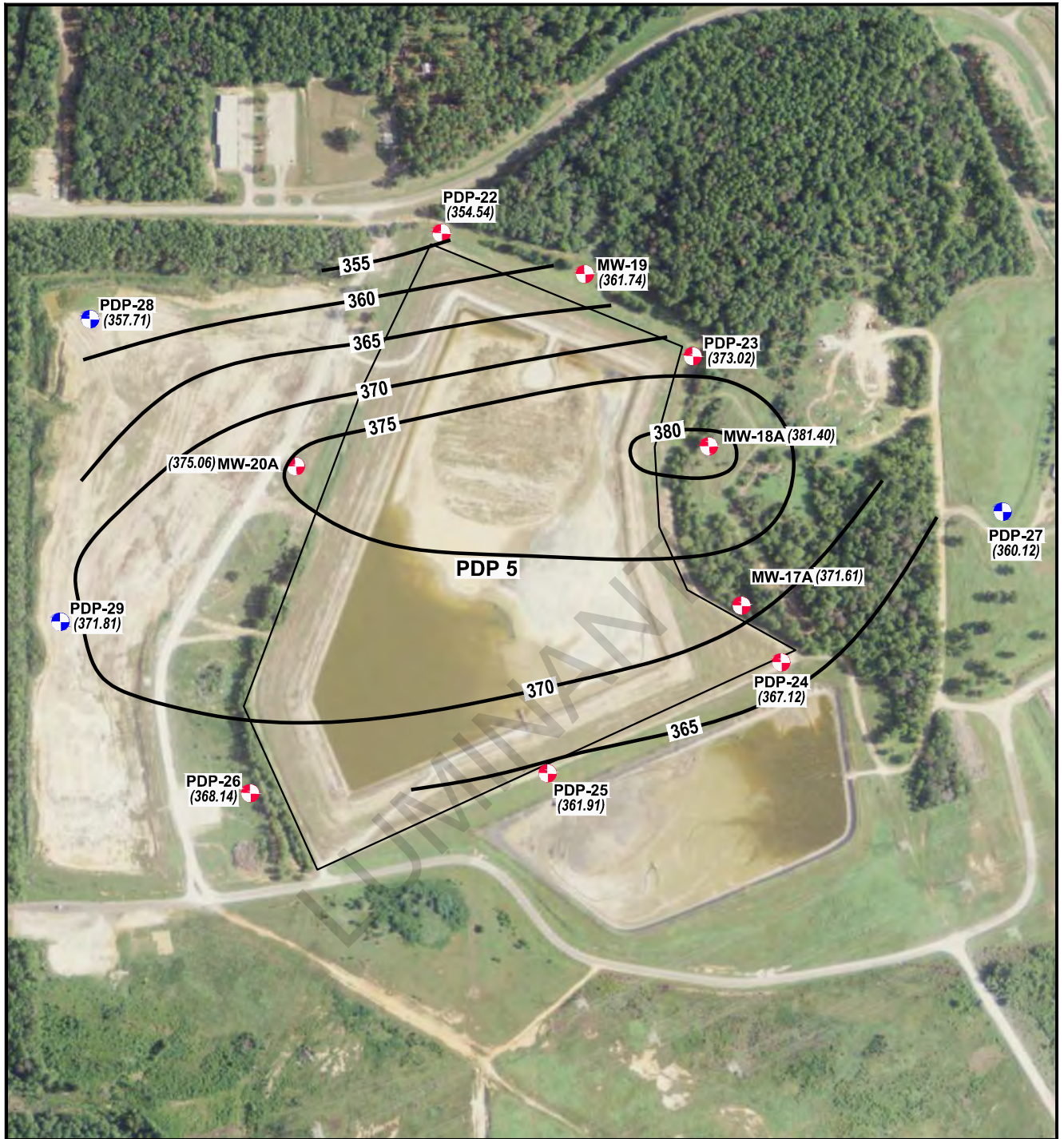
PASTOR, BEHLING & WHEELER, LLC
CONSULTING ENGINEERS AND SCIENTISTS



EXPLANATION

-  CCR Monitoring Well Location
-  Non-CCR Monitoring Well Used to Further Evaluate Groundwater Flow Direction
- (374.34) Groundwater Potentiometric Surface (ft. MSL)
- 360 — Groundwater Potentiometric Surface Contour (C.I. = 5 ft.)

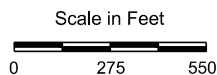

SOURCE:
Imagery from www.tnris.gov, Rusk County, aerial photographs, 2012.

**MARTIN LAKE STEAM ELECTRIC STATION
TATUM, TEXAS**



**PDP 5 - GROUNDWATER
ZONE A POTENTIOMETRIC
SURFACE MAP - AUGUST 9, 2016**

PROJECT: 5164B	BY: AJD	REVISIONS
DATE: SEPT., 2017	CHECKED: PJB	

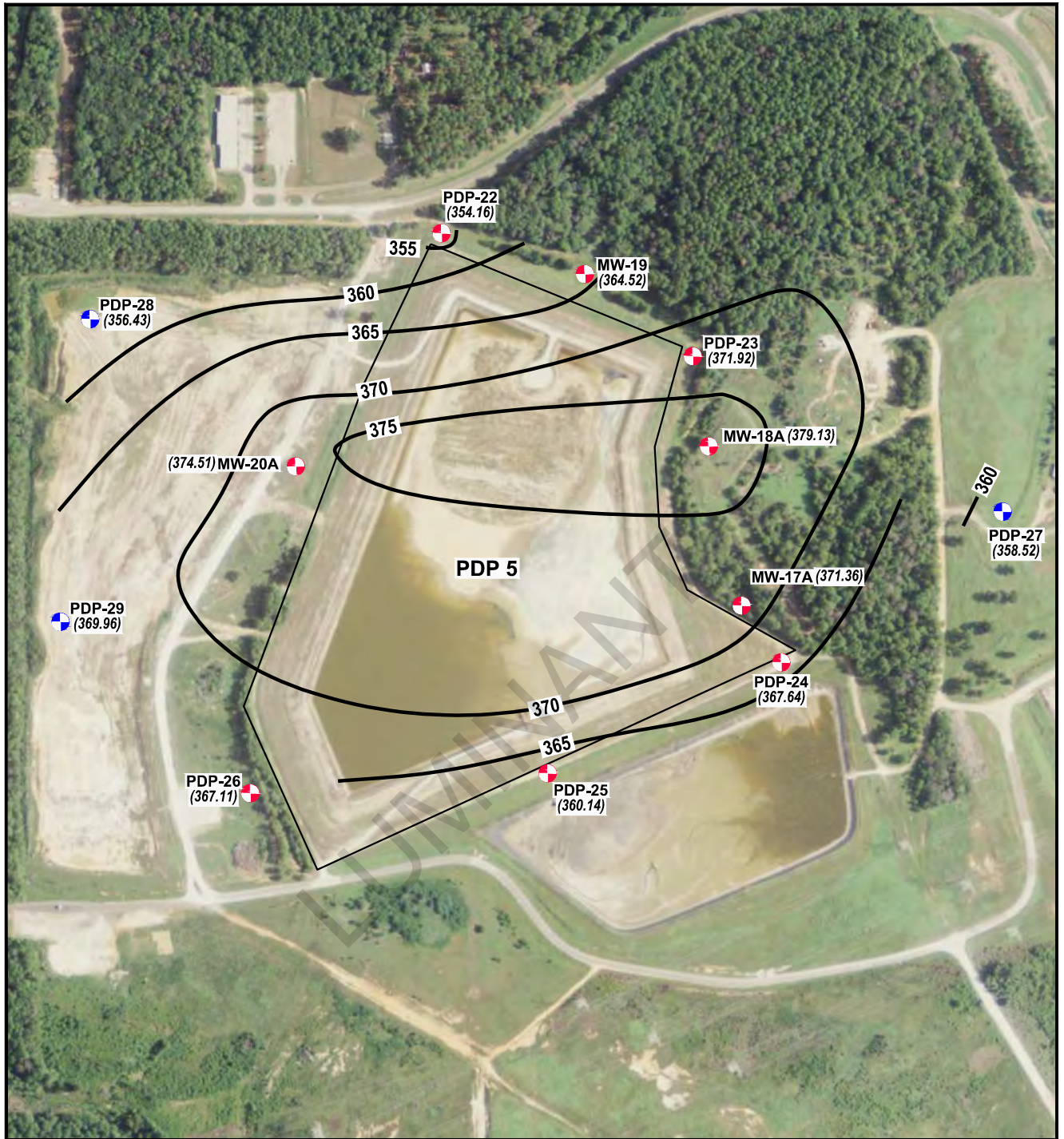
PASTOR, BEHLING & WHEELER, LLC
CONSULTING ENGINEERS AND SCIENTISTS



EXPLANATION

-  CCR Monitoring Well Location
-  Non-CCR Monitoring Well Used to Further Evaluate Groundwater Flow Direction
- (374.34) Groundwater Potentiometric Surface (ft. MSL)
- 360 — Groundwater Potentiometric Surface Contour (C.I. = 5 ft.)

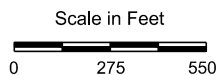

SOURCE:
Imagery from www.tnris.gov, Rusk County, aerial photographs, 2012.

**MARTIN LAKE STEAM ELECTRIC STATION
TATUM, TEXAS**



**PDP 5 - GROUNDWATER
ZONE A POTENTIOMETRIC
SURFACE MAP - OCTOBER 17, 2016**

PROJECT: 5164B	BY: AJD	REVISIONS
DATE: SEPT., 2017	CHECKED: PJB	

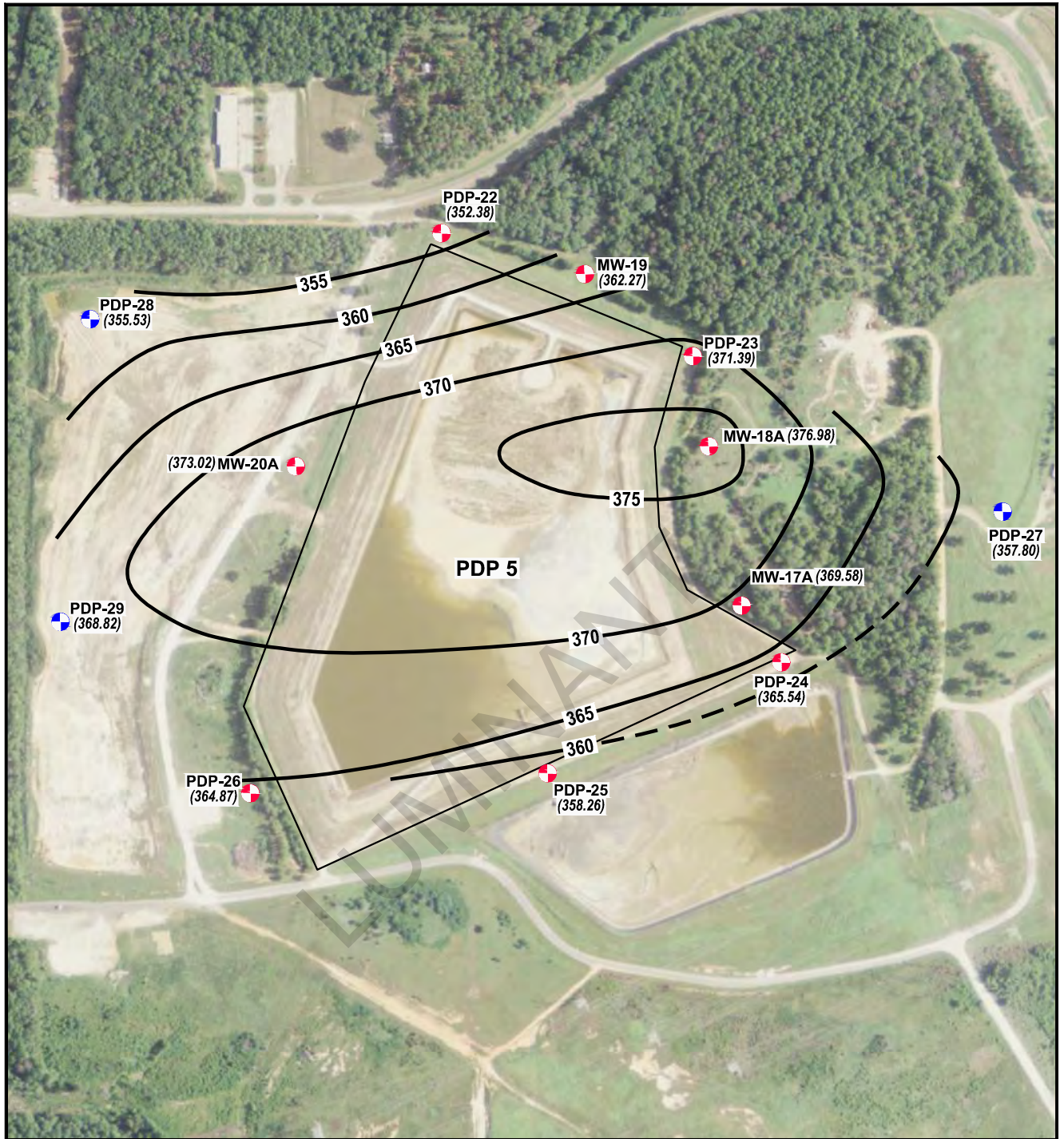
PASTOR, BEHLING & WHEELER, LLC
CONSULTING ENGINEERS AND SCIENTISTS



EXPLANATION

-  CCR Monitoring Well Location
-  Non-CCR Monitoring Well Used to Further Evaluate Groundwater Flow Direction
- (374.34) Groundwater Potentiometric Surface (ft. MSL)
- 360 — Groundwater Potentiometric Surface Contour (C.I. = 5 ft.)

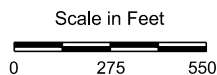

SOURCE:
Imagery from www.tnris.gov, Rusk County, aerial photographs, 2012.

**MARTIN LAKE STEAM ELECTRIC STATION
TATUM, TEXAS**

**PDP 5 - GROUNDWATER
ZONE A POTENTIOMETRIC
SURFACE MAP - DECEMBER 11, 2016**

PROJECT: 5164B	BY: AJD	REVISIONS
DATE: SEPT., 2017	CHECKED: PJB	

PASTOR, BEHLING & WHEELER, LLC
CONSULTING ENGINEERS AND SCIENTISTS

**APPENDIX F4 – TABLES SUMMARIZING CONSTITUENT CONCENTRATIONS AT
EACH MONITORING WELL**

TABLE 1
APPENDIX III GROUNDWATER ANALYTICAL DATA
MARTIN LAKE STEAM ELECTRIC STATION
ASH POND AREA

Sample Location	Date Sampled	B (mg/L)	Ca (mg/L)	Cl (mg/L)	Fl (mg/L)	pH (s.u.)	SO ₄ (mg/L)	TDS (mg/L)
Prediction Limit		0.602	57.2	153	0.4	4.63 7.6	365	1110
Upgradient Wells								
H-26	10/21/15	0.602	24.2	69.2	<0.1	5.82	154	466
	12/14/15	0.0679	9.88	40.3	<0.1	5.91	75.8	280
	02/23/16	0.206	11.7	17.1	0.151 J	6.84	54	219
	04/05/16	0.289	11.8	27.8	0.199 J	5.89	56.8	213
	06/07/16	0.441	11.7	48.6	<0.1	5.98	72.2	278
	08/09/16	0.569	14	70	<0.1	4.63	90.9	354
	10/18/16	0.439	13.6	49.1	0.127 J	6.63	69.7	263
	12/11/16	0.537	11.9	57.6	0.161 J	6.73	68.8	236
	09/21/17	0.579	13.1	67.8	<0.100	6.88	69.6	288
	06/13/18	0.512	17	66.1	<0.100	6.74	67	313
	09/07/18	0.606	11.3	65.1	<0.100	6.85	60.7	265
	05/14/19	0.0507	85.2	61.7	0.140 J	6.83	88.2	453
	09/10/19	0.505	12	72.1	<0.1	6.75	69.4	265
05/13/20	0.644	30.4	71	<0.100		58.4	280	
H-27	10/21/15	0.58	55.3	117	<0.1	6.24	328	800
	12/14/15	0.474	57.2	112	0.156 J	6.32	317	857
	02/23/16	0.523	53.8	113	0.101 J	5.82	344	811
	04/05/16	0.48	52.7	115	0.124 J	6.04	360	819
	06/07/16	0.319	10.6	40.5	<0.1	6.32	55	207
	08/09/16	0.462	54.3	124	<0.1	4.35	365	854
	10/18/16	0.477	56.5	114	0.144 J	6.87	336	868
	12/11/16	0.427	52.8	119	0.161 J	6.78	355	805
	09/21/17	0.48	61.1	122	<0.100	6.87	378	852
	06/13/18	0.404	57	110	0.208 J	6.52	372	850
	09/07/18	0.347	6.96	58.3	0.14 J	6.72	188	716
	05/14/19	0.35	61.8	132	0.159 J	6.78	406	897
	09/10/19	0.368	57.7	117	<0.1	6.77	365	841
05/13/20	0.583	53.1	93	<0.100		274	786	
H-33	10/20/15	0.0462	17.9	60.5	<0.1	5.78	120	415
	12/14/15	0.0596	10.7	59.6	0.136 J	5.73	110	403
	02/23/16	0.0656	11.2	56.1	0.125 J	6.92	111	625
	04/05/16	0.0659	14.9	58.3	0.14 J	6.31	113	589
	06/07/16	0.0571	20.1	67.5	<0.1	6.04	121	515
	08/09/16	0.0431	11.2	64.9	<0.1	5.13	120	442
	10/18/16	0.0539	11.1	59.2	<0.1	6.86	114	398
	12/11/16	0.0594	12.1	63.2	0.132 J	6.85	112	395
	09/21/17	0.0452	13.7	67.9	<0.100	7.02	107	412
	06/13/18	0.114	24	65.5	0.105 J	6.72	93.8	447
	09/07/18	0.112	22.4	66.2	0.135 J	6.73	96.8	489
	05/14/19	0.0592	68.6	80.4	0.166 J	6.81	104	559
	09/10/19	0.0631	44.1	86.1	<0.1	6.75	119	495
05/13/20	0.103	24	84.3	<0.100		113	439	
Downgradient Wells								
H-28	10/21/15	9.25	113	109	<0.1	5.92	1,010	1,830
	12/14/15	1.02	17.3	15.5	<0.1	6.02	113	299
	02/23/16	10.2	123	97.4	<0.1	4.45	1,070	1,910
	04/05/16	10.3	120	94.4	<0.1	5.97	1,080	1,890
	06/07/16	3.66	45.4	62.2	<0.1	6.16	465	817
	08/09/16	9.29	116	98.4	<0.1	3.83	1,080	2,100
	10/18/16	4.96	67.3	91.4	0.165 J	6.82	643	1,460
	12/11/16	3.94	45.7	56.7	0.114 J	6.64	445	766
	09/21/17	6.06	74.1	88.5	<0.100	6.77	702	1,220
	06/13/18	6.97	92.1	96.5	0.126 J	6.59	826	1,490

TABLE 1
APPENDIX III GROUNDWATER ANALYTICAL DATA
MARTIN LAKE STEAM ELECTRIC STATION
ASH POND AREA

Sample Location	Date Sampled	B (mg/L)	Ca (mg/L)	Cl (mg/L)	Fl (mg/L)	pH (s.u.)	SO ₄ (mg/L)	TDS (mg/L)
Prediction Limit		0.602	57.2	153	0.4	4.63 7.6	365	1110
	09/07/18	4.54	60.5	93.4	<0.100	6.84	679	1,330
	05/14/19	8.51	99.7	98.9	<0.100	6.32	935	1,680
	09/10/19	5.69	68.9	95.9	<0.100	6.89	716	1,390
	05/13/20	7.03	88.9	86.7	<0.100		676	1,220
H-29	10/21/15	0.0788	16	65.2	<0.1	5.78	171	441
	12/14/15	0.29	165	8.68	0.56	5.92	178	990
	02/23/16	0.268	59.4	14.6	0.239 J	11.20	156	334
	04/05/16	0.361	80.8	14.2	0.363 J	6.04	181	489
	06/07/16	0.311	29.8	19.3	0.27 J	6.13	166	308
	08/09/16	0.172	64.6	53.1	<0.1	5.97	124	575
	10/18/16	0.953	150	4.33	1.15	6.63	346	607
	12/11/16	1.02	130	4.65	1.4	6.59	365	651
	09/21/17	1.4	147	42	0.304	6.78	170	782
	06/13/18	5.89	81.1	84.1	0.123 J	6.75	713	1,240
	09/07/18	3.21	46.7	78.6	<0.100	6.77	544	1,030
	05/14/19	8.12	95.9	81.8	0.104 J	6.52	780	1,400
	09/10/19	8.05	97.1	90.5	<0.1	6.62	930	1,600
	05/13/20	6.98	84.9	70.7	<0.100		769	1,340
H-31	10/20/15	17.2	194	179	0.889	6.57	1,930	3,270
	12/14/15	20.4	236	147	0.692	6.60	1,740	2,250
	02/23/16	22.3	252	199	0.921	5.33	2,510	4,180
	04/05/16	21.1	250	186	1.36	6.46	2,450	3,920
	06/07/16	22.2	244	241	0.783	6.42	2,720	4,570
	08/09/16	24.1	251	217	0.216 J	4.38	2,730	4,440
	10/18/16	20	236	187	0.298 J	6.82	1,960	3,690
	12/11/16	22.3	246	201	0.892	6.82	2,640	4,170
	09/21/17	23.8	260	227	0.308 J	6.87	2,870	4,570
	06/12/18	16.6	246	205	0.646	6.61	2,390	4,100
	09/07/18	0.838	12.2	17.7	<0.275	6.77	136	457
	05/14/19	20	234	225	0.96	6.42	2,470	4,230
	09/10/18	19.7	234	232	2.1	6.78	2,640	4,220
	05/13/20	22.9	235	223	0.231 J		2,340	4,150
H-32	10/20/15	1.22	42.2	120	0.374 J	6.18	309	797
	12/14/15	1.39	37.4	122	0.619	6.29	325	860
	02/23/16	1.48	45.3	123	0.701	4.82	323	842
	04/05/16	1.65	44.3	125	1.05	6.17	337	831
	06/07/16	1.82	45.6	137	0.858	6.05	350	829
	08/09/16	1.69	45.4	132	0.68	3.64	342	839
	10/18/16	1.72	50.5	121	0.904	6.75	319	888
	12/11/16	2.5 J	44.3	120	1.00	6.83	341	759
	09/21/17	2.07 J	52.8	129	0.519	6.82	337	807
	06/12/18	1.82 J	52.6	126	1.02	6.75	339	793
	09/07/18	0.292 J	10.9	17.8	0.551	6.79	53.8	283
	05/14/19	2.08	45.2	135	1.15	6.02	320	910
	09/10/19	1.87	45.9	127	0.923	6.68	365	810
	05/13/20	2.15	43.3	124	0.641		343	791

Notes:

1. Abbreviations: mg/L - milligrams per liter; TDS - total dissolved solids; s.u. - standard units.
2. J - concentration is below method quantitation limit; result is an estimate.

TABLE 2
APPENDIX IV GROUNDWATER ANALYTICAL DATA
MARTIN LAKE STEAM ELECTRIC STATION
ASH POND AREA

Sample Location	Date Sampled	Sb (mg/L)	As (mg/L)	Ba (mg/L)	Be (mg/L)	Cd (mg/L)	Cr (mg/L)	Co (mg/L)	F (mg/L)	Pb (mg/L)	Li (mg/L)	Hg (mg/L)	Mo (mg/L)	Se (mg/L)	Tl (mg/L)	Ra 226 (pCi/L)	Ra 228 (pCi/L)	Ra 226/228 Comb.^ (pCi/L)	
GWPS:		0.006	0.01	2	0.004	0.005	0.1	0.0564	4	0.015	0.177	0.002	0.1	0.05	0.002	--	--	5	
H-31	10/20/15	<0.0008	0.0168	0.0732	0.0126	0.0032	0.00687	0.434	0.889	<0.0003	0.137	<0.00008	<0.002	0.116	<0.0005	0.943	<1.88	2.82	
	12/14/15	<0.0008	0.00513	0.0388	0.00702	<0.0003	0.00456 J	0.0651	0.692	<0.0003	0.149	<0.00008	<0.002	0.0231	<0.0005	1.61	<1.29	2.90	
	02/23/16	<0.0008	0.00436 J	0.0243	0.0101	<0.0003	<0.002	0.0594	0.921	<0.0003	0.146	<0.00008	<0.002	0.0209	<0.0005	<0.419	<1.64	<2.059	
	04/05/16	<0.0008	0.00514	0.0241	0.00925	<0.0003	0.00435 J	0.0685	1.36	<0.0003	0.146	<0.00008	<0.002	0.0226	<0.0005	<0.334	<0.897	<1.231	
	06/07/16	<0.0008	0.0038 J	0.0242	0.00789	<0.0003	<0.002	0.0406	0.783	<0.0003	0.157	<0.00008	<0.002	0.0307	<0.0005	0.257	<0.555	0.81	
	08/09/16	<0.0008	0.00886	0.0191	0.00734	<0.0003	<0.002	0.286	0.216 J	<0.0003	0.17	<0.00008	<0.002	0.0202	<0.0005	1.31	0.900	2.21	
	10/18/16	<0.0008	0.0035 J	0.0215	0.00167 J	<0.0003	<0.002	0.0304 J	0.298 J	<0.0003	0.165	<0.00008	<0.002	0.0057 J	<0.0005	0.169	1.18	1.35	
	12/11/16	<0.0008	0.0088 J	0.0189	0.0197	<0.0003	0.0039 J	0.23 J	0.892	<0.0003	0.198	<0.00008	<0.002	0.0365	<0.0005	0.195	<0.754	0.95	
	06/12/18	<0.0008	0.00532	0.0194	0.00545	<0.0003	0.003 J	0.236	0.646	<0.0003	0.214	<0.00008	<0.002	0.00475 J	<0.0005	<0.26	<0.597	<0.857	
	09/07/18	NA	<0.002	0.0287	<0.0003	<0.0003	<0.002	0.00353 J	0.275 J	<0.0003	0.0187	NA	NA	0.00424 J	NA	<0.261	<0.567	<0.828	
	05/14/19	<0.0008	0.00675	0.0163	0.00928	<0.0003	0.0032 J	0.389	0.96	<0.0003	0.219	<0.0004	<0.002	0.0261	<0.0005	2.62	<0.789	3.409	
	9/10/2019	NA	0.00845	0.0158	0.0312	<0.0003	0.0031 J	0.41	2.1	<0.0003	0.225	NA	NA	0.0642	NA	0.247	2.92	3.17	
	5/13/2020	<0.0008	0.011	0.0159	0.0331	<0.0003	0.00367 J	0.449	0.231 J	<0.0003	0.249	<0.00008	<0.002	0.0792	<0.0005	0.0808	1.7	1.78	
	H-32	10/20/15	<0.0008	0.0028 J	0.16	0.00266	<0.0003	<0.002	0.163	0.374 J	<0.0003	0.0788	<0.00008	<0.002	0.003 J	<0.0005	1.05	<1.90	2.95
		12/14/15	<0.0008	0.0123	0.0384	0.00313	<0.0003	<0.002	0.155	0.619	<0.0003	0.0733	<0.00008	<0.002	<0.002	<0.0005	0.712	<2.21	2.92
		02/23/16	<0.0008	0.00712	0.0277	0.00452	<0.0003	<0.002	0.188	0.701	0.000326 J	0.0821	<0.00008	<0.002	<0.002	<0.0005	1.12	1.60	2.72
04/05/16		<0.0008	0.00648	0.0237	0.00527	0.00128	<0.002	0.208	1.05	0.00182	0.0818	<0.00008	<0.002	<0.002	<0.0005	<0.364	<1.15	<1.514	
06/07/16		<0.0008	0.0045 J	0.0238	0.00583	0.000997 J	<0.002	0.207	0.858	0.00168	0.087	<0.00008	<0.002	0.003 J	<0.0005	<0.165	0.613	0.778	
08/09/16		<0.0008	0.0034 J	0.0234	0.00548	0.000713 J	<0.002	0.19	0.68	0.00115	0.0774	<0.00008	<0.002	0.0028 J	<0.0005	2.56	<0.446	3.01	
10/18/16		<0.0008	0.0029 J	0.02	0.00567	0.00254	<0.002	0.204	0.904	0.00332	0.0834	<0.00008	<0.002	0.0027 J	<0.0005	<0.139	0.683	0.82	
12/11/16		<0.0008	0.0025 J	0.0205	0.00609	0.00108	<0.002	0.208	1	0.00137	0.0838	<0.00008	<0.002	0.0024 J	<0.0005	<0.163	<0.753	<0.916	
06/12/18		<0.0008	<0.002	0.0175	0.00681	0.000586 J	<0.002	0.215	1.02	0.000701 J	0.0957	<0.00008	<0.002	<0.002	<0.0005	<0.275	0.917	1.192	
09/07/18		NA	<0.002	0.0404	<0.0003	<0.0003	<0.002	0.00347 J	0.551	<0.0003	0.0195	NA	NA	0.0157	NA	0.343	1.25	1.593	
05/14/19		<0.0008	0.002 J	0.0162	0.00713	0.000366 J	<0.002	0.202	1.15	0.000574 J	0.0978	<0.00008	<0.002	0.00675	<0.0005	0.303	<0.546	<0.849	
9/10/2019		NA	<0.002	0.016	0.00678	0.000467 J	<0.002	0.185	0.923	0.00056 J	0.0935	NA	NA	0.0049 J	NA	0.0404	4.74	4.78	
5/13/2020		<0.0008	0.00214 J	0.0166	0.00725	0.000389 J	<0.00200	0.195	0.641	0.000743 J	0.0978	<0.00008	<0.002	0.00401 J	<0.0005	<0.0142	1.15	1.15	

Notes:

1. Abbreviations: mg/L - milligrams per liter; pCi/L - picocuries per liter.
2. ^ - Sum of Ra 226 and Ra 228 concentrations. Non-detect isotope results were assigned a value equal to the minimum detectable concentration.
3. J - concentration is below method quantitation limit; result is an estimate.
4. NA = Not analyzed.

Table 3
Appendix III Groundwater Analytical Data Summary
Matin Lake Steam Electric Station
PDP 5

Sample Location	Date Sampled	B		Ca		Cl		F1		field pH		SO ₄		TDS	
		Prediction Limit	Sample Data	Prediction Limit	Sample Data	Prediction Limit	Sample Data	Prediction Limit	Sample Data	Prediction Limit	Sample Data	Prediction Limit	Sample Data	Prediction Limit	Sample Data
MW-17A	09/22/17		0.402		3.1		8.3		<0.1		6.78		31.2		111
	06/14/18		0.485		6.48		9.16		<0.1		6.87		45.9		129
	09/11/18	0.538	0.523	6.73	5.06	10.4	8.82	0.4	0.179 J	2.5	5.03	51.9	43.1	137	
	05/13/19		0.497		4.88		9.18		<0.1	9.19	6.79		44.7	145	
	11/7/2019		0.52		5.05		8.81		<0.100		6.44		43.9	127	
	5/19/2020		0.521		5.09		8.74		<0.100				46.8	140	
MW-18A	09/22/17		0.0854		1.04		5.27		<0.1		6.94		3.23		45
	06/14/18		0.102		2		6.56		<0.1		6.92		3.48		71
	09/12/18	0.20	0.211	3.1	3.23	10.4	9.06	0.4	<0.1	4.88	5.69	9.1	4.82	150	
	11/07/18		0.128		--		--		--	7.92	--		--	--	
	05/13/19		0.117		1.01		6.17		0.138 J		6.64		3.23	73	
	11/7/2019		0.127		11.5		6.34		<0.100		6.23		3.67	68	
5/19/2020		0.225		1.54		7.09		<0.100				5.97	86		
MW-19	09/22/17		0.0677		2.74		5.36		<0.1		6.94		1.46 J		98
	06/14/18		0.577		133		24.4		0.216 J		6.78		328	758	
	09/11/18	0.782	0.243	237	38	57.7	65.1	0.512	0.228 J	4.6	6.04	672	166	597	
	11/07/18		--		--		5.22		--	8.08	--		--	--	
	05/13/19		0.429		122		26.8		0.229 J		6.72		349	813	
	11/8/2019		0.529		77.8		49.3		0.189 J		6.87		310	844	
5/19/2020		0.0724		1.49		5.84		<0.100				1.02 J	85		
MW-20A	09/22/17		0.0807		17.4		12.6		0.175 J		6.71		74.2		237
	02/2/18 re-sample		--		--		10.7		--		--		--		--
	06/13/18		0.171		24		10.9		0.672		6.72		132		250
	09/11/18	0.213	0.141	25.7	7.16	12.3	11	0.954	0.235 J	3.06	4.70	148	39.1	381	154
	05/13/19		0.239		37.4		10.2		0.731	8.76	6.81		178	328	
	11/8/2019		0.132		9.9		10.2		0.465		6.51		88	205	
5/19/2020		0.22		24		10.4		0.413				133	270		
PDP-22	09/22/17		0.221		92.5		12.3		0.321 J		6.98		178		558
	06/14/18		0.115		7.78		11.8		0.239		6.63		186		491
	09/12/18	0.411	0.164	306	61.1	32.7	10.9	1.07	0.216 J	4.08	5.88	216	143	1,780	
	05/13/19		0.158		98.2		10.1		0.303 J	8.63	6.86		184	615	
	11/12/2019		0.226		34.3		12.6		0.218 J		6.93		215	482	
	5/19/2020		0.0646		54.9		1.06		<0.100				5.21	205	
PDP-23	09/22/17		0.0463		2.34		4.48		0.147 J		6.77		1.47 J		111
	02/2/18 re-sample		--		2.37		--		--		--		--		--
	06/13/18		0.0357		2.29		6.21		<0.1		6.82		1.26 J		98
	09/11/18	0.0678	0.0760	2	1.96	7.52	6.38	0.4	<0.1	3.38	5.32	3.27	1.52 J	143	98
	11/07/18		0.0683		--		--		--	8.45	--		--	--	
	05/13/19		0.0628		1.89		6.98		<0.1		6.68		1.28 J		103
11/12/2019		0.0675		2.14		4.98		<0.100		6.72		1.41 J		93	
5/19/2020		0.0709		2.03		6.86		<0.100				1.19 J		104	
PDP-24	09/22/17		3.01		25.8		17.5		0.898		6.95		231		440
	06/14/18		2.71		23.9		21.1		0.629		6.82		284		481
	09/11/18	4.92	4.08	45.9	41.6	22.6	19.4	1.03	0.832	1.33	4.20	533	460	760	
	05/13/19		3.23		23		21		0.871	9.97	6.95		300	894	537
	11/12/2019		3		21.9		20.6		0.751		6.87		295	520	
	11/12/2019		2.97		22.2		20.5		0.744		6.87		300	504	
5/19/2020		3.17		21.4		21		0.61				286	512		
PDP-25	09/22/17		0.133		36.8		130		0.157 J		6.81		89.1		481
	06/14/18		0.119		40.4		111		<0.1		6.78		73.4		439
	09/11/18	0.136	0.167	41.3	36.2	197	135	0.4	0.115 J	4.66	5.87	118	90.3	705	469
	11/07/18		0.142		--		--		--	7.93	--		--	--	
	05/13/19		0.144		44.4		108		0.121 J		6.84		69	469	
	11/12/2019		0.184		38.6		117		<0.100		6.82		71.4	454	
5/19/2020		0.202		53.7		105		<0.100				62.2	442		
PDP-26	09/22/17		0.0343		2.32		5.24		0.157 J		6.84		5.88		107
	06/14/18		0.0225 J		2.93		4.8		<0.1		6.89		4.27		100
	09/12/18	0.111	0.0371	4.74	2.37	14.6	4.88	0.577	<0.1	5.35	6.07	64.6	2.66 J	438	107
	05/13/19		0.0528		1.9		4.59		0.217 J	7.57	6.86		2.7 J	106	
	11/12/2019		0.0622		2.25		4.64		0.122 J		6.77		2.1 J	102	
	5/19/2020		0.0538		2.09		4.52		<0.100				2.1 J	108	

Notes:
1. All concentrations in mg/L, pH in standard units.
2. J - concentration is below sample quantitation limit; result is an estimate.
3. Highlighted sample results exceed the prediction limit.

**APPENDIX F5 – SITE HYDROGEOLOGY AND STRATIGRAPHIC CROSS-
SECTIONS OF THE SITE**

CONCEPTUAL SITE MODEL AND DESCRIPTION OF SITE HYDROGEOLOGY (ASH POND AREA)

The Martin Lake Steam Electric Station (Martin Lake) conceptual site model (CSM) and Description of Site Hydrogeology for the Ash Pond Area (APA), which includes the East Bottom Ash Pond (EAP), West Bottom Ash Pond (WAP), and New Scrubber Pond (NSP) located near Tatum, Texas are described in the following sections.

REGIONAL SETTING

The APA is located in the Martin Creek area on the west flank of the Sabine Uplift within the Sabine River Valley (Golder, 2016). Formations in the Martin Creek area mainly include continental and marine sedimentary deposits of Eocene-aged Wilcox Group (Barnes, 1965; Golder, 2016), which are overlain by sands of the Carrizo Formation at higher elevations (not present at the APA) (Golder, 2019). The Wilcox formation is approximately 650 to 700 feet thick in the Martin Creek area, and includes sandy clays, silty sands, clays, and variable amounts of lignite (Golder, 2016). The Wilcox Group was described as mostly unconsolidated to moderately consolidated clay and silt with variable degrees of interbedded sand and lignite in the area of the Site (Golder, 2019), and derived from a depositional environment associated with fluvial-deltaic processes, which may include inter-channel crevasses splays, overbank deposits, and localized channel fills (Golder, 2019). In the Martin Creek area, the Wilcox Group is underlain by the approximately 900-foot thick silty clay and clay deposits of the Paleocene Midway Group, which overlies approximately 7000 feet of Cretaceous rock (Golder, 2016).

Potable water supply wells are completed in Wilcox Group sands of the Martin Creek area, including two Martin Lake locations upgradient of the APA (screened at depths of at least 300 feet below ground surface) (Golder, 2019). In addition, to these Martin Lake potable water supply wells, other groundwater wells completed in the Wilcox Group sands include well used for domestic, oil and gas, or stock watering purposes (Golder, 2019).

Groundwater occurring within the upper 100 feet below ground surface in the Martin Creek area is typically under unconfined or semi-confined conditions, where the potentiometric surface of these shallow flow systems typically mirror that of the topographic surface (Golder, 2019). Groundwater flow is generally from the potentiometric highs that mimic the topographic highs (coincident with groundwater recharge areas, groundwater divides and surface water divides) toward potentiometric lows and valleys (coincident with groundwater discharge zones) (Golder, 2019).

SITE GEOLOGY

The APA is located in the outcrop area of the Wilcox Group described above (PBW, 2017). Surficial soils in the vicinity of the APA include the following (described in order from shallow to deep) based on soil borings (Golder, 2019):

- Upper Zone - low to medium plasticity lean clay to clayey sand, occurring at thicknesses ranging from approximately 30 to 40 feet.
- Intermediate Zone (Uppermost Aquifer) - poorly-graded fine sand and silty sand, occurring at thicknesses ranging from approximately 5 to 20 feet.
- Lower Confining Unit - laterally-continuous silty to sandy clay.

Cross-sections showing the subsurface materials encountered at the APA are included as an attachment to this demonstration. Drilling logs used to develop the cross-sections are also included as an attachment to this demonstration.

SITE HYDROGEOLOGY

Seven monitoring wells are included in the CCR groundwater monitoring system, which includes three upgradient monitoring wells (H-26, H-27, and H-33) and four downgradient monitoring wells (H-28, H-29, H-31, and H-32) (PBW, 2017) (see Monitoring Well Location Map, and Well Construction Diagrams and Drilling Logs attached to this demonstration). All wells included in the CCR monitoring system are screened in the intermediate zone (i.e., uppermost aquifer) at the APA (PBW, 2017).

Hydraulic Conductivity

Hydraulic conductivity results from field testing (i.e., slug tests) in the upper zone (clayey sand) and intermediate zone (sand and silty sand) ranged from 3.5×10^{-6} to 3.8×10^{-4} centimeters per second (cm/s) and 1.2×10^{-4} to 7.5×10^{-3} cm/s, respectively as reported by PBW (2017).

Groundwater Elevations, Flow Direction and Velocity

Groundwater elevations adjacent to the APA for the eight CCR background monitoring events from October 2015 through December 2016 ranged from approximately 302.30 feet above mean sea level (amsl) to 310.04 feet amsl, corresponding to groundwater depths from 9.24 to 26.94 feet below ground surface (PBW, 2017). In general, groundwater elevations were highest in the west, with inferred groundwater flow direction to the east toward Martin Lake during the eight background monitoring events (PBW, 2017). These groundwater elevations and flow directions are consistent with the groundwater potentiometric map for May 2019 included as an attachment to this demonstration (Golder, 2019). Golder (2019) estimated the lateral groundwater flow velocity in the intermediate zone (i.e., uppermost aquifer) to be 27 feet per year.





REFERENCES

- Barnes, Virgil E., 1965. Geologic Atlas of Texas, Tyler Sheet, Texas Bureau of Economic Geology.
- Golder Associates Inc. (Golder). 2016. Safety Factor Assessment Report, Martin Lake Steam Electric Station.
- Golder Associates Inc. (Golder). 2019. CCR Assessment of Corrective Measures, Martin Lake Steam Electric Station – Ash Pond Area, Rusk County, Texas.
- Pastor, Behling & Wheeler (PBW). 2017. Coal Combustion Residual Rule Groundwater Monitoring System Certification, Martin Lake Steam Electric Station, Ash Pond Area, Rusk County, Texas. October 16.



Last Edited By: adamond Date: 2019-08-28 Time: 12:16:40 PM | Printed By: adamond Date: 2019-08-28 Time: 12:33:09 PM
 Path: \\s01\h01\ad\Projects - Round Rock\19121403 - Luminant\Martin Lake Ash Pond Area | File Name: FIG 2 - Detailed Site Plan (Ash Pond Area).dwg

LEGEND

-  DOWNGRADIENT CCR MONITORING WELL
-  UPGRADIENT CCR MONITORING WELL
-  LAKE WATER/GROUNDWATER MIXING ZONE SAMPLE
-  MNA SOIL SAMPLE
-  CROSS SECTION LOCATION

CLIENT
LUMINANT

PROJECT
MARTIN LAKE STEAM ELECTRIC STATION
TATUM, TEXAS

TITLE
DETAILED SITE PLAN - ASH POND AREA

CONSULTANT	YYYY-MM-DD	2019-08-28
	DESIGNED	AJD
	PREPARED	AJD
	REVIEWED	WFV
	APPROVED	WFV

REFERENCE(S)
BASE MAP TAKEN FROM GOOGLE EARTH, IMAGERY DATED 4/6/17.

PROJECT NO. 19121403 REV. 0 FIGURE 2

IF THIS MEASUREMENT DOES NOT MATCH WHAT IS SHOWN, THE SHEET SIZE HAS BEEN MODIFIED FROM ANS/A

Path: \\nasdaq\cdeaf\projects - flume\19121403 - Luminant\Martin Lake Ash Pond Area | File Name: FIG 3-A - Cross Section.dwg | Last Edited By: adamson | Date: 2019-08-28 | Time: 2:52:58 PM

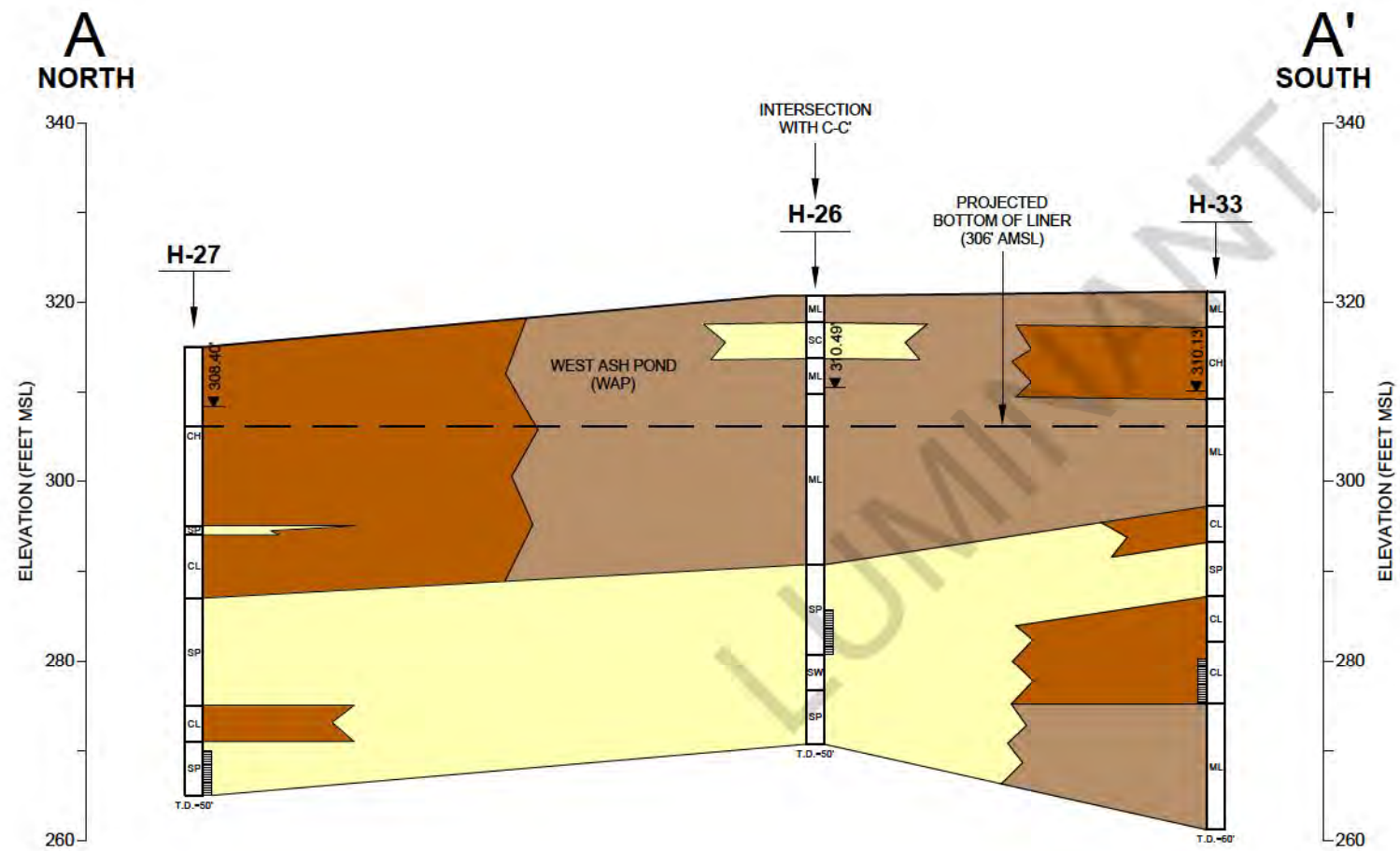

LEGEND

	FILL
	SAND
	CLAY
	SILT

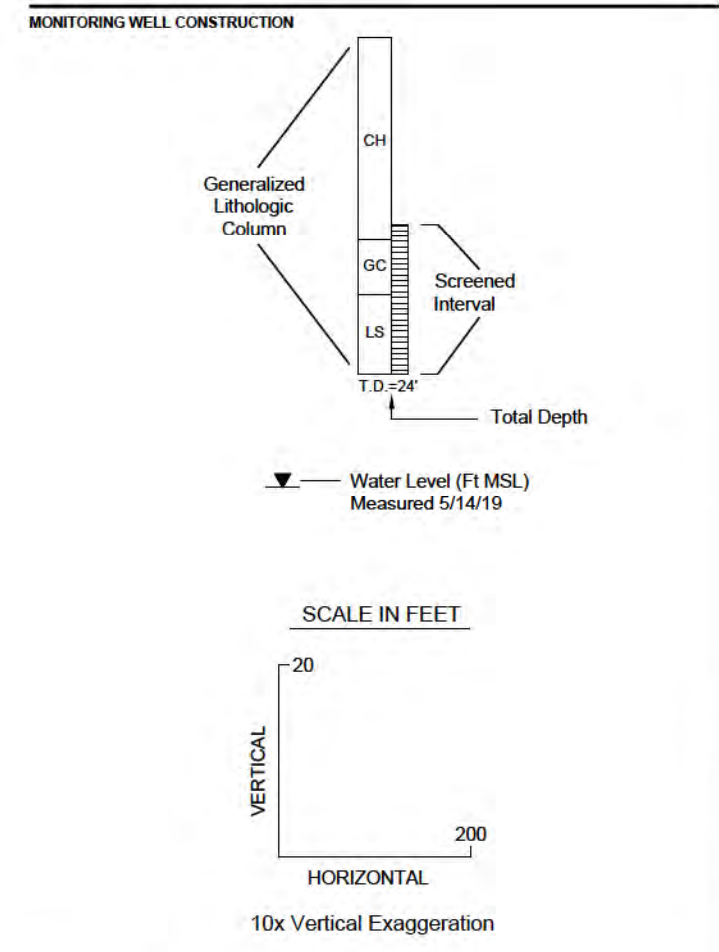

CLIENT		LUMINANT
PROJECT		MARTIN LAKE STEAM ELECTRIC STATION TATUM, TEXAS
TITLE		ASH POND AREA - GEOLOGIC CROSS SECTION A-A' WEST SIDE OF WEST ASH POND THROUGH PROCESS WATER POND
CONSULTANT	YYYY-MM-DD	2019-08-28
	DESIGNED	AJD
	PREPARED	AJD
	REVIEWED	WFV
	APPROVED	WFV
PROJECT NO.	REV.	FIGURE
19121403	0	3

IF THIS MEASUREMENT DOES NOT MATCH WHAT IS SHOWN, THE SHEET SIZE HAS BEEN MODIFIED FROM ANSIB

Path: \\msr\share\geotech\Projects - River\19121403 - Luminant\Martin Lake Ash Pond Area | File Name: FIG 3.5 - Geologic Cross Section.dwg | Last Edited By: Administrator | Date: 2019-08-28 | Time: 2:33:28 PM

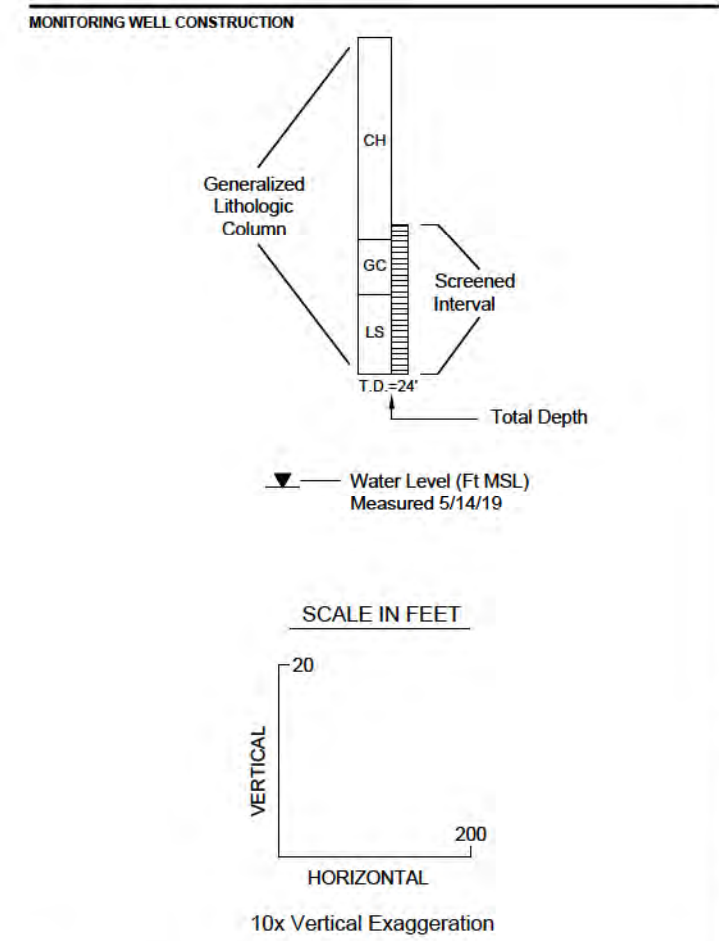
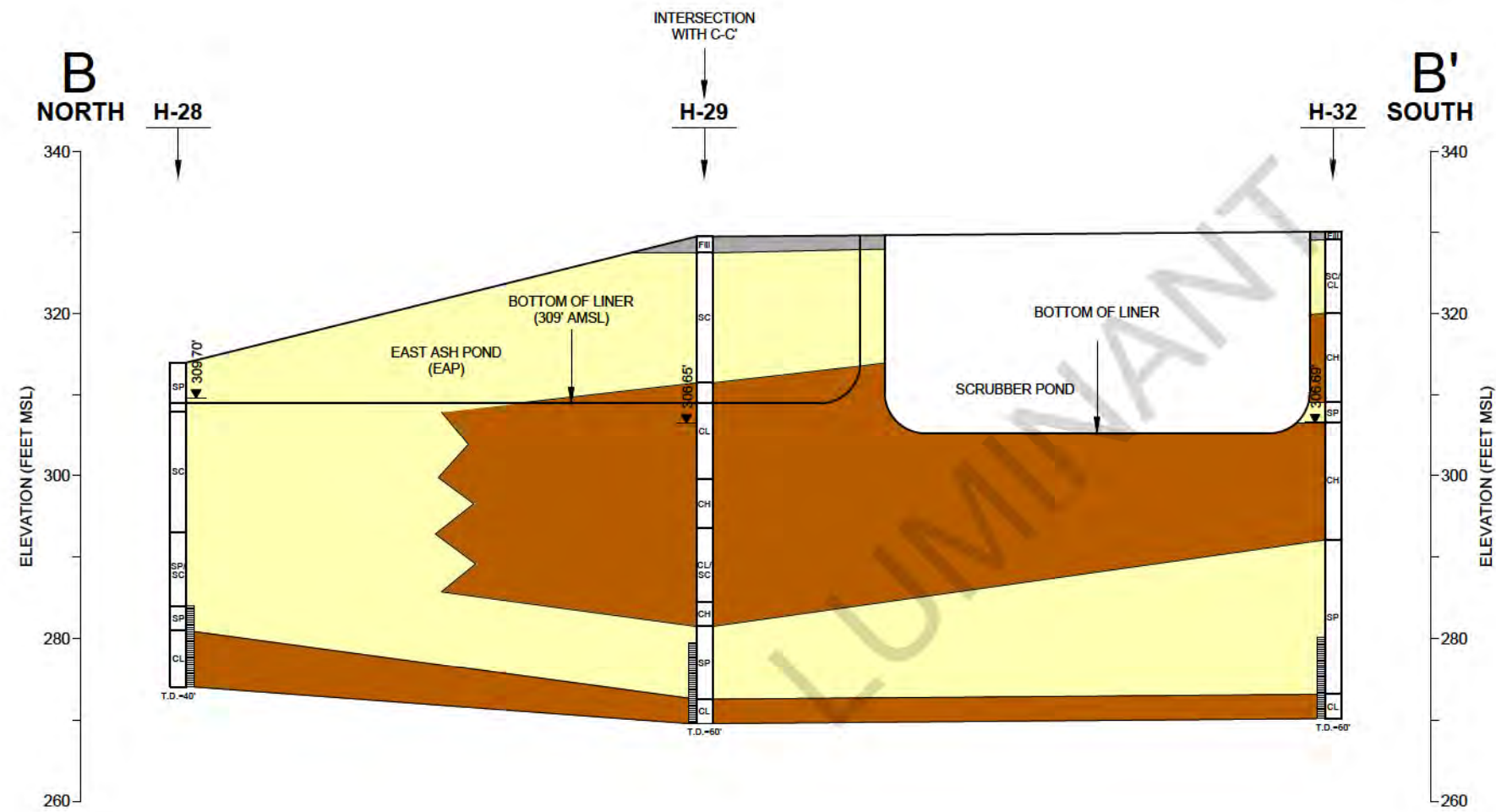

CLIENT
LUMINANT

PROJECT
MARTIN LAKE STEAM ELECTRIC STATION
TATUM, TEXAS

TITLE
**ASH POND AREA - GEOLOGIC CROSS SECTION B-B'
EAST SIDE OF ASH POND THROUGH SCRUBBER POND**

CONSULTANT	YYYY-MM-DD	2019-08-28
DESIGNED	AJD	
PREPARED	AJD	
REVIEWED	WFV	
APPROVED	WFV	

IF THIS MEASUREMENT DOES NOT MATCH WHAT IS SHOWN, THE SHEET SIZE HAS BEEN MODIFIED FROM ANSI B

Path: \\nasdaq\cdeaf\projects - RiverDoc\19121403 - LuminantMartin Lake Ash Pond Area | File Name: FIG 3.5 - Cross Section.dwg | Last Edited By: adamson | Date: 2019-08-28 | Time: 2:44:02 PM

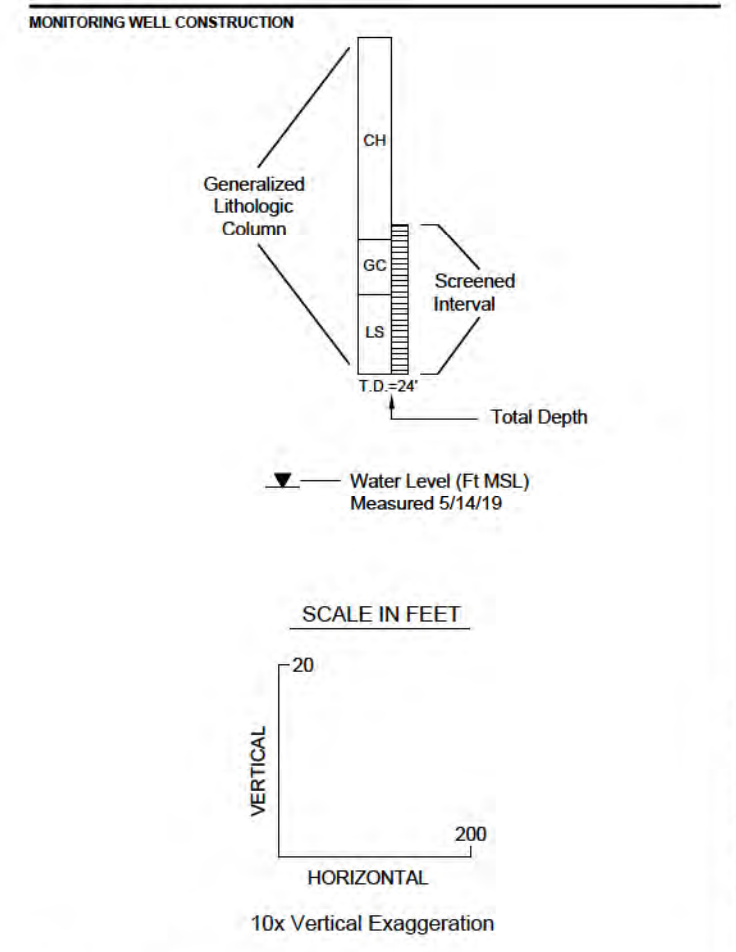
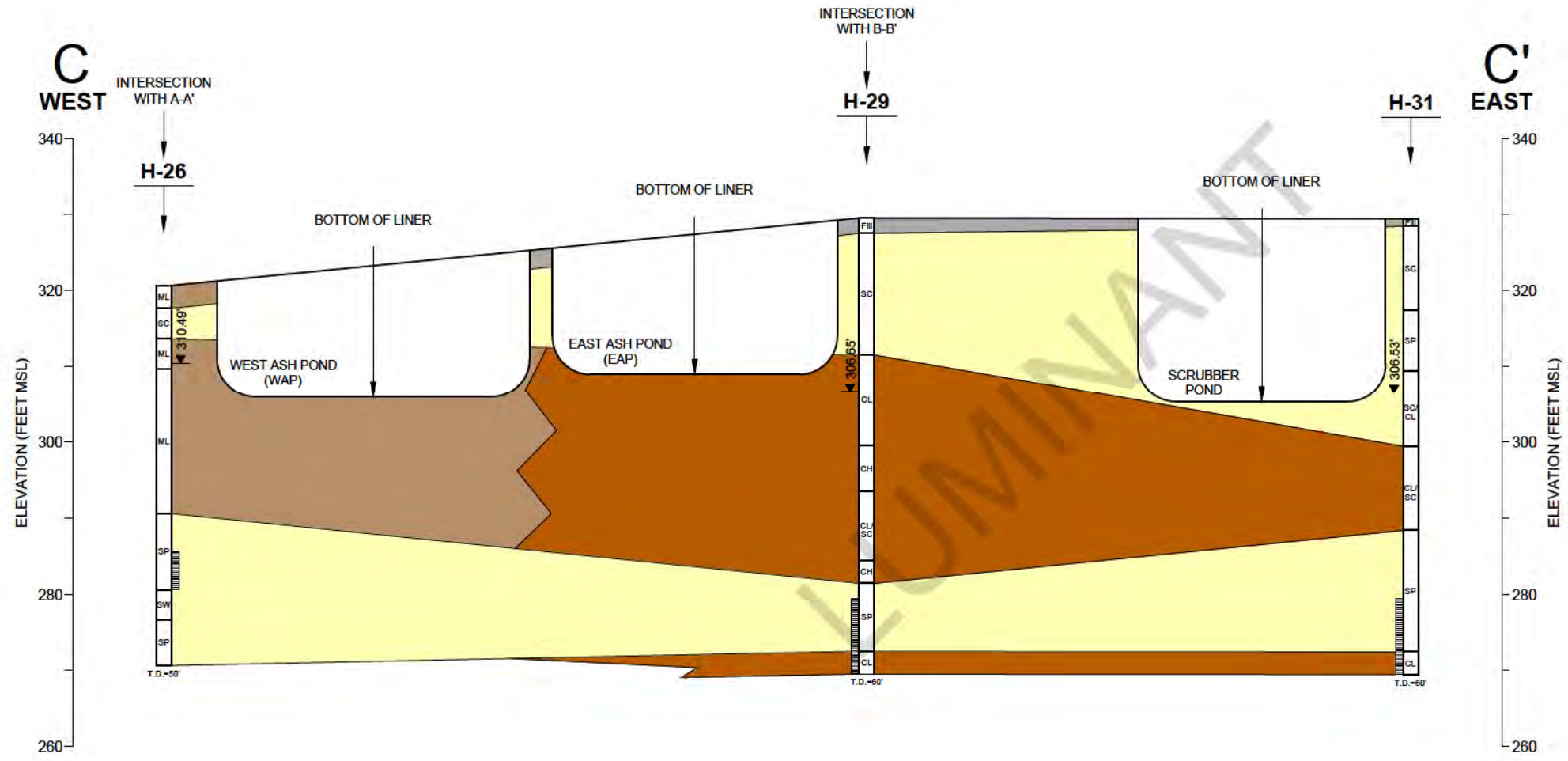

CLIENT
LUMINANT

PROJECT
MARTIN LAKE STEAM ELECTRIC STATION
TATUM, TEXAS

TITLE
**ASH POND AREA - GEOLOGIC CROSS SECTION C-C'
THROUGH WEST ASH POND AND EAST ASH POND**

CONSULTANT	YYYY-MM-DD	2019-08-28
	DESIGNED	AJD
	PREPARED	AJD
	REVIEWED	WFV
	APPROVED	WFV

PROJECT NO. 19121403

REV. 0

FIGURE 5

IF THIS MEASUREMENT DOES NOT MATCH WHAT IS SHOWN, THE SHEET SIZE HAS BEEN MODIFIED FROM ANSI B

CONCEPTUAL SITE MODEL AND DESCRIPTION OF SITE HYDROGEOLOGY (PERMANENT DISPOSAL POND 5)

The Martin Lake Steam Electric Station (Martin Lake) conceptual site model (CSM) and Description of Site Hydrogeology for the Permanent Disposal Pond-5 (PDP5), located near Tatum, Texas are described in the following sections.

REGIONAL SETTING

The PDP5 is located in the Martin Creek area on the west flank of the Sabine Uplift within the Sabine River Valley (Golder, 2016). Formations in the Martin Creek area mainly include continental and marine sedimentary deposits of Eocene-aged Wilcox Group (Barnes, 1965; Golder, 2016), which are overlain by sands of the Carrizo Formation at higher elevations (Golder, 2019). The Wilcox formation is approximately 650 to 700 feet thick in the Martin Creek area, and includes sandy clays, silty sands, clays, and variable amounts of lignite (Golder, 2016). The Wilcox Group was described as mostly unconsolidated to moderately consolidated clay and silt with variable degrees of interbedded sand and lignite in the area of the Site (Golder, 2019), and derived from a depositional environment associated with fluvial-deltaic processes, which may include inter-channel crevasses splays, overbank deposits, and localized channel fills (Golder, 2019). In the Martin Creek area, the Wilcox Group is underlain by the approximately 900-foot thick silty clay and clay deposits of the Paleocene Midway Group, which overlies approximately 7000 feet of Cretaceous rock (Golder, 2016).

Potable water supply wells are completed in Wilcox Group sands of the Martin Creek area, including two Martin Lake locations (screened at depths of at least 300 feet below ground surface) (Golder, 2019). In addition, to these Martin Lake potable water supply wells, other groundwater wells completed in the Wilcox Group sands include well used for domestic, oil and gas, or stock watering purposes (Golder, 2019).

Groundwater occurring within the upper 100 feet below ground surface in the Martin Creek area is typically under unconfined or semi-confined conditions, where the potentiometric surface of these shallow flow systems typically mirror that of the topographic surface (Golder, 2019). Groundwater flow is generally from the potentiometric highs that mimic the topographic highs (coincident with groundwater recharge areas, groundwater divides and surface water divides) toward potentiometric lows and valleys (coincident with groundwater discharge zones) (Golder, 2019).

SITE GEOLOGY

The PDP5 is located in the outcrop area of the Wilcox Group described above (PBW, 2017). Surficial soils in the vicinity of PDP5 include the following (described in order from shallow to deep) based on soil borings (PBW, 2017):

- Upper Sand Unit – an upper sand unit is observed on hilltops and other topographically high areas.
- Intermediate Continuous Clay Unit – a continuous clay unit that contains discontinuous packages of relatively thick layers of interbedded sand.
- Lower Silt and Sand Unit (Uppermost Aquifer) – a silt and sand unit that contains discontinuous packages of relatively thick layers of clay.

A cross-section showing the subsurface materials encountered in the vicinity of PDP5 is included as an attachment to this demonstration. Drilling logs used to develop the cross-section are also included as an attachment to this demonstration.

SITE HYDROGEOLOGY

Nine monitoring wells (MW-17A, MW-18A, MW-19, MW-20A, PDP-22, PDP-23, PDP-24, PDP-25, and PDP-26), positioned radially around PDP5, are included in the CCR groundwater monitoring system. Groundwater flow directions around PDP5 indicate there are no upgradient areas in the vicinity of the CCR unit and all nine CCR groundwater monitoring wells are downgradient of PDP5 (PBW, 2017) (see Monitoring Well Location Map, and Well Construction Diagrams and Drilling Logs attached to this demonstration). All wells included in the CCR monitoring system are screened in the lower silt and sand unit (i.e., uppermost aquifer) at the PDP5 (PBW, 2017).

Hydraulic Conductivity

Hydraulic conductivity results from field testing (i.e., slug tests) at monitoring wells PDP-22, PDP-25, and PDP-26 in the lower sand and silt unit (uppermost aquifer) ranged from approximately 2.48×10^{-5} to 1.37×10^{-4} centimeters per second (cm/s), with a geometric mean of approximately 4.40×10^{-5} cm/s (PBW, 2017).

Groundwater Elevations and Flow Direction

Groundwater elevations adjacent to the PDP5 for the eight CCR background monitoring events from October 2015 through December 2016 ranged from approximately 352.38 feet above mean sea level (amsl) to 381.40 feet amsl, corresponding to groundwater depths from 5.14 to 37.46 feet below ground surface (PBW, 2017). In general, mounding was observed within PDP5 with an inferred radial groundwater flow outward from PDP5 (PBW, 2017). These groundwater elevations and flow directions are consistent with the groundwater potentiometric map for December 2016 included as an attachment to this demonstration (PBW, 2017).

REFERENCES

- Barnes, Virgil E., 1965. Geologic Atlas of Texas, Tyler Sheet, Texas Bureau of Economic Geology.
- Golder Associates Inc. (Golder). 2016. Safety Factor Assessment Report, Martin Lake Steam Electric Station.
- Golder Associates Inc. (Golder). 2019. CCR Assessment of Corrective Measures, Martin Lake Steam Electric Station – Ash Pond Area, Rusk County, Texas.
- Pastor, Behling & Wheeler (PBW). 2017. Coal Combustion Residual Rule Groundwater Monitoring System Certification, Martin Lake Steam Electric Station, Permanent Disposal Pond 5, Rusk County, Texas. October 16.



EXPLANATION

- MW-12A ● A Zone Monitoring Well
- MW-12B ● B Zone Monitoring Well



Scale in Feet

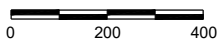

**LUMINANT - MARTIN LAKE SES
PDP 1, 2 AND 3 CLOSURE REPORT**

Figure 3

**PDP 1, 2 AND 3
POST CLOSURE SITE PLAN**

PROJECT: 5058	BY: AJD	REVISIONS
DATE: NOV., 2014	CHECKED: PJB	

PASTOR, BEHLING & WHEELER, LLC
CONSULTING ENGINEERS AND SCIENTISTS

SOURCE:
Base map from <http://www.tnris.state.tx.us>, Tatum SW DOQQ, Texas, 2010.

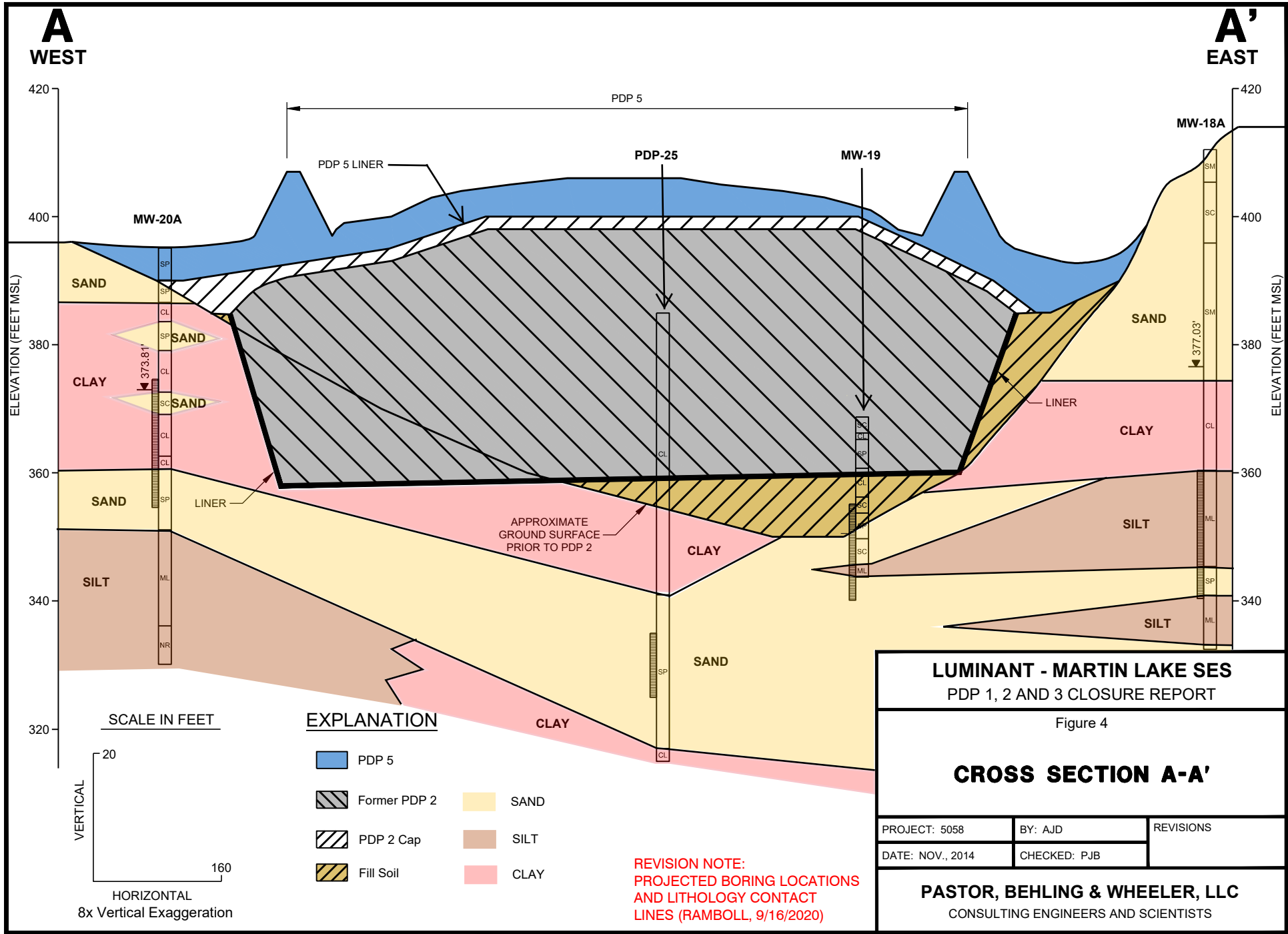

APPENDIX F6 – CORRECTIVE MEASURES ASSESSMENT (ASH POND AREA)



REPORT

CCR ASSESSMENT OF CORRECTIVE MEASURES

*Martin Lake Steam Electric Station - Ash Pond Area
Rusk County, Texas*

Submitted to:

Luminant Generation Company LLC

Submitted by:

Golder Associates Inc.

2201 Double Creek Dr, Suite 4004, Round Rock, Texas, USA 78664

+1 512 671-3434

19121403

September 2019

LUMINANT

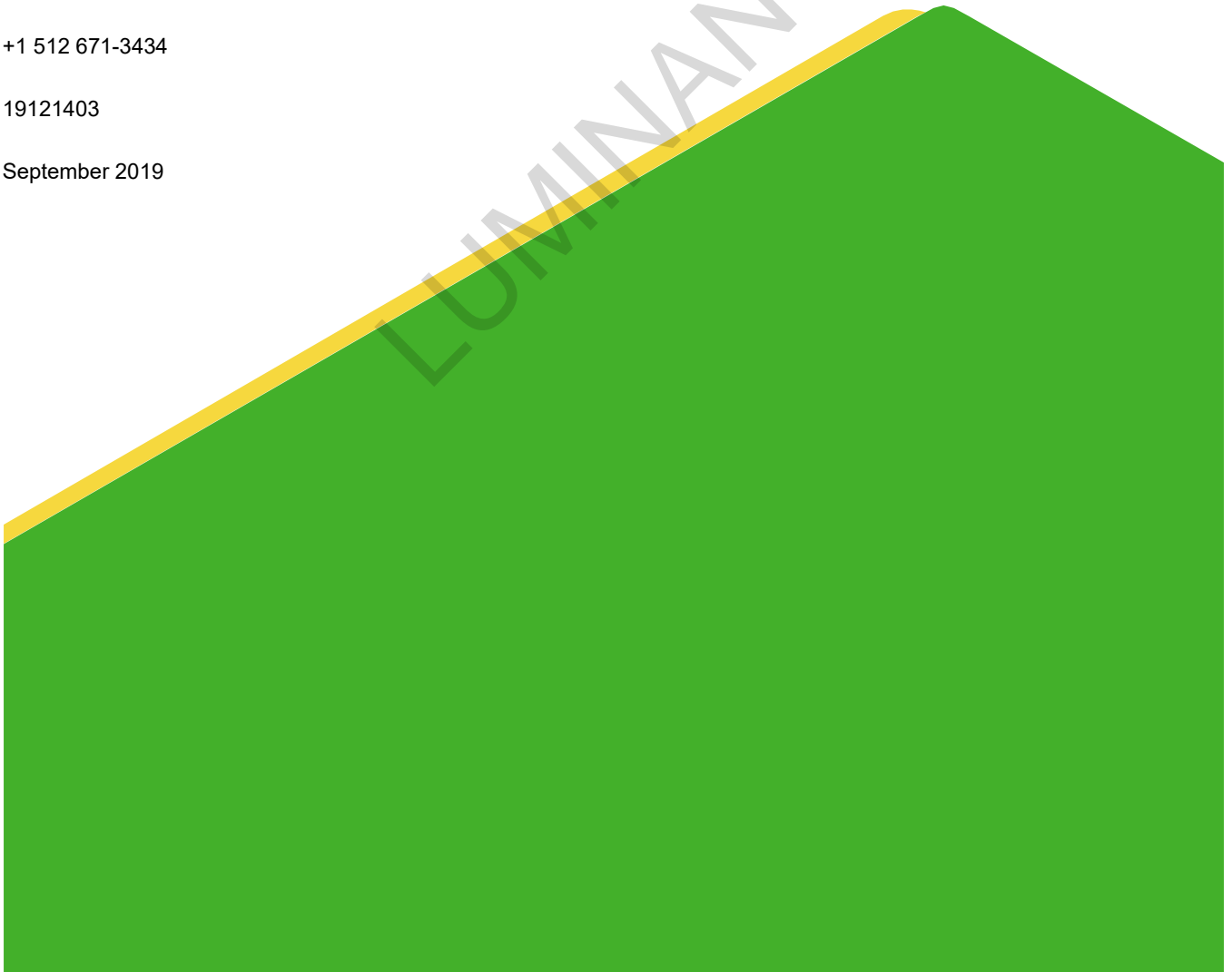

Table of Contents

1.0	INTRODUCTION	1
2.0	REGIONAL AND SITE SETTING	2
2.1	Regional Geology	2
2.2	Regional Hydrogeology	2
2.3	Site Hydrogeology and CCR Monitoring Well Network	2
3.0	NATURE AND EXTENT EVALUATION	4
3.1	Groundwater Monitoring Summary	4
3.2	Assessment Monitoring SSL Evaluation	4
3.3	Field Investigation	6
3.3.1	General	6
3.3.2	Soil Sample Collection	7
3.3.3	Groundwater and Surface Water Sampling	7
3.4	Evaluation of Groundwater Water	8
3.4.1	Geochemical Modeling Approach	8
3.4.2	Summary of Groundwater and Surface Water Data	8
3.5	Evaluation of Soil	10
3.5.1	Mineralogical Composition	10
3.5.2	Chemical Composition and Sequential Extraction	10
3.6	Summary of Site Characterization	11
4.0	ASSESSMENT OF CORRECTIVE MEASURES	13
4.1	Corrective Measures Objectives and Evaluation Criteria	13
4.2	Potential Source Control Response Technologies	13
4.3	Potential Groundwater Response Technologies	14
4.3.1	Monitored Natural Attenuation	14
4.3.2	Groundwater Extraction and Treatment	15
4.3.3	Vertical Hydraulic Barrier	16

4.3.4	Permeable Reactive Barrier	17
4.3.5	In-situ Chemical Treatment.....	18
4.3.6	Phytoremediation	18
4.3.7	Screening of Potential Groundwater Response Technologies	19
4.4	Potential Corrective Measures Alternatives	19
4.5	Remedy Selection	19
5.0	REFERENCES	20

TABLES

Table 1	Appendix IV Groundwater Analytical Data Summary
Table 2	Screening of Potential Groundwater Response Technologies
Table 3	Evaluation of Corrective Measures Alternatives

FIGURES

Figure 1	Site Location Map
Figure 2	Detailed Site Plan
Figure 3	Geologic Cross Section A-A'
Figure 4	Geologic Cross Section B-B'
Figure 5	Geologic Cross Section C-C'
Figure 6	Potentiometric Surface Map – May 14, 2019
Figure 7	Extent of Appendix IV Constituents Detected at SSLs Above GWPSs
Figure 8a	Major Groundwater Chemistry
Figure 8b	Select Relative Ion Abundance in Groundwater at Monitoring Wells
Figure 9a	Historical Trends of Beryllium in Groundwater at Monitoring Wells
Figure 9b	Historical Trends of Cobalt in Groundwater at Monitoring Wells
Figure 9c	Historical Trends of Lithium in Groundwater at Monitoring Wells
Figure 10a	Pourbaix Diagram – Speciation of Beryllium in Groundwater
Figure 10b	Pourbaix Diagram – Speciation of Cobalt in Groundwater

APPENDICES

Appendix A	Boring Logs
Appendix B	Laboratory Analytical Reports
Appendix C	Groundwater Sampling Records

1.0 INTRODUCTION

Golder Associates Inc. (Golder) has prepared this assessment of corrective measures (ACM) report on behalf of Luminant Generation Company LLC (Luminant) for the West Ash Pond (WAP), East Ash Pond (EAP), and New Scrubber Pond (NSP) (collectively referred to as the “Ash Pond Area”) located at the Martin Lake Steam Electric Station (MLSES) in Rusk County, Texas (hereafter, the “Site”). The ACM was prepared in accordance with §257.96 of the Coal Combustion Residual (CCR) Rule and was required due to the presence of concentrations of selected Appendix IV constituents at statistically significant levels (SSLs) above the groundwater protection standards (GWPS) established for the constituents at the Site. This ACM Report will be placed in the MLSES operating record in accordance with §257.105(h)(10).

This report also incorporates the results of a site investigation conducted at the Site in May and June 2019. The objectives of the site investigation were:

- delineate the nature and extent of the selected Appendix IV constituents to their respective GWPS;
- update the statistical evaluations of the Appendix IV constituents to include data collected during 2019 to confirm that SSL exceedances continue to occur at the Site;
- collect data to evaluate potential future alternate source demonstrations (ASDs) for the Appendix IV constituents; and
- assess the potential for monitored natural attenuation (MNA) to be successful at the Site for the Appendix IV constituents.

The MLSES is located approximately 5 miles southeast of Tatum, Rusk County, Texas (Figure 1). The MLSES is expected to remain in operation for the foreseeable future, depending on future power demands.

The Ash Pond Area is located immediately east of the MLSES power units (Figure 2). The WAP is constructed with a composite liner consisting of an 18-inch thick compacted clay liner, overlain by two 60-mil HDPE geomembrane liners with a geonet drainage layer between the geomembranes. The EAP is constructed with a composite liner consisting of an 18-inch thick compacted clay liner, overlain by a geotextile, overlain by two 60-mil HDPE geomembrane liners with a geonet drainage layer between the geomembranes. A 4-inch thick concrete revetment mat is installed on top of the upper geomembrane liner in both the WAP and EAP. The WAP and EAP are considered unlined surface impoundments under §257.71(a)(1)(ii) of the CCR Rule (BM 2016).

The NSP is constructed with liner system consisting of two 60-mil HDPE geomembrane liners with a geonet drainage layer between the geomembranes, overlain by a 4-inch thick concrete revetment mat. The NSP is considered an unlined surface impoundment under §257.71(a)(1)(ii) of the CCR Rule (BM 2016).

2.0 REGIONAL AND SITE SETTING

2.1 Regional Geology

MLSES is located in the outcrop area of the Eocene-aged Wilcox Group (Barnes, 1965). The Wilcox Group in the vicinity of the Site consists mostly of unconsolidated to moderately consolidated clay and silt, with various amounts of interbedded sand and lignite. The depositional environment is associated with fluvial-deltaic processes such as inter-channel crevasse splays, overbank deposits, and localized channel fills. The Wilcox Group is overlain by sands of the Carrizo Formation, which is present only at higher elevations in the area. The Carrizo Formation is not present at the Site.

2.2 Regional Hydrogeology

Groundwater wells completed in the Wilcox Group sands in the area are typically used for domestic, oil and gas supply, or stock watering purposes. Some potable water supply wells in the region are also completed in the Wilcox Group, including two wells at the MLSES that are both located upgradient of the Ash Pond Area and are screened at depths of 300 feet bgs or greater. Groundwater within the upper 100 feet below ground surface (bgs) in the region typically flows under unconfined to semi-confined conditions. The direction and rate of groundwater movement in the Wilcox Group are affected by a number of physical features, including topography, surface drainage, and geology. The natural groundwater potentiometric surface in these shallow flow systems is generally a subdued replica of topography. In general, groundwater flow occurs from high potentiometric areas (recharge zones) toward valleys (discharge zones). Groundwater divides generally coincide with surface drainage divides.

2.3 Site Hydrogeology and CCR Monitoring Well Network

The CCR groundwater monitoring well network at the Ash Pond Area was established in 2015 using newly installed monitoring wells H-26, H-27, H-28, H-29, H-31, H-32, AND H-33 (Figure 2). Based on soil borings completed at the Site, the geology near the CCR units generally consists of an upper zone composed of an approximately 30- to 40-foot thick low- to medium-plasticity, lean clay to clayey sand unit. The upper zone is underlain by an intermediate zone composed of poorly-graded fine sand and silty sand unit that is generally about 5 to 20 feet thick. The intermediate zone is underlain by a laterally-continuous, silty to sandy confining clay unit. The uppermost aquifer occurs in the intermediate sand and silty sand unit at the Site (PBW 2017a). The CCR monitoring wells are completed in the intermediate zone. Geologic cross sections of the Ash Pond Area are presented on Figures 3, 4, and 5.

Groundwater elevations are generally highest near the western side of the Ash Pond Area with an inferred groundwater flow direction to the east toward Martin Lake. A groundwater potentiometric map constructed using groundwater elevation data collected in May 2019 from the CCR monitoring network is presented on Figure 6. Based on the inferred groundwater flow direction, the location of each CCR monitoring well relative to the Ash Pond Area is as follows:

Upgradient/Background Wells	Downgradient Wells
H-27	H-28
H-26	H-29
H-33	H-31
	H-32

Rising- and falling-head aquifer tests (i.e., slug tests) were conducted at the Site as part of a 2011 assessment for the Texas Commission on Environmental Quality (TCEQ) Texas Risk Reduction Program (TRRP) (PBW 2011). Based on the test results, the intermediate zone had an estimated hydraulic conductivity of 1.0E-03 cm/sec and an estimated lateral groundwater flow velocity of 27 feet per year.

Golder performed a survey of water supply wells located in the vicinity of the Ash Pond Area in May 2019 as part of a Texas Commission on Environmental Quality (TCEQ) Texas Risk Reduction Program (TRRP) assessment of the Site. A Drinking Water Survey Report (Golder, 2019) documenting the water well survey activities and findings was approved by the TCEQ in a letter dated August 15, 2019. No imminent threats to water wells or potentially affected drinking water wells were identified.

LUMINANT

3.0 NATURE AND EXTENT EVALUATION

3.1 Groundwater Monitoring Summary

Background monitoring of groundwater in the vicinity of the Ash Pond Area began in October 2015 and was completed in December 2016. Samples collected during this period were analyzed for Appendix III and Appendix IV constituents to establish background concentrations pursuant to §257.94(b).

A detection monitoring program in accordance §257.94 was initiated in September 2017. The evaluation of those data was completed in 2018 using procedures described in the Statistical Analysis Plan (PBW 2017b) to identify statistically significant increases (SSIs) of Appendix III parameters above background concentrations. Based on the identification of SSIs for one or more Appendix III parameters, an assessment monitoring program was established pursuant to §257.94(e)(1).

The initial assessment monitoring event was performed in June 2018 and a subsequent semi-annual assessment monitoring event was conducted in September 2018 in accordance with §257.95(a) and §257.95(d). Using the Appendix IV data collected during the assessment monitoring period through September 2018, SSLs above GWPSs were initially identified in downgradient wells in January 2019 for beryllium (H-28, and H-29), cobalt (H-28 and H-29), and lithium (H-28); therefore, an ACM was initiated on April 8, 2019 pursuant to §257.95(g). A justification letter for a 60-day extension due to site-specific circumstances that delayed work on the ACM was certified on July 3, 2019 in accordance with §257.96(a). Based on the extension, the deadline for completing the ACM is September 5, 2019.

3.2 Assessment Monitoring SSL Evaluation

An additional assessment monitoring event was performed in May 2019. Groundwater sampling analytical results for all Appendix IV parameters from 2015 through 2019 are presented in Table 1. An updated statistical analysis of the Appendix IV results from downgradient CCR monitoring wells was conducted including the May 2019 data to evaluate if constituent concentrations detected in the samples remained at SSLs relative to the GWPSs. The updated statistical analysis was performed in accordance with the Statistical Analysis Plan for CCR Groundwater Monitoring (PBW 2017b) and the USEPA Statistical Analysis of Groundwater Monitoring Data at RCRA Facilities- Unified Guidance (USEPA 2009). Confidence intervals were calculated for any Appendix IV parameter that historically has had more than one occurrence in excess of the GWPS in any well within the monitoring network. Plots of the confidence intervals for each of those Appendix IV parameters are presented below (SSLs are highlighted in red around the bars):

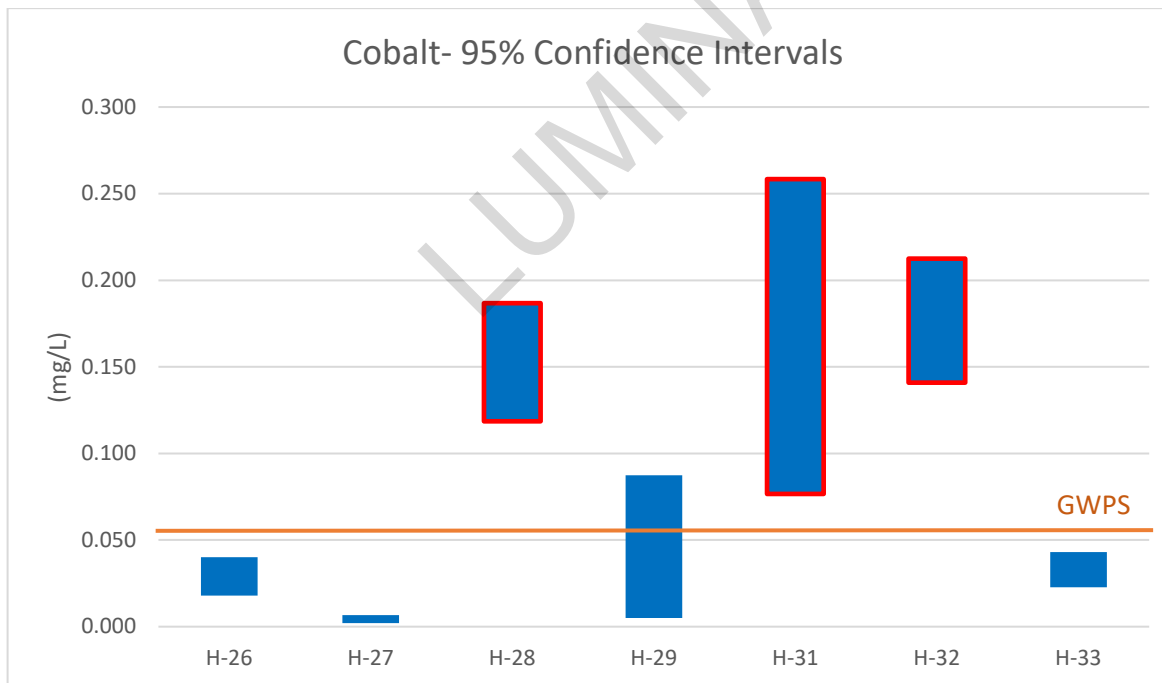
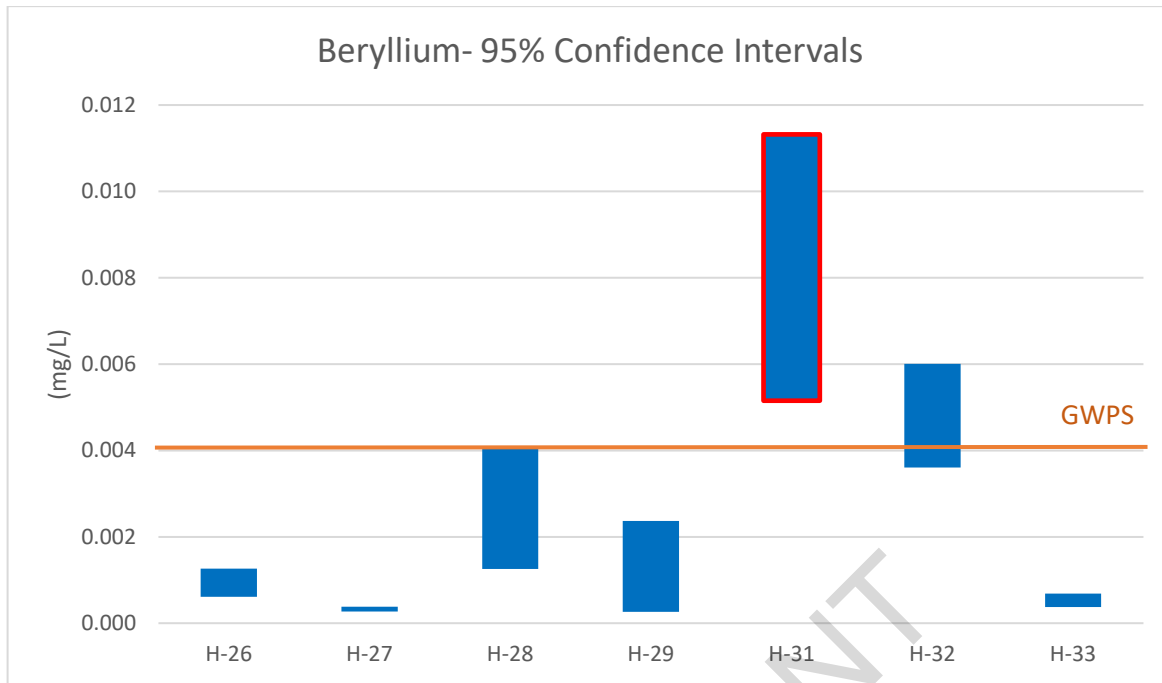

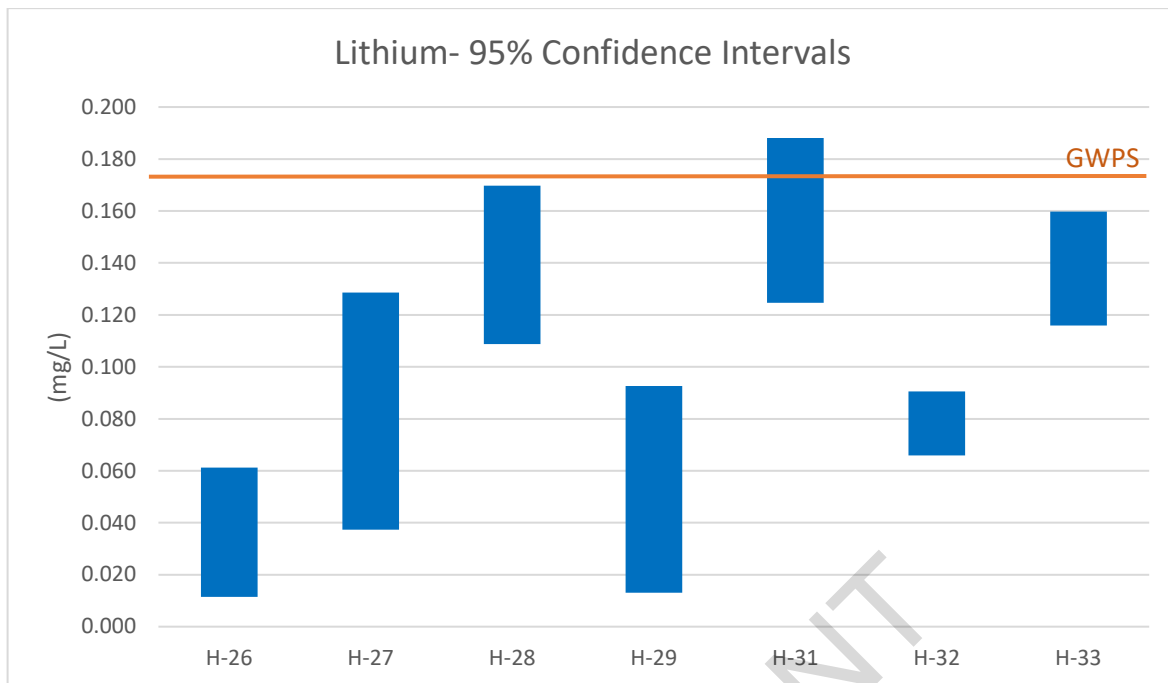

The previous statistical analysis using data collected during the assessment monitoring period through September 2018 indicated SSLs for beryllium (H-28 and H-29), cobalt (H-28 and H-29), and lithium (H-28) as identified in the February 2019 SSL notification; however, the updated statistical analysis only identified beryllium (H-31) and cobalt (H-28, H-31, and H-32) as having SSLs above GWPSs. The monitoring wells will continue to be monitored to confirm that lithium concentrations remain below SSLs in the future in accordance with the CCR Rule. For the purposes of this ACM evaluation, concentrations are conservatively assumed to be present at SSLs above their respective GWPSs for the following constituents in the wells indicated based on the initial and updated statistical evaluations:

- Beryllium (H-28, H-29, and H-31);
- Cobalt (H-28, H-29, H-31, and H-32); and
- Lithium (H-28).

Figure 7 shows the extent of Appendix IV constituents detected at SSLs above GWPSs based on the initial and updated statistical analysis.

3.3 Field Investigation

3.3.1 General

Field investigation activities conducted as part of the ACM included collection of soil samples for a mineralogical assessment and chemical analysis, a lake sample from Martin Lake, groundwater-level measurements, and groundwater sampling and analysis. Figure 2 presents the locations of soil borings and monitoring wells installed and sampled as part of the field investigation.

3.3.2 Soil Sample Collection

Soil borings were completed in June 2019 at soil boring locations AP-2019-1, AP-2019-2, and AP-2019-3. Soil samples were collected within the target GWBU in each of the soil borings. Soil samples were submitted under chain-of-custody for laboratory analysis of the following parameters:

- **Mineralogical composition:** The purpose of the mineralogical analysis was to identify and quantify the crystalline mineral phases in each sample. This information is required for geochemical modeling as the release or attenuation of constituents of interest is influenced by the mineral phase(s) present in the aquifer (Hem 1985). The mineralogical testing laboratory (SGS Minerals Services) performed the analysis using quantitative (Rietveld) X-ray diffraction (XRD) (ME-LR-MIN-MET-MN-DO5) and a Bruker AXS D8 Advance Diffractometer.
- **Total metals:** Analysis of total metals was conducted to quantify the chemical composition of soil materials. The total mass of metals, in combination with the results of sequential extraction testing, can be used to determine the provenance of metals and verify sequential extraction results.
- **Sequential extraction (SEP):** This test consists of a seven-step metals extraction from solids as per Tessier et al. (1979) to identify the provenance of constituents of interest (i.e. the operationally-defined fraction that contains the metal) and determine their potential environmental mobility. For instance, metals bound in the carbonate fraction, or that are exchangeable, are much more likely to become mobile due to changes in groundwater conditions than metals bound within a sulfide or silicate fraction. The total concentration of a metal measured from all seven steps can be compared to the concentration determined from the total metal analysis for compositional accountability.

3.3.3 Groundwater and Surface Water Sampling

Groundwater samples were collected from the CCR monitoring network and one surface water sample was collected from Martin Lake downgradient of the Ash Pond Area in May 2019. Laboratory analytical reports are provided in Appendix B and sampling records, which include field-measured parameters, are presented in Appendix C.

Chemical/geochemical analysis of groundwater samples included field parameters and radionuclides, nutrients, and major cations and anions. The rationale and methods used are as follows:

- **Field Parameters:** Parameters measured in the field included pH, dissolved oxygen, oxidation reduction potential (ORP), conductivity, and temperature. These parameters were used to evaluate general geochemical conditions in the groundwater and support geochemical modeling.
- **Metals and Regulated COIs:** Analysis of Appendix III and IV metals and uranium to better understand the geochemical composition of groundwater. Metals analysis allows for the delineation of a potential plume, evaluation of mineral saturation indices, and evaluation of background contributions from natural sources or anthropogenic sources.
- **Major Cations, Anions, and Nutrients:** Geochemical modeling of mineral solubility, metals attenuation and background contributions requires analysis of major cations and anions because they affect and participate in sorption and mineral dissolution or precipitation reactions.

3.4 Evaluation of Groundwater Water

3.4.1 Geochemical Modeling Approach

Geochemical modeling was conducted to evaluate general groundwater quality, determine the potential for precipitation of sorbent media, evaluate the potential for mineral precipitation or adsorption in the aquifer, and determine the speciation of metals of interest. The geochemical computer code developed by the United States Geological Survey (USGS), PHREEQC, was used for these simulations (Parkhurst and Appelo 2013). PHREEQC version 3.4 is a general-purpose geochemical modeling code used to simulate reactions in water and between water and solid mineral phases (e.g., rocks and sediments). Reactions include aqueous equilibria, mineral dissolution and precipitation, ion exchange, surface complexation, solid solutions, gas-water equilibrium, and kinetic biogeochemical reactions. The widely-accepted thermodynamic database Minteq.v4, 2017 edition, was used as a basis for the thermodynamic constants required for modeling.

The Geochemist's Workbench Version 12 (Bethke 2015) was used to generate graphical representations of geochemical modeling outputs in the form of predominance, or Pourbaix diagrams (also known as Eh-pH diagrams) for the species of interest (i.e. beryllium and cobalt) and trilinear plots (also known as Piper plots) displaying the relative abundance of major ions. The Minteq.v4 database was used as the basis for the Pourbaix diagrams.

3.4.2 Summary of Groundwater and Surface Water Data

Groundwater quality data from background wells H-26, H-27, and H-33; downgradient monitoring wells H-28, H-29, H-31, and H-32; and the surface water sample collected from Martin Lake were used for this evaluation. The water quality monitoring data are presented in Appendices B and C and can be summarized as follows:

General Chemistry Parameters

- **pH:** The pH of groundwater samples collected from CCR monitoring well network ranged from 6.01 to 6.83 in May 2019. Historically, the pH in the CCR monitoring well network has ranged from 5.8 to 7.0. Isolated values as low as 3.64 and as high as 11.20 have been recorded in some wells; however, these conditions do not persist but pH returns to circumneutral values by the next sampling round. The pH of Martin Lake was 6.79 in May 2019.
- **ORP (Redox):** Field-measured redox values, corrected to Eh (+200mV), ranged from +113 to +174 mV in the groundwater samples in the CCR monitoring well network.
- **Total Dissolved Solids (TDS):** Groundwater TDS concentrations were variable in May 2019 in the CCR monitoring well network. The lowest TDS concentration (453 mg/L) occurred in groundwater at CCR monitoring well H-26 (upgradient) and the highest TDS value (4,230 mg/L) was observed at CCR monitoring well H-31 (downgradient). The TDS concentration measured in Martin Lake water was 119 mg/L.
- **Major ion chemistry:** A Piper plot was generated for groundwater and Martin Lake samples to facilitate the identification of water types and source contributions (Figure 8a). Two distinct groupings of wells are apparent based on their relative major ion proportions. Upgradient wells H-26 and H-33 show close similarity with the water sample from Martin Lake, indicating potential influences of Martin Lake on the groundwater in these locations. Groundwater composition in upgradient well H-27, in contrast, is more closely related to that of the downgradient wells. Based on the molar ratios of calcium, sodium, and sulfate (Figure 8b), all groundwater samples and the Martin Lake water sample generally plot as one group.

- **Iron:** Oxidized iron (ferric iron - Fe^{+3}) concentrations were variable, ranging from non-detect (<0.05 mg/L) to 8.81 mg/L in May 2019 (Appendix B). Reduced iron (ferrous iron - Fe^{+2}) concentrations were non-detect (<0.05 mg/L) in the groundwater at all CCR monitoring wells except H-31 and H-32. The highest concentration of ferrous iron in groundwater was 49.5 mg/L observed in monitoring well H-31, over 40 times higher than any other monitoring well. This value corresponded to the highest measured beryllium, cobalt, and lithium concentrations in groundwater at the Ash Pond area. Ferric iron in water from Martin Lake was measured at 0.365 mg/L while ferrous iron was non-detect (<0.05 mg/L).
- **Nutrients:** Nitrate (nitrate as N) was present in groundwater at variable levels, ranging from non-detect (< 0.1 mg/L as N) to 272 mg/L as N at H-32 in May 2019 (Appendix B). Nitrate in CCR monitoring well H-32 at 272 mg/L as N, was orders of magnitude higher than in other monitoring wells, in which nitrate ranged from non-detect (<0.1 mg/L as N) to 0.658 mg/L as N. Nitrate was not detected in Martin Lake water. Phosphate concentrations in groundwater ranged from near non-detect (0.03 mg/L as P) to 0.126 mg/L as P in CCR monitoring wells. Phosphate was not detected in the water of Martin Lake in May 2019. No spatial trend was apparent in the nitrate or phosphate distribution in groundwater.

Constituents Identified in February 2019 SSL Notification

- **Beryllium:** Beryllium concentrations in groundwater samples historically have exceeded the GWPS (0.004 mg/L) in CCR monitoring wells H-28, H-29, H-31, and H-32 on at least one occasion since October 2015 (Figure 9a). However, due to the variability of beryllium concentrations in groundwater at these wells, only H-31 currently has beryllium at an SSL. As of May 2019, beryllium concentrations in H-31 and H-32 were above the GWPS, at 0.00713 mg/L and 0.00928 mg/L, respectively. The highest beryllium concentration in groundwater was measured in H-31 in December 2016. Beryllium was not detected in the Martin Lake water sample (<0.0003 mg/L). Beryllium is likely present in groundwater as the divalent cation Be^{+2} based on the pH and Eh of groundwater (Figure 10a).
- **Cobalt:** Cobalt concentrations in groundwater samples historically have exceeded the GWPS (0.0564 mg/L) in all CCR monitoring wells except H-27 on at least one occasion since October 2015 (Figure 9b). All CCR network monitoring wells have also reported groundwater cobalt concentrations below the GWPS on at least one occasion since October 2015, indicating variability in cobalt. In May 2019, all wells except H-27 had cobalt concentrations in groundwater above the GWPS. Cobalt was not detected in water from Martin Lake in May 2019 (<0.003 mg/L). Cobalt is likely present in groundwater as the divalent cation Co^{+2} based on the pH and Eh of groundwater (Figure 10b).
- **Lithium:** Lithium concentrations in groundwater have exceeded the GWPS (0.040 mg/L) since October 2015 in four wells: H-27 (upgradient), H-28, H-31, and H-33 (Figure 9c). In May 2019, only the sample from CCR monitoring well H-31 exceeded the GWPS for lithium. Based on an evaluation of the 95% confidence intervals, the GWPS exceedances for lithium at H-27, H-28, H-31, and H-33 are not at an SSL above the GWPS. Water from Martin Lake did not contain lithium above its detection limit (<0.005 mg/L) in May 2019.

The groundwater analytical results indicate that the Ash Pond Area may be the potential source for the cobalt and/or beryllium concentrations observed at SSLs in monitoring wells H-28, H-31 and H-32. However, the data also indicates that lithium concentrations are not present at SSLs in any of the monitoring wells at the Site.

3.5 Evaluation of Soil

3.5.1 Mineralogical Composition

Quantitative X-ray diffraction (XRD) with Rietveld refinement was used to identify and quantify minerals in three overburden samples collected during the drilling activities - one sample from each of the soil borings completed in June 2019 (AP-2019-1, AP-2019-2, and AP-2019-3). These samples were obtained to better understand the mineralogical composition of the aquifer system and identify any minerals that would potentially influence attenuation of constituents of interest. In contrast, the presence of certain minerals could also indicate a potential for naturally-occurring release of metals into groundwater, for instance due to oxidation of sulfide minerals.

The mineralogical analysis of soil from borehole samples at the Ash Pond Area identified quartz as the predominant mineral, with varying amounts of albite in all three boreholes. Soil samples from boreholes AP-2019-1 and AP-2019-2 (ranging 30' below ground surface (bgs) to 31' bgs and 35' bgs to 36' bgs) also contained small or trace amounts of the silicate minerals K-felspar, chlorite, muscovite, kaolinite, vermiculite, illite, and montmorillonite. Analytical reports for the XRD samples are provided in Appendix B. These minerals were not identified in the shallower borehole samples of AP-2019-1 (18' bgs to 19' bgs), indicating potentially a greater abundance of clay minerals (kaolinite, vermiculite, illite, montmorillonite) in deeper samples.

3.5.2 Chemical Composition and Sequential Extraction

Chemical analysis and sequential extractions were used to determine the chemical composition of the soil and the distribution of constituents of interest over various operationally-defined fractions comprising the soil. Testing was completed as described in Section 3.3.2 on soil samples obtained from three borehole locations (Figure 2) and the analytical reports for the soil analyses are provided in Appendix B.

Soil sample locations were chosen to gain a better understanding of the underlying geological conditions of the area surrounding the Ash Pond Area, mostly adjacent to or downgradient of a CCR monitoring well. In addition, this information allows for a better understanding of naturally-occurring metal contributions to groundwater or the potential for sequestration of constituents from groundwater.

A description of the individual fractions determined by sequential extraction is presented in Section 3.3.2. Metals extracted in steps 1 through 5 are considered environmentally available, whereas metals extracted in steps 6 and 7 are present in refractory fractions and are not expected to be released under conditions typically encountered in aquifers (Tessier et al. 1979). Total metal quantities from the sequential extraction are expressed as "SEP Total" in Appendix B. The sum of the sequential extraction steps is also presented for comparison but does not represent an analytically-determined value.

The results from the chemical analysis and sequential extraction presented in Appendix B are summarized as follows:

General Chemistry Parameters

- **Aluminum:** Aluminum is not a constituent of interest (COI) at the site but it has been well studied as a sorbing medium in soils (e.g., Karamalidis and Dzombak 2011). Total aluminum in soils ranged from 14,244 to 33,160 mg/kg, and the environmentally-available fraction ranged from 1,044 (AP-2019-3) to 1,989 mg/kg (AP-2019-2). Aluminum in the soil at the site is, therefore, largely (~84% to 87%) present in the residual, or silicate-bound fraction. This fraction is likely at least partially represented by hydrous aluminum phyllosilicate

minerals or clays intermixed in the silica sand matrix. Clays can represent an important sorptive reservoir for numerous trace metals and metalloids (Uddin 2017).

- **Iron:** While not a COI, iron and its minerals commonly represent one of most abundant reservoirs for metal/metalloid attenuation in soils (Dzombak and Morel 1990; Smith 1999). Iron was present in all three core samples analyzed, varying from 5,192 (AP-2019-3) to 13,933 mg/kg (AP-2019-2). In all samples, the non-environmentally available (sulfide and residual) fractions accounted for the largest proportion of total iron (54% to 64%) and, as such, most of the iron is not environmentally available. The remainder of the iron in the samples is present across the exchangeable (except AP-2019-1), carbonate (only in AP-2019-2), amorphous metal, and metal hydroxide phases. These phases, part of the labile fraction in steps 1 through 5, can generally be considered representative of the amount of iron in soil that may be available as a sorbing medium and can, therefore, be important for potential attenuation of beryllium and cobalt.

Constituents Identified in February 2019 SSL Notification

- **Beryllium:** Total beryllium in soil ranged from 0.23 to 0.68 mg/kg, of which 16% to 75% of the beryllium was present in the environmentally-available fraction. The non-environmentally available fraction of beryllium (25% to 84% of total) is also indicative of naturally occurring beryllium in soil at the Ash Pond Area. All of the environmentally-available beryllium resorted in the amorphous metal and metal hydroxide fractions, indicating potential attenuation of beryllium from groundwater (Smith 1999).
- **Cobalt:** Total cobalt in soil ranged from 1.68 to 6.29 mg/kg while the environmentally-available fraction ranged from 1.4 mg/kg in AP-2019-3 to 4.39 mg/kg in AP-2019-2, representing from 58% to 83% of total cobalt. The majority of the environmentally-available cobalt was present in the metal hydroxide fractions in soils samples AP-2019-1 and AP-2019-2, while the exchangeable fraction hosted the largest proportion of cobalt in soils sample AP-2019-3. Soil sample AP-2019-2 contained cobalt in every fraction of the sequential extraction test, indicating potential attenuation of cobalt from groundwater, and the potential presence of naturally occurring cobalt in soil.
- **Lithium:** Total lithium in soil ranged from 7.15 to 17.3 mg/kg, of which between only 7% (AP-2019-3) and 24% (AP-2019-2) resorted in the environmentally-available fraction. Lithium that was environmentally available (0.53 to 4.2 mg/kg) was all contained in the metal hydroxide fraction. This indicates the likelihood of the presence of naturally-occurring lithium at the site that is contained within non-environmentally available fractions while attenuation of lithium by metal hydroxide minerals also appears to be occurring.

The results of the soil analysis indicate the following:

- A naturally-occurring source of beryllium, cobalt, and lithium is present in the vicinity of the Ash Pond Area at the MLSES.
- Attenuation of beryllium, cobalt, and lithium in groundwater is likely occurring in the vicinity of the Ash Pond Area.

3.6 Summary of Site Characterization

Based on the above site characterization and nature and extent investigation, the following is concluded with respect to beryllium, cobalt, and lithium:

- Beryllium: Beryllium concentrations statistically exceeded the GWPS in groundwater from only one CCR monitoring well (H-31). Beryllium concentrations in groundwater monitoring well H-31 were the highest in December 2016, followed by a stable or decreasing trend since that occurrence. Beryllium was not detected in water from Martin Lake. Sequential extraction results indicate the potential for attenuation of beryllium by amorphous metals and metal hydroxides (Smith 1999). Beryllium should, therefore, be considered for further evaluation as part of an ACM as a viable candidate for monitored natural attenuation based on the results of this initial assessment (USEPA 2007a, b).
- Cobalt: Historical data from CCR monitoring wells in which cobalt concentrations in groundwater exceeded the GWPS indicate a stable or decreasing concentrations since the highest measured cobalt in groundwater of 0.434 mg/L in October 2015. Cobalt concentrations in groundwater currently statistically exceed the GWPS in three CCR monitoring wells (H-28, H-31 and H-32). Cobalt was not detected in water from Martin Lake. Cobalt was present in nearly every fraction of soil as determined from sequential extraction, indicating the strong potential for cobalt attenuation by soils (Smith 1999). Cobalt should, therefore, be considered for further evaluation as part of an ACM as a viable candidate for monitored natural attenuation based on the results of this initial assessment (USEPA 2007a, b).
- Lithium: Recent data indicates that lithium concentrations in groundwater statistically no longer exceed the GWPS at any monitoring well location. Lithium was not detected in water from Martin Lake. Based on the data collected to date, lithium concentrations in groundwater are no longer considered to be present at an SSL above the GWPS; however, lithium concentrations in groundwater will continue to be monitored to confirm that lithium levels remain below the GWPS in the future. For the purposes of this ACM evaluation, lithium concentrations are conservatively assumed to be present at an SSL above the GWPS in well H-31 based on the February 2019 SSL notification.

4.0 ASSESSMENT OF CORRECTIVE MEASURES

In accordance with §257.96 and §257.97, an ACM was conducted for the Ash Ponds to address concentrations of the following Appendix IV constituents conservatively assumed to occur at SSLs above their respective GWPS based on the February 2019 SSL notification:

- cobalt concentrations in monitoring wells H-28, H-31 and H-32;
- beryllium concentrations in monitoring well H-31; and
- lithium concentrations in monitoring well H-31.

Potential response technologies were identified for Source Control (to reduce the potential for releases of constituents to groundwater) and Groundwater Response Actions (to reduce constituent concentrations below GWPS). The potential response technologies were then screened to identify options that are appropriate for further consideration in developing potential corrective measures alternatives for the Site. The results of the ACM are presented in this section.

4.1 Corrective Measures Objectives and Evaluation Criteria

As described in §257.96(a), the corrective measures must prevent further releases, remediate any releases and restore the affected area to original conditions. Potential corrective measures must meet the requirements specified in §257.97(b):

- 1) Be protective of human health and the environment;
- 2) Attain the groundwater protection standard as specified pursuant to § 257.95(h);
- 3) Control the source(s) of releases to reduce or eliminate, to the maximum extent feasible, further releases of constituents in appendix IV to this part into the environment;
- 4) Remove from the environment as much of the contaminated material that was released from the CCR unit as is feasible, considering factors such as avoiding inappropriate disturbance of sensitive ecosystems;
- 5) Comply with standards for management of wastes as specified in § 257.98(d).

In accordance with §257.96(c), the assessment of potential corrective measures alternatives must include an evaluation of the following:

- 1) The performance, reliability, ease of implementation, and potential impacts of appropriate potential remedies, including safety impacts, cross-media impacts, and control of exposure to any residual contamination
- 2) The time required to begin and complete the remedy
- 3) Institutional requirements, such as state or local permit requirements or other environmental or public health requirements that may substantially affect implementation of the remedy(s).

4.2 Potential Source Control Response Technologies

One of the listed objectives in §257.97(b) for the corrective measures is to control the source of releases of Appendix IV constituents to the environment from the CCR Unit. The MLSES Ash Ponds are an integral part of

the CCR management system at the plant. As a result, any potential source control technology must keep the WAP, EAP and NSP in operation.

The WAP, EAP and NSP are considered unlined surface impoundments under the CCR Rule. As a result, the WAP, EAP and NSP will be retrofitted with new composite liner systems that comply with the requirements of §257.71(a)(1)(ii) of the CCR Rule to improve the level of source control in the ponds. The new liner systems will be installed in general accordance with the following procedures:

- The ponds will be retrofitted one at a time;
- Water will be removed from the pond being retrofitted and transferred to the other Ash Ponds;
- Solids in the ponds will be dewatered, removed and transported to the MLSES A1 Area Landfill for disposal.
- A minimum of 2 feet of compacted clay liner will be placed at the base of each pond;
- A 60-mil HDPE geomembrane liner will be installed over the 2 feet of compacted clay liner;
- A protective layer of soil, ash or other material will be placed over the geomembrane liner.

Retrofitting the WAP, EAP and NSP with new composite liner systems is assumed to serve as the source control component of the potential corrective measures for the Ash Ponds. The estimated time to retrofit the WAP, EAP and NSP is estimated to be approximately 1 to 2 years per pond, including design and construction.

4.3 Potential Groundwater Response Technologies

For the purposes of this ACM, cobalt, beryllium and lithium are conservatively assumed to be present in groundwater at the Site at SSLs above their respective GWPS based on the February 2019 SSL notification. In this section, potential groundwater response technologies to address these constituents are identified and screened for further consideration in developing potential corrective measures alternatives for the Ash Ponds.

4.3.1 Monitored Natural Attenuation

Monitored natural attenuation (MNA) refers to the reliance on natural attenuation processes (within the context of a carefully controlled and monitored site cleanup approach) to achieve site-specific groundwater remediation objectives within a time frame that is reasonable compared to that offered by more active remediation methods (USEPA 2007a). MNA relies on a range of natural processes, including dispersion, dilution, sorption, (co)precipitation, radioactive decay, and abiotic degradation/transformation to achieve remediation objectives (ITRC 2010). Routine groundwater monitoring would be required to verify MNA is occurring at the Site.

Where necessary, MNA processes can be enhanced through the use of low-energy, in-situ techniques to stimulate or increase the attenuation of contaminants or reduce contaminant loading (ITRC 2010). Enhancement options include increasing the attenuation capacity of the aquifer, decreasing the mobility of contaminants, and/or increasing the stability of immobilized contaminants by increasing the ability of aquifer solids to remove contaminants from groundwater and/or manipulating the geochemistry to reduce remobilization of contaminants by desorption or dissolution of precipitates (ITRC 2010).

MNA has been demonstrated effective in reducing cobalt and beryllium concentrations in groundwater (ITRC 2010; USEPA 2007b). Cobalt is removed through adsorption to iron hydroxides and/or amorphous metals and the level of effectiveness is dependent on iron hydroxide availability as well as pH, alkalinity, and calcium levels (ITRC 2010). Beryllium is removed through adsorption or coprecipitation (DOD 2014). The removal mechanisms for lithium are not identified in the professional literature. As described in Section 3.6 of this report, the Site is a good candidate for MNA, since natural attenuation of cobalt, lithium and beryllium is ongoing at the Site.

MNA would be effective in remediating groundwater beneath and downgradient of the Ash Ponds. The estimated time to implement MNA is estimated to be approximately 2 to 3 years, including characterization, design, and construction. The estimated time to achieve GWPS for the target Appendix IV constituents is dependent on site-specific conditions and groundwater modelling is needed to evaluate remedial timeframes.

4.3.2 Groundwater Extraction and Treatment

Groundwater extraction and treatment is one of the most widely implemented groundwater remediation technologies and is used to provide 1) hydraulic containment and 2) treatment (USEPA 1996). A groundwater extraction and treatment system consists of the following major components:

- A series of extraction wells or trenches strategically located to modify/interrupt the natural flow of groundwater;
- Extraction pumps installed in each well/trench to pump groundwater from the subsurface;
- A treatment system to remove constituents of concern from the extracted groundwater; and
- A point of discharge for the treated groundwater (surface water, re-injection to groundwater, etc.).

For the Ash Ponds, a system of extraction wells would be installed along the downgradient edge of the ponds to provide hydraulic control of the Appendix IV constituent groundwater plumes. The extracted groundwater would be treated in an on-site treatment system and treated water would be discharged to Martin Lake or re-injected into the aquifer.

Potential groundwater treatment methods for the target Appendix IV constituents include the following:

- Cobalt - ion exchange, adsorptive media, activated carbon, and chemical treatment with membrane filtration (USEPA 2019a).
- Lithium - reverse osmosis, precipitation/co-precipitation, and ion exchange. (USACE, 2010).
- Beryllium - activated alumina, ion exchange, lime softening, coagulation/filtration, and reverse osmosis (USEPA 2003)

Treatment methods for these constituents would need to be bench/pilot tested to evaluate their effectiveness prior to designing a full-scale system. Treatment will generate residual material (sludge, regenerate brine, etc.) containing concentrated levels of the target Appendix IV constituents that must be managed.

Groundwater extraction and treatment would be effective in reducing contaminant concentrations in groundwater downgradient of the Ash Ponds through hydraulic containment, but would have little effect on groundwater conditions beneath the ponds. The estimated time to implement groundwater extraction and treatment is estimated to be approximately 3 to 4 years, including testing, design, and construction. The estimated time to achieve GWPS for the target Appendix IV constituents is dependent on site-specific conditions and groundwater modeling is needed to better evaluate remedial timeframes.

4.3.3 Vertical Hydraulic Barrier

A vertical, low permeability hydraulic barrier can be installed to provide a physical barrier to groundwater flow to contain the migration of contaminated groundwater. Vertical hydraulic barriers that have been demonstrated effective at controlling groundwater flow include the following (USEPA 1998):

- **Slurry Wall.** Slurry walls consist of a narrow, excavated trench that is filled with a soil-bentonite slurry mixture. The slurry shores and supports the trench walls and forms a low-permeability barrier in the trench. Key design considerations include wall depth, key depth, and material compatibility. Slurry trenches can be excavated to depths of 50 feet using standard excavators and over 80 feet using long-reach excavators or a crane mounted drag line/clamshell bucket. Geosynthetic materials can be placed in the trench in conjunction with the slurry wall to improve the hydraulic performance (decrease permeability) and chemical resistance.
- **Soil-Mixed Wall.** Soil-mixed walls form a hydraulic barrier through in-situ mixing of soil with amendments, such as bentonite and/or cement. Soil-mixed barrier walls can be installed to depths of over 100 feet. The walls are installed by sections or panels that overlap to achieve a continuous barrier.
- **Grout Curtain.** Grout curtain barriers are constructed by injecting grout into the subsurface in an overlapping injection pattern to form a continuous barrier. Grouted barriers can be installed using permeation grouting, jet grouting, or vibrating beam technologies. Grouted barriers must be designed and constructed to ensure hydrofracturing does not occur and the completed wall is effective at restricting groundwater flow.
- **Sheet-pile Wall.** Sheet-pile walls consist of steel, vinyl, or other materials driven into the subsurface using a hydraulic percussion hammer or vibratory hammer. Sheet-pile walls are common in civil engineering applications; however, their use in environmental applications has been more limited. One of the major concerns with sheet-walls in environmental applications is leakage through the vertical joints between piles; however, improvements in pile interlock designs have been made to improve joint sealing.

For a vertical hydraulic barrier to be effective, the bottom of the barrier must be “keyed” into a low-permeability confining layer. A detailed engineering analysis and design, likely including a bench/pilot test to identify most appropriate barrier materials, would be required for the construction of a vertical hydraulic barrier.

For the Ash Ponds, the vertical hydraulic barrier would be constructed along the downgradient edge of the ponds to provide hydraulic control of the target Appendix IV constituent groundwater plumes. A vertical hydraulic barrier physically interrupts the natural flow of groundwater; consequently, groundwater elevations upgradient of the barrier will rise, potentially to the point that groundwater could begin to flow around the edges of the barrier. To address this concern, a groundwater extraction and treatment system would be required upgradient of the barrier to control the groundwater levels. The groundwater extraction and treatment system used in conjunction with the vertical hydraulic barrier would be similar to the system described in Section 4.3.2; however, the required capacity of the system would be less since the rate of groundwater extraction would be limited to that required to control upgradient groundwater levels.

Construction of a vertical hydraulic barrier is expected to require significant effort and time. Prior to implementation of the barrier, pre-design field work, including site investigations and bench/pilot-scale barrier material testing would be required, followed by full-scale design and construction. The estimated time to

implement a vertical hydraulic barrier with groundwater extraction and treatment is estimated to be approximately 5 to 8 years, including testing, design, and construction. The estimated time to achieve GWPS for the target Appendix IV constituents is dependent on site-specific conditions and groundwater modeling is needed to better evaluate remedial timeframes.

4.3.4 Permeable Reactive Barrier

A permeable reactive barrier (PRB) is an in-situ, permeable treatment zone that contains reactive media designed to intercept impacted groundwater and either immobilize contaminants or transform the contaminants to a more desirable state (ITRC 2011). A PRB is a passive treatment system that acts as a barrier to groundwater contamination but not groundwater flow. The PRB must intercept the flow of impacted groundwater and must be designed and constructed such that impacted groundwater cannot bypass the reactive media by flowing over, under, or around the PRB. A PRB must include the appropriate reactive media and the residence time within the PRB needs to be sufficient to allow for effective treatment. The effectiveness of the reactive media will be reduced over time and the media will likely have to be replaced periodically. Groundwater monitoring is used to evaluate the performance/effectiveness of a PRB system.

There are two primary PRB configurations: continuous and funnel-and-gate. A continuous PRB features permeable reactive media across the entire length of the barrier. A funnel-and-gate PRB uses sections of vertical hydraulic barriers to direct groundwater flow through permeable reactive media sections that allow the groundwater to pass through while treating contaminants. In both configurations, the permeability of the reactive media must be greater than the aquifer to ensure flow is not diverted around the PRB media. For the ash Ponds, a PRB system would be constructed along the downgradient edge of the ponds to provide control of the target Appendix IV groundwater plumes.

PRB systems are generally considered a proven technology, however, site conditions and the specific contaminants of interest affect the system performance. The potential applicability of a PRB system for the target Appendix IV constituents can be summarized as follows:

- Cobalt - potentially removed using sulfate-reducing media or combination of zero-valent iron (ZVI) and organic material (Ludwig 2002; ITRC 2011);
- Lithium – potentially precipitated as phosphate using phosphate media, (Arnseth 2018).
- Beryllium – potentially removed through in-situ biomass sorption (Goldmund and Robb 2018)

Removal of the target Appendix IV constituents using a PRB system has not been consistently demonstrated under full-scale conditions and bench/pilot-scale testing would be required to confirm the effectiveness of a PRB system at the Site. A groundwater model would be needed to evaluate the remedial timeframes.

Similar to a vertical hydraulic barrier, construction of a PRB system is expected to require significant effort and time. Prior to implementation of the PRB, pre-design field work, including site investigations, groundwater modeling, and bench-scale soil mix testing would be required, followed by full-scale design and construction. The estimated time to implement a PRB system is estimated to be approximately 5 to 8 years, including testing, design, and construction. The estimated time to achieve GWPS for the target Appendix IV constituents is dependent on site-specific conditions and groundwater modeling is needed to better evaluate remedial timeframes.

4.3.5 In-situ Chemical Treatment

In-situ Chemical Treatment (ICT) involves the injection of a chemical reagent or other material into the groundwater aquifer to adjust the geochemistry to enhance the direct precipitation, co-precipitation, or related adsorption/precipitation of the target contaminants (USEPA 2019c). Direct precipitation occurs when a constituent exceeds its solubility in water and precipitates out of solution. Co-precipitation refers to the removal of a constituent through adsorption onto the precipitate of another chemical reaction.

Cobalt has the potential to be removed through adsorption and/or coprecipitation under reducing groundwater conditions and beryllium can potentially be removed through in-situ biomass sorption (Goldmund and Robb 2018). Lithium has the potential to be precipitated as a phosphate under appropriate geochemical conditions (Arnseth 2018).

Injection wells would be installed into the aquifer along the downgradient edge of Ash Ponds and the chemical reagents would be injected to provide control of the target Appendix IV constituent groundwater plumes.

ICT is considered an emerging remediation technology for the target Appendix IV constituents and the effectiveness of the technology on most of the constituents is uncertain. Bench/pilot-scale testing would be required to confirm the effectiveness of an ICT system at the Site. The estimated time to implement an ICT system is estimated to be approximately 5 to 8 years, including testing, design, and construction. The estimated time to achieve GWPS for the target Appendix IV constituents is dependent on site-specific conditions and groundwater modeling is needed to better evaluate remedial timeframes.

4.3.6 Phytoremediation

Phytoremediation refers to the use of plants to partially or substantially remediate selected contaminants in contaminated soil, sludge, sediment, ground water, surface water, and wastewater (USEPA 2001). The process utilizes a variety of plant biological processes and plant physical characteristics to aid in remediation; however, the primary plant process potentially applicable to the target Appendix IV constituents at the Site is phytoextraction, which is the uptake and accumulation of contaminants within aboveground portions of a plant. The contaminants are removed from the Site when the plants are harvested and managed off-site.

Phytoextraction occurs in the root zone of plants, which is typically relatively shallow, with the bulk of roots at shallower rather than deeper depths. This would limit the effectiveness of phytoextraction at the Site due to the depth of groundwater. Phytoremediation for cobalt removal from groundwater has not been demonstrated under full-scale conditions and no information concerning the effectiveness of phytoremediation for lithium and beryllium removal was identified (USEPA 2001).

Implementation of a phytoremediation process at the Site would involve planting appropriate vegetation at intervals along the downgradient edge of the Ash Ponds and across the affected groundwater plume area. A comprehensive bench/pilot testing program would be required to select the most appropriate plants for removal of the target Appendix IV constituents from groundwater at the Site. Since the target Appendix IV constituents would likely accumulate in the plants, management of harvested plants in accordance with RCRA may be required. The estimated time to implement an ICT system is estimated to be approximately 15 to 20 years, based on the success and rate of vegetation growth. The estimated time to achieve GWPS for the target Appendix IV constituents is dependent on site-specific conditions and groundwater modeling is needed to better evaluate remedial timeframes.

4.3.7 Screening of Potential Groundwater Response Technologies

Following identification of potential groundwater response technologies, Golder screened the potential options for further consideration in developing potential corrective measures alternatives for the Ash Ponds. The screening results for each potential source technology are summarized in Table 3. Based on the initial screening, the following potential groundwater response technologies were retained for future evaluation as part of the corrective measures alternatives for the Ash Ponds:

- Monitored Natural Attenuation
- Groundwater Extraction and Treatment
- Vertical Hydraulic Barrier

4.4 Potential Corrective Measures Alternatives

Based on the response technology screening discussed above, Golder assembled the following potential corrective measures alternatives that could be both effective and implementable at the Site:

- Retrofit Liners in WAP, EAP and NSP with Monitored Natural Attenuation
- Retrofit Liners in WAP, EAP and NSP with Groundwater Extraction and Treatment
- Retrofit Liners in WAP, EAP and NSP with Vertical Hydraulic Barrier

A summary of the corrective measure alternatives, including an assessment of each alternative against the evaluation criteria presented in §257.96(c) is provided in Table 4.

4.5 Remedy Selection

The corrective measure alternative proposed as the remedy for the Ash Ponds will be selected in accordance with §257.97 a minimum of 30 days after the public meeting required under §257.96(e) has been completed.

It should also be noted that, for the purposes of this ACM, cobalt, beryllium and lithium concentrations were conservatively assumed to be present at SSLs above their respective GWPSs based on the February 2019 SSL notification. However, as discussed in Sections 3.4-3.6, lithium concentrations are no longer considered to be present at SSLs above the GWPS based on recent data and naturally occurring sources of cobalt, beryllium and lithium exist in the vicinity of the Ash Ponds. Cobalt, beryllium and lithium concentrations in groundwater will continue to be monitored in accordance with the CCR rule to confirm that the concentrations of these constituents remain below the GWPSs in the future. These monitoring results, along with updated statistical analysis and alternate source demonstrations (if applicable), will be considered as part of the remedy selection process.

5.0 REFERENCES

- Arnseth, Richard W., 2018. Remedial Technologies to Address CCR Constituents in Groundwater, Tennessee Department of Environmental Conservation - Environmental Show of the South, May.
- Barnes, Virgil E., 1965. Geologic Atlas of Texas, Tyler Sheet. Texas Bureau of Economic Geology.
- Bethke, C., 2015. Geochemist's Workbench: Release 12.0 - Aqueous Solutions, LLC.
- Burns & McDonnell Engineering Company, Inc (BM), 2016. Summary of Liner Construction – Martin Lake Impoundments, Martin Lake Steam Electric Station. September.
- Code of Federal Regulations, 2015 April. Chapter 40, Part 257, Subpart D.
- Dzombak, D.A. and Morel, F., 1990. Surface complexation modeling: hydrous ferric oxide. John Wiley & Sons.
- Goldmund, H and Robb, C, 2018. Current Overview of Groundwater Remediation Options for CCR Units, Proceedings of 2018 World of Coal Ash Conference.
- Golder, 2019. Drinking Water Survey Report – Revision No. 1, Martin Lake Steam Electric Station – Ash Pond Area and PDP 5, Rusk County, Texas. July 25.
- Hem, J.D., 1985. Study and interpretation of the chemical characteristics of natural water (Vol. 2254). US Geological Survey.
- ITRC. 2010. A Decision Framework for Applying Monitored Natural Attenuation Processes to Metals and Radionuclides in Groundwater. Technical/Regulatory Guidance, December 2010.
- ITRC. 2011. Permeable Reactive Barrier: Technology Update. PRB-5. June 2011.
- Karamalidis, A. and Dzombak, D., 2011. Surface complexation modeling: gibbsite. John Wiley & Sons.
- Ludwig, R, et. al., 2002. A Permeable Reactive Barrier for Treatment of Heavy Metals in Ground Water 40(1):59-66, January 2002.
- Parkhurst, D. and Appelo, C., 2013. Description of input and examples for PHREEQC version 3: a computer program for speciation, batch-reaction, one-dimensional transport, and inverse geochemical calculations (No. 6-A43). US Geological Survey.
- Pastor, Behling & Wheeler, LLC (PBW), 2011. Revised Affected Property Assessment Report, Martin Lake Steam Electric Station – Ash Pond Area (TCEQ SWR No. 31277). May 3.
- PBW, 2017a. Coal Combustion Residual Rule Groundwater Monitoring System Certification, Martin Lake Steam Electric Station, Ash Pond Area, Rusk County, Texas. October 16
- PBW 2017b. Coal Combustion Residual Rule Statistical Analysis Plan, Martin Lake Steam Electric Station, Ash Pond Area, Freestone County, Texas.
- Smith, K., 1999. Metal sorption on mineral surfaces: an overview with examples relating to mineral deposits. The Environmental Geochemistry of Mineral Deposits. Part B: Case Studies and Research Topics, 6, pp.161-182.

- Tessier, A., Campbell, P.G. and Bisson, M., 1979. Sequential extraction procedure for the speciation of particulate trace metals. *Analytical chemistry*, 51(7), pp.844-851.
- Uddin, M., 2017. A review on the adsorption of heavy metals by clay minerals, with special focus on the past decade. *Chemical Engineering Journal*, 308, pp.438-462.
- US Department of Defense (DOD), 2014. Frequently Asked Questions about Monitored Natural Attenuation in Groundwater, February.
- USEPA, 1996. Pump-and-Treat Ground-Water Remediation: A Guide for Decision Makers and Practitioners. EPA/625/R-95/005. July 1996.
- USEPA. 1998. Evaluation of Subsurface Engineered Barriers at Waste Sites, EPA-542-R-98-005, July 1998.
- USEPA. 2001. Phytoremediation of Contaminated Soil and Ground Water at Hazardous Waste Sites, EPA/540-S-01/500. February 2001.
- USEPA. 2003. Water Treatment Technology Feasibility Support Document for Chemical Contaminants, EPA 815-R-03-004, June.
- USEPA, 2007a. Monitored Natural Attenuation of Inorganic Contaminants in Ground Water. Volume 1. Technical Basis for Assessment. EPA/600/R-07/139.
- USEPA, 2007b. Monitored Natural Attenuation of Inorganic Contaminants in Ground Water. Volume 2. Assessment for Non-Radionuclides Including Arsenic, Cadmium, Chromium, Copper, Lead, Nickel, Nitrate, Perchlorate, and Beryllium. EPA/600/R-07/140.
- USEPA, 2009. Unified Guidance Document: Statistical Analysis of Groundwater Monitoring Data at RCRA Facilities, EPA 530-R-09-007, March 2009.
- USEPA, 2014. Reference Guide to Treatment Technologies for Mining-Influenced Water. March 2014.
- USEPA, 2015. 40 CFR Parts 257 and 261; Hazardous and Solid Waste Management System; Disposal of Coal Combustion Residuals from Electric Utilities; Final Rule. April 17, 2015.
- USEPA, 2015. Use of Monitored Natural Attenuation for Inorganic Contaminants in Groundwater at Superfund Sites. U.S. Environmental Protection Agency Office of Solid Waste and Emergency Response Directive 9283.1-36. August 2015.
- USEPA, 2019a. Drinking Water Treatability Database – Cobalt and Beryllium. Retrieved from <https://oaspub.epa.gov/tdb/pages/general/home.do>
- USEPA, 2019b. Permeable Reactive Barriers. CLU-IN. Retrieved from https://clu-in.org/techfocus/default.focus/sec/Permeable_Reactive_Barriers%2C_Permeable_Treatment_Zones%2C_and_Application_of_Zero-Valent_Iron/cat/Overview/
- USEPA, 2019c. In Situ Chemical Reduction. CLU-IN. Retrieved from https://clu-in.org/techfocus/default.focus/sec/In_Situ_Chemical_Reduction/cat/Overview/

Signature Page

Golder Associates Inc.



Patrick J. Behling, P.E.
Principal Engineer



William F. Vienne, P.G.
Senior Hydrogeologist

Golder and the G logo are trademarks of Golder Associates Corporation.

[https://golderassociates.sharepoint.com/sites/114142/project files/5 technical work/phase 1000 - ml ash pond area/ccr acm ml ses ash pond area_9-5-19.docx](https://golderassociates.sharepoint.com/sites/114142/project%20files/5%20technical%20work/phase%201000%20-%20ml%20ash%20pond%20area/ccr%20acm%20mlses%20ash%20pond%20area_9-5-19.docx)

LUMINANT

TABLES

TABLE 1
APPENDIX IV GROUNDWATER ANALYTICAL DATA SUMMARY
MARTIN LAKE STEAM ELECTRIC STATION
ASH POND AREA

Sample Location	Date Sampled	Sb (mg/L)	As (mg/L)	Ba (mg/L)	Be (mg/L)	Cd (mg/L)	Cr (mg/L)	Co (mg/L)	Fl (mg/L)	Pb (mg/L)	Li (mg/L)	Hg (mg/L)	Mo (mg/L)	Se (mg/L)	Tl (mg/L)	Ra 226 (pCi/L)	Ra 228 (pCi/L)	Ra 226/228 Comb.^ (pCi/L)
GWPS:		0.006	0.01	2	0.004	0.005	0.1	0.0564	4	0.015	0.177	0.002	0.1	0.05	0.002	--	--	5
H-31	10/20/15	<0.0008	0.0168	0.0732	0.0126	0.0032	0.00687	0.434	0.889	<0.0003	0.137	<0.00008	<0.002	0.116	<0.0005	0.943	<1.88	2.82
	12/14/15	<0.0008	0.00513	0.0388	0.00702	<0.0003	0.00456 J	0.0651	0.692	<0.0003	0.149	<0.00008	<0.002	0.0231	<0.0005	1.61	<1.29	2.90
	02/23/16	<0.0008	0.00436 J	0.0243	0.0101	<0.0003	<0.002	0.0594	0.921	<0.0003	0.146	<0.00008	<0.002	0.0209	<0.0005	<0.419	<1.64	<2.059
	04/05/16	<0.0008	0.00514	0.0241	0.00925	<0.0003	0.00435 J	0.0685	1.36	<0.0003	0.146	<0.00008	<0.002	0.0226	<0.0005	<0.334	<0.897	<1.231
	06/07/16	<0.0008	0.0038 J	0.0242	0.00789	<0.0003	<0.002	0.0406	0.783	<0.0003	0.157	<0.00008	<0.002	0.0307	<0.0005	0.257	<0.555	0.81
	08/09/16	<0.0008	0.00886	0.0191	0.00734	<0.0003	<0.002	0.286	0.216 J	<0.0003	0.17	<0.00008	<0.002	0.0202	<0.0005	1.31	0.900	2.21
	10/18/16	<0.0008	0.00351 J	0.0215	0.00167 J	<0.0003	<0.002	0.0304 J	0.298 J	<0.0003	0.165	<0.00008	<0.002	0.00567 J	<0.0005	0.169	1.18	1.35
	12/11/16	<0.0008	0.00875 J	0.0189	0.0197	<0.0003	0.00386 J	0.23 J	0.892	<0.0003	0.198	<0.00008	<0.002	0.0365	<0.0005	0.195	<0.754	0.95
	06/12/18	<0.0008	0.00532	0.0194	0.00545	<0.0003	0.003 J	0.236	0.646	<0.0003	0.214	<0.00008	<0.002	0.00475 J	<0.0005	<0.26	<0.597	<0.857
	09/07/18	NA	<0.002	0.0287	<0.0003	<0.0003	<0.002	0.00353 J	0.275 J	<0.0003	0.0187	NA	NA	0.00424 J	NA	<0.261	<0.567	<0.828
05/14/19	<0.0008	0.00675	0.0163	0.00928	<0.0003	0.00315 J	0.389	0.96	<0.0003	0.219	<0.0004	<0.002	0.0261	<0.0005	2.62	<0.789	3.409	
H-32	10/20/15	<0.0008	0.0028 J	0.16	0.00266	<0.0003	<0.002	0.163	0.374 J	<0.0003	0.0788	<0.00008	<0.002	0.00303 J	<0.0005	1.05	<1.90	2.95
	12/14/15	<0.0008	0.0123	0.0384	0.00313	<0.0003	<0.002	0.155	0.619	<0.0003	0.0733	<0.00008	<0.002	<0.002	<0.0005	0.712	<2.21	2.92
	02/23/16	<0.0008	0.00712	0.0277	0.00452	<0.0003	<0.002	0.188	0.701	0.000326 J	0.0821	<0.00008	<0.002	<0.002	<0.0005	1.12	1.60	2.72
	04/05/16	<0.0008	0.00648	0.0237	0.00527	0.00128	<0.002	0.208	1.05	0.00182	0.0818	<0.00008	<0.002	<0.002	<0.0005	<0.364	<1.15	<1.514
	06/07/16	<0.0008	0.00446 J	0.0238	0.00583	0.000997 J	<0.002	0.207	0.858	0.00168	0.087	<0.00008	<0.002	0.00298 J	<0.0005	<0.165	0.613	0.778
	08/09/16	<0.0008	0.00344 J	0.0234	0.00548	0.000713 J	<0.002	0.19	0.68	0.00115	0.0774	<0.00008	<0.002	0.00281 J	<0.0005	2.56	<0.446	3.01
	10/18/16	<0.0008	0.00289 J	0.02	0.00567	0.00254	<0.002	0.204	0.904	0.00332	0.0834	<0.00008	<0.002	0.00267 J	<0.0005	<0.139	0.683	0.82
	12/11/16	<0.0008	0.00246 J	0.0205	0.00609	0.00108	<0.002	0.208	1	0.00137	0.0838	<0.00008	<0.002	0.00237 J	<0.0005	<0.163	<0.753	<0.916
	06/12/18	<0.0008	<0.002	0.0175	0.00681	0.000586 J	<0.002	0.215	1.02	0.000701 J	0.0957	<0.00008	<0.002	<0.002	<0.0005	<0.275	0.917	1.192
	09/07/18	NA	<0.002	0.0404	<0.0003	<0.0003	<0.002	0.00347 J	0.551	<0.0003	0.0195	NA	NA	0.0157	NA	0.343	1.25	1.593
05/14/19	<0.0008	0.002 J	0.0162	0.00713	0.000366 J	<0.002	0.202	1.15	0.000574 J	0.0978	<0.00008	<0.002	0.00675	<0.0005	0.303	<0.546	<0.849	

Notes:

1. Abbreviations: GWPS - groundwater protection standard; mg/L - milligrams per liter; pCi/L - picocuries per liter.
2. ^ - Sum of Ra 226 and Ra 228 concentrations. Non-detect isotope results were assigned a value equal to the minimum detectable concentration.
3. J - concentration is below method quantitation limit; result is an estimate.
4. NA = Not analyzed.

Table 2
Screening of Potential Groundwater Response Technologies
Martin Lake Steam Electric Station
Ash Ponds

Groundwater Response Technology	Description	Protective of Human Health and Environment	Attain Groundwater Protection Standard	Control Source of Release	Remove Contaminated Material From Environment	RCRA Compliance	Screening Comments	Retained for Further Evaluation
Monitored Natural Attenuation	Natural processes (dispersion, dilution, sorption, coprecipitation, degradation/transformation, etc.) remove CCR constituents from groundwater in-situ. Groundwater monitoring to verify MNA effectiveness.	Migration of CCR constituents in groundwater controlled and CCR concentrations in groundwater reduced.	CCR constituents removed through adsorption, precipitation or coprecipitation. CCR constituents removed from groundwater and retained in aquifer soil matrix to achieve GWPS below and downgradient of CCR Unit.	CCR constituents removed from groundwater below and downgradient of CCR Unit.	CCR constituents removed from groundwater and retained in aquifer soil matrix.	Purge water from groundwater monitoring requires management in accordance with applicable RCRA requirements.	Site is good MNA candidate for CCR constituents based on field MNA evaluation. Long-term groundwater monitoring required. Easy to implement. Groundwater modelling required to assess remediation timeframe.	Yes
Groundwater Extraction and Treatment	System of extraction wells along downgradient edge of ponds to provide hydraulic control of CCR constituent groundwater plumes. Extracted groundwater treated in an on-site treatment system and discharged to Martin Lake or re-injected into aquifer. Groundwater monitoring to verify system effectiveness.	Migration of CCR constituents in groundwater controlled.	GWPS attained downgradient of CCR Unit, but limited effect on concentrations beneath unit.	CCR groundwater constituents contained at edge of ponds.	CCR constituents removed from extracted groundwater by treatment system. Treatment residuals (sludge, regenerate brine, etc.) require management.	Treatment residuals (sludge, regenerate brine, etc.) require management in accordance with applicable RCRA requirements.	Regulatory authorization for treated water discharge required. Bench/pilot testing of treatment system required. Groundwater modelling required to assess remediation timeframe.	Yes
Vertical Hydraulic Barrier	Vertical, low permeability hydraulic barrier along downgradient edge of ponds to provide hydraulic control of CCR constituent groundwater plumes. Groundwater extraction and treatment required upgradient of barrier to control groundwater elevations. Groundwater monitoring to verify system effectiveness.	Migration of CCR constituents in groundwater controlled.	GWPS attained downgradient of CCR Unit, but limited effect on concentrations beneath unit.	CCR groundwater constituents contained at edge of ponds.	CCR constituents removed from extracted groundwater by treatment system. Treatment residuals (sludge, regenerate brine, etc.) require management.	Excavated soil generated from barrier installation requires testing and management as necessary. Treatment residuals (sludge, regenerate brine, etc.) require management in accordance with applicable RCRA requirements.	Bench/pilot test of barrier materials likely required. Regulatory authorization for treated water discharge required. Bench/pilot testing of treatment system required. Groundwater modelling required to assess remediation timeframe.	Yes

Groundwater Response Technology	Description	Protective of Human Health and Environment	Attain Groundwater Protection Standard	Control Source of Release	Remove Contaminated Material From Environment	RCRA Compliance	Screening Comments	Retained for Further Evaluation
Permeable Reactive Barrier	In-situ, passive, permeable treatment zone containing reactive media designed to intercept impacted groundwater and adjust geochemistry to immobilize CCR contaminants. CCR constituents removed from groundwater through adsorption and/or coprecipitation under reducing groundwater conditions. PRB acts as a barrier to groundwater contamination but not groundwater flow. Groundwater monitoring to verify system effectiveness.	Migration of CCR constituents in groundwater controlled.	GWPS attained downgradient of CCR Unit, but limited effect on concentrations beneath unit.	CCR groundwater constituents removed from groundwater downgradient of CCR Unit.	CCR constituents removed from groundwater and retained on reactive media or aquifer soil matrix.	Excavated soil generated from PRB installation requires testing and management as necessary.	CCR constituent removal using PRB possible but full-scale performance uncertain. Reactive media effectiveness reduced over time and media likely replaced periodically. Bench/pilot testing of PRB media/system required. Groundwater modelling required to assess remediation timeframe.	No
In-Situ Chemical Treatment	Injection of chemical/material into aquifer to adjust geochemistry and enhance precipitation, coprecipitation, or indirect adsorption of CCR constituents. CCR constituents potentially removed through adsorption, precipitation and/or coprecipitation. Groundwater monitoring to verify system effectiveness.	Migration of CCR constituents in groundwater controlled.	GWPS attained downgradient of CCR Unit, but limited effect on concentrations beneath unit.	CCR groundwater constituents removed from groundwater downgradient of CCR Unit.	CCR constituents removed from groundwater and retained on aquifer soil matrix.	No significant RCRA compliance issues anticipated.	ICT considered emerging remediation technology for CCR constituents - not demonstrated under full-scale conditions. Bench/pilot-scale testing of ICT system required. Groundwater modelling required to assess remediation timeframe.	No
Phytoremediation	Use of plants to remove CCR constituents through uptake and accumulation within above ground portions of the plant. Primary plant process for CCR constituent removal is phytoextraction (uptake/accumulation of contaminants within aboveground portions of a plant). Groundwater monitoring to verify system effectiveness.	Migration of CCR constituents in groundwater controlled.	GWPS attained downgradient of CCR Unit, but limited effect on concentrations beneath unit.	CCR groundwater constituents removed from groundwater downgradient of CCR Unit.	CCR constituents removed from groundwater and accumulates in plants.	Management of harvested plants in accordance with RCRA may be required if accumulated CCR constituent concentrations are high.	Phytoextraction occurs in shallow root zone of plants, which limits the effectiveness for the groundwater depths at the Site. Phytoremediation for CCR constituent removal from groundwater has not been demonstrated under full-scale conditions. Bench/pilot-scale testing of phytoremediation system required. Groundwater modelling required to assess remediation timeframe.	No

Table 3
Evaluation of Corrective Measures Alternatives
Martin Lake Steam Electric Station
Ash Ponds

Corrective Measures Alternative	Description	Performance	Reliability	Ease of Implementation	Potential Impacts	Time Requirements	Institutional Requirements
Retrofit Liners in WAP, EAP and NSP with Monitored Natural Attenuation	New Liners in WAP, EAP and NSP. MNA to remove CCR constituents from groundwater and control migration. Groundwater monitoring to verify MNA effectiveness.	New Liners in WAP, EAP and NSP isolate CCR material in pond and mitigate on-going source of CCR constituents to groundwater. Site is good MNA candidate for CCR constituents based on MNA field evaluation.	Liner construction is a common and effective source control technology. On-going attenuation of CCR constituents in groundwater demonstrated during MNA field evaluation. Groundwater monitoring used to verify long-term MNA effectiveness.	Readily implementable with common construction techniques.	Source controlled through pond liner systems. CCR constituents removed from groundwater beneath and downgradient of ponds.	Retrofit Implementation: 1-2 years per pond. MNA Implementation: 2-3 years. Groundwater modelling required to assess remediation timeframe.	Minimal regulatory requirements.
Retrofit Liners in WAP, EAP and NSP with Groundwater Extraction and Treatment	New Liners in WAP, EAP and NSP. System of extraction wells along downgradient edge of ponds to provide hydraulic control of CCR constituent groundwater plumes. Extracted groundwater treated in an on-site treatment system and discharged to Martin Lake or re-injected into aquifer. Groundwater monitoring to verify system effectiveness.	New Liners in WAP, EAP and NSP isolate CCR material in pond and mitigate on-going source of CCR constituents to groundwater. Migration of CCR constituents in groundwater controlled at pond boundaries by extraction wells.	Liner construction is a common and effective source control technology. Groundwater extraction and treatment is a common and effective hydraulic control technology. Treatment system operational reliability is key component of overall reliability.	Readily implementable with common construction techniques. Bench/pilot testing of treatment system required. Regulatory authorization for treated water discharge could be difficult to obtain.	Source controlled through pond liner systems. Control of CCR constituent migration downgradient of ponds by extraction wells. Extraction system does not address groundwater beneath ponds.	Retrofit Implementation: 1-2 years per pond. GW Ext/Treatment Implementation: 3-4 years. Groundwater modelling required to assess remediation timeframe.	Regulatory authorization for treated water discharge required. Treatment system residuals (sludge, regenerate brine, etc.) require management.
Retrofit Liners in WAP, EAP and NSP with Vertical Hydraulic Barrier and Groundwater Extraction and Treatment	New Liners in WAP, EAP and NSP. Vertical, low permeability hydraulic barrier along downgradient edge of ponds to provide hydraulic control of CCR constituent groundwater plumes. Groundwater extraction and treatment required upgradient of barrier to control groundwater elevations. Groundwater monitoring to verify system effectiveness.	New Liners in WAP, EAP and NSP isolate CCR material in pond and mitigate on-going source of CCR constituents to groundwater. Migration of CCR constituents in groundwater controlled at pond boundaries by vertical barrier. Groundwater elevations upgradient of barrier controlled by groundwater extraction.	Liner construction is a common and effective source control technology. Vertical hydraulic barrier must be keyed into lower impermeable layer. Groundwater extraction and treatment is a common and effective hydraulic control technology. Treatment system operational reliability is key component of overall reliability.	Readily implementable with common construction techniques. Bench/pilot testing of treatment system required. Regulatory authorization for treated water discharge could be difficult to obtain.	Source controlled through pond liner systems. Control of CCR constituent migration downgradient of pond by vertical barrier. Vertical barrier does not address groundwater beneath pond.	Retrofit Implementation: 1-2 years per pond. Barrier and GW Ext/Treat Implementation: 5-8 years. Groundwater modelling required to assess remediation timeframe.	Regulatory authorization for treated water discharge required. Treatment system residuals (sludge, regenerate brine, etc.) require management.

LUMINANT

FIGURES

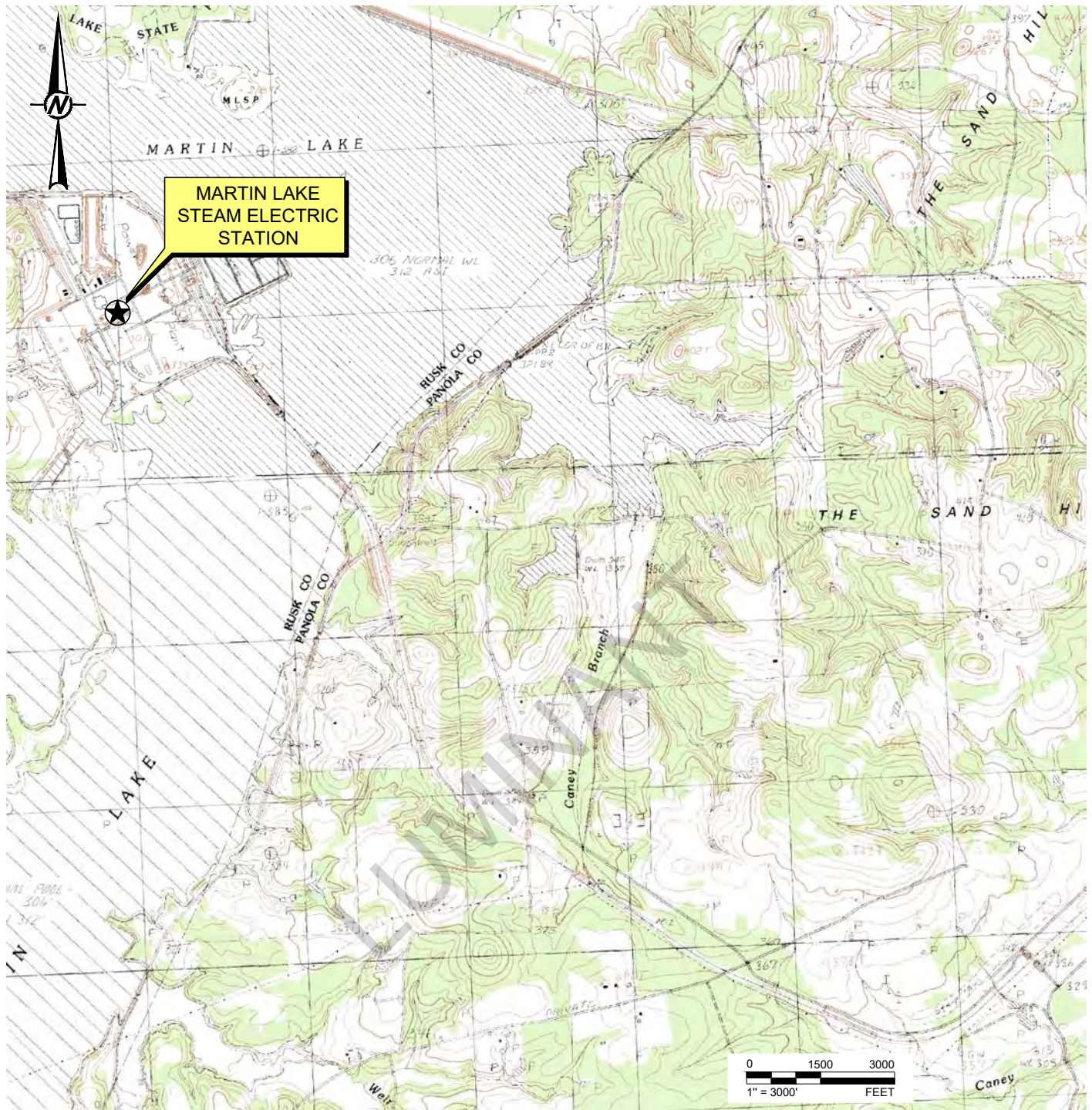

Last Edited By: adiamond Date: 2019-08-28 Time: 12:07:47 PM | Printed By: adiamond Date: 2019-08-28 Time: 12:09:57 PM
 Path: \\laxatama\data\Projects - Round Rock\19121403 - Luminant\Martin Lake Ash Pond Area | File Name: FIG 1 - Site Location Map.dwg

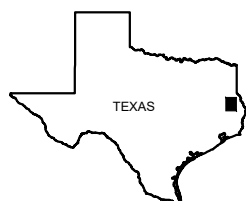

QUADRANGLE LOCATION

CLIENT
LUMINANT

PROJECT
**MARTIN LAKE STEAM ELECTRIC STATION
TATUM, TEXAS**

TITLE
SITE LOCATION MAP

CONSULTANT



YYYY-MM-DD	2019-08-28
DESIGNED	AJD
PREPARED	AJD
REVIEWED	WFV
APPROVED	WFV

REFERENCE(S)

BASE MAP TAKEN FROM TNRIS.GOV, TATUM, TX 7.5 MIN. USGS QUADRANGLE DATED 1983.

PROJECT NO.
19121403

REV.
0





FIGURE
1

IF THIS MEASUREMENT DOES NOT MATCH WHAT IS SHOWN, THE SHEET SIZE HAS BEEN MODIFIED FROM ANS/A





LEGEND

-  DOWNGRADIENT CCR MONITORING WELL
-  UPGRADIENT CCR MONITORING WELL
-  LAKE WATER/GROUNDWATER MIXING ZONE SAMPLE
-  MNA SOIL SAMPLE
-  CROSS SECTION LOCATION

CLIENT
LUMINANT

PROJECT
**MARTIN LAKE STEAM ELECTRIC STATION
TATUM, TEXAS**

TITLE
DETAILED SITE PLAN - ASH POND AREA

CONSULTANT



YYYY-MM-DD	2019-08-28
DESIGNED	AJD
PREPARED	AJD
REVIEWED	WVW
APPROVED	WVW

REFERENCE(S)

BASE MAP TAKEN FROM GOOGLE EARTH, IMAGERY DATED 4/6/17.

PROJECT NO.
19121403

REV.
0

FIGURE
2

Path: \\uswest\shared\proj\19121403 - Round Deck\19121403 - Luminant\Martin Lake Ash Pond Area | File Name: FIG.3-5 - Cross Sections.dwg | Last Edited By: adammond | Date: 2019-08-28 | Time: 2:30:44 PM | Printed By: adammond | Date: 2019-08-28 | Time: 2:52:58 PM

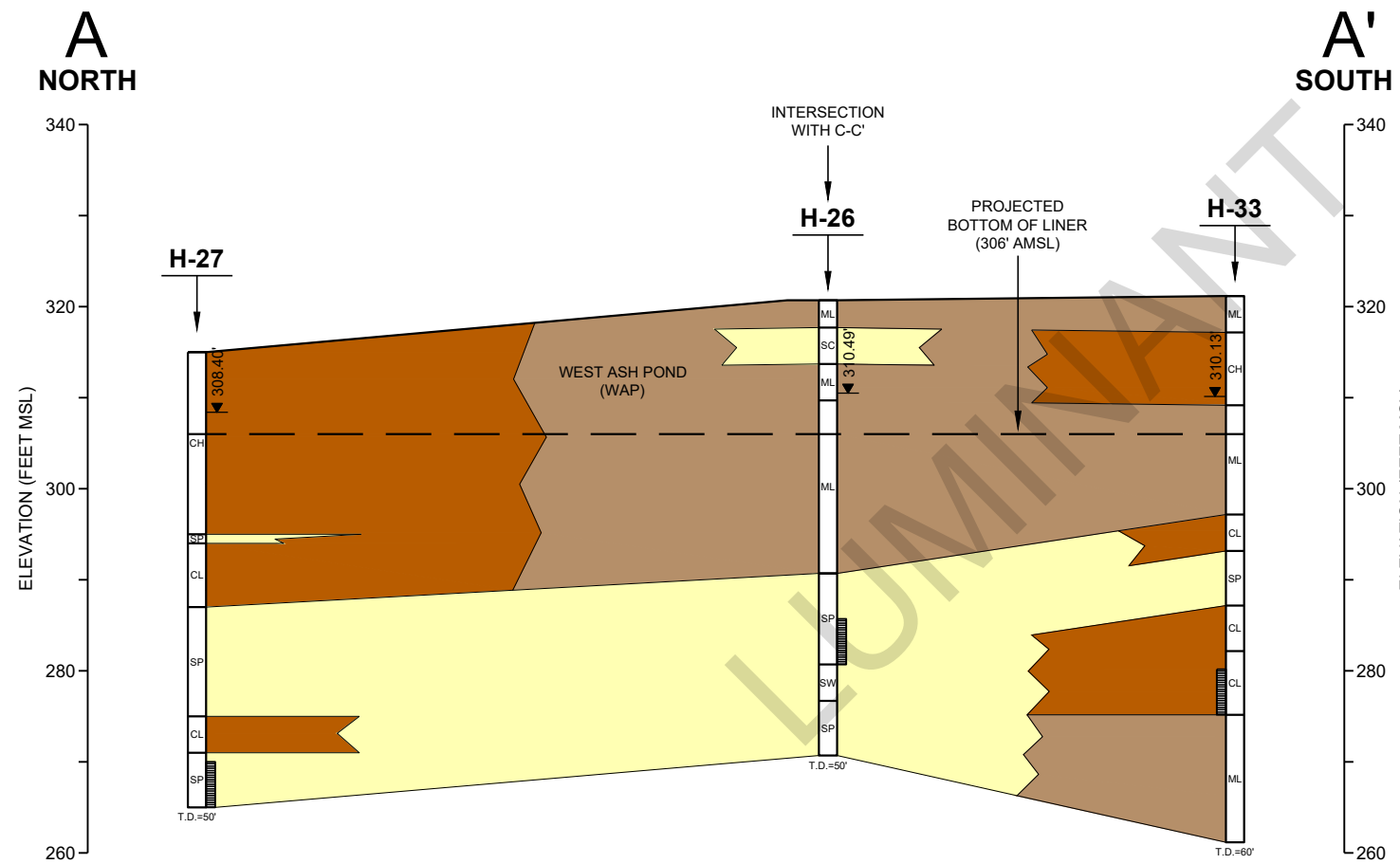

LEGEND

FILL	FILL
SAND	SAND
CLAY	CLAY
SILT	SILT

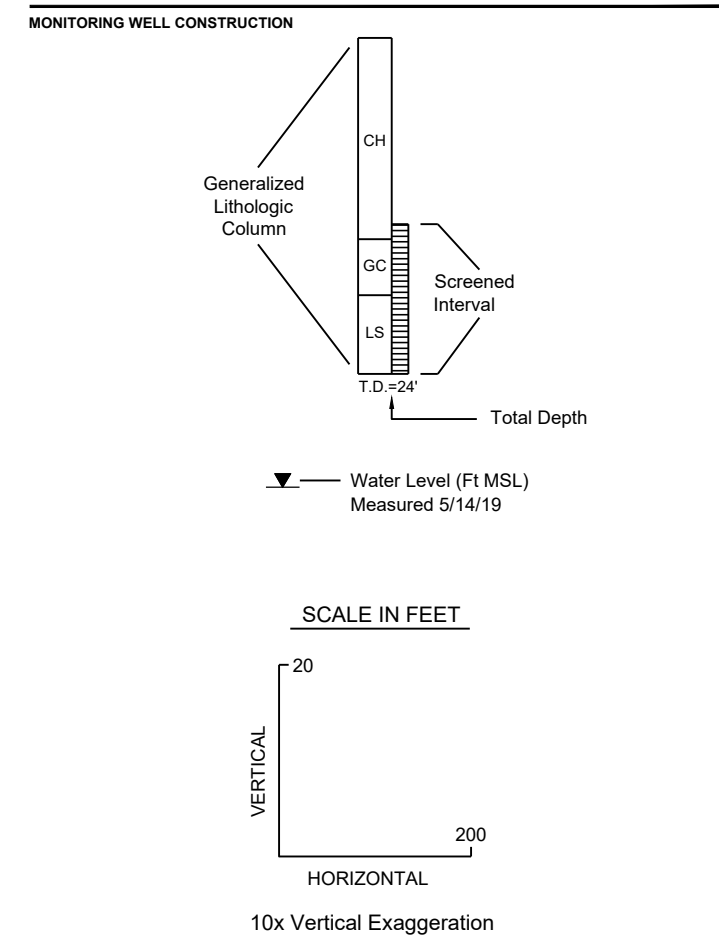

CLIENT	LUMINANT	
PROJECT	MARTIN LAKE STEAM ELECTRIC STATION TATUM, TEXAS	
TITLE	ASH POND AREA - GEOLOGIC CROSS SECTION A-A' WEST SIDE OF WEST ASH POND THROUGH PROCESS WATER POND	
CONSULTANT	YYYY-MM-DD	2019-08-28
	DESIGNED	AJD
	PREPARED	AJD
	REVIEWED	WFV
	APPROVED	WFV

IF THIS MEASUREMENT DOES NOT MATCH WHAT IS SHOWN, THE SHEET SIZE HAS BEEN MODIFIED FROM ANSI B

Path: \\uswest\external\proj\19121403 - Round Rock\19121403 - Luminant\Martin Lake Ash Pond Area | File Name: FIG 3-B - Cross Sections.dwg | Last Edited By: adiamond | Date: 2019-08-28 | Time: 2:30:44 PM | Printed By: adiamond | Date: 2019-08-28 | Time: 2:53:26 PM

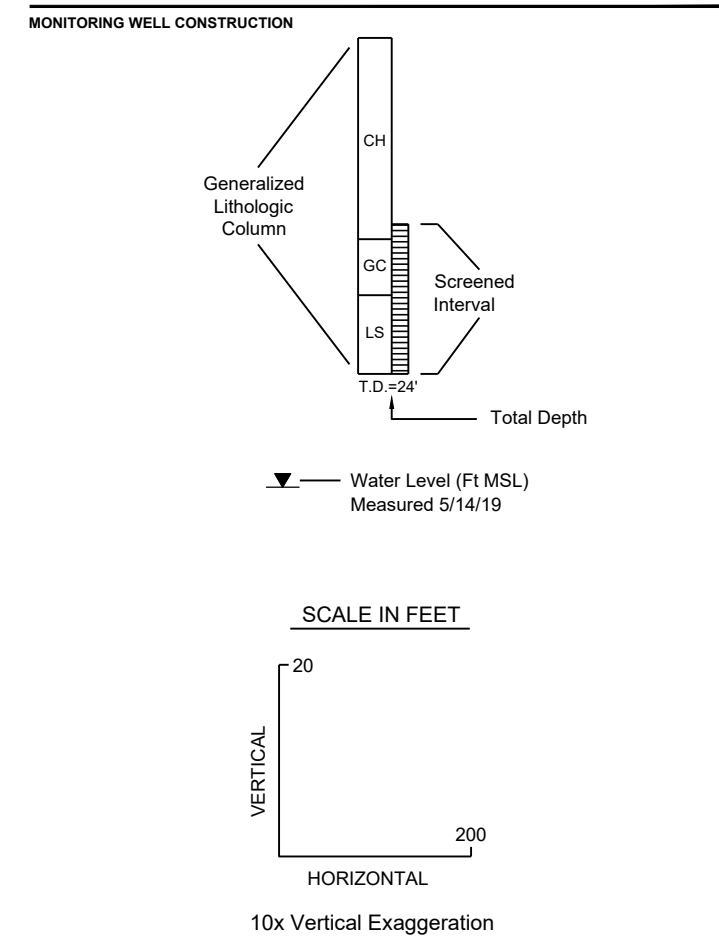
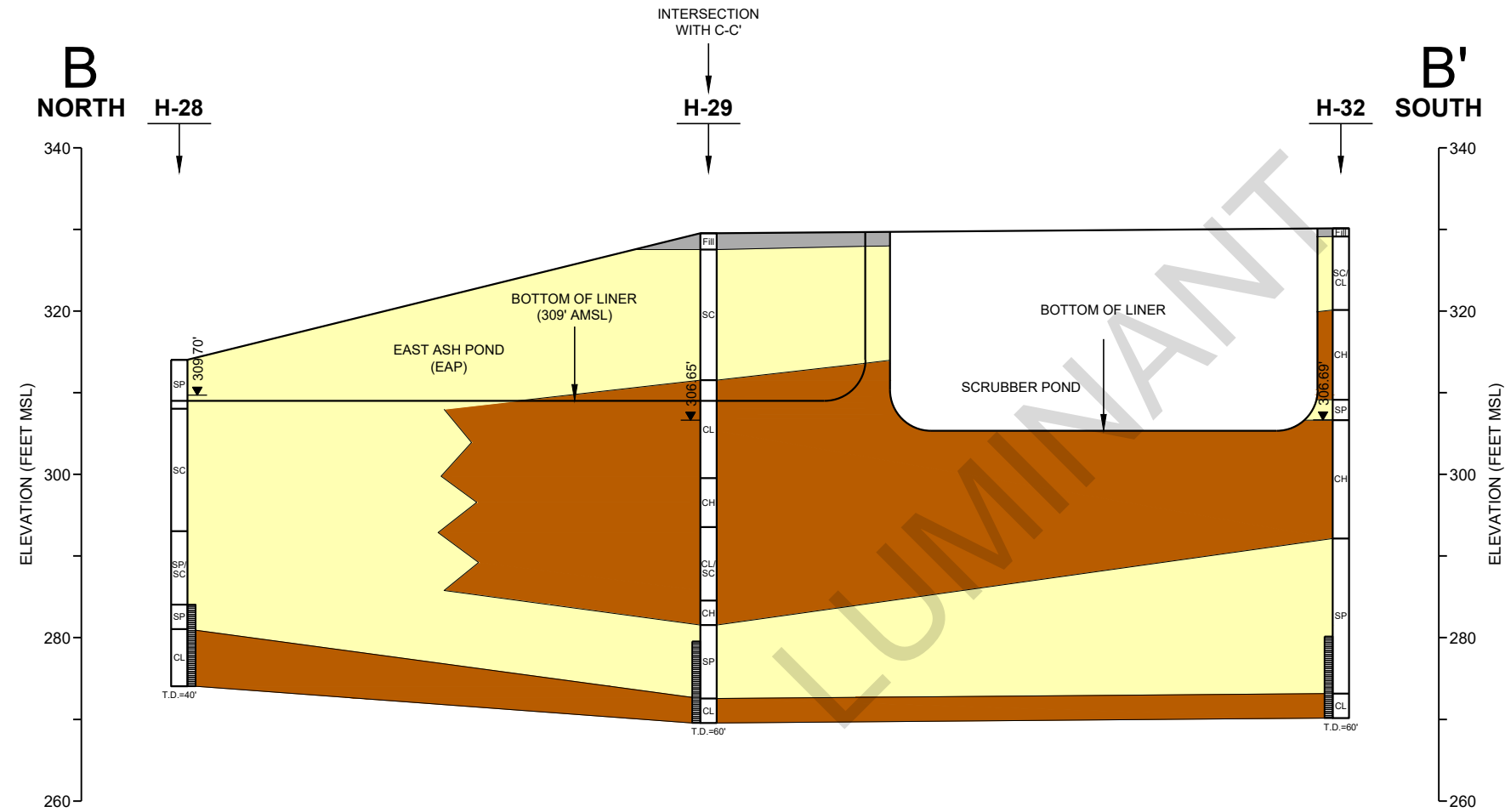

CLIENT
LUMINANT

PROJECT
MARTIN LAKE STEAM ELECTRIC STATION
TATUM, TEXAS

TITLE
**ASH POND AREA - GEOLOGIC CROSS SECTION B-B'
EAST SIDE OF ASH POND THROUGH SCRUBBER POND**

CONSULTANT	YYYY-MM-DD	2019-08-28
	DESIGNED	AJD
	PREPARED	AJD
	REVIEWED	WFV
	APPROVED	WFV

1 in. IF THIS MEASUREMENT DOES NOT MATCH WHAT IS SHOWN, THE SHEET SIZE HAS BEEN MODIFIED FROM ANSI B

Path: \\usmartincad\proj\19121403 - Round Rock\19121403 - Luminant\Martin Lake Ash Pond Area | File Name: FIG.3-5 - Cross Sections.dwg | Last Edited By: adiamond | Date: 2019-08-28 | Time: 2:54:02 PM

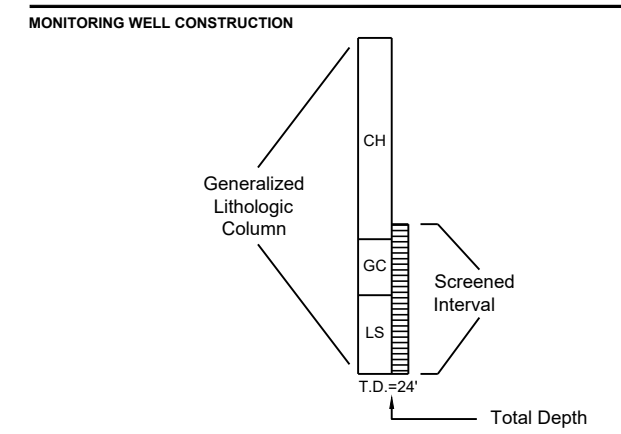
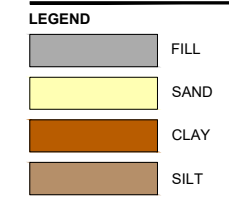
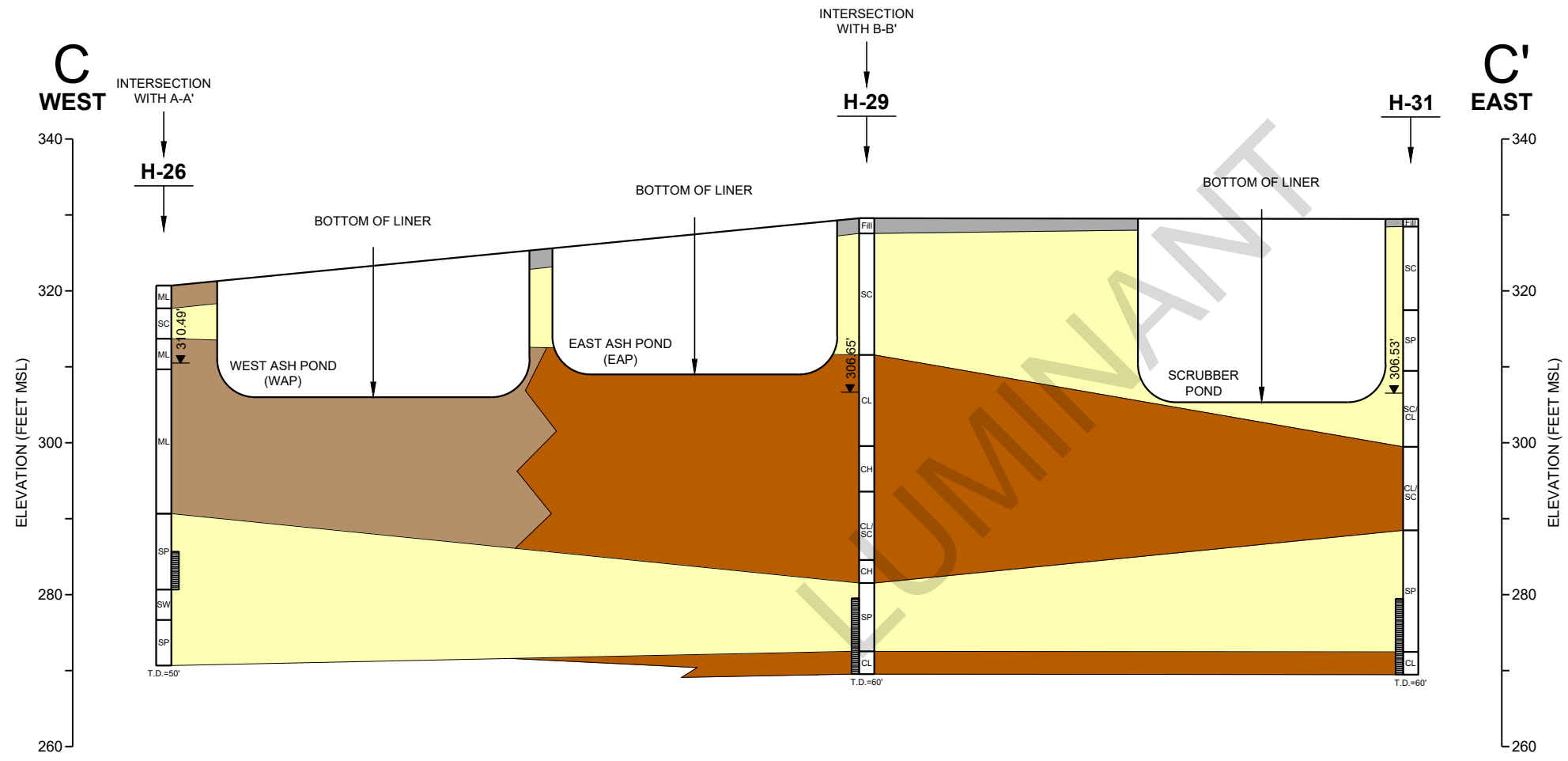

▼ Water Level (Ft MSL)
Measured 5/14/19

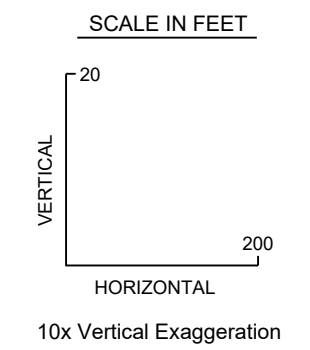

CLIENT
LUMINANT

PROJECT
**MARTIN LAKE STEAM ELECTRIC STATION
TATUM, TEXAS**

TITLE
**ASH POND AREA - GEOLOGIC CROSS SECTION C-C'
THROUGH WEST ASH POND AND EAST ASH POND**

CONSULTANT	YYYY-MM-DD	2019-08-28
DESIGNED	AJD	
PREPARED	AJD	
REVIEWED	WFV	
APPROVED	WFV	

PROJECT NO.
19121403

REV.
0



FIGURE
5

1 in. IF THIS MEASUREMENT DOES NOT MATCH WHAT IS SHOWN, THE SHEET SIZE HAS BEEN MODIFIED FROM ANSI B



Last Edited By: pmbhld Date: 2019-06-26 Time: 12:45:32 PM | Printed By: P:\McBride Date: 2019-07-15 Time: 11:20:29 AM
 Path: \\laxatana.golder.com\data\Projects - Round Rock\19122449 - Luminant\Martin Lake | File Name: FIG 3 - POT Surface Map-Ash Pond Area (May 2019).dwg

LEGEND

-  DOWNGRADIENT CCR MONITORING WELL
-  UPGRADIENT CCR MONITORING WELL
- (308.70)** GROUNDWATER POTENTIOMETRIC SURFACE (FT MSL)
- 308 —** GROUNDWATER POTENTIOMETRIC SURFACE CONTOUR (C.I. = 1 FT)

CLIENT
LUMINANT

PROJECT
**MARTIN LAKE STEAM ELECTRIC STATION
TATUM, TEXAS**

TITLE
**ASH POND AREA
POTENTIOMETRIC SURFACE MAP
MAY 14, 2019**

CONSULTANT	YYYY-MM-DD	2019-06-24
DESIGNED		AJD
PREPARED		AJD
REVIEWED		WVW
APPROVED		WVW









REFERENCE(S)
BASE MAP TAKEN FROM GOOGLE EARTH, IMAGERY DATED 4/6/17.

PROJECT NO. 19122449 REV. 0 FIGURE 6

IF THIS MEASUREMENT DOES NOT MATCH WHAT IS SHOWN, THE SHEET SIZE HAS BEEN MODIFIED FROM: ANSI A



LEGEND

-  DOWNGRADIENT CCR MONITORING WELL
-  UPGRADIENT CCR MONITORING WELL
-  LAKE WATER/GROUNDWATER MIXING ZONE SAMPLE
-  MNA SOIL SAMPLE
-  SSLs FOR ONE OR MORE APPENDIX IV CONSTITUENTS IN DOWNGRADIENT WELLS BASED ON INITIAL STATISTICAL EVALUATION
-  SSLs FOR ONE OR MORE APPENDIX IV CONSTITUENTS IN DOWNGRADIENT WELLS BASED ON UPDATED STATISTICAL EVALUATION

REFERENCE(S)

BASE MAP TAKEN FROM GOOGLE EARTH, IMAGERY DATED 4/6/17.

CLIENT
LUMINANT

PROJECT
**MARTIN LAKE STEAM ELECTRIC STATION
TATUM, TEXAS**

TITLE
**ASH POND AREA
EXTENT OF APPENDIX IV CONSTITUENTS
DETECTED AT SSLs ABOVE GWPSs**

CONSULTANT	YYYY-MM-DD	2019-08-29
DESIGNED		AJD
PREPARED		AJD
REVIEWED		WVW
APPROVED		WVW



PROJECT NO.
19121403

REV.
0

FIGURE
7

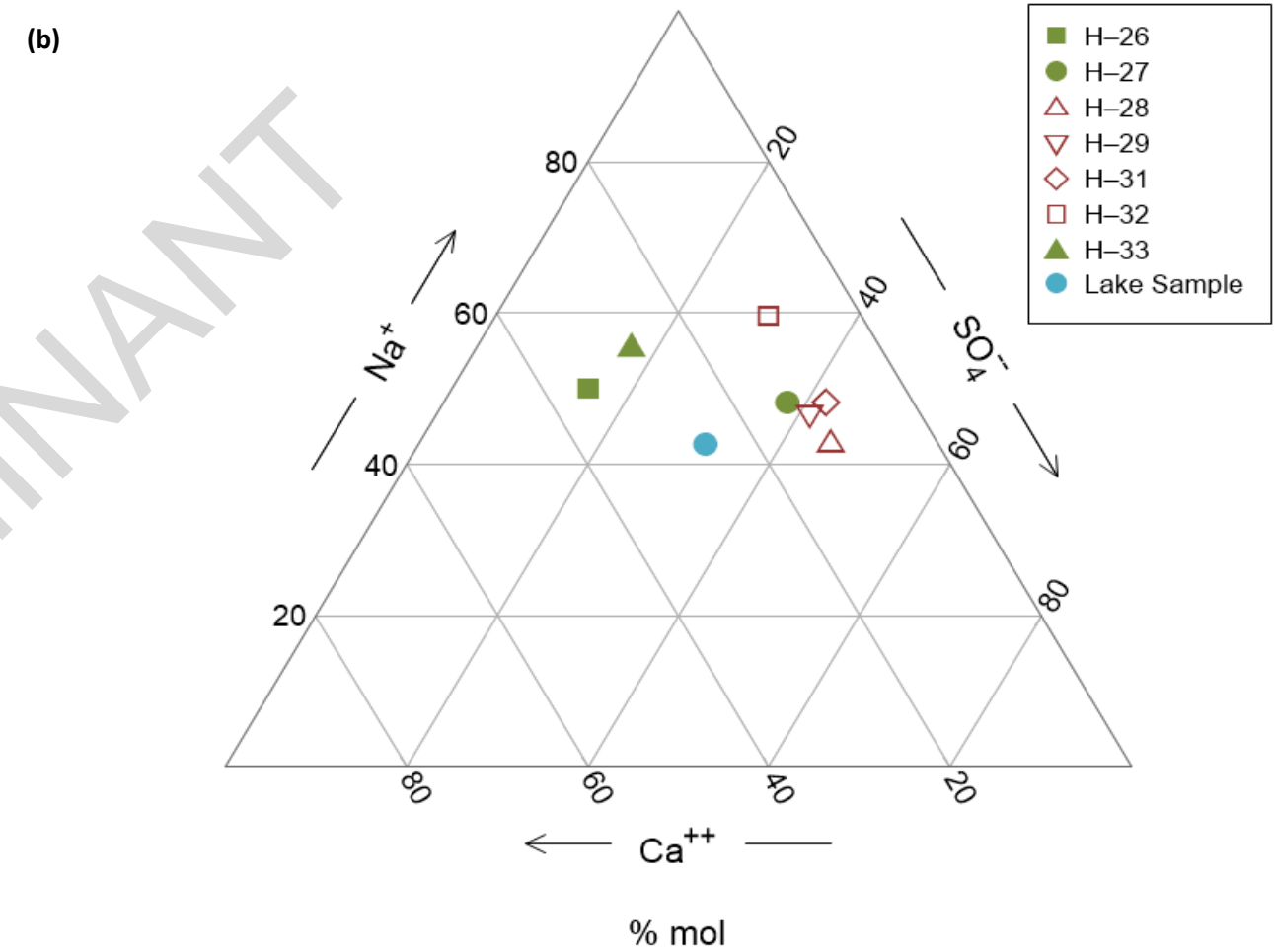
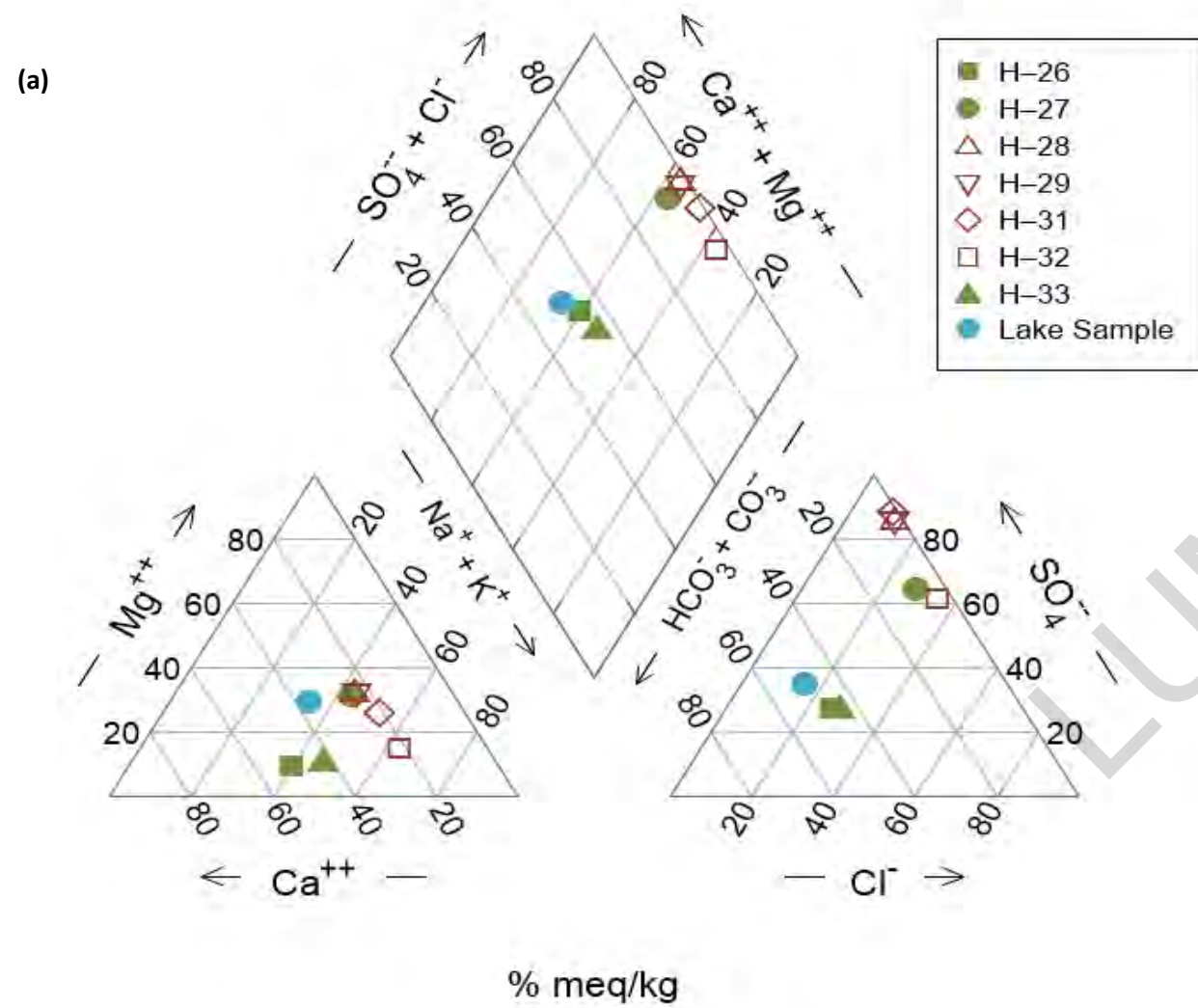

CLIENT
LUMINANT
MARTIN LAKE SES
ASH POND AREA
CONSULTANT

PROJECT
ASSESSMENT OF CORRECTIVE MEASURES
GEOCHEMICAL ASSESSMENT



TITLE
MAJOR GROUNDWATER CHEMISTRY (A)
AND SELECT RELATIVE ION ABUNDANCE (B)
IN GROUNDWATER AT MONITORING WELLS

PROJECT NO.
19122434

PHASE
01

REV.
A

FIGURE
8a-b

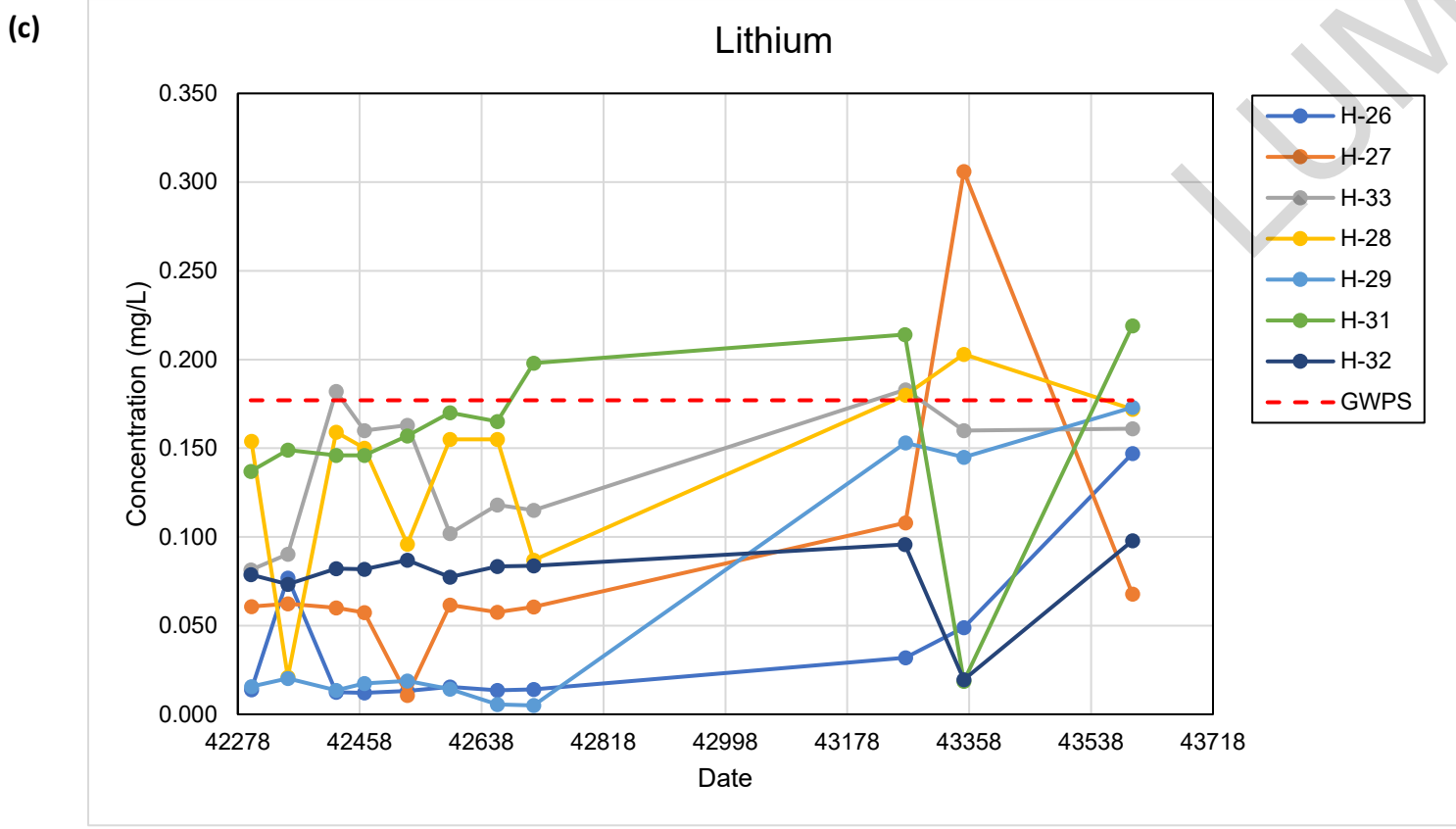
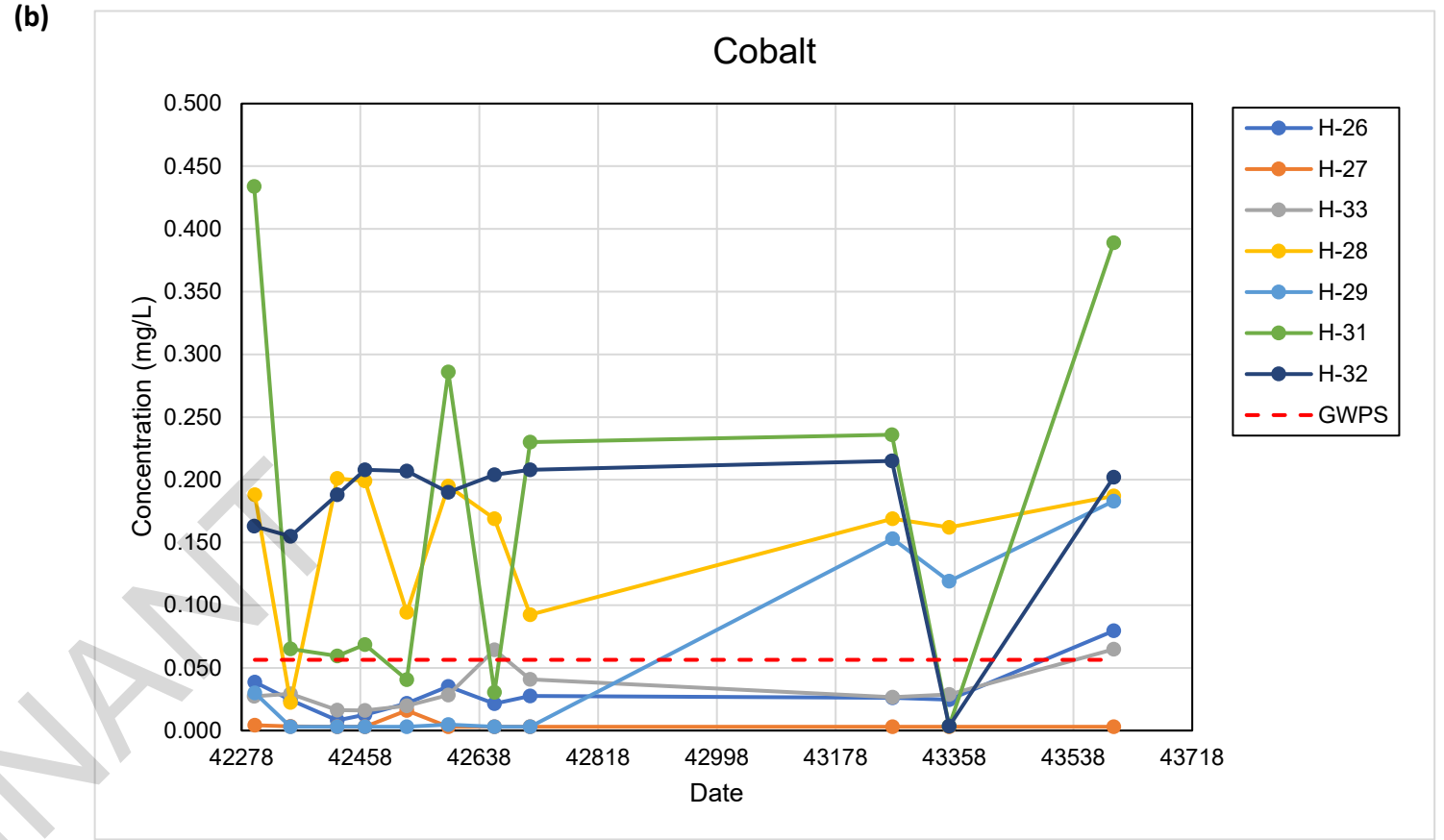
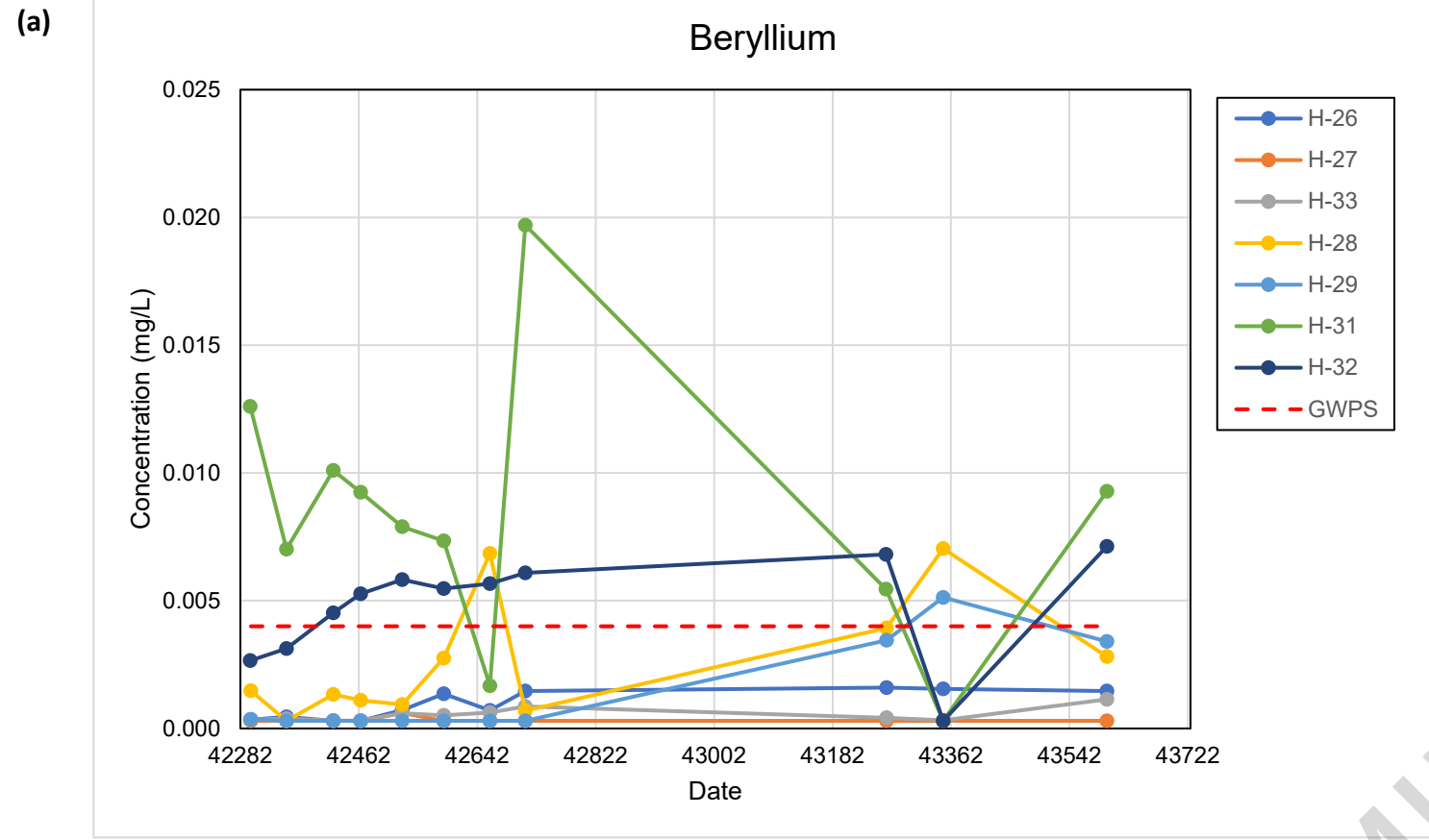

CLIENT
LUMINANT
MARTIN LAKE SES
ASH POND AREA
CONSULTANT



PROJECT
ASSESSMENT OF CORRECTIVE MEASURES
GEOCHEMICAL ASSESSMENT

TITLE
HISTORICAL TRENDS OF BERYLLIUM (A), COBALT (B), AND
LITHIUM (C), IN GROUNDWATER AT MONITORING WELLS

PROJECT NO.
19122434

PHASE
01

REV.
A

FIGURE
9a-c

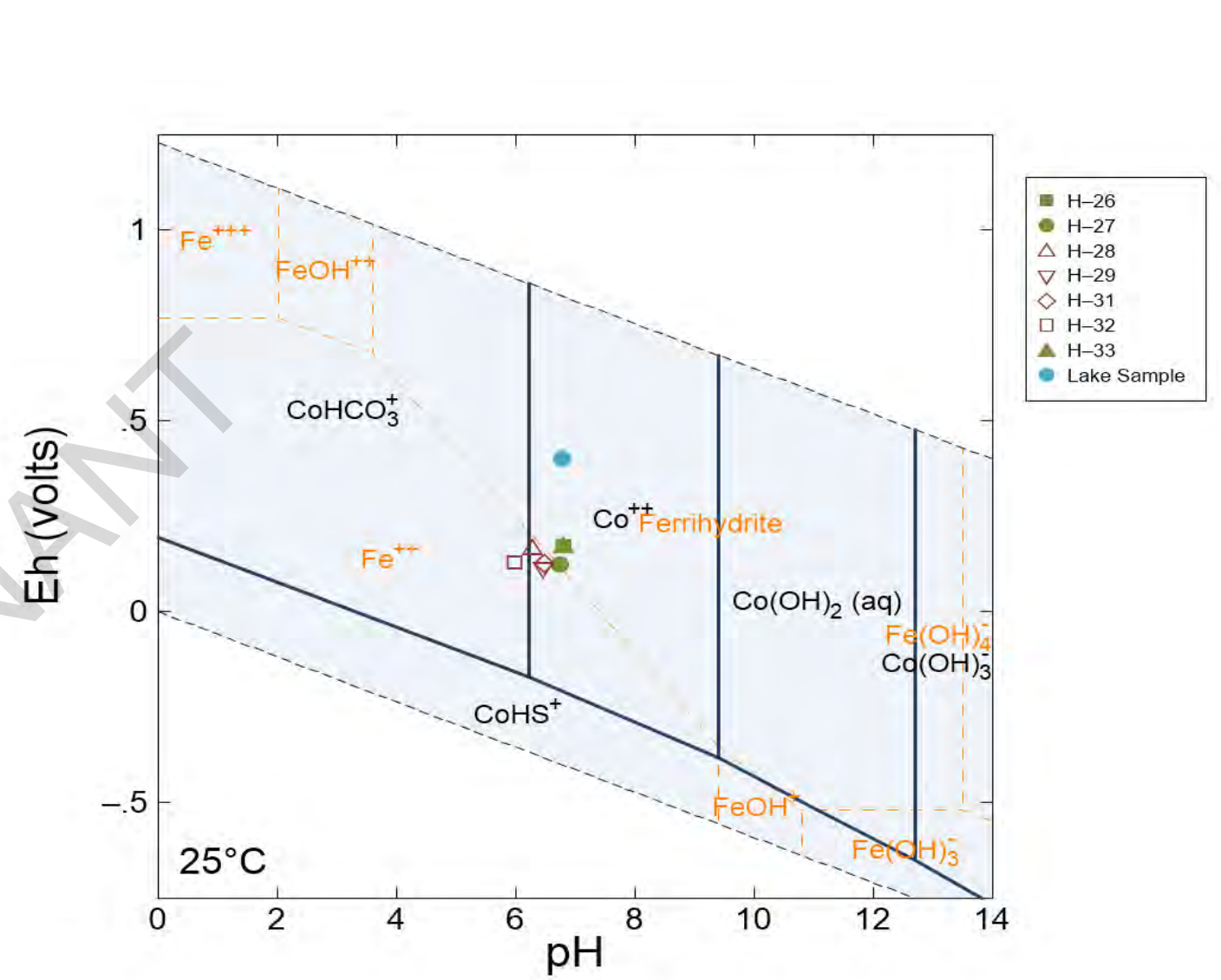
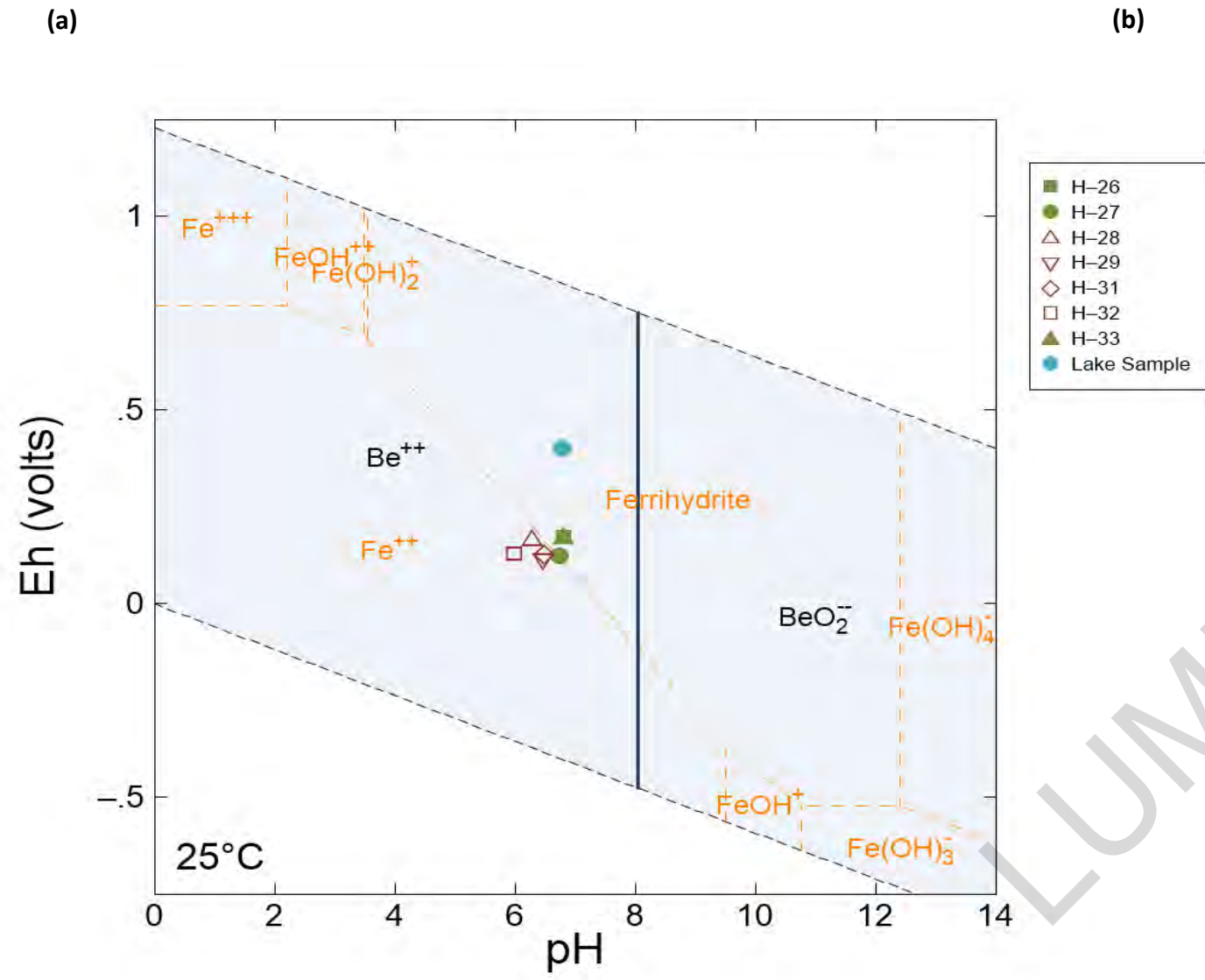

CLIENT
LUMINANT
MARTIN LAKE SES
ASH POND AREA
CONSULTANT



PROJECT
ASSESSMENT OF CORRECTIVE MEASURES
GEOCHEMICAL ASSESSMENT

TITLE
SPECIATION OF BERYLLIUM (A), AND
COBALT (B), IN GROUNDWATER

PROJECT NO.
164817101

PHASE
01

REV.
A

FIGURE
10a-b

LUMINANT

APPENDIX A

BORING LOGS

Luminant

Log of Boring: H-26

Martin Lake Steam Electric Station Tatum, TX	Completion Date:	9/14/2015	Drilling Method:	Sonic
	Drilling Company:	Walker-Hill Environmental	Borehole Diameter (in.):	6.5
PBW Project No. 5164B	Driller:	Timmy Beach	Total Depth (ft):	50
	Driller's License:	5814M	TOC Elevation (ft. AMSL):	323.701
	Logged By:	Ryan Francis	Northing:	1042229019.685
	Sampling Method:	4"x10' Core barrel	Easting:	2907068.36

Depth (ft)	Well Materials	Recovery (ft/ft)	USCS	Lithologic Description
0				(0 - 3) Silty CLAY, dark brown, dry, soft to firm, weak cementation, low plasticity
4		10.0/10.0	CL	(3 - 7) Sandy CLAY, red/orange with gray clay ribbons, dry, soft to firm, weak cementation, medium plasticity, minor rounded pebbles
8			SM	(7 - 11) Silty SAND, gray, dry, soft, weak cementation, subrounded, sharp contact
12		10.0/10.0		
16			SC	(11 - 30) Clayey silty SAND, tan with red and gray ribbons, moist to wet, soft, weak cementation, medium plasticity
20		10.0/10.0		
24			SP	(30 - 40) SAND, tan and orange, fine grained, higher clay content (31'-34'), wet, very soft to soft, low to medium plasticity
28				
32		10.0/10.0	SW	(40 - 44) SAND, red, wet, soft to firm, moderate cementation, heavy iron content, iron concretions ("rocky" texture)
36				
40		10.0/10.0	SP	(44 - 50) SAND, red and gray, wet, soft, fine grained, subrounded, gradual color change to dark brown/black (47'-50'), moisture content decreases with depth, hard sand (48'-50')
44				
48				
52				

PBW

Pastor, Behling & Wheeler, LLC
 2201 Double Creek Dr., Suite 4004
 Round Rock, TX 78664
 Tel (512) 671-3434 Fax (512) 671-3446

Notes:

1. This log should not be used separately from the report to which it is attached.

Well Materials

(0-35) Casing, 2" Sch 40 FJT PVC
 (35-40) Screen, 2" Sch 40 FJT PVC, 0.010" slot

Annular Materials

(0'-31') Grout
 (31'-33') Bentonite pellets
 (33'-40') 20/40 sand

Luminant

Log of Boring: H-27

Martin Lake Steam Electric Station Tatum, TX	Completion Date:	9/15/2015	Drilling Method:	Sonic
	Drilling Company:	Walker-Hill Environmental	Borehole Diameter (in.):	6.5
PBW Project No. 5164B	Driller:	Timmy Beach	Total Depth (ft):	50
	Driller's License:	5814M	TOC Elevation (ft. AMSL):	330.423
	Logged By:	Ryan Francis	Northing:	1038229615.42
	Sampling Method:	4"x10' Core barrel	Easting:	2906850.991

Depth (ft)	Well Materials	Recovery (ft/ft)	USCS	Lithologic Description
0				
4		10.0/10.0		
8			CL	(0 - 20) CLAY, orange and brown mottling, minor black streaking, blocky, moist, soft to hard, low to high plasticity, dry and variable sand content (5'-7'), wet at 20'
12		10.0/10.0		
16				
20			SP	(20 - 21) SAND, gray, moist, soft, subrounded, sharp contact
24		10.0/10.0	CL	(21 - 28) CLAY, gray and orange, blocky, moist, firm to hard, moderate cementation, low plasticity
28				
32		10.0/10.0	SP	(28 - 40) SAND, light gray to tan/orange, moist to wet, soft, none to low plasticity, minor clay content decreasing with depth
36				
40			CL	(40 - 44) Sandy CLAY, orange and gray, moist, firm, low to medium plasticity, sharp contact, very hard and little to no sand at 43'
44		10.0/10.0		
48			SC	(44 - 50) Clayey SAND, orange and gray, wet, soft, low plasticity, fine grained, decreasing clay content with depth, sharp contact, color change to brown at 48'
52				

PBW

Pastor, Behling & Wheeler, LLC
 2201 Double Creek Dr., Suite 4004
 Round Rock, TX 78664
 Tel (512) 671-3434 Fax (512) 671-3446

Notes:

1. This log should not be used separately from the report to which it is attached.

Well Materials

(0-45) Casing, 2" Sch 40 FJT PVC
 (45-50) Screen, 2" Sch 40 FJT PVC, 0.010" slot



Annular Materials

(0'-41') Grout
 (41'-43') Bentonite pellets
 (43'-50') 20/40 sand

Luminant

Log of Boring: H-28

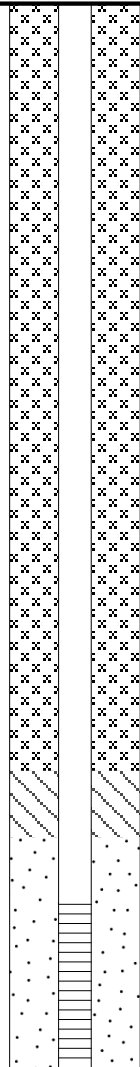
Martin Lake Steam Electric Station Tatum, TX	Completion Date:	9/15/2015	Drilling Method:	Sonic
	Drilling Company:	Walker-Hill Environmental	Borehole Diameter (in.):	6.5
PBW Project No. 5164B	Driller:	Timmy Beach	Total Depth (ft):	40
	Driller's License:	5814M	TOC Elevation (ft. AMSL):	316.821
	Logged By:	Ryan Francis	Northing:	1030230033.689
	Sampling Method:	4"x10' Core barrel	Easting:	2907668.815

Depth (ft)	Well Materials	Recovery (ft/ft)	USCS	Lithologic Description
0		10.0/10.0		(0 - 6) Soil with SAND, tan, dry, firm, moderate cementation, hard packed, abundant organics
2				10.0/10.0
4		10.0/10.0	SP	
6				
8	10.0/10.0		(33 - 40) Silty CLAY, dark gray, moderate sand, dry, hard, weak cementation	
10				
12				
14				
16				
18				
20				
22				
24				
26				
28				
30				
32				
34				
36				
38				
40				

PBW

Pastor, Behling & Wheeler, LLC
 2201 Double Creek Dr., Suite 4004
 Round Rock, TX 78664
 Tel (512) 671-3434 Fax (512) 671-3446

Notes:

1. This log should not be used separately from the report to which it is attached.

Well Materials

(0-27) Casing, 2" Sch 40 FJT PVC
 (27-32) Screen, 2" Sch 40 FJT PVC, 0.010" slot

Annular Materials

(0'-23') Grout
 (23'-25') Bentonite pellets
 (25'-32') 20/40 sand

Luminant

Log of Boring: H-29

Martin Lake Steam Electric Station Tatum, TX	Completion Date:	9/23/2015	Drilling Method:	Sonic
	Drilling Company:	Walker-Hill Environmental	Borehole Diameter (in.):	6.5
PBW Project No. 5164B	Driller:	Timmy Beach	Total Depth (ft):	60
	Driller's License:	5814M	TOC Elevation (ft. AMSL):	329.255
	Logged By:	Ryan Francis	Northing:	1026229427.784
	Sampling Method:	4"x10' Core barrel	Easting:	2907899.511

Depth (ft)	Well Materials	Recovery (ft/ft)	USCS	Lithologic Description
0			FILL	(0 - 2) Hard rock road bed, dry
4		10.0/10.0	SC	(2 - 18) Clayey SAND, orange and gray mottling, very fine grained, dry to moist, firm, weak cementation, low to medium plasticity, increasing clay content with depth
8		10.0/10.0	SC	
12		10.0/10.0	CL	(18 - 30) CLAY, orange, moist, firm, low to medium plasticity, very little sand or silt, black striping at 22', increasing sand content with depth (28'-30')
16		10.0/10.0	CL	
20		10.0/10.0	GH	(30 - 36) CLAY, orange, moist, soft, friable, high plasticity, minor silt
24		10.0/10.0	GH	
28		10.0/10.0	CL/SC	(36 - 45) Sandy CLAY/Clayey SAND, orange/gray/red mottling, friable, wet, soft to firm, low to medium plasticity, increasing clay content with depth
32		10.0/10.0	CL/SC	
36		10.0/10.0	CH	(45 - 48) CLAY with sand, orange and gray mottling, wet, soft, high plasticity
40		10.0/10.0	CH	
44		10.0/10.0	SP	(48 - 57) SAND, gray, wet, soft, no to low plasticity, some black roots/ organics, interspersed clay lenses
48		10.0/10.0	SP	
52		10.0/10.0	CL	(57 - 60) Silty CLAY, gray/brown, dry, hard, weak cementation, sharp contact
56		10.0/10.0	CL	
60				

PBW

Pastor, Behling & Wheeler, LLC
 2201 Double Creek Dr., Suite 4004
 Round Rock, TX 78664
 Tel (512) 671-3434 Fax (512) 671-3446

Notes:

1. This log should not be used separately from the report to which it is attached.

Well Materials

(0-52) Casing, 2" Sch 40 FJT PVC
 (52-57) Screen, 2" Sch 40 FJT PVC, 0.010" slot

Annular Materials

(0'-48') Grout
 (48'-50') Bentonite pellets
 (50'-57') 20/40 sand

Luminant

Log of Boring: H-31

Martin Lake Steam Electric Station Tatum, TX	Completion Date:	9/24/2015	Drilling Method:	Sonic
	Drilling Company:	Walker-Hill Environmental	Borehole Diameter (in.):	6.5
PBW Project No. 5164B	Driller:	Timmy Beach	Total Depth (ft):	60
	Driller's License:	5814M	TOC Elevation (ft. AMSL):	329.258
	Logged By:	Ryan Francis	Northing:	1035229262.289
	Sampling Method:	4"x10' Core barrel	Easting:	2908596.681

Depth (ft)	Well Materials	Recovery (ft/ft)	USCS	Lithologic Description
0			FILE	(0 - 1) Hard, packed gravel road bed, dry
4		10.0/10.0	SC	(1 - 12) Clayey SAND, orange, dry to moist, soft to firm, low plasticity, fine grained, increasing clay content with depth, gray clay ribbons at 10'
8				
12		5.0/10.0	SP	(12 - 20) SAND, orange with red and gray mottling, dry to moist, soft, none to low plasticity, weak cementation, fine grained, very little clay
16				
20		10.0/10.0	CL	(20 - 30) Sandy CLAY, orange, dry to moist, firm, crumbly, color variation with depth, low plasticity, some gray sand lenses, very fine grained, color change to gray at 29'
24				
28		10.0/10.0	CL/SC	(30 - 41) Sandy CLAY/ Clayey SAND, gray and tan, moist, soft, fine grained, low plasticity, variations in clay content and firmness with depth, moisture content changes to wet at 35'
32				
36		10.0/10.0	SP	(41 - 57) SAND, orange/tan, wet, very soft, fine grained, subrounded, increasing red color with depth starting at 52', hard iron concretion layer with some black staining at 55'
40				
44		10.0/10.0		
48				
52		10.0/10.0		
56				
60			CL	(57 - 60) Sandy CLAY, gray, dry to moist, hard, fine grained, weak cementation, low plasticity

PBW

Pastor, Behling & Wheeler, LLC
2201 Double Creek Dr., Suite 4004
Round Rock, TX 78664
Tel (512) 671-3434 Fax (512) 671-3446

Notes:

1. This log should not be used separately from the report to which it is attached.

Well Materials

(0-42) Casing, 2" Sch 40 FJT PVC
(42-52) Screen, 2" Sch 40 FJT PVC, 0.010" slot

Annular Materials

(0'-38') Grout
(38'-40') Bentonite pellets
(40'-52') 20/40 sand

Luminant

Log of Boring: H-32

Martin Lake Steam Electric Station Tatum, TX	Completion Date:	9/24/2015	Drilling Method:	Sonic
	Drilling Company:	Walker-Hill Environmental	Borehole Diameter (in.):	6.5
PBW Project No. 5164B	Driller:	Timmy Beach	Total Depth (ft):	60
	Driller's License:	5814M	TOC Elevation (ft. AMSL):	329.854
	Logged By:	Ryan Francis	Northing:	1034228728.295
	Sampling Method:	4"x10' Core barrel	Easting:	2908232.588

Depth (ft)	Well Materials	Recovery (ft/ft)	USCS	Lithologic Description
0			FILE	(0 - 1) Hard, packed gravel road bed, dry
4		10.0/10.0	SC/CL	(1 - 10) Sandy CLAY/Clayey SAND, orange/tan, dry, firm, fine grained, low plasticity, weak cementation
8				
12		10.0/10.0	CH	(10 - 21) CLAY with minor silt/sand, orange with some black streaks, moist, firm, high plasticity, gradual contact
16				
20			SP	(21 - 23.5) SAND, gray, dry, soft to firm, friable, fine grained
24		10.0/10.0		
28			CH	(23.5 - 38) CLAY, orange/tan/gray, moist, soft to firm, high plasticity, minor sand at 30', tan and gray with orange stripes (30'-38'), sharp contact
32		10.0/10.0		
36				
40			SP	(38 - 57) SAND, orange/tan, moist to wet, very soft to soft, fine grained, subrounded, minor clay, low plasticity, no clay content at 42', gradual coarsening of sand grains (48'-55'), some gray streakings at 49', color change to reddish brown at 52'
44		10.0/10.0		
48				
52				
56		10.0/10.0		
60			CL	(57 - 60) Sandy CLAY, dark red and brown, wet, soft, low plasticity, layer of dark red concretions at 57', weak cementation

PBW

Pastor, Behling & Wheeler, LLC
2201 Double Creek Dr., Suite 4004
Round Rock, TX 78664
Tel (512) 671-3434 Fax (512) 671-3446

Notes:

1. This log should not be used separately from the report to which it is attached.

Well Materials

(0-42) Casing, 2" Sch 40 FJT PVC
(42-52) Screen, 2" Sch 40 FJT PVC, 0.010" slot

Annular Materials

(0'-38') Grout
(38'-40') Bentonite pellets
(40'-52') 20/40 sand

Luminant

Log of Boring: H-33

Martin Lake Steam Electric Station Tatum, TX	Completion Date:	9/14/2015	Drilling Method:	Sonic
	Drilling Company:	Walker-Hill Environmental	Borehole Diameter (in.):	6.5
PBW Project No. 5164B	Driller:	Timmy Beach	Total Depth (ft):	60
	Driller's License:	5814M	TOC Elevation (ft. AMSL):	323.845
	Logged By:	Ryan Francis	Northing:	1041228608.597
	Sampling Method:	4"x10' Core barrel	Easting:	2907267.556

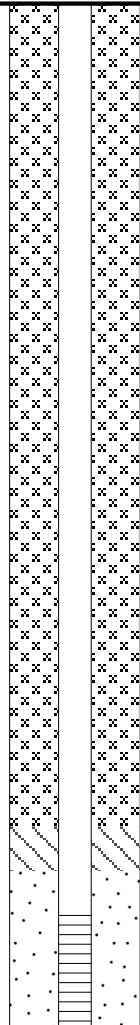
Depth (ft)	Well Materials	Recovery (ft/ft)	USCS	Lithologic Description
0		10.0/10.0	CL	(0 - 4) Silty CLAY, minor sand, red and orange with gray ribbons, dry, soft to firm, low to medium plasticity
4			GH	(4 - 12) CLAY, red with gray concretions, moist, soft to firm, high plasticity, gradual contact
8		10.0/10.0	ML	(12 - 24) Sandy SILT, gray and red, dry, soft, weak cementation, sharp contact, red and gray clay lens at 19'
12				
16		10.0/10.0	CL	(24 - 28) CLAY, red, moist to wet, soft to firm, high plasticity, pebbles present
20				
24		10.0/10.0	SP	(28 - 34) SAND, gray, wet, soft to firm, minor clay, low to medium plasticity, subrounded, increasing clay content with depth, sharp contact
28				
32		10.0/10.0	CL	(34 - 39) CLAY, orange and gray mottling, dry, very hard, moderate cementation, low plasticity
36				
40	10.0/10.0	CL	(39 - 46) Sandy CLAY, orange and gray, moist to wet, firm, medium plasticity, weak cementation, increasing sand content with depth	
44				
48	10.0/10.0	ML	(46 - 60) Sandy SILT, dark gray, dry, hard	
52				
56				
60				

PBW

Pastor, Behling & Wheeler, LLC
 2201 Double Creek Dr., Suite 4004
 Round Rock, TX 78664
 Tel (512) 671-3434 Fax (512) 671-3446

Notes:

1. This log should not be used separately from the report to which it is attached.

Well Materials

(0-41) Casing, 2" Sch 40 FJT PVC
 (41-46) Screen, 2" Sch 40 FJT PVC, 0.010" slot

Annular Materials

(0'-37') Grout
 (37'-39') Bentonite pellets
 (39'-46') 20/40 sand

Luminant

Log of Boring: AP-2019-1

Big Brown Steam Electric Station Franklin, TX	Completion Date:	6/3/2019	Drilling Method:	Sonic
	Drilling Company:	Walker-Hill Environmental	Borehole Diameter (in.):	6
Golder Project No. 19122434E	Driller:	Rodney Labrosse	Total Depth (ft):	40
	Driller's License:	60059	TOC Elevation (ft. AMSL):	
	Logged By:	Kelsey Worley	Northing:	3570888
	Sampling Method:	4"x10' Core barrel	Easting:	352661.3

Depth (ft)	Recovery (ft/ft)	USCS	Lithologic Description
0			(0 - 1) Silty CLAY, brown, roots present, low plasticity, slightly moist
5	10.0/10.0	CL	(1 - 8) Silty CLAY, brown to orange, moist, moderate plasticity, soft to hard
10		SC	(8 - 12.5) Clayey SAND, orange and brown, moist, soft, clay content increases with depth, moderate plasticity
15	10.0/10.0	CH	(12.5 - 22) CLAY, gray to light brown, blocky, moist, firm to stiff, low plasticity
25	10.0/10.0	SW	(22 - 34) SAND, light brown to gray and orange, moist, very fine to fine grained, subrounded, soft to firm, iron staining 22'-23.5', color change to light gray and light brown at 24', saturated at 30'
35	10.0/10.0	SC	(34 - 40) Clayey SAND, gray and tan, becomes gray to dark gray at 35.5', stiff, moist, variations in clay content and firmness with depth
40			

LUMINANT



Notes:
1. This log should not be used separately from the report to which it is attached.

Luminant

Log of Boring: AP-2019-2

Big Brown Steam Electric Station Franklin, TX	Completion Date:	6/3/2019	Drilling Method:	Sonic
	Drilling Company:	Walker-Hill Environmental	Borehole Diameter (in.):	6
Golder Project No. 19122434E	Driller:	Rodney Labrosse	Total Depth (ft):	40
	Driller's License:	60059	TOC Elevation (ft. AMSL):	
	Logged By:	Kelsey Worley	Northing:	3570800
	Sampling Method:	4"x10' Core barrel	Easting:	352739.4

Depth (ft)	Recovery (ft/ft)	USCS	Lithologic Description
0			
5	10.0/10.0	CL	(0 - 6) Silty CLAY, brown to gray, soft to firm, damp, low plasticity
10			(6 - 11) Sandy CLAY, red and orange with gray, clay ribbons, damp, soft to firm, weak cementation, moderate plasticity
15	10.0/10.0	SC	(11 - 20) Clayey Silty SAND, tan with red and gray, clay ribbons, moist, firm, weak cementation, moderate plasticity
20		SW	(20 - 22) SAND, light brown, moist to wet, fine grained, subrounded, soft
25	10.0/10.0	SC	(22 - 34) Clayey SAND, gray and tan, becomes gray to dark, gray at 26', stiff, moist, brown clay ribbons from 27'-29.5'
30			
35	10.0/10.0	SW	(34 - 40) SAND, gray, very fine to fine grained, wet, subrounded, soft to firm, saturated 35'-38', black organics at 38.8'-40.0'
40			

Notes:

1. This log should not be used separately from the report to which it is attached.

Luminant

Log of Boring: AP-2019-3

Big Brown Steam Electric Station Franklin, TX	Completion Date:	6/3/2019	Drilling Method:	Sonic
	Drilling Company:	Walker-Hill Environmental	Borehole Diameter (in.):	6
Golder Project No. 19122434E	Driller:	Rodney Labrosse	Total Depth (ft):	30
	Driller's License:	60059	TOC Elevation (ft. AMSL):	
	Logged By:	Kelsey Worley	Northing:	352739.4
	Sampling Method:	4"x10' Core barrel	Easting:	3570800

Depth (ft)	Recovery (ft/ft)	USCS	Lithologic Description
0		SM	(0 - 6) Silty SAND, light brown, firm, moderate cementation, roots present 0'-1.5'
5	10.0/10.0		
10		SC	(6 - 11) Clayey SAND, orange to brown, moist, soft to firm, no plasticity, weak cementation, gray sand lense, fine grained, at 11', fine to very fine grained
15	10.0/10.0		
20		SP	(11 - 18) Clayey SAND, wet, gray and tan to orange, soft to firm, sand content increases with depth
25	10.0/10.0		
30		CL	(18 - 25) SAND, orange and gray, saturated, fine grained, soft, no cementation
			(25 - 30) Silty CLAY, dark gray, dry, hard, moderate sand content, weak cementation

APPENDIX B

**LABORATORY ANALYTICAL
REPORTS**

LUMINANT



June 14, 2019

Will Vienne
Golder
2201 Double Creek Dr #4004
Round Rock, Texas 78664
TEL: (512) 671-3434
FAX (512) 671-3446
RE: Luminant-MLSES Ash Ponds

Order No.: 1905168

Dear Will Vienne:

DHL Analytical, Inc. received 7 sample(s) on 5/15/2019 for the analyses presented in the following report.

There were no problems with the analyses and all data met requirements of NELAP except where noted in the Case Narrative. All non-NELAP methods will be identified accordingly in the case narrative and all estimated uncertainties of test results are within method or EPA specifications.

If you have any questions regarding these tests results, please feel free to call. Thank you for using DHL Analytical.

Sincerely,

A handwritten signature in black ink, appearing to read 'John DuPont', written over a large, light grey watermark that says 'LUMINANT' diagonally across the page.

John DuPont
General Manager

This report was performed under the accreditation of the State of Texas Laboratory Certification Number: T104704211-19-24



Table of Contents

Miscellaneous Documents	3
CaseNarrative 1905168	8
WorkOrderSampleSummary 1905168	10
PrepDatesReport 1905168	11
AnalyticalDatesReport 1905168	14
Analytical Report 1905168	18
AnalyticalQCSummaryReport 1905168	32
Subcontract Report 1905168	57

LUMINANT



2300 Double Creek Dr. ■ Round Rock, TX 78664
 Phone (512) 388-8222 ■ FAX (512) 388-8229
 Web: www.dhlanalytical.com
 E-Mail: login@dhlanalytical.com



No 86479
CHAIN-OF-CUSTODY

CLIENT: GOLDER
 ADDRESS: 2201 DOUBLE CREEK DR, ROUND ROCK, TX 78664
 PHONE: 512-671-3434 FAX/E-MAIL: 512-671-3446
 DATA REPORTED TO: WILL VIENNE
 ADDITIONAL REPORT COPIES TO:

DATE: 5-14-19 PAGE 1 OF 1
 PO #: _____ DHL WORK ORDER #: 1905168
 PROJECT LOCATION OR NAME: LUMINANT- MLSES ASH PONDS
 CLIENT PROJECT #: 19122262-C COLLECTOR: J. BRAYTON

Authorize 5% surcharge for TRRP Report?
 Yes No

S=SOIL P=PAINT
 W=WATER SL=SLUDGE
 A=AIR O=OTHER
 L=LIQUID SO=SOLID
 SE=SEDIMENT

PRESERVATION
 HCl HNO₃ H₂SO₄ NaOH ICE UNPRESERVED

Field Sample I.D.	DHL Lab #	Date	Time	Matrix	Container Type	# of Containers	HCl	HNO ₃	H ₂ SO ₄	NaOH	ICE	UNPRESERVED
H-31	01	5-14-19	0740	W		7					X	
H-32	02		0825	W		7					X	
H-27	03		0940	W		7					X	
H-29	04		1125	W		7					X	
H-28	05		1250	W		7					X	
H-26	06		1425	W		7					X	
H-33	07		1530	W		7					X	

ANALYSES
 BTEX MTBE I/METHOD 80211
 TPH 1005 TPH 1006 HOLD 1006
 GRO I/METHOD 80191 DRO I/METHOD 81051
 VOC 8260 VOC 624 VOC 8260/5935
 SVOC 8270 PAH 8270 HOLD PAH SVOC 6285
 8270 PEST 625 PEST/PCB 608 PCB
 8270 O-P PEST 8082 PCB 8270 PCB
 8321 HERB T PHOS AMMONIA
 METALS 6020 METALS 2008 DISS. METALS
 PH HEX CHROM ALKALINITY COD
 CHLORIDE ANIONS
 TCLP-SVOC VOC PEST HERB
 RCL FLASHPOINT RCRA 800 TX-11 PB
 TDS TSS % MOISTURE CYANIDE
APPENDIX III & IV
ALK. NO. 1-104 Na OH
FEDEX & FEDEX

FIELD NOTES

RELINQUISHED BY: (Signature) [Signature] DATE/TIME 5-14-19
 RECEIVED BY: (Signature) Fed Ex
 RELINQUISHED BY: (Signature) [Signature] DATE/TIME 5/15/19 0943
 RECEIVED BY: (Signature) [Signature]
 RELINQUISHED BY: (Signature) _____ DATE/TIME _____
 RECEIVED BY: (Signature) _____

TURN AROUND TIME
 RUSH CALL FIRST
 1 DAY CALL FIRST
 2 DAY
 NORMAL
 OTHER

LABORATORY USE ONLY:
 RECEIVING TEMP: 45/30.2 THERM #: 78
 CUSTODY SEALS: BROKEN INTACT NOT USED
 CARRIER: LONE STAR FEDEX UPS OTHER
 COURIER DELIVERY
 HAND DELIVERED

DHL DISPOSAL @ \$5.00 each Return

Eric Lau

From: John DuPont
Sent: Tuesday, May 28, 2019 11:35 AM
To: Eric Lau
Subject: FW: CCR Analysis

Appendix III Parameters:

Metals (Ca and B)
Anions (Cl, F, and SO4)
TDS

Appendix IV Parameters:

Metals (As, Ba, Be, Cd, Co, Cr, Hg, Li, Mo, Pb, Sb, Se, and Tl)
Ra-226
Ra-228

From: Vienne, Will [mailto:William_Vienne@golder.com]
Sent: Tuesday, April 09, 2019 12:48 PM
To: John DuPont <dupont@dhlanalytical.com>
Subject: CCR Analysis

LUMINANT

ORIGIN ID:GGGA (512) 671-3434
J. BRAYTON
GOLDER
2201 DOUBLE CREEK DR
ROUND ROCK, TX 78664
UNITED STATES US

SHIP DATE: 14MAY19
ACTWT: 48.70 LB
CAD: 006894186/SSFE2002
DIMS: 23x13x13 IN
BILL THIRD PARTY

Part 138297 0182/138297/138297/138297/138297

TO

DHL
2300 DOUBLE CREEK DR
ROUND ROCK TX 78664

(512) 388-8222

REF:

DEPT:

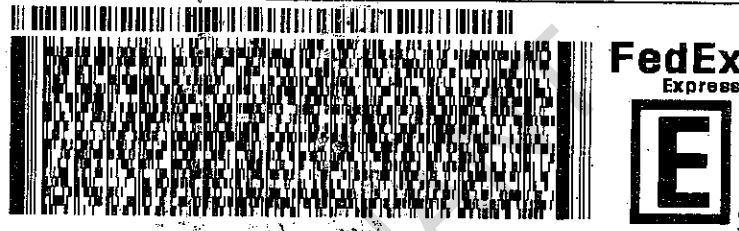

4 of 4

WED - 15 MAY 10:30A
PRIORITY OVERNIGHT

MPS# 7872 5506 5879

Mstr# 7872 5506 5848

0201

A8 BSMA

78664
TX-US AUS



ORIGIN ID:GGGA (512) 671-3434
J. BRAYTON
GOLDER
2201 DOUBLE CREEK DR
ROUND ROCK, TX 78664
UNITED STATES US

SHIP DATE: 14MAY19
ACTWGT: 50.90 LB
CAD: 006994166/56FE2002
DIMS: 23x14x14 IN
BILL THIRD PARTY

Part #: 136297/ARF42906/1595-10/19

TO

DHL
2300 DOUBLE CREEK DR

ROUND ROCK TX 78664

(512) 386-6222
INU:
PO:

REF:

DEPT:

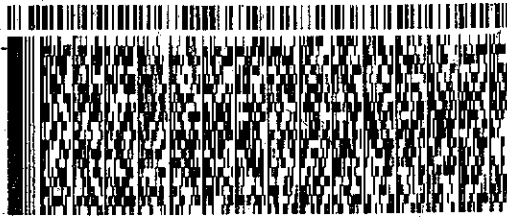

FedEx
Express



an10201081010101

2 of 4

MPS# 7872 5506 5857
0263

Matr# 7872 5506 5846

0201

WED - 15 MAY 10:30A
PRIORITY OVERNIGHT

A8 BSMA

78664
TX-US AUS

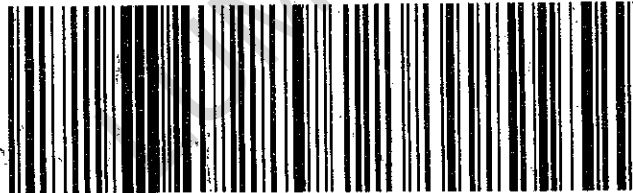

Sample Receipt Checklist

Client Name Golder

Date Received: 5/15/2019

Work Order Number 1905168

Received by EL

Checklist completed by: [Signature]
Signature

5/15/2019
Date

Reviewed by [Initials]
Initials

5/15/2019
Date

Carrier name FedEx 1day

- Shipping container/cooler in good condition? Yes No Not Present
- Custody seals intact on shipping container/cooler? Yes No Not Present
- Custody seals intact on sample bottles? Yes No Not Present
- Chain of custody present? Yes No
- Chain of custody signed when relinquished and received? Yes No
- Chain of custody agrees with sample labels? Yes No
- Samples in proper container/bottle? Yes No
- Sample containers intact? Yes No
- Sufficient sample volume for indicated test? Yes No
- All samples received within holding time? Yes No
- Container/Temp Blank temperature in compliance? Yes No 4.5 °C
- Water - VOA vials have zero headspace? Yes No No VOA vials submitted
- Water - pH<2 acceptable upon receipt? Yes No NA LOT # 11837
- Adjusted? no Checked by EL
- Water - pH>9 (S) or pH>10 (CN) acceptable upon receipt? Yes No NA LOT #
- Adjusted? _____ Checked by _____

Any No response must be detailed in the comments section below.

Client contacted _____ Date contacted: _____ Person contacted _____

Contacted by: _____ Regarding: _____

Comments: _____

Corrective Action _____

CLIENT: Golder
Project: Luminant-MLSES Ash Ponds
Lab Order: 1905168

CASE NARRATIVE

Samples were analyzed using the methods outlined in the following references:

Method SW6020A - Metals Analysis
Method SW7470A - Mercury Analysis
Method E300 - Anions Analysis
Method M2320 B - Alkalinity Analysis
Method M3500-Fe D - Ferrous Iron Analysis (this parameter is not NELAP certified)
Method M3500-Fe D - Ferric Iron (calculation) (this calculation is not NELAP certified).
Method M4500-P E - Orthophosphate Analysis
Method M2540C - TDS Analysis
Sub-contract - Radium-228 and Radium-226 analyses by methods E904 and SM 7500 Ra B M.
Analyzed at Pace Analytical.

LOG IN

The samples were received and log-in performed on 5/15/19. A total of 7 samples were received. The samples arrived in good condition and were properly packaged.

METALS ANALYSIS

For Metals analysis performed on 5/20/19 and 5/21/19 the matrix spike and matrix spike duplicate recoveries were out of control limits for a total of four analytes. These are flagged accordingly in the QC summary report. The sample selected for the matrix spike and matrix spike duplicate was not from this work order. The LCS was within control limits for these analytes. No further corrective actions were taken.

For Metals analysis performed on 5/20/19 LCVL6-190520 was slightly above control limits for Sodium. This is flagged accordingly. The associated CCV6-190520 was within control limits for this analyte. No further corrective actions were taken.

ANIONS ANALYSIS

For Anions analysis performed on 5/15/19 (batch 90908) the matrix spike and matrix spike duplicate recoveries (1905167-02 MS/MSD) were out of control limits for Chloride and Sulfate. This was due to matrix effect. These are flagged accordingly in the QC summary report. The sample selected for the matrix spike and matrix spike duplicate was not from this work order. The LCS was within control limits for these analytes. No further corrective actions were taken.

FERRIC IRON (CALCULATION)

CLIENT: Golder
Project: Luminant-MLSES Ash Ponds
Lab Order: 1905168

CASE NARRATIVE

For Ferric Iron calculation the Ferrous Iron result was slightly higher than the total Iron result for sample H-31. This is within the acceptable variation limits. No further corrective actions were taken.

LUMINANT

CLIENT: Golder
Project: Luminant-MLSES Ash Ponds
Lab Order: 1905168

Work Order Sample Summary

Lab Smp ID	Client Sample ID	Tag Number	Date Collected	Date Recved
1905168-01	H-31		05/14/19 07:40 AM	5/15/2019
1905168-02	H-32		05/14/19 08:25 AM	5/15/2019
1905168-03	H-27		05/14/19 09:40 AM	5/15/2019
1905168-04	H-29		05/14/19 11:25 AM	5/15/2019
1905168-05	H-28		05/14/19 12:30 PM	5/15/2019
1905168-06	H-26		05/14/19 02:25 PM	5/15/2019
1905168-07	H-33		05/14/19 03:30 PM	5/15/2019

LUMINANT

Lab Order: 1905168
Client: Golder
Project: Luminant-MLSES Ash Ponds

PREP DATES REPORT

Sample ID	Client Sample ID	Collection Date	Matrix	Test Number	Test Name	Prep Date	Batch ID
1905168-01A	H-31	05/14/19 07:40 AM	Aqueous	M3500-Fe	Ferrous Iron Prep Water	05/20/19 02:56 PM	91002
	H-31	05/14/19 07:40 AM	Aqueous	M3500-Fe	Ferrous Iron Prep Water	05/20/19 02:56 PM	91002
1905168-01B	H-31	05/14/19 07:40 AM	Aqueous	SW3005A	Aq Prep Metals : ICP-MS	05/17/19 08:40 AM	90959
	H-31	05/14/19 07:40 AM	Aqueous	SW3005A	Aq Prep Metals : ICP-MS	05/17/19 08:40 AM	90959
	H-31	05/14/19 07:40 AM	Aqueous	SW3005A	Aq Prep Metals : ICP-MS	05/17/19 08:40 AM	90959
	H-31	05/14/19 07:40 AM	Aqueous	SW7470A	Mercury Aq Prep	05/21/19 09:56 AM	91017
	H-31	05/14/19 07:40 AM	Aqueous	SW7470A	Mercury Aq Prep	05/21/19 09:56 AM	91017
1905168-01C	H-31	05/14/19 07:40 AM	Aqueous	M2320 B	Alkalinity Preparation	05/16/19 10:12 AM	90940
	H-31	05/14/19 07:40 AM	Aqueous	E300	Anion Preparation	05/15/19 09:07 AM	90908
	H-31	05/14/19 07:40 AM	Aqueous	E300	Anion Preparation	05/15/19 09:07 AM	90908
	H-31	05/14/19 07:40 AM	Aqueous	E300	Anion Preparation	05/16/19 09:16 AM	90935
	H-31	05/14/19 07:40 AM	Aqueous	M4500-P E	Orthophosphate Prep	05/15/19 12:12 PM	90921
	H-31	05/14/19 07:40 AM	Aqueous	M2540C	TDS Preparation	05/16/19 03:23 PM	90953
1905168-02A	H-32	05/14/19 08:25 AM	Aqueous	M3500-Fe	Ferrous Iron Prep Water	05/20/19 02:56 PM	91002
	H-32	05/14/19 08:25 AM	Aqueous	M3500-Fe	Ferrous Iron Prep Water	05/20/19 02:56 PM	91002
1905168-02B	H-32	05/14/19 08:25 AM	Aqueous	SW3005A	Aq Prep Metals : ICP-MS	05/17/19 08:40 AM	90959
	H-32	05/14/19 08:25 AM	Aqueous	SW3005A	Aq Prep Metals : ICP-MS	05/17/19 08:40 AM	90959
	H-32	05/14/19 08:25 AM	Aqueous	SW3005A	Aq Prep Metals : ICP-MS	05/17/19 08:40 AM	90959
	H-32	05/14/19 08:25 AM	Aqueous	SW7470A	Mercury Aq Prep	05/21/19 09:56 AM	91017
1905168-02C	H-32	05/14/19 08:25 AM	Aqueous	M2320 B	Alkalinity Preparation	05/16/19 10:12 AM	90940
	H-32	05/14/19 08:25 AM	Aqueous	E300	Anion Preparation	05/15/19 09:07 AM	90908
	H-32	05/14/19 08:25 AM	Aqueous	E300	Anion Preparation	05/15/19 09:07 AM	90908
	H-32	05/14/19 08:25 AM	Aqueous	M4500-P E	Orthophosphate Prep	05/15/19 12:12 PM	90921
	H-32	05/14/19 08:25 AM	Aqueous	M2540C	TDS Preparation	05/16/19 03:23 PM	90953
1905168-03A	H-27	05/14/19 09:40 AM	Aqueous	M3500-Fe	Ferrous Iron Prep Water	05/20/19 02:56 PM	91002
1905168-03B	H-27	05/14/19 09:40 AM	Aqueous	SW3005A	Aq Prep Metals : ICP-MS	05/17/19 08:40 AM	90959
	H-27	05/14/19 09:40 AM	Aqueous	SW3005A	Aq Prep Metals : ICP-MS	05/17/19 08:40 AM	90959
	H-27	05/14/19 09:40 AM	Aqueous	SW3005A	Aq Prep Metals : ICP-MS	05/17/19 08:40 AM	90959

Lab Order: 1905168
 Client: Golder
 Project: Luminant-MLSES Ash Ponds

PREP DATES REPORT

Sample ID	Client Sample ID	Collection Date	Matrix	Test Number	Test Name	Prep Date	Batch ID
1905168-03B	H-27	05/14/19 09:40 AM	Aqueous	SW7470A	Mercury Aq Prep	05/21/19 09:56 AM	91017
1905168-03C	H-27	05/14/19 09:40 AM	Aqueous	M2320 B	Alkalinity Preparation	05/16/19 10:12 AM	90940
	H-27	05/14/19 09:40 AM	Aqueous	E300	Anion Preparation	05/15/19 09:07 AM	90908
	H-27	05/14/19 09:40 AM	Aqueous	E300	Anion Preparation	05/15/19 09:07 AM	90908
	H-27	05/14/19 09:40 AM	Aqueous	M4500-P E	Orthophosphate Prep	05/15/19 12:12 PM	90921
	H-27	05/14/19 09:40 AM	Aqueous	M2540C	TDS Preparation	05/16/19 03:23 PM	90953
1905168-04A	H-29	05/14/19 11:25 AM	Aqueous	M3500-Fe	Ferrous Iron Prep Water	05/20/19 02:56 PM	91002
1905168-04B	H-29	05/14/19 11:25 AM	Aqueous	SW3005A	Aq Prep Metals : ICP-MS	05/17/19 08:40 AM	90959
	H-29	05/14/19 11:25 AM	Aqueous	SW3005A	Aq Prep Metals : ICP-MS	05/17/19 08:40 AM	90959
	H-29	05/14/19 11:25 AM	Aqueous	SW3005A	Aq Prep Metals : ICP-MS	05/17/19 08:40 AM	90959
	H-29	05/14/19 11:25 AM	Aqueous	SW7470A	Mercury Aq Prep	05/21/19 09:56 AM	91017
1905168-04C	H-29	05/14/19 11:25 AM	Aqueous	M2320 B	Alkalinity Preparation	05/16/19 10:12 AM	90940
	H-29	05/14/19 11:25 AM	Aqueous	E300	Anion Preparation	05/15/19 09:07 AM	90908
	H-29	05/14/19 11:25 AM	Aqueous	E300	Anion Preparation	05/15/19 09:07 AM	90908
	H-29	05/14/19 11:25 AM	Aqueous	M4500-P E	Orthophosphate Prep	05/15/19 12:12 PM	90921
	H-29	05/14/19 11:25 AM	Aqueous	M2540C	TDS Preparation	05/16/19 03:23 PM	90953
1905168-05A	H-28	05/14/19 12:30 PM	Aqueous	M3500-Fe	Ferrous Iron Prep Water	05/20/19 02:56 PM	91002
1905168-05B	H-28	05/14/19 12:30 PM	Aqueous	SW3005A	Aq Prep Metals : ICP-MS	05/17/19 08:40 AM	90959
	H-28	05/14/19 12:30 PM	Aqueous	SW3005A	Aq Prep Metals : ICP-MS	05/17/19 08:40 AM	90959
	H-28	05/14/19 12:30 PM	Aqueous	SW3005A	Aq Prep Metals : ICP-MS	05/17/19 08:40 AM	90959
	H-28	05/14/19 12:30 PM	Aqueous	SW7470A	Mercury Aq Prep	05/21/19 09:56 AM	91017
1905168-05C	H-28	05/14/19 12:30 PM	Aqueous	M2320 B	Alkalinity Preparation	05/16/19 10:12 AM	90940
	H-28	05/14/19 12:30 PM	Aqueous	E300	Anion Preparation	05/15/19 09:07 AM	90908
	H-28	05/14/19 12:30 PM	Aqueous	E300	Anion Preparation	05/15/19 09:07 AM	90908
	H-28	05/14/19 12:30 PM	Aqueous	M4500-P E	Orthophosphate Prep	05/15/19 12:12 PM	90921
	H-28	05/14/19 12:30 PM	Aqueous	M2540C	TDS Preparation	05/16/19 03:23 PM	90953
1905168-06A	H-26	05/14/19 02:25 PM	Aqueous	M3500-Fe	Ferrous Iron Prep Water	05/20/19 02:56 PM	91002
1905168-06B	H-26	05/14/19 02:25 PM	Aqueous	SW3005A	Aq Prep Metals : ICP-MS	05/17/19 08:40 AM	90959

Lab Order: 1905168
Client: Golder
Project: Luminant-MLSES Ash Ponds

PREP DATES REPORT

Sample ID	Client Sample ID	Collection Date	Matrix	Test Number	Test Name	Prep Date	Batch ID
1905168-06B	H-26	05/14/19 02:25 PM	Aqueous	SW3005A	Aq Prep Metals : ICP-MS	05/17/19 08:40 AM	90959
	H-26	05/14/19 02:25 PM	Aqueous	SW3005A	Aq Prep Metals : ICP-MS	05/17/19 08:40 AM	90959
	H-26	05/14/19 02:25 PM	Aqueous	SW7470A	Mercury Aq Prep	05/21/19 09:56 AM	91017
1905168-06C	H-26	05/14/19 02:25 PM	Aqueous	M2320 B	Alkalinity Preparation	05/16/19 10:12 AM	90940
	H-26	05/14/19 02:25 PM	Aqueous	E300	Anion Preparation	05/15/19 09:07 AM	90908
	H-26	05/14/19 02:25 PM	Aqueous	E300	Anion Preparation	05/15/19 09:07 AM	90908
	H-26	05/14/19 02:25 PM	Aqueous	M4500-P E	Orthophosphate Prep	05/15/19 12:12 PM	90921
	H-26	05/14/19 02:25 PM	Aqueous	M2540C	TDS Preparation	05/16/19 03:23 PM	90953
1905168-07A	H-33	05/14/19 03:30 PM	Aqueous	M3500-Fe	Ferrous Iron Prep Water	05/20/19 02:56 PM	91002
1905168-07B	H-33	05/14/19 03:30 PM	Aqueous	SW3005A	Aq Prep Metals : ICP-MS	05/17/19 08:40 AM	90959
	H-33	05/14/19 03:30 PM	Aqueous	SW3005A	Aq Prep Metals : ICP-MS	05/17/19 08:40 AM	90959
	H-33	05/14/19 03:30 PM	Aqueous	SW3005A	Aq Prep Metals : ICP-MS	05/17/19 08:40 AM	90959
	H-33	05/14/19 03:30 PM	Aqueous	SW7470A	Mercury Aq Prep	05/21/19 09:56 AM	91017
1905168-07C	H-33	05/14/19 03:30 PM	Aqueous	M2320 B	Alkalinity Preparation	05/16/19 10:12 AM	90940
	H-33	05/14/19 03:30 PM	Aqueous	E300	Anion Preparation	05/15/19 09:07 AM	90908
	H-33	05/14/19 03:30 PM	Aqueous	E300	Anion Preparation	05/15/19 09:07 AM	90908
	H-33	05/14/19 03:30 PM	Aqueous	M4500-P E	Orthophosphate Prep	05/15/19 12:12 PM	90921
	H-33	05/14/19 03:30 PM	Aqueous	M2540C	TDS Preparation	05/16/19 03:23 PM	90953

Lab Order: 1905168
 Client: Golder
 Project: Luminant-MLSES Ash Ponds

ANALYTICAL DATES REPORT

Sample ID	Client Sample ID	Matrix	Test Number	Test Name	Batch ID	Dilution	Analysis Date	Run ID
1905168-01A	H-31	Aqueous	M3500-Fe D	Ferric Iron (Calculated)	91002	1	05/24/19	UV/VIS_2_190524A
	H-31	Aqueous	M3500-Fe D	Ferrous Iron	91002	1	05/20/19 03:55 PM	UV/VIS_2_190520A
	H-31	Aqueous	M3500-Fe D	Ferrous Iron	91002	100	05/20/19 04:11 PM	UV/VIS_2_190520A
1905168-01B	H-31	Aqueous	SW7470A	Mercury Total: Aqueous	91017	1	05/22/19 10:16 AM	CETAC2_HG_190522A
	H-31	Aqueous	SW7470A	Mercury Total: Aqueous	91017	5	05/22/19 11:21 AM	CETAC2_HG_190522A
	H-31	Aqueous	SW6020A	Trace Metals: ICP-MS - Water	90959	1	05/20/19 03:43 PM	ICP-MS4_190520B
	H-31	Aqueous	SW6020A	Trace Metals: ICP-MS - Water	90959	50	05/21/19 12:54 PM	ICP-MS5_190521A
	H-31	Aqueous	SW6020A	Trace Metals: ICP-MS - Water	90959	1	05/21/19 02:51 PM	ICP-MS5_190521A
1905168-01C	H-31	Aqueous	M2320 B	Alkalinity	90940	1	05/16/19 04:13 PM	TITRATOR_190516A
	H-31	Aqueous	E300	Anions by IC method - Water	90908	10	05/15/19 02:27 PM	IC2_190515A
	H-31	Aqueous	E300	Anions by IC method - Water	90908	1	05/15/19 05:55 PM	IC2_190515A
	H-31	Aqueous	E300	Anions by IC method - Water	90935	100	05/16/19 05:42 PM	IC4_190516A
	H-31	Aqueous	M4500-P E	Orthophosphate	90921	1	05/15/19 02:47 PM	UV/VIS_2_190515B
	H-31	Aqueous	M2540C	Total Dissolved Solids	90953	1	05/17/19 11:40 AM	WC_190517D
1905168-02A	H-32	Aqueous	M3500-Fe D	Ferric Iron (Calculated)	91002	1	05/24/19	UV/VIS_2_190524A
	H-32	Aqueous	M3500-Fe D	Ferrous Iron	91002	1	05/20/19 03:55 PM	UV/VIS_2_190520A
	H-32	Aqueous	M3500-Fe D	Ferrous Iron	91002	5	05/20/19 04:11 PM	UV/VIS_2_190520A
1905168-02B	H-32	Aqueous	SW7470A	Mercury Total: Aqueous	91017	1	05/22/19 10:27 AM	CETAC2_HG_190522A
	H-32	Aqueous	SW6020A	Trace Metals: ICP-MS - Water	90959	1	05/21/19 02:53 PM	ICP-MS5_190521A
	H-32	Aqueous	SW6020A	Trace Metals: ICP-MS - Water	90959	10	05/21/19 12:56 PM	ICP-MS5_190521A
	H-32	Aqueous	SW6020A	Trace Metals: ICP-MS - Water	90959	1	05/20/19 03:45 PM	ICP-MS4_190520B
1905168-02C	H-32	Aqueous	M2320 B	Alkalinity	90940	1	05/16/19 04:15 PM	TITRATOR_190516A
	H-32	Aqueous	E300	Anions by IC method - Water	90908	10	05/15/19 02:43 PM	IC2_190515A
	H-32	Aqueous	E300	Anions by IC method - Water	90908	1	05/15/19 06:11 PM	IC2_190515A
	H-32	Aqueous	M4500-P E	Orthophosphate	90921	1	05/15/19 12:49 PM	UV/VIS_2_190515B
	H-32	Aqueous	M2540C	Total Dissolved Solids	90953	1	05/17/19 11:40 AM	WC_190517D

Lab Order: 1905168
 Client: Golder
 Project: Luminant-MLSES Ash Ponds

ANALYTICAL DATES REPORT

Sample ID	Client Sample ID	Matrix	Test Number	Test Name	Batch ID	Dilution	Analysis Date	Run ID
1905168-03A	H-27	Aqueous	M3500-Fe D	Ferric Iron (Calculated)	91002	1	05/24/19	UV/VIS_2_190524A
	H-27	Aqueous	M3500-Fe D	Ferrous Iron	91002	1	05/20/19 03:56 PM	UV/VIS_2_190520A
1905168-03B	H-27	Aqueous	SW7470A	Mercury Total: Aqueous	91017	1	05/22/19 10:29 AM	CETAC2_HG_190522 A
	H-27	Aqueous	SW6020A	Trace Metals: ICP-MS - Water	90959	1	05/20/19 03:47 PM	ICP-MS4_190520B
	H-27	Aqueous	SW6020A	Trace Metals: ICP-MS - Water	90959	10	05/21/19 12:59 PM	ICP-MS5_190521A
	H-27	Aqueous	SW6020A	Trace Metals: ICP-MS - Water	90959	1	05/21/19 02:14 PM	ICP-MS5_190521A
1905168-03C	H-27	Aqueous	M2320 B	Alkalinity	90940	1	05/16/19 04:20 PM	TITRATOR_190516A
	H-27	Aqueous	E300	Anions by IC method - Water	90908	10	05/15/19 02:59 PM	IC2_190515A
	H-27	Aqueous	E300	Anions by IC method - Water	90908	1	05/15/19 06:27 PM	IC2_190515A
	H-27	Aqueous	M4500-P E	Orthophosphate	90921	1	05/15/19 12:49 PM	UV/VIS_2_190515B
	H-27	Aqueous	M2540C	Total Dissolved Solids	90953	1	05/17/19 11:40 AM	WC_190517D
1905168-04A	H-29	Aqueous	M3500-Fe D	Ferric Iron (Calculated)	91002	1	05/24/19	UV/VIS_2_190524A
	H-29	Aqueous	M3500-Fe D	Ferrous Iron	91002	1	05/20/19 03:56 PM	UV/VIS_2_190520A
1905168-04B	H-29	Aqueous	SW7470A	Mercury Total: Aqueous	91017	1	05/22/19 10:31 AM	CETAC2_HG_190522 A
	H-29	Aqueous	SW6020A	Trace Metals: ICP-MS - Water	90959	1	05/20/19 03:49 PM	ICP-MS4_190520B
	H-29	Aqueous	SW6020A	Trace Metals: ICP-MS - Water	90959	1	05/21/19 02:55 PM	ICP-MS5_190521A
	H-29	Aqueous	SW6020A	Trace Metals: ICP-MS - Water	90959	20	05/21/19 01:01 PM	ICP-MS5_190521A
1905168-04C	H-29	Aqueous	M2320 B	Alkalinity	90940	1	05/16/19 04:23 PM	TITRATOR_190516A
	H-29	Aqueous	E300	Anions by IC method - Water	90908	10	05/15/19 03:15 PM	IC2_190515A
	H-29	Aqueous	E300	Anions by IC method - Water	90908	1	05/15/19 06:43 PM	IC2_190515A
	H-29	Aqueous	M4500-P E	Orthophosphate	90921	1	05/15/19 12:49 PM	UV/VIS_2_190515B
	H-29	Aqueous	M2540C	Total Dissolved Solids	90953	1	05/17/19 11:40 AM	WC_190517D
1905168-05A	H-28	Aqueous	M3500-Fe D	Ferric Iron (Calculated)	91002	1	05/24/19	UV/VIS_2_190524A
	H-28	Aqueous	M3500-Fe D	Ferrous Iron	91002	1	05/20/19 03:57 PM	UV/VIS_2_190520A
1905168-05B	H-28	Aqueous	SW7470A	Mercury Total: Aqueous	91017	1	05/22/19 10:34 AM	CETAC2_HG_190522 A
	H-28	Aqueous	SW6020A	Trace Metals: ICP-MS - Water	90959	20	05/21/19 01:03 PM	ICP-MS5_190521A

Lab Order: 1905168
 Client: Golder
 Project: Luminant-MLSES Ash Ponds

ANALYTICAL DATES REPORT

Sample ID	Client Sample ID	Matrix	Test Number	Test Name	Batch ID	Dilution	Analysis Date	Run ID
1905168-05B	H-28	Aqueous	SW6020A	Trace Metals: ICP-MS - Water	90959	1	05/21/19 02:57 PM	ICP-MS5_190521A
	H-28	Aqueous	SW6020A	Trace Metals: ICP-MS - Water	90959	1	05/20/19 03:51 PM	ICP-MS4_190520B
1905168-05C	H-28	Aqueous	M2320 B	Alkalinity	90940	1	05/16/19 04:27 PM	TITRATOR_190516A
	H-28	Aqueous	E300	Anions by IC method - Water	90908	10	05/15/19 03:31 PM	IC2_190515A
	H-28	Aqueous	E300	Anions by IC method - Water	90908	1	05/15/19 06:59 PM	IC2_190515A
	H-28	Aqueous	M4500-P E	Orthophosphate	90921	1	05/15/19 12:50 PM	UV/VIS_2_190515B
	H-28	Aqueous	M2540C	Total Dissolved Solids	90953	1	05/17/19 11:40 AM	WC_190517D
1905168-06A	H-26	Aqueous	M3500-Fe D	Ferric Iron (Calculated)	91002	1	05/24/19	UV/VIS_2_190524A
	H-26	Aqueous	M3500-Fe D	Ferrous Iron	91002	1	05/20/19 03:57 PM	UV/VIS_2_190520A
1905168-06B	H-26	Aqueous	SW7470A	Mercury Total: Aqueous	91017	1	05/22/19 10:36 AM	CETAC2_HG_190522 A
	H-26	Aqueous	SW6020A	Trace Metals: ICP-MS - Water	90959	1	05/20/19 03:53 PM	ICP-MS4_190520B
	H-26	Aqueous	SW6020A	Trace Metals: ICP-MS - Water	90959	10	05/21/19 01:05 PM	ICP-MS5_190521A
	H-26	Aqueous	SW6020A	Trace Metals: ICP-MS - Water	90959	1	05/21/19 02:16 PM	ICP-MS5_190521A
1905168-06C	H-26	Aqueous	M2320 B	Alkalinity	90940	1	05/16/19 04:42 PM	TITRATOR_190516A
	H-26	Aqueous	E300	Anions by IC method - Water	90908	10	05/15/19 03:47 PM	IC2_190515A
	H-26	Aqueous	E300	Anions by IC method - Water	90908	1	05/15/19 07:15 PM	IC2_190515A
	H-26	Aqueous	M4500-P E	Orthophosphate	90921	1	05/15/19 12:50 PM	UV/VIS_2_190515B
	H-26	Aqueous	M2540C	Total Dissolved Solids	90953	1	05/17/19 11:40 AM	WC_190517D
1905168-07A	H-33	Aqueous	M3500-Fe D	Ferric Iron (Calculated)	91002	1	05/24/19	UV/VIS_2_190524A
	H-33	Aqueous	M3500-Fe D	Ferrous Iron	91002	1	05/20/19 03:58 PM	UV/VIS_2_190520A
1905168-07B	H-33	Aqueous	SW7470A	Mercury Total: Aqueous	91017	1	05/22/19 10:38 AM	CETAC2_HG_190522 A
	H-33	Aqueous	SW6020A	Trace Metals: ICP-MS - Water	90959	1	05/20/19 03:54 PM	ICP-MS4_190520B
	H-33	Aqueous	SW6020A	Trace Metals: ICP-MS - Water	90959	10	05/21/19 01:08 PM	ICP-MS5_190521A
	H-33	Aqueous	SW6020A	Trace Metals: ICP-MS - Water	90959	1	05/21/19 02:19 PM	ICP-MS5_190521A
1905168-07C	H-33	Aqueous	M2320 B	Alkalinity	90940	1	05/16/19 04:49 PM	TITRATOR_190516A
	H-33	Aqueous	E300	Anions by IC method - Water	90908	10	05/15/19 04:03 PM	IC2_190515A
	H-33	Aqueous	E300	Anions by IC method - Water	90908	1	05/15/19 07:31 PM	IC2_190515A

Lab Order: 1905168
Client: Golder
Project: Luminant-MLSES Ash Ponds

ANALYTICAL DATES REPORT

Sample ID	Client Sample ID	Matrix	Test Number	Test Name	Batch ID	Dilution	Analysis Date	Run ID
1905168-07C	H-33	Aqueous	M4500-P E	Orthophosphate	90921	1	05/15/19 12:50 PM	UV/VIS_2_190515B
	H-33	Aqueous	M2540C	Total Dissolved Solids	90953	1	05/17/19 11:40 AM	WC_190517D

LUMINANT

CLIENT: Golder
Project: Luminant-MLSES Ash Ponds
Project No: 19122262-C
Lab Order: 1905168

Client Sample ID: H-31
Lab ID: 1905168-01
Collection Date: 05/14/19 07:40 AM
Matrix: AQUEOUS

Analyses	Result	MDL	RL	Qual	Units	DF	Date Analyzed
TRACE METALS: ICP-MS - WATER		SW6020A		Analyst: RO			
Antimony	<0.000800	0.000800	0.00250		mg/L	1	05/20/19 03:43 PM
Arsenic	0.00675	0.00200	0.00500		mg/L	1	05/20/19 03:43 PM
Barium	0.0163	0.00300	0.0100		mg/L	1	05/20/19 03:43 PM
Beryllium	0.00928	0.000300	0.00100		mg/L	1	05/20/19 03:43 PM
Boron	20.0	0.500	1.50		mg/L	50	05/21/19 12:54 PM
Cadmium	<0.000300	0.000300	0.00100		mg/L	1	05/20/19 03:43 PM
Calcium	234	5.00	15.0		mg/L	50	05/21/19 12:54 PM
Chromium	0.00315	0.00200	0.00500	J	mg/L	1	05/20/19 03:43 PM
Cobalt	0.389	0.00300	0.00500		mg/L	1	05/20/19 03:43 PM
Iron	48.7	1.50	5.00		mg/L	50	05/21/19 12:54 PM
Lead	<0.000300	0.000300	0.00100		mg/L	1	05/20/19 03:43 PM
Lithium	0.219	0.00500	0.0100		mg/L	1	05/20/19 03:43 PM
Magnesium	170	5.00	15.0		mg/L	50	05/21/19 12:54 PM
Molybdenum	<0.00200	0.00200	0.00500		mg/L	1	05/21/19 02:51 PM
Potassium	6.18	0.100	0.300		mg/L	1	05/20/19 03:43 PM
Selenium	0.0261	0.00200	0.00500		mg/L	1	05/20/19 03:43 PM
Sodium	672	5.00	15.0		mg/L	50	05/21/19 12:54 PM
Thallium	<0.000500	0.000500	0.00150		mg/L	1	05/20/19 03:43 PM
MERCURY TOTAL: AQUEOUS		SW7470A		Analyst: BM			
Mercury	<0.000400	0.000400	0.00100		mg/L	5	05/22/19 11:21 AM
ANIONS BY IC METHOD - WATER		E300		Analyst: JL			
Chloride	225	3.00	10.0		mg/L	10	05/15/19 02:27 PM
Fluoride	0.960	0.100	0.400		mg/L	1	05/15/19 05:55 PM
Nitrate-N	<0.100	0.100	0.500		mg/L	1	05/15/19 05:55 PM
Sulfate	2470	100	300		mg/L	100	05/16/19 05:42 PM
ALKALINITY		M2320 B		Analyst: CC			
Alkalinity, Bicarbonate (As CaCO3)	33.9	10.0	20.0		mg/L @ pH 4.52	1	05/16/19 04:13 PM
Alkalinity, Carbonate (As CaCO3)	<10.0	10.0	20.0		mg/L @ pH 4.52	1	05/16/19 04:13 PM
Alkalinity, Hydroxide (As CaCO3)	<10.0	10.0	20.0		mg/L @ pH 4.52	1	05/16/19 04:13 PM
Alkalinity, Total (As CaCO3)	33.9	20.0	20.0		mg/L @ pH 4.52	1	05/16/19 04:13 PM
FERRIC IRON (CALCULATED)		M3500-FE D		Analyst: CAC			
Iron, Ferric	<0.0500	0.0500	0.100	N	mg/L	1	05/24/19
FERROUS IRON		M3500-FE D		Analyst: BTJ			
Iron, Ferrous	49.5	5.00	10.0	N	mg/L	100	05/20/19 04:11 PM

Qualifiers: * Value exceeds TCLP Maximum Concentration Level C Sample Result or QC discussed in the Case Narrative
 DF Dilution Factor E TPH pattern not Gas or Diesel Range Pattern
 J Analyte detected between MDL and RL MDL Method Detection Limit
 ND Not Detected at the Method Detection Limit RL Reporting Limit
 S Spike Recovery outside control limits N Parameter not NELAP certified

DHL Analytical, Inc.

Date: 14-Jun-19

CLIENT: Golder
Project: Luminant-MLSES Ash Ponds
Project No: 19122262-C
Lab Order: 1905168

Client Sample ID: H-31
Lab ID: 1905168-01
Collection Date: 05/14/19 07:40 AM
Matrix: AQUEOUS

Analyses	Result	MDL	RL	Qual	Units	DF	Date Analyzed
ORTHOPHOSPHATE							Analyst: CC
Phosphorus, Total Orthophosphate (As P)	0.0770	0.0300	0.100	J	mg/L	1	05/15/19 02:47 PM
TOTAL DISSOLVED SOLIDS							Analyst: JS
Total Dissolved Solids (Residue, Filterable)	4230	50.0	50.0		mg/L	1	05/17/19 11:40 AM

LUMINANT

Qualifiers:

*	Value exceeds TCLP Maximum Concentration Level	C	Sample Result or QC discussed in the Case Narrative
DF	Dilution Factor	E	TPH pattern not Gas or Diesel Range Pattern
J	Analyte detected between MDL and RL	MDL	Method Detection Limit
ND	Not Detected at the Method Detection Limit	RL	Reporting Limit
S	Spike Recovery outside control limits	N	Parameter not NELAP certified

CLIENT: Golder
 Project: Luminant-MLSES Ash Ponds
 Project No: 19122262-C
 Lab Order: 1905168

Client Sample ID: H-32
 Lab ID: 1905168-02
 Collection Date: 05/14/19 08:25 AM
 Matrix: AQUEOUS

Analyses	Result	MDL	RL	Qual	Units	DF	Date Analyzed
TRACE METALS: ICP-MS - WATER		SW6020A		Analyst: RO			
Antimony	<0.000800	0.000800	0.00250		mg/L	1	05/20/19 03:45 PM
Arsenic	0.00202	0.00200	0.00500	J	mg/L	1	05/20/19 03:45 PM
Barium	0.0162	0.00300	0.0100		mg/L	1	05/20/19 03:45 PM
Beryllium	0.00713	0.000300	0.00100		mg/L	1	05/20/19 03:45 PM
Boron	2.08	0.100	0.300		mg/L	10	05/21/19 12:56 PM
Cadmium	0.000366	0.000300	0.00100	J	mg/L	1	05/20/19 03:45 PM
Calcium	45.2	1.00	3.00		mg/L	10	05/21/19 12:56 PM
Chromium	<0.00200	0.00200	0.00500		mg/L	1	05/20/19 03:45 PM
Cobalt	0.202	0.00300	0.00500		mg/L	1	05/20/19 03:45 PM
Iron	1.81	0.0300	0.100		mg/L	1	05/20/19 03:45 PM
Lead	0.000574	0.000300	0.00100	J	mg/L	1	05/20/19 03:45 PM
Lithium	0.0978	0.00500	0.0100		mg/L	1	05/20/19 03:45 PM
Magnesium	18.5	0.100	0.300		mg/L	1	05/20/19 03:45 PM
Molybdenum	<0.00200	0.00200	0.00500		mg/L	1	05/21/19 02:53 PM
Potassium	2.57	0.100	0.300		mg/L	1	05/20/19 03:45 PM
Selenium	0.00675	0.00200	0.00500		mg/L	1	05/20/19 03:45 PM
Sodium	151	1.00	3.00		mg/L	10	05/21/19 12:56 PM
Thallium	<0.000500	0.000500	0.00150		mg/L	1	05/20/19 03:45 PM
MERCURY TOTAL: AQUEOUS		SW7470A		Analyst: BM			
Mercury	<0.0000800	0.0000800	0.000200		mg/L	1	05/22/19 10:27 AM
ANIONS BY IC METHOD - WATER		E300		Analyst: JL			
Chloride	135	3.00	10.0		mg/L	10	05/15/19 02:43 PM
Fluoride	1.15	0.100	0.400		mg/L	1	05/15/19 06:11 PM
Nitrate-N	273	1.00	5.00		mg/L	10	05/15/19 02:43 PM
Sulfate	320	10.0	30.0		mg/L	10	05/15/19 02:43 PM
ALKALINITY		M2320 B		Analyst: CC			
Alkalinity, Bicarbonate (As CaCO3)	<10.0	10.0	20.0		mg/L @ pH 1.76	1	05/16/19 04:15 PM
Alkalinity, Carbonate (As CaCO3)	<10.0	10.0	20.0		mg/L @ pH 1.76	1	05/16/19 04:15 PM
Alkalinity, Hydroxide (As CaCO3)	<10.0	10.0	20.0		mg/L @ pH 1.76	1	05/16/19 04:15 PM
Alkalinity, Total (As CaCO3)	<20.0	20.0	20.0		mg/L @ pH 1.76	1	05/16/19 04:15 PM
FERRIC IRON (CALCULATED)		M3500-FE D		Analyst: CAC			
Iron, Ferric	0.640	0.0500	0.100	N	mg/L	1	05/24/19
FERROUS IRON		M3500-FE D		Analyst: BTJ			
Iron, Ferrous	1.17	0.250	0.500	N	mg/L	5	05/20/19 04:11 PM

Qualifiers: * Value exceeds TCLP Maximum Concentration Level C Sample Result or QC discussed in the Case Narrative
 DF Dilution Factor E TPH pattern not Gas or Diesel Range Pattern
 J Analyte detected between MDL and RL MDL Method Detection Limit
 ND Not Detected at the Method Detection Limit RL Reporting Limit
 S Spike Recovery outside control limits N Parameter not NELAP certified

DHL Analytical, Inc.

Date: 14-Jun-19

CLIENT: Golder
Project: Luminant-MLSES Ash Ponds
Project No: 19122262-C
Lab Order: 1905168

Client Sample ID: H-32
Lab ID: 1905168-02
Collection Date: 05/14/19 08:25 AM
Matrix: AQUEOUS

Analyses	Result	MDL	RL	Qual	Units	DF	Date Analyzed
ORTHOPHOSPHATE							Analyst: CC
Phosphorus, Total Orthophosphate (As P)	0.0600	0.0300	0.100	J	mg/L	1	05/15/19 12:49 PM
TOTAL DISSOLVED SOLIDS							Analyst: JS
Total Dissolved Solids (Residue, Filterable)	910	50.0	50.0		mg/L	1	05/17/19 11:40 AM

LUMINANT

Qualifiers:	*	Value exceeds TCLP Maximum Concentration Level	C	Sample Result or QC discussed in the Case Narrative
	DF	Dilution Factor	E	TPH pattern not Gas or Diesel Range Pattern
	J	Analyte detected between MDL and RL	MDL	Method Detection Limit
	ND	Not Detected at the Method Detection Limit	RL	Reporting Limit
	S	Spike Recovery outside control limits	N	Parameter not NELAP certified

CLIENT: Golder
Project: Luminant-MLSES Ash Ponds
Project No: 19122262-C
Lab Order: 1905168

Client Sample ID: H-27
Lab ID: 1905168-03
Collection Date: 05/14/19 09:40 AM
Matrix: AQUEOUS

Analyses	Result	MDL	RL	Qual	Units	DF	Date Analyzed
TRACE METALS: ICP-MS - WATER		SW6020A		Analyst: RO			
Antimony	<0.000800	0.000800	0.00250		mg/L	1	05/20/19 03:47 PM
Arsenic	<0.00200	0.00200	0.00500		mg/L	1	05/20/19 03:47 PM
Barium	0.0208	0.00300	0.0100		mg/L	1	05/20/19 03:47 PM
Beryllium	<0.000300	0.000300	0.00100		mg/L	1	05/20/19 03:47 PM
Boron	0.350	0.0100	0.0300		mg/L	1	05/21/19 02:14 PM
Cadmium	<0.000300	0.000300	0.00100		mg/L	1	05/20/19 03:47 PM
Calcium	61.8	1.00	3.00		mg/L	10	05/21/19 12:59 PM
Chromium	<0.00200	0.00200	0.00500		mg/L	1	05/20/19 03:47 PM
Cobalt	<0.00300	0.00300	0.00500		mg/L	1	05/20/19 03:47 PM
Iron	0.0711	0.0300	0.100	J	mg/L	1	05/20/19 03:47 PM
Lead	<0.000300	0.000300	0.00100		mg/L	1	05/20/19 03:47 PM
Lithium	0.0678	0.00500	0.0100		mg/L	1	05/20/19 03:47 PM
Magnesium	47.3	1.00	3.00		mg/L	10	05/21/19 12:59 PM
Molybdenum	<0.00200	0.00200	0.00500		mg/L	1	05/21/19 02:14 PM
Potassium	3.01	0.100	0.300		mg/L	1	05/20/19 03:47 PM
Selenium	<0.00200	0.00200	0.00500		mg/L	1	05/20/19 03:47 PM
Sodium	123	1.00	3.00		mg/L	10	05/21/19 12:59 PM
Thallium	<0.000500	0.000500	0.00150		mg/L	1	05/20/19 03:47 PM
MERCURY TOTAL: AQUEOUS		SW7470A		Analyst: BM			
Mercury	<0.0000800	0.0000800	0.000200		mg/L	1	05/22/19 10:29 AM
ANIONS BY IC METHOD - WATER		E300		Analyst: JL			
Chloride	132	3.00	10.0		mg/L	10	05/15/19 02:59 PM
Fluoride	0.159	0.100	0.400	J	mg/L	1	05/15/19 06:27 PM
Nitrate-N	0.658	0.100	0.500		mg/L	1	05/15/19 06:27 PM
Sulfate	406	10.0	30.0		mg/L	10	05/15/19 02:59 PM
ALKALINITY		M2320 B		Analyst: CC			
Alkalinity, Bicarbonate (As CaCO3)	49.0	10.0	20.0		mg/L @ pH 4.5	1	05/16/19 04:20 PM
Alkalinity, Carbonate (As CaCO3)	<10.0	10.0	20.0		mg/L @ pH 4.5	1	05/16/19 04:20 PM
Alkalinity, Hydroxide (As CaCO3)	<10.0	10.0	20.0		mg/L @ pH 4.5	1	05/16/19 04:20 PM
Alkalinity, Total (As CaCO3)	49.0	20.0	20.0		mg/L @ pH 4.5	1	05/16/19 04:20 PM
FERRIC IRON (CALCULATED)		M3500-FE D		Analyst: CAC			
Iron, Ferric	0.0711	0.0500	0.100	JN	mg/L	1	05/24/19
FERROUS IRON		M3500-FE D		Analyst: BTJ			
Iron, Ferrous	<0.0500	0.0500	0.100	N	mg/L	1	05/20/19 03:56 PM

Qualifiers: * Value exceeds TCLP Maximum Concentration Level C Sample Result or QC discussed in the Case Narrative
 DF Dilution Factor E TPH pattern not Gas or Diesel Range Pattern
 J Analyte detected between MDL and RL MDL Method Detection Limit
 ND Not Detected at the Method Detection Limit RL Reporting Limit
 S Spike Recovery outside control limits N Parameter not NELAP certified

DHL Analytical, Inc.

Date: 14-Jun-19

CLIENT: Golder
Project: Luminant-MLSES Ash Ponds
Project No: 19122262-C
Lab Order: 1905168

Client Sample ID: H-27
Lab ID: 1905168-03
Collection Date: 05/14/19 09:40 AM
Matrix: AQUEOUS

Analyses	Result	MDL	RL	Qual	Units	DF	Date Analyzed
ORTHOPHOSPHATE							Analyst: CC
Phosphorus, Total Orthophosphate (As P)	0.126	0.0300	0.100		mg/L	1	05/15/19 12:49 PM
TOTAL DISSOLVED SOLIDS							Analyst: JS
Total Dissolved Solids (Residue, Filterable)	897	10.0	10.0		mg/L	1	05/17/19 11:40 AM

LUMINANT

Qualifiers:

*	Value exceeds TCLP Maximum Concentration Level	C	Sample Result or QC discussed in the Case Narrative
DF	Dilution Factor	E	TPH pattern not Gas or Diesel Range Pattern
J	Analyte detected between MDL and RL	MDL	Method Detection Limit
ND	Not Detected at the Method Detection Limit	RL	Reporting Limit
S	Spike Recovery outside control limits	N	Parameter not NELAP certified

CLIENT: Golder
Project: Luminant-MLSES Ash Ponds
Project No: 19122262-C
Lab Order: 1905168

Client Sample ID: H-29
Lab ID: 1905168-04
Collection Date: 05/14/19 11:25 AM
Matrix: AQUEOUS

Analyses	Result	MDL	RL	Qual	Units	DF	Date Analyzed
TRACE METALS: ICP-MS - WATER		SW6020A			Analyst: RO		
Antimony	<0.000800	0.000800	0.00250		mg/L	1	05/20/19 03:49 PM
Arsenic	<0.00200	0.00200	0.00500		mg/L	1	05/20/19 03:49 PM
Barium	0.0138	0.00300	0.0100		mg/L	1	05/20/19 03:49 PM
Beryllium	0.00341	0.000300	0.00100		mg/L	1	05/20/19 03:49 PM
Boron	8.12	0.200	0.600		mg/L	20	05/21/19 01:01 PM
Cadmium	0.00219	0.000300	0.00100		mg/L	1	05/20/19 03:49 PM
Calcium	95.9	2.00	6.00		mg/L	20	05/21/19 01:01 PM
Chromium	<0.00200	0.00200	0.00500		mg/L	1	05/20/19 03:49 PM
Cobalt	0.183	0.00300	0.00500		mg/L	1	05/20/19 03:49 PM
Iron	0.0521	0.0300	0.100	J	mg/L	1	05/20/19 03:49 PM
Lead	0.000543	0.000300	0.00100	J	mg/L	1	05/20/19 03:49 PM
Lithium	0.173	0.00500	0.0100		mg/L	1	05/20/19 03:49 PM
Magnesium	80.5	2.00	6.00		mg/L	20	05/21/19 01:01 PM
Molybdenum	<0.00200	0.00200	0.00500		mg/L	1	05/21/19 02:55 PM
Potassium	2.01	0.100	0.300		mg/L	1	05/20/19 03:49 PM
Selenium	0.00616	0.00200	0.00500		mg/L	1	05/20/19 03:49 PM
Sodium	211	2.00	6.00		mg/L	20	05/21/19 01:01 PM
Thallium	<0.000500	0.000500	0.00150		mg/L	1	05/20/19 03:49 PM
MERCURY TOTAL: AQUEOUS		SW7470A			Analyst: BM		
Mercury	<0.0000800	0.0000800	0.000200		mg/L	1	05/22/19 10:31 AM
ANIONS BY IC METHOD - WATER		E300			Analyst: JL		
Chloride	81.8	3.00	10.0		mg/L	10	05/15/19 03:15 PM
Fluoride	0.104	0.100	0.400	J	mg/L	1	05/15/19 06:43 PM
Nitrate-N	0.121	0.100	0.500	J	mg/L	1	05/15/19 06:43 PM
Sulfate	780	10.0	30.0		mg/L	10	05/15/19 03:15 PM
ALKALINITY		M2320 B			Analyst: CC		
Alkalinity, Bicarbonate (As CaCO3)	<10.0	10.0	20.0		mg/L @ pH 4.5	1	05/16/19 04:23 PM
Alkalinity, Carbonate (As CaCO3)	<10.0	10.0	20.0		mg/L @ pH 4.5	1	05/16/19 04:23 PM
Alkalinity, Hydroxide (As CaCO3)	<10.0	10.0	20.0		mg/L @ pH 4.5	1	05/16/19 04:23 PM
Alkalinity, Total (As CaCO3)	<20.0	20.0	20.0		mg/L @ pH 4.5	1	05/16/19 04:23 PM
FERRIC IRON (CALCULATED)		M3500-FE D			Analyst: CAC		
Iron, Ferric	0.0521	0.0500	0.100	JN	mg/L	1	05/24/19
FERROUS IRON		M3500-FE D			Analyst: BTJ		
Iron, Ferrous	<0.0500	0.0500	0.100	N	mg/L	1	05/20/19 03:56 PM

Qualifiers: * Value exceeds TCLP Maximum Concentration Level C Sample Result or QC discussed in the Case Narrative
 DF Dilution Factor E TPH pattern not Gas or Diesel Range Pattern
 J Analyte detected between MDL and RL MDL Method Detection Limit
 ND Not Detected at the Method Detection Limit RL Reporting Limit
 S Spike Recovery outside control limits N Parameter not NELAP certified

DHL Analytical, Inc.

Date: 14-Jun-19

CLIENT: Golder
Project: Luminant-MLSES Ash Ponds
Project No: 19122262-C
Lab Order: 1905168

Client Sample ID: H-29
Lab ID: 1905168-04
Collection Date: 05/14/19 11:25 AM
Matrix: AQUEOUS

Analyses	Result	MDL	RL	Qual	Units	DF	Date Analyzed
ORTHOPHOSPHATE							Analyst: CC
Phosphorus, Total Orthophosphate (As P)	0.0570	0.0300	0.100	J	mg/L	1	05/15/19 12:49 PM
TOTAL DISSOLVED SOLIDS							Analyst: JS
Total Dissolved Solids (Residue, Filterable)	1400	50.0	50.0		mg/L	1	05/17/19 11:40 AM

LUMINANT

Qualifiers:

*	Value exceeds TCLP Maximum Concentration Level	C	Sample Result or QC discussed in the Case Narrative
DF	Dilution Factor	E	TPH pattern not Gas or Diesel Range Pattern
J	Analyte detected between MDL and RL	MDL	Method Detection Limit
ND	Not Detected at the Method Detection Limit	RL	Reporting Limit
S	Spike Recovery outside control limits	N	Parameter not NELAP certified

DHL Analytical, Inc.

Date: 14-Jun-19

CLIENT: Golder
Project: Luminant-MLSES Ash Ponds
Project No: 19122262-C
Lab Order: 1905168

Client Sample ID: H-28
Lab ID: 1905168-05
Collection Date: 05/14/19 12:30 PM
Matrix: AQUEOUS

Analyses	Result	MDL	RL	Qual	Units	DF	Date Analyzed
TRACE METALS: ICP-MS - WATER		SW6020A			Analyst: RO		
Antimony	<0.000800	0.000800	0.00250		mg/L	1	05/20/19 03:51 PM
Arsenic	<0.00200	0.00200	0.00500		mg/L	1	05/20/19 03:51 PM
Barium	0.0141	0.00300	0.0100		mg/L	1	05/20/19 03:51 PM
Beryllium	0.00281	0.000300	0.00100		mg/L	1	05/20/19 03:51 PM
Boron	8.51	0.200	0.600		mg/L	20	05/21/19 01:03 PM
Cadmium	0.00212	0.000300	0.00100		mg/L	1	05/20/19 03:51 PM
Calcium	99.7	2.00	6.00		mg/L	20	05/21/19 01:03 PM
Chromium	<0.00200	0.00200	0.00500		mg/L	1	05/20/19 03:51 PM
Cobalt	0.187	0.00300	0.00500		mg/L	1	05/20/19 03:51 PM
Iron	0.0715	0.0300	0.100	J	mg/L	1	05/20/19 03:51 PM
Lead	0.000595	0.000300	0.00100	J	mg/L	1	05/20/19 03:51 PM
Lithium	0.172	0.00500	0.0100		mg/L	1	05/20/19 03:51 PM
Magnesium	81.4	2.00	6.00		mg/L	20	05/21/19 01:03 PM
Molybdenum	<0.00200	0.00200	0.00500		mg/L	1	05/21/19 02:57 PM
Potassium	2.06	0.100	0.300		mg/L	1	05/20/19 03:51 PM
Selenium	0.00619	0.00200	0.00500		mg/L	1	05/20/19 03:51 PM
Sodium	210	2.00	6.00		mg/L	20	05/21/19 01:03 PM
Thallium	<0.000500	0.000500	0.00150		mg/L	1	05/20/19 03:51 PM
MERCURY TOTAL: AQUEOUS		SW7470A			Analyst: BM		
Mercury	<0.0000800	0.0000800	0.000200		mg/L	1	05/22/19 10:34 AM
ANIONS BY IC METHOD - WATER		E300			Analyst: JL		
Chloride	98.9	3.00	10.0		mg/L	10	05/15/19 03:31 PM
Fluoride	<0.100	0.100	0.400		mg/L	1	05/15/19 06:59 PM
Nitrate-N	<0.100	0.100	0.500		mg/L	1	05/15/19 06:59 PM
Sulfate	935	10.0	30.0		mg/L	10	05/15/19 03:31 PM
ALKALINITY		M2320 B			Analyst: CC		
Alkalinity, Bicarbonate (As CaCO3)	<10.0	10.0	20.0		mg/L @ pH 4.5	1	05/16/19 04:27 PM
Alkalinity, Carbonate (As CaCO3)	<10.0	10.0	20.0		mg/L @ pH 4.5	1	05/16/19 04:27 PM
Alkalinity, Hydroxide (As CaCO3)	<10.0	10.0	20.0		mg/L @ pH 4.5	1	05/16/19 04:27 PM
Alkalinity, Total (As CaCO3)	<20.0	20.0	20.0		mg/L @ pH 4.5	1	05/16/19 04:27 PM
FERRIC IRON (CALCULATED)		M3500-FE D			Analyst: CAC		
Iron, Ferric	0.0715	0.0500	0.100	JN	mg/L	1	05/24/19
FERROUS IRON		M3500-FE D			Analyst: BTJ		
Iron, Ferrous	<0.0500	0.0500	0.100	N	mg/L	1	05/20/19 03:57 PM

Qualifiers:	* Value exceeds TCLP Maximum Concentration Level	C Sample Result or QC discussed in the Case Narrative
DF	Dilution Factor	E TPH pattern not Gas or Diesel Range Pattern
J	Analyte detected between MDL and RL	MDL Method Detection Limit
ND	Not Detected at the Method Detection Limit	RL Reporting Limit
S	Spike Recovery outside control limits	N Parameter not NELAP certified

DHL Analytical, Inc.

Date: 14-Jun-19

CLIENT: Golder
Project: Luminant-MLSES Ash Ponds
Project No: 19122262-C
Lab Order: 1905168

Client Sample ID: H-28
Lab ID: 1905168-05
Collection Date: 05/14/19 12:30 PM
Matrix: AQUEOUS

Analyses	Result	MDL	RL	Qual	Units	DF	Date Analyzed
ORTHOPHOSPHATE							Analyst: CC
Phosphorus, Total Orthophosphate (As P)	0.0460	0.0300	0.100	J	mg/L	1	05/15/19 12:50 PM
TOTAL DISSOLVED SOLIDS							Analyst: JS
Total Dissolved Solids (Residue, Filterable)	1680	50.0	50.0		mg/L	1	05/17/19 11:40 AM

LUMINANT

Qualifiers:

*	Value exceeds TCLP Maximum Concentration Level	C	Sample Result or QC discussed in the Case Narrative
DF	Dilution Factor	E	TPH pattern not Gas or Diesel Range Pattern
J	Analyte detected between MDL and RL	MDL	Method Detection Limit
ND	Not Detected at the Method Detection Limit	RL	Reporting Limit
S	Spike Recovery outside control limits	N	Parameter not NELAP certified

CLIENT: Golder
 Project: Luminant-MLSES Ash Ponds
 Project No: 19122262-C
 Lab Order: 1905168

Client Sample ID: H-26
 Lab ID: 1905168-06
 Collection Date: 05/14/19 02:25 PM
 Matrix: AQUEOUS

Analyses	Result	MDL	RL	Qual	Units	DF	Date Analyzed
TRACE METALS: ICP-MS - WATER		SW6020A		Analyst: RO			
Antimony	<0.000800	0.000800	0.00250		mg/L	1	05/20/19 03:53 PM
Arsenic	0.00410	0.00200	0.00500	J	mg/L	1	05/20/19 03:53 PM
Barium	0.190	0.00300	0.0100		mg/L	1	05/20/19 03:53 PM
Beryllium	0.00147	0.000300	0.00100		mg/L	1	05/20/19 03:53 PM
Boron	0.0507	0.0100	0.0300		mg/L	1	05/21/19 02:16 PM
Cadmium	<0.000300	0.000300	0.00100		mg/L	1	05/20/19 03:53 PM
Calcium	85.2	1.00	3.00		mg/L	10	05/21/19 01:05 PM
Chromium	0.0406	0.00200	0.00500		mg/L	1	05/20/19 03:53 PM
Cobalt	0.0795	0.00300	0.00500		mg/L	1	05/20/19 03:53 PM
Iron	8.81	0.0300	0.100		mg/L	1	05/20/19 03:53 PM
Lead	0.000972	0.000300	0.00100	J	mg/L	1	05/20/19 03:53 PM
Lithium	0.147	0.00500	0.0100		mg/L	1	05/20/19 03:53 PM
Magnesium	9.31	0.100	0.300		mg/L	1	05/20/19 03:53 PM
Molybdenum	<0.00200	0.00200	0.00500		mg/L	1	05/21/19 02:16 PM
Potassium	11.6	0.100	0.300		mg/L	1	05/20/19 03:53 PM
Selenium	0.00222	0.00200	0.00500	J	mg/L	1	05/20/19 03:53 PM
Sodium	69.5	1.00	3.00		mg/L	10	05/21/19 01:05 PM
Thallium	<0.000500	0.000500	0.00150		mg/L	1	05/20/19 03:53 PM
MERCURY TOTAL: AQUEOUS		SW7470A		Analyst: BM			
Mercury	<0.0000800	0.0000800	0.000200		mg/L	1	05/22/19 10:36 AM
ANIONS BY IC METHOD - WATER		E300		Analyst: JL			
Chloride	61.7	3.00	10.0		mg/L	10	05/15/19 03:47 PM
Fluoride	0.140	0.100	0.400	J	mg/L	1	05/15/19 07:15 PM
Nitrate-N	0.239	0.100	0.500	J	mg/L	1	05/15/19 07:15 PM
Sulfate	88.2	1.00	3.00		mg/L	1	05/15/19 07:15 PM
ALKALINITY		M2320 B		Analyst: CC			
Alkalinity, Bicarbonate (As CaCO3)	157	10.0	20.0		mg/L @ pH 4.51	1	05/16/19 04:42 PM
Alkalinity, Carbonate (As CaCO3)	<10.0	10.0	20.0		mg/L @ pH 4.51	1	05/16/19 04:42 PM
Alkalinity, Hydroxide (As CaCO3)	<10.0	10.0	20.0		mg/L @ pH 4.51	1	05/16/19 04:42 PM
Alkalinity, Total (As CaCO3)	157	20.0	20.0		mg/L @ pH 4.51	1	05/16/19 04:42 PM
FERRIC IRON (CALCULATED)		M3500-FE D		Analyst: CAC			
Iron, Ferric	8.81	0.0500	0.100	N	mg/L	1	05/24/19
FERROUS IRON		M3500-FE D		Analyst: BTJ			
Iron, Ferrous	<0.0500	0.0500	0.100	N	mg/L	1	05/20/19 03:57 PM

Qualifiers: * Value exceeds TCLP Maximum Concentration Level C Sample Result or QC discussed in the Case Narrative
 DF Dilution Factor E TPH pattern not Gas or Diesel Range Pattern
 J Analyte detected between MDL and RL MDL Method Detection Limit
 ND Not Detected at the Method Detection Limit RL Reporting Limit
 S Spike Recovery outside control limits N Parameter not NELAP certified

DHL Analytical, Inc.

Date: 14-Jun-19

CLIENT: Golder
Project: Luminant-MLSES Ash Ponds
Project No: 19122262-C
Lab Order: 1905168

Client Sample ID: H-26
Lab ID: 1905168-06
Collection Date: 05/14/19 02:25 PM
Matrix: AQUEOUS

Analyses	Result	MDL	RL	Qual	Units	DF	Date Analyzed
ORTHOPHOSPHATE							Analyst: CC
Phosphorus, Total Orthophosphate (As P)	0.0310	0.0300	0.100	J	mg/L	1	05/15/19 12:50 PM
TOTAL DISSOLVED SOLIDS							Analyst: JS
Total Dissolved Solids (Residue, Filterable)	453	10.0	10.0		mg/L	1	05/17/19 11:40 AM

LUMINANT

Qualifiers:

*	Value exceeds TCLP Maximum Concentration Level	C	Sample Result or QC discussed in the Case Narrative
DF	Dilution Factor	E	TPH pattern not Gas or Diesel Range Pattern
J	Analyte detected between MDL and RL	MDL	Method Detection Limit
ND	Not Detected at the Method Detection Limit	RL	Reporting Limit
S	Spike Recovery outside control limits	N	Parameter not NELAP certified

CLIENT: Golder
Project: Luminant-MLSES Ash Ponds
Project No: 19122262-C
Lab Order: 1905168

Client Sample ID: H-33
Lab ID: 1905168-07
Collection Date: 05/14/19 03:30 PM
Matrix: AQUEOUS

Analyses	Result	MDL	RL	Qual	Units	DF	Date Analyzed
TRACE METALS: ICP-MS - WATER		SW6020A			Analyst: RO		
Antimony	<0.000800	0.000800	0.00250		mg/L	1	05/20/19 03:54 PM
Arsenic	0.00355	0.00200	0.00500	J	mg/L	1	05/20/19 03:54 PM
Barium	0.158	0.00300	0.0100		mg/L	1	05/20/19 03:54 PM
Beryllium	0.00114	0.000300	0.00100		mg/L	1	05/20/19 03:54 PM
Boron	0.0592	0.0100	0.0300		mg/L	1	05/21/19 02:19 PM
Cadmium	<0.000300	0.000300	0.00100		mg/L	1	05/20/19 03:54 PM
Calcium	68.6	1.00	3.00		mg/L	10	05/21/19 01:08 PM
Chromium	0.0342	0.00200	0.00500		mg/L	1	05/20/19 03:54 PM
Cobalt	0.0648	0.00300	0.00500		mg/L	1	05/20/19 03:54 PM
Iron	7.61	0.0300	0.100		mg/L	1	05/20/19 03:54 PM
Lead	0.000772	0.000300	0.00100	J	mg/L	1	05/20/19 03:54 PM
Lithium	0.161	0.00500	0.0100		mg/L	1	05/20/19 03:54 PM
Magnesium	10.6	0.100	0.300		mg/L	1	05/20/19 03:54 PM
Molybdenum	<0.00200	0.00200	0.00500		mg/L	1	05/21/19 02:19 PM
Potassium	13.2	0.100	0.300		mg/L	1	05/20/19 03:54 PM
Selenium	<0.00200	0.00200	0.00500		mg/L	1	05/20/19 03:54 PM
Sodium	79.5	1.00	3.00		mg/L	10	05/21/19 01:08 PM
Thallium	<0.000500	0.000500	0.00150		mg/L	1	05/20/19 03:54 PM
MERCURY TOTAL: AQUEOUS		SW7470A			Analyst: BM		
Mercury	<0.0000800	0.0000800	0.000200		mg/L	1	05/22/19 10:38 AM
ANIONS BY IC METHOD - WATER		E300			Analyst: JL		
Chloride	80.4	3.00	10.0		mg/L	10	05/15/19 04:03 PM
Fluoride	0.166	0.100	0.400	J	mg/L	1	05/15/19 07:31 PM
Nitrate-N	0.287	0.100	0.500	J	mg/L	1	05/15/19 07:31 PM
Sulfate	104	10.0	30.0		mg/L	10	05/15/19 04:03 PM
ALKALINITY		M2320 B			Analyst: CC		
Alkalinity, Bicarbonate (As CaCO3)	181	10.0	20.0		mg/L @ pH 4.51	1	05/16/19 04:49 PM
Alkalinity, Carbonate (As CaCO3)	<10.0	10.0	20.0		mg/L @ pH 4.51	1	05/16/19 04:49 PM
Alkalinity, Hydroxide (As CaCO3)	<10.0	10.0	20.0		mg/L @ pH 4.51	1	05/16/19 04:49 PM
Alkalinity, Total (As CaCO3)	181	20.0	20.0		mg/L @ pH 4.51	1	05/16/19 04:49 PM
FERRIC IRON (CALCULATED)		M3500-FE D			Analyst: CAC		
Iron, Ferric	7.61	0.0500	0.100	N	mg/L	1	05/24/19
FERROUS IRON		M3500-FE D			Analyst: BTJ		
Iron, Ferrous	<0.0500	0.0500	0.100	N	mg/L	1	05/20/19 03:58 PM

Qualifiers: * Value exceeds TCLP Maximum Concentration Level C Sample Result or QC discussed in the Case Narrative
 DF Dilution Factor E TPH pattern not Gas or Diesel Range Pattern
 J Analyte detected between MDL and RL MDL Method Detection Limit
 ND Not Detected at the Method Detection Limit RL Reporting Limit
 S Spike Recovery outside control limits N Parameter not NELAP certified

DHL Analytical, Inc.

Date: 14-Jun-19

CLIENT: Golder
Project: Luminant-MLSES Ash Ponds
Project No: 19122262-C
Lab Order: 1905168

Client Sample ID: H-33
Lab ID: 1905168-07
Collection Date: 05/14/19 03:30 PM
Matrix: AQUEOUS

Analyses	Result	MDL	RL	Qual	Units	DF	Date Analyzed
ORTHOPHOSPHATE							Analyst: CC
Phosphorus, Total Orthophosphate (As P)	0.123	0.0300	0.100		mg/L	1	05/15/19 12:50 PM
TOTAL DISSOLVED SOLIDS							Analyst: JS
Total Dissolved Solids (Residue, Filterable)	559	10.0	10.0		mg/L	1	05/17/19 11:40 AM

LUMINANT

Qualifiers:

*	Value exceeds TCLP Maximum Concentration Level	C	Sample Result or QC discussed in the Case Narrative
DF	Dilution Factor	E	TPH pattern not Gas or Diesel Range Pattern
J	Analyte detected between MDL and RL	MDL	Method Detection Limit
ND	Not Detected at the Method Detection Limit	RL	Reporting Limit
S	Spike Recovery outside control limits	N	Parameter not NELAP certified

CLIENT: Golder
Work Order: 1905168

ANALYTICAL QC SUMMARY REPORT

Project: Luminant-MLSES Ash Ponds

RunID: CETAC2_HG_190522A

The QC data in batch 91017 applies to the following samples: 1905168-01B, 1905168-02B, 1905168-03B, 1905168-04B, 1905168-05B, 1905168-06B, 1905168-07B

Sample ID MB-91017	Batch ID: 91017	TestNo: SW7470A	Units: mg/L
SampType: MBLK	Run ID: CETAC2_HG_190522A	Analysis Date: 5/22/2019 10:02:31 AM	Prep Date: 5/21/2019

Analyte	Result	RL	SPK value	Ref Val	%REC	LowLimit	HighLimit	%RPD	RPDLimit	Qual
Mercury	<0.0000800	0.000200								

Sample ID LCS-91017	Batch ID: 91017	TestNo: SW7470A	Units: mg/L
SampType: LCS	Run ID: CETAC2_HG_190522A	Analysis Date: 5/22/2019 10:04:46 AM	Prep Date: 5/21/2019

Analyte	Result	RL	SPK value	Ref Val	%REC	LowLimit	HighLimit	%RPD	RPDLimit	Qual
Mercury	0.00187	0.000200	0.00200	0	93.5	85	115			

Sample ID LCSD-91017	Batch ID: 91017	TestNo: SW7470A	Units: mg/L
SampType: LCSD	Run ID: CETAC2_HG_190522A	Analysis Date: 5/22/2019 10:07:02 AM	Prep Date: 5/21/2019

Analyte	Result	RL	SPK value	Ref Val	%REC	LowLimit	HighLimit	%RPD	RPDLimit	Qual
Mercury	0.00186	0.000200	0.00200	0	93.0	85	115	0.536	15	

Sample ID 1905168-01B MS	Batch ID: 91017	TestNo: SW7470A	Units: mg/L
SampType: MS	Run ID: CETAC2_HG_190522A	Analysis Date: 5/22/2019 11:23:23 AM	Prep Date: 5/21/2019

Analyte	Result	RL	SPK value	Ref Val	%REC	LowLimit	HighLimit	%RPD	RPDLimit	Qual
Mercury	0.00196	0.00100	0.00200	0	97.8	80	120			

Sample ID 1905168-01B MSD	Batch ID: 91017	TestNo: SW7470A	Units: mg/L
SampType: MSD	Run ID: CETAC2_HG_190522A	Analysis Date: 5/22/2019 11:25:39 AM	Prep Date: 5/21/2019

Analyte	Result	RL	SPK value	Ref Val	%REC	LowLimit	HighLimit	%RPD	RPDLimit	Qual
Mercury	0.00194	0.00100	0.00200	0	97.0	80	120	0.770	15	

Sample ID 1905168-01B SD	Batch ID: 91017	TestNo: SW7470A	Units: mg/L
SampType: SD	Run ID: CETAC2_HG_190522A	Analysis Date: 5/22/2019 11:27:56 AM	Prep Date: 5/21/2019

Analyte	Result	RL	SPK value	Ref Val	%REC	LowLimit	HighLimit	%RPD	RPDLimit	Qual
Mercury	<0.00200	0.00500	0	0				0	10	

Sample ID 1905168-01B PDS	Batch ID: 91017	TestNo: SW7470A	Units: mg/L
SampType: PDS	Run ID: CETAC2_HG_190522A	Analysis Date: 5/22/2019 11:30:13 AM	Prep Date: 5/21/2019

Analyte	Result	RL	SPK value	Ref Val	%REC	LowLimit	HighLimit	%RPD	RPDLimit	Qual
Mercury	0.0122	0.00100	0.0125	0	97.6	85	115			

- Qualifiers:**
- B Analyte detected in the associated Method Blank
 - J Analyte detected between MDL and RL
 - ND Not Detected at the Method Detection Limit
 - RL Reporting Limit
 - J Analyte detected between SDL and RL
 - DF Dilution Factor
 - MDL Method Detection Limit
 - R RPD outside accepted control limits
 - S Spike Recovery outside control limits
 - N Parameter not NELAP certified

CLIENT: Golder
Work Order: 1905168
Project: Luminant-MLSES Ash Ponds

ANALYTICAL QC SUMMARY REPORT

RunID: CETAC2_HG_190522A

Sample ID ICV-190522	Batch ID: R104223	TestNo: SW7470A	Units: mg/L							
SampType: ICV	Run ID: CETAC2_HG_190522A	Analysis Date: 5/22/2019 9:57:56 AM	Prep Date:							
Analyte	Result	RL	SPK value	Ref Val	%REC	LowLimit	HighLimit	%RPD	RPDLimit	Qual

Mercury	0.00383	0.000200	0.00400	0	95.8	90	110			
---------	---------	----------	---------	---	------	----	-----	--	--	--

Sample ID CCV1-190522	Batch ID: R104223	TestNo: SW7470A	Units: mg/L							
SampType: CCV	Run ID: CETAC2_HG_190522A	Analysis Date: 5/22/2019 10:41:04 AM	Prep Date:							
Analyte	Result	RL	SPK value	Ref Val	%REC	LowLimit	HighLimit	%RPD	RPDLimit	Qual

Mercury	0.00202	0.000200	0.00200	0	101	90	110			
---------	---------	----------	---------	---	-----	----	-----	--	--	--

Sample ID CCV2-190522	Batch ID: R104223	TestNo: SW7470A	Units: mg/L							
SampType: CCV	Run ID: CETAC2_HG_190522A	Analysis Date: 5/22/2019 11:08:23 AM	Prep Date:							
Analyte	Result	RL	SPK value	Ref Val	%REC	LowLimit	HighLimit	%RPD	RPDLimit	Qual

Mercury	0.00203	0.000200	0.00200	0	102	90	110			
---------	---------	----------	---------	---	-----	----	-----	--	--	--

Sample ID CCV3-190522	Batch ID: R104223	TestNo: SW7470A	Units: mg/L							
SampType: CCV	Run ID: CETAC2_HG_190522A	Analysis Date: 5/22/2019 2:51:11 PM	Prep Date:							
Analyte	Result	RL	SPK value	Ref Val	%REC	LowLimit	HighLimit	%RPD	RPDLimit	Qual

Mercury	0.00203	0.000200	0.00200	0	102	90	110			
---------	---------	----------	---------	---	-----	----	-----	--	--	--

<p>Qualifiers:</p> <p>B Analyte detected in the associated Method Blank</p> <p>J Analyte detected between MDL and RL</p> <p>ND Not Detected at the Method Detection Limit</p> <p>RL Reporting Limit</p> <p>J Analyte detected between SDL and RL</p>	<p>DF Dilution Factor</p> <p>MDL Method Detection Limit</p> <p>R RPD outside accepted control limits</p> <p>S Spike Recovery outside control limits</p> <p>N Parameter not NELAP certified</p>
---	--

CLIENT: Golder
Work Order: 1905168
Project: Luminant-MLSES Ash Ponds

ANALYTICAL QC SUMMARY REPORT

RunID: ICP-MS4_190520B

The QC data in batch 90959 applies to the following samples: 1905168-01B, 1905168-02B, 1905168-03B, 1905168-04B, 1905168-05B, 1905168-06B, 1905168-07B

Sample ID: MB-90959	Batch ID: 90959	TestNo: SW6020A	Units: mg/L
SampType: MBLK	Run ID: ICP-MS4_190520B	Analysis Date: 5/20/2019 3:23:00 PM	Prep Date: 5/17/2019

Analyte	Result	RL	SPK value	Ref Val	%REC	LowLimit	HighLimit	%RPD	RPDLimit	Qual
Antimony	<0.000800	0.00250								
Arsenic	<0.00200	0.00500								
Barium	<0.00300	0.0100								
Beryllium	<0.000300	0.00100								
Cadmium	<0.000300	0.00100								
Calcium	<0.100	0.300								
Chromium	<0.00200	0.00500								
Cobalt	<0.00300	0.00500								
Iron	<0.0300	0.100								
Lead	<0.000300	0.00100								
Lithium	<0.00500	0.0100								
Magnesium	<0.100	0.300								
Potassium	<0.100	0.300								
Selenium	<0.00200	0.00500								
Sodium	<0.100	0.300								
Thallium	<0.000500	0.00150								

Sample ID: LCS-90959	Batch ID: 90959	TestNo: SW6020A	Units: mg/L
SampType: LCS	Run ID: ICP-MS4_190520B	Analysis Date: 5/20/2019 3:27:00 PM	Prep Date: 5/17/2019

Analyte	Result	RL	SPK value	Ref Val	%REC	LowLimit	HighLimit	%RPD	RPDLimit	Qual
Antimony	0.190	0.00250	0.200	0	94.8	80	120			
Arsenic	0.204	0.00500	0.200	0	102	80	120			
Barium	0.190	0.0100	0.200	0	94.9	80	120			
Beryllium	0.211	0.00100	0.200	0	105	80	120			
Cadmium	0.192	0.00100	0.200	0	95.8	80	120			
Calcium	4.65	0.300	5.00	0	93.1	80	120			
Chromium	0.195	0.00500	0.200	0	97.7	80	120			
Cobalt	0.203	0.00500	0.200	0	101	80	120			
Iron	5.14	0.100	5.00	0	103	80	120			
Lead	0.187	0.00100	0.200	0	93.6	80	120			
Lithium	0.217	0.0100	0.200	0	108	80	120			
Magnesium	5.03	0.300	5.00	0	101	80	120			
Potassium	5.02	0.300	5.00	0	100	80	120			
Selenium	0.204	0.00500	0.200	0	102	80	120			
Sodium	5.07	0.300	5.00	0	101	80	120			
Thallium	0.199	0.00150	0.200	0	99.7	80	120			

Qualifiers: B Analyte detected in the associated Method Blank DF Dilution Factor
J Analyte detected between MDL and RL MDL Method Detection Limit
ND Not Detected at the Method Detection Limit R RPD outside accepted control limits
RL Reporting Limit S Spike Recovery outside control limits
J Analyte detected between SDL and RL N Parameter not NELAP certified

CLIENT: Golder
Work Order: 1905168
Project: Luminant-MLSES Ash Ponds

ANALYTICAL QC SUMMARY REPORT

RunID: ICP-MS4_190520B

Sample ID: LCSD-90959	Batch ID: 90959	TestNo: SW6020A	Units: mg/L
SampType: LCSD	Run ID: ICP-MS4_190520B	Analysis Date: 5/20/2019 3:29:00 PM	Prep Date: 5/17/2019

Analyte	Result	RL	SPK value	Ref Val	%REC	LowLimit	HighLimit	%RPD	RPDLimit	Qual
Antimony	0.195	0.00250	0.200	0	97.7	80	120	2.98	15	
Arsenic	0.201	0.00500	0.200	0	100	80	120	1.34	15	
Barium	0.194	0.0100	0.200	0	97.2	80	120	2.37	15	
Beryllium	0.210	0.00100	0.200	0	105	80	120	0.345	15	
Cadmium	0.198	0.00100	0.200	0	98.8	80	120	3.14	15	
Calcium	4.68	0.300	5.00	0	93.5	80	120	0.492	15	
Chromium	0.198	0.00500	0.200	0	99.1	80	120	1.40	15	
Cobalt	0.200	0.00500	0.200	0	100	80	120	1.46	15	
Iron	5.15	0.100	5.00	0	103	80	120	0.209	15	
Lead	0.190	0.00100	0.200	0	95.0	80	120	1.54	15	
Lithium	0.211	0.0100	0.200	0	106	80	120	2.37	15	
Magnesium	5.15	0.300	5.00	0	103	80	120	2.30	15	
Potassium	5.07	0.300	5.00	0	101	80	120	1.08	15	
Selenium	0.200	0.00500	0.200	0	99.9	80	120	1.96	15	
Sodium	5.10	0.300	5.00	0	102	80	120	0.502	15	
Thallium	0.200	0.00150	0.200	0	100	80	120	0.279	15	

Sample ID: 1905178-02C SD	Batch ID: 90959	TestNo: SW6020A	Units: mg/L
SampType: SD	Run ID: ICP-MS4_190520B	Analysis Date: 5/20/2019 3:37:00 PM	Prep Date: 5/17/2019

Analyte	Result	RL	SPK value	Ref Val	%REC	LowLimit	HighLimit	%RPD	RPDLimit	Qual
Antimony	<0.00400	0.0125	0	0				0	10	
Arsenic	0.0115	0.0250	0	0.0113				1.19	10	
Barium	0.0249	0.0500	0	0.0269				7.62	10	
Beryllium	<0.00150	0.00500	0	0				0	10	
Cadmium	<0.00150	0.00500	0	0				0	10	
Chromium	0.0104	0.0250	0	0.0104				0.596	10	
Cobalt	<0.0150	0.0250	0	0				0	10	
Iron	0.313	0.500	0	0.303				3.55	10	
Lead	<0.00150	0.00500	0	0				0	10	
Lithium	0.0378	0.0500	0	0.0361				4.57	10	
Potassium	1.53	1.50	0	1.52				0.244	10	
Selenium	<0.0100	0.0250	0	0				0	10	
Thallium	<0.00250	0.00750	0	0				0	10	

Sample ID: 1905178-02C PDS	Batch ID: 90959	TestNo: SW6020A	Units: mg/L
SampType: PDS	Run ID: ICP-MS4_190520B	Analysis Date: 5/20/2019 3:56:00 PM	Prep Date: 5/17/2019

Analyte	Result	RL	SPK value	Ref Val	%REC	LowLimit	HighLimit	%RPD	RPDLimit	Qual
Antimony	0.193	0.00250	0.200	0	96.4	80	120			
Arsenic	0.209	0.00500	0.200	0.0113	98.9	80	120			

Qualifiers:

B	Analyte detected in the associated Method Blank	DF	Dilution Factor
J	Analyte detected between MDL and RL	MDL	Method Detection Limit
ND	Not Detected at the Method Detection Limit	R	RPD outside accepted control limits
RL	Reporting Limit	S	Spike Recovery outside control limits
J	Analyte detected between SDL and RL	N	Parameter not NELAP certified

CLIENT: Golder
Work Order: 1905168
Project: Luminant-MLSES Ash Ponds

ANALYTICAL QC SUMMARY REPORT

RunID: ICP-MS4_190520B

Sample ID: 1905178-02C PDS	Batch ID: 90959	TestNo: SW6020A	Units: mg/L
SampType: PDS	Run ID: ICP-MS4_190520B	Analysis Date: 5/20/2019 3:56:00 PM	Prep Date: 5/17/2019

Analyte	Result	RL	SPK value	Ref Val	%REC	LowLimit	HighLimit	%RPD	RPDLimit	Qual
Barium	0.214	0.0100	0.200	0.0269	93.7	80	120			
Beryllium	0.184	0.00100	0.200	0	91.9	80	120			
Cadmium	0.184	0.00100	0.200	0	91.8	80	120			
Chromium	0.198	0.00500	0.200	0.0104	93.6	80	120			
Cobalt	0.193	0.00500	0.200	0	96.5	80	120			
Iron	5.19	0.100	5.00	0.303	97.7	80	120			
Lead	0.185	0.00100	0.200	0	92.4	80	120			
Lithium	0.224	0.0100	0.200	0.0361	93.9	80	120			
Potassium	6.27	0.300	5.00	1.52	94.9	80	120			
Selenium	0.195	0.00500	0.200	0	97.6	80	120			
Thallium	0.203	0.00150	0.200	0	101	80	120			

Sample ID: 1905178-02C MS	Batch ID: 90959	TestNo: SW6020A	Units: mg/L
SampType: MS	Run ID: ICP-MS4_190520B	Analysis Date: 5/20/2019 3:58:00 PM	Prep Date: 5/17/2019

Analyte	Result	RL	SPK value	Ref Val	%REC	LowLimit	HighLimit	%RPD	RPDLimit	Qual
Antimony	0.197	0.00250	0.200	0	98.3	80	120			
Arsenic	0.217	0.00500	0.200	0.0113	103	80	120			
Barium	0.223	0.0100	0.200	0.0269	97.8	80	120			
Beryllium	0.187	0.00100	0.200	0	93.6	80	120			
Cadmium	0.185	0.00100	0.200	0	92.5	80	120			
Calcium	65.6	0.300	5.00	62.5	62.2	80	120			S
Chromium	0.198	0.00500	0.200	0.0104	93.7	80	120			
Cobalt	0.196	0.00500	0.200	0	98.1	80	120			
Iron	5.25	0.100	5.00	0.303	98.9	80	120			
Lead	0.188	0.00100	0.200	0	93.9	80	120			
Lithium	0.221	0.0100	0.200	0.0361	92.5	80	120			
Magnesium	65.8	0.300	5.00	63.5	45.8	80	120			S
Potassium	6.56	0.300	5.00	1.52	101	80	120			
Selenium	0.204	0.00500	0.200	0	102	80	120			
Sodium	223	0.300	5.00	229	-120	80	120			S
Thallium	0.201	0.00150	0.200	0	100	80	120			

Sample ID: 1905178-02C MSD	Batch ID: 90959	TestNo: SW6020A	Units: mg/L
SampType: MSD	Run ID: ICP-MS4_190520B	Analysis Date: 5/20/2019 4:00:00 PM	Prep Date: 5/17/2019

Analyte	Result	RL	SPK value	Ref Val	%REC	LowLimit	HighLimit	%RPD	RPDLimit	Qual
Antimony	0.199	0.00250	0.200	0	99.4	80	120	1.06	15	
Arsenic	0.214	0.00500	0.200	0.0113	101	80	120	1.22	15	
Barium	0.228	0.0100	0.200	0.0269	100	80	120	2.27	15	
Beryllium	0.186	0.00100	0.200	0	92.8	80	120	0.831	15	

Qualifiers:

B	Analyte detected in the associated Method Blank	DF	Dilution Factor
J	Analyte detected between MDL and RL	MDL	Method Detection Limit
ND	Not Detected at the Method Detection Limit	R	RPD outside accepted control limits
RL	Reporting Limit	S	Spike Recovery outside control limits
J	Analyte detected between SDL and RL	N	Parameter not NELAP certified

CLIENT: Golder
Work Order: 1905168
Project: Luminant-MLSES Ash Ponds

ANALYTICAL QC SUMMARY REPORT

RunID: ICP-MS4_190520B

Sample ID: 1905178-02C MSD	Batch ID: 90959	TestNo: SW6020A	Units: mg/L
SampType: MSD	Run ID: ICP-MS4_190520B	Analysis Date: 5/20/2019 4:00:00 PM	Prep Date: 5/17/2019

Analyte	Result	RL	SPK value	Ref Val	%REC	LowLimit	HighLimit	%RPD	RPDLimit	Qual
Cadmium	0.188	0.00100	0.200	0	94.1	80	120	1.65	15	
Calcium	65.6	0.300	5.00	62.5	61.4	80	120	0.058	15	S
Chromium	0.197	0.00500	0.200	0.0104	93.2	80	120	0.455	15	
Cobalt	0.195	0.00500	0.200	0	97.6	80	120	0.571	15	
Iron	5.20	0.100	5.00	0.303	97.9	80	120	0.922	15	
Lead	0.186	0.00100	0.200	0	93.1	80	120	0.842	15	
Lithium	0.227	0.0100	0.200	0.0361	95.5	80	120	2.65	15	
Magnesium	66.6	0.300	5.00	63.5	62.8	80	120	1.28	15	S
Potassium	6.53	0.300	5.00	1.52	100	80	120	0.365	15	
Selenium	0.201	0.00500	0.200	0	101	80	120	1.07	15	
Sodium	224	0.300	5.00	229	-105	80	120	0.347	15	S
Thallium	0.205	0.00150	0.200	0	103	80	120	2.13	15	

LUMINANT

Qualifiers: B Analyte detected in the associated Method Blank J Analyte detected between MDL and RL ND Not Detected at the Method Detection Limit RL Reporting Limit J Analyte detected between SDL and RL	DF Dilution Factor MDL Method Detection Limit R RPD outside accepted control limits S Spike Recovery outside control limits N Parameter not NELAP certified
--	---

CLIENT: Golder
Work Order: 1905168
Project: Luminant-MLSES Ash Ponds

ANALYTICAL QC SUMMARY REPORT

RunID: ICP-MS4_190520B

Sample ID ICV-190520	Batch ID: R104182	TestNo: SW6020A	Units: mg/L
SampType: ICV	Run ID: ICP-MS4_190520B	Analysis Date: 5/20/2019 11:23:00 AM	Prep Date:

Analyte	Result	RL	SPK value	Ref Val	%REC	LowLimit	HighLimit	%RPD	RPDLimit	Qual
Antimony	0.0968	0.00250	0.100	0	96.8	90	110			
Arsenic	0.0991	0.00500	0.100	0	99.1	90	110			
Barium	0.0948	0.0100	0.100	0	94.8	90	110			
Beryllium	0.102	0.00100	0.100	0	102	90	110			
Cadmium	0.0974	0.00100	0.100	0	97.4	90	110			
Calcium	2.44	0.300	2.50	0	97.7	90	110			
Chromium	0.102	0.00500	0.100	0	102	90	110			
Cobalt	0.101	0.00500	0.100	0	101	90	110			
Iron	2.61	0.100	2.50	0	104	90	110			
Lead	0.0932	0.00100	0.100	0	93.2	90	110			
Lithium	0.106	0.0100	0.100	0	106	90	110			
Magnesium	2.50	0.300	2.50	0	100	90	110			
Potassium	2.53	0.300	2.50	0	101	90	110			
Selenium	0.0979	0.00500	0.100	0	97.9	90	110			
Sodium	2.59	0.300	2.50	0	104	90	110			
Thallium	0.0911	0.00150	0.100	0	91.1	90	110			

Sample ID LCVL-190520	Batch ID: R104182	TestNo: SW6020A	Units: mg/L
SampType: LCVL	Run ID: ICP-MS4_190520B	Analysis Date: 5/20/2019 11:29:00 AM	Prep Date:

Analyte	Result	RL	SPK value	Ref Val	%REC	LowLimit	HighLimit	%RPD	RPDLimit	Qual
Antimony	0.00176	0.00250	0.00200	0	87.9	70	130			
Arsenic	0.00489	0.00500	0.00500	0	97.7	70	130			
Barium	0.00432	0.0100	0.00500	0	86.5	70	130			
Beryllium	0.000893	0.00100	0.00100	0	89.3	70	130			
Cadmium	0.000871	0.00100	0.00100	0	87.1	70	130			
Calcium	0.0919	0.300	0.100	0	91.9	70	130			
Chromium	0.00481	0.00500	0.00500	0	96.1	70	130			
Cobalt	0.00485	0.00500	0.00500	0	97.0	70	130			
Iron	0.107	0.100	0.100	0	107	70	130			
Lead	0.000831	0.00100	0.00100	0	83.1	70	130			
Lithium	0.0104	0.0100	0.0100	0	104	70	130			
Magnesium	0.0970	0.300	0.100	0	97.0	70	130			
Potassium	0.0964	0.300	0.100	0	96.4	70	130			
Selenium	0.00489	0.00500	0.00500	0	97.8	70	130			
Sodium	0.0958	0.300	0.100	0	95.8	70	130			
Thallium	0.000816	0.00150	0.00100	0	81.6	70	130			

Qualifiers:

B Analyte detected in the associated Method Blank	DF Dilution Factor
J Analyte detected between MDL and RL	MDL Method Detection Limit
ND Not Detected at the Method Detection Limit	R RPD outside accepted control limits
RL Reporting Limit	S Spike Recovery outside control limits
J Analyte detected between SDL and RL	N Parameter not NELAP certified

CLIENT: Golder
Work Order: 1905168
Project: Luminant-MLSES Ash Ponds

ANALYTICAL QC SUMMARY REPORT

RunID: ICP-MS4_190520B

Sample ID: CCV5-190520	Batch ID: R104182	TestNo: SW6020A	Units: mg/L
SampType: CCV	Run ID: ICP-MS4_190520B	Analysis Date: 5/20/2019 2:53:00 PM	Prep Date:

Analyte	Result	RL	SPK value	Ref Val	%REC	LowLimit	HighLimit	%RPD	RPDLimit	Qual
Antimony	0.195	0.00250	0.200	0	97.6	90	110			
Arsenic	0.203	0.00500	0.200	0	102	90	110			
Barium	0.193	0.0100	0.200	0	96.5	90	110			
Beryllium	0.202	0.00100	0.200	0	101	90	110			
Cadmium	0.197	0.00100	0.200	0	98.4	90	110			
Calcium	4.64	0.300	5.00	0	92.9	90	110			
Chromium	0.195	0.00500	0.200	0	97.5	90	110			
Cobalt	0.201	0.00500	0.200	0	100	90	110			
Iron	5.06	0.100	5.00	0	101	90	110			
Lead	0.192	0.00100	0.200	0	96.1	90	110			
Lithium	0.206	0.0100	0.200	0	103	90	110			
Magnesium	5.06	0.300	5.00	0	101	90	110			
Potassium	5.03	0.300	5.00	0	101	90	110			
Selenium	0.205	0.00500	0.200	0	102	90	110			
Sodium	5.17	0.300	5.00	0	103	90	110			
Thallium	0.199	0.00150	0.200	0	99.7	90	110			

Sample ID: LCVL5-190520	Batch ID: R104182	TestNo: SW6020A	Units: mg/L
SampType: LCVL	Run ID: ICP-MS4_190520B	Analysis Date: 5/20/2019 3:01:00 PM	Prep Date:

Analyte	Result	RL	SPK value	Ref Val	%REC	LowLimit	HighLimit	%RPD	RPDLimit	Qual
Antimony	0.00174	0.00250	0.00200	0	87.2	70	130			
Arsenic	0.00487	0.00500	0.00500	0	97.5	70	130			
Barium	0.00423	0.0100	0.00500	0	84.6	70	130			
Beryllium	0.00110	0.00100	0.00100	0	110	70	130			
Cadmium	0.000921	0.00100	0.00100	0	92.1	70	130			
Calcium	0.0952	0.300	0.100	0	95.2	70	130			
Chromium	0.00485	0.00500	0.00500	0	97.1	70	130			
Cobalt	0.00489	0.00500	0.00500	0	97.9	70	130			
Iron	0.108	0.100	0.100	0	108	70	130			
Lead	0.000805	0.00100	0.00100	0	80.5	70	130			
Lithium	0.0108	0.0100	0.0100	0	108	70	130			
Magnesium	0.0983	0.300	0.100	0	98.3	70	130			
Potassium	0.0975	0.300	0.100	0	97.5	70	130			
Selenium	0.00517	0.00500	0.00500	0	103	70	130			
Sodium	0.102	0.300	0.100	0	102	70	130			
Thallium	0.000787	0.00150	0.00100	0	78.7	70	130			

Qualifiers:

B	Analyte detected in the associated Method Blank	DF	Dilution Factor
J	Analyte detected between MDL and RL	MDL	Method Detection Limit
ND	Not Detected at the Method Detection Limit	R	RPD outside accepted control limits
RL	Reporting Limit	S	Spike Recovery outside control limits
J	Analyte detected between SDL and RL	N	Parameter not NELAP certified

CLIENT: Golder
Work Order: 1905168
Project: Luminant-MLSES Ash Ponds

ANALYTICAL QC SUMMARY REPORT

RunID: ICP-MS4_190520B

Sample ID: CCV6-190520	Batch ID: R104182	TestNo: SW6020A	Units: mg/L
SampType: CCV	Run ID: ICP-MS4_190520B	Analysis Date: 5/20/2019 4:02:00 PM	Prep Date:

Analyte	Result	RL	SPK value	Ref Val	%REC	LowLimit	HighLimit	%RPD	RPDLimit	Qual
Antimony	0.194	0.00250	0.200	0	96.9	90	110			
Arsenic	0.205	0.00500	0.200	0	102	90	110			
Barium	0.192	0.0100	0.200	0	96.2	90	110			
Beryllium	0.199	0.00100	0.200	0	99.7	90	110			
Cadmium	0.193	0.00100	0.200	0	96.3	90	110			
Calcium	4.67	0.300	5.00	0	93.4	90	110			
Chromium	0.194	0.00500	0.200	0	96.8	90	110			
Cobalt	0.203	0.00500	0.200	0	101	90	110			
Iron	5.07	0.100	5.00	0	101	90	110			
Lead	0.195	0.00100	0.200	0	97.6	90	110			
Lithium	0.204	0.0100	0.200	0	102	90	110			
Magnesium	5.01	0.300	5.00	0	100	90	110			
Potassium	4.98	0.300	5.00	0	99.6	90	110			
Selenium	0.205	0.00500	0.200	0	103	90	110			
Sodium	5.14	0.300	5.00	0	103	90	110			
Thallium	0.205	0.00150	0.200	0	102	90	110			

Sample ID: LCVL6-190520	Batch ID: R104182	TestNo: SW6020A	Units: mg/L
SampType: LCVL	Run ID: ICP-MS4_190520B	Analysis Date: 5/20/2019 4:06:00 PM	Prep Date:

Analyte	Result	RL	SPK value	Ref Val	%REC	LowLimit	HighLimit	%RPD	RPDLimit	Qual
Antimony	0.00178	0.00250	0.00200	0	89.2	70	130			
Arsenic	0.00492	0.00500	0.00500	0	98.4	70	130			
Barium	0.00435	0.0100	0.00500	0	87.0	70	130			
Beryllium	0.00105	0.00100	0.00100	0	105	70	130			
Cadmium	0.000933	0.00100	0.00100	0	93.3	70	130			
Calcium	0.0988	0.300	0.100	0	98.8	70	130			
Chromium	0.00475	0.00500	0.00500	0	95.0	70	130			
Cobalt	0.00485	0.00500	0.00500	0	97.1	70	130			
Iron	0.107	0.100	0.100	0	107	70	130			
Lead	0.000828	0.00100	0.00100	0	82.8	70	130			
Lithium	0.0104	0.0100	0.0100	0	104	70	130			
Magnesium	0.0986	0.300	0.100	0	98.6	70	130			
Potassium	0.0940	0.300	0.100	0	94.0	70	130			
Selenium	0.00483	0.00500	0.00500	0	96.6	70	130			
Sodium	0.131	0.300	0.100	0	131	70	130			S
Thallium	0.000822	0.00150	0.00100	0	82.2	70	130			

Qualifiers:

B	Analyte detected in the associated Method Blank	DF	Dilution Factor
J	Analyte detected between MDL and RL	MDL	Method Detection Limit
ND	Not Detected at the Method Detection Limit	R	RPD outside accepted control limits
RL	Reporting Limit	S	Spike Recovery outside control limits
J	Analyte detected between SDL and RL	N	Parameter not NELAP certified

CLIENT: Golder
Work Order: 1905168
Project: Luminant-MLSES Ash Ponds

ANALYTICAL QC SUMMARY REPORT

RunID: ICP-MS5_190521A

The QC data in batch 90959 applies to the following samples: 1905168-01B, 1905168-02B, 1905168-03B, 1905168-04B, 1905168-05B, 1905168-06B, 1905168-07B

Sample ID MB-90959	Batch ID: 90959	TestNo: SW6020A	Units: mg/L							
SampType: MBLK	Run ID: ICP-MS5_190521A	Analysis Date: 5/21/2019 12:36:00 PM	Prep Date: 5/17/2019							
Analyte	Result	RL	SPK value	Ref Val	%REC	LowLimit	HighLimit	%RPD	RPDLimit	Qual
Boron	<0.0100	0.0300								
Molybdenum	<0.00200	0.00500								

Sample ID LCS-90959	Batch ID: 90959	TestNo: SW6020A	Units: mg/L							
SampType: LCS	Run ID: ICP-MS5_190521A	Analysis Date: 5/21/2019 12:38:00 PM	Prep Date: 5/17/2019							
Analyte	Result	RL	SPK value	Ref Val	%REC	LowLimit	HighLimit	%RPD	RPDLimit	Qual
Boron	0.201	0.0300	0.200	0	101	80	120			
Molybdenum	0.195	0.00500	0.200	0	97.3	80	120			

Sample ID LCSD-90959	Batch ID: 90959	TestNo: SW6020A	Units: mg/L							
SampType: LCSD	Run ID: ICP-MS5_190521A	Analysis Date: 5/21/2019 12:41:00 PM	Prep Date: 5/17/2019							
Analyte	Result	RL	SPK value	Ref Val	%REC	LowLimit	HighLimit	%RPD	RPDLimit	Qual
Boron	0.208	0.0300	0.200	0	104	80	120	3.23	15	
Molybdenum	0.192	0.00500	0.200	0	96.2	80	120	1.18	15	

Sample ID 1905178-02C SD	Batch ID: 90959	TestNo: SW6020A	Units: mg/L							
SampType: SD	Run ID: ICP-MS5_190521A	Analysis Date: 5/21/2019 12:47:00 PM	Prep Date: 5/17/2019							
Analyte	Result	RL	SPK value	Ref Val	%REC	LowLimit	HighLimit	%RPD	RPDLimit	Qual
Boron	<1.00	3.00	0	0.525				0	10	
Calcium	70.4	30.0	0	68.2				3.15	10	
Magnesium	63.5	30.0	0	63.5				0.085	10	
Molybdenum	<0.200	0.500	0	0				0	10	
Sodium	227	30.0	0	233				2.75	10	

Sample ID 1905178-02C PDS	Batch ID: 90959	TestNo: SW6020A	Units: mg/L							
SampType: PDS	Run ID: ICP-MS5_190521A	Analysis Date: 5/21/2019 1:14:00 PM	Prep Date: 5/17/2019							
Analyte	Result	RL	SPK value	Ref Val	%REC	LowLimit	HighLimit	%RPD	RPDLimit	Qual
Boron	4.53	0.600	4.00	0.525	100	80	120			
Calcium	170	6.00	100	68.2	102	80	120			
Magnesium	161	6.00	100	63.5	97.1	80	120			
Molybdenum	3.64	0.100	4.00	0	90.9	80	120			
Sodium	331	6.00	100	233	98.2	80	120			

Qualifiers: B Analyte detected in the associated Method Blank
J Analyte detected between MDL and RL
ND Not Detected at the Method Detection Limit
RL Reporting Limit
J Analyte detected between SDL and RL
DF Dilution Factor
MDL Method Detection Limit
R RPD outside accepted control limits
S Spike Recovery outside control limits
N Parameter not NELAP certified

CLIENT: Golder
Work Order: 1905168
Project: Luminant-MLSES Ash Ponds

ANALYTICAL QC SUMMARY REPORT

RunID: ICP-MS5_190521A

Sample ID 1905178-02C MS	Batch ID: 90959	TestNo: SW6020A	Units: mg/L							
SampType: MS	Run ID: ICP-MS5_190521A	Analysis Date: 5/21/2019 1:17:00 PM	Prep Date: 5/17/2019							
Analyte	Result	RL	SPK value	Ref Val	%REC	LowLimit	HighLimit	%RPD	RPDLimit	Qual
Boron	0.866	0.600	0.200	0.525	170	80	120			S
Molybdenum	0.192	0.100	0.200	0	96.0	80	120			

Sample ID 1905178-02C MSD	Batch ID: 90959	TestNo: SW6020A	Units: mg/L							
SampType: MSD	Run ID: ICP-MS5_190521A	Analysis Date: 5/21/2019 1:19:00 PM	Prep Date: 5/17/2019							
Analyte	Result	RL	SPK value	Ref Val	%REC	LowLimit	HighLimit	%RPD	RPDLimit	Qual
Boron	0.750	0.600	0.200	0.525	112	80	120	14.3	15	
Molybdenum	0.189	0.100	0.200	0	94.3	80	120	1.76	15	

LUMINANT

Qualifiers: B Analyte detected in the associated Method Blank J Analyte detected between MDL and RL ND Not Detected at the Method Detection Limit RL Reporting Limit J Analyte detected between SDL and RL	DF Dilution Factor MDL Method Detection Limit R RPD outside accepted control limits S Spike Recovery outside control limits N Parameter not NELAP certified
--	---

CLIENT: Golder
Work Order: 1905168
Project: Luminant-MLSES Ash Ponds

ANALYTICAL QC SUMMARY REPORT

RunID: ICP-MS5_190521A

Sample ID ICV-190521	Batch ID: R104204	TestNo: SW6020A	Units: mg/L
SampType: ICV	Run ID: ICP-MS5_190521A	Analysis Date: 5/21/2019 12:10:00 PM	Prep Date:

Analyte	Result	RL	SPK value	Ref Val	%REC	LowLimit	HighLimit	%RPD	RPDLimit	Qual
Boron	0.103	0.0300	0.100	0	103	90	110			
Calcium	2.52	0.300	2.50	0	101	90	110			
Iron	2.60	0.100	2.50	0	104	90	110			
Magnesium	2.49	0.300	2.50	0	99.7	90	110			
Molybdenum	0.0930	0.00500	0.100	0	93.0	90	110			
Sodium	2.56	0.300	2.50	0	103	90	110			

Sample ID LCVL-190521	Batch ID: R104204	TestNo: SW6020A	Units: mg/L
SampType: LCVL	Run ID: ICP-MS5_190521A	Analysis Date: 5/21/2019 12:15:00 PM	Prep Date:

Analyte	Result	RL	SPK value	Ref Val	%REC	LowLimit	HighLimit	%RPD	RPDLimit	Qual
Boron	0.0223	0.0300	0.0200	0	111	70	130			
Calcium	0.104	0.300	0.100	0	104	70	130			
Iron	0.0979	0.100	0.100	0	97.9	70	130			
Magnesium	0.0983	0.300	0.100	0	98.3	70	130			
Molybdenum	0.00464	0.00500	0.00500	0	92.8	70	130			
Sodium	0.0960	0.300	0.100	0	96.0	70	130			

Sample ID CCV1-190521	Batch ID: R104204	TestNo: SW6020A	Units: mg/L
SampType: CCV	Run ID: ICP-MS5_190521A	Analysis Date: 5/21/2019 1:26:00 PM	Prep Date:

Analyte	Result	RL	SPK value	Ref Val	%REC	LowLimit	HighLimit	%RPD	RPDLimit	Qual
Boron	0.196	0.0300	0.200	0	98.1	90	110			
Calcium	4.90	0.300	5.00	0	98.0	90	110			
Iron	5.04	0.100	5.00	0	101	90	110			
Magnesium	4.94	0.300	5.00	0	98.8	90	110			
Molybdenum	0.193	0.00500	0.200	0	96.3	90	110			
Sodium	4.93	0.300	5.00	0	98.6	90	110			

Sample ID LCVL1-190521	Batch ID: R104204	TestNo: SW6020A	Units: mg/L
SampType: LCVL	Run ID: ICP-MS5_190521A	Analysis Date: 5/21/2019 1:30:00 PM	Prep Date:

Analyte	Result	RL	SPK value	Ref Val	%REC	LowLimit	HighLimit	%RPD	RPDLimit	Qual
Boron	0.0245	0.0300	0.0200	0	123	70	130			
Calcium	0.0976	0.300	0.100	0	97.6	70	130			
Iron	0.0980	0.100	0.100	0	98.0	70	130			
Magnesium	0.0940	0.300	0.100	0	94.0	70	130			
Molybdenum	0.00478	0.00500	0.00500	0	95.6	70	130			
Sodium	0.0986	0.300	0.100	0	98.6	70	130			

Qualifiers:

B	Analyte detected in the associated Method Blank	DF	Dilution Factor
J	Analyte detected between MDL and RL	MDL	Method Detection Limit
ND	Not Detected at the Method Detection Limit	R	RPD outside accepted control limits
RL	Reporting Limit	S	Spike Recovery outside control limits
J	Analyte detected between SDL and RL	N	Parameter not NELAP certified

CLIENT: Golder
Work Order: 1905168
Project: Luminant-MLSES Ash Ponds

ANALYTICAL QC SUMMARY REPORT

RunID: ICP-MS5_190521A

Sample ID CCV2-190521	Batch ID: R104204	TestNo: SW6020A	Units: mg/L							
SampType: CCV	Run ID: ICP-MS5_190521A	Analysis Date: 5/21/2019 2:05:00 PM	Prep Date:							
Analyte	Result	RL	SPK value	Ref Val	%REC	LowLimit	HighLimit	%RPD	RPDLimit	Qual
Boron	0.208	0.0300	0.200	0	104	90	110			
Molybdenum	0.201	0.00500	0.200	0	101	90	110			

Sample ID LCVL2-190521	Batch ID: R104204	TestNo: SW6020A	Units: mg/L							
SampType: LCVL	Run ID: ICP-MS5_190521A	Analysis Date: 5/21/2019 2:09:00 PM	Prep Date:							
Analyte	Result	RL	SPK value	Ref Val	%REC	LowLimit	HighLimit	%RPD	RPDLimit	Qual
Boron	0.0258	0.0300	0.0200	0	129	70	130			
Molybdenum	0.00474	0.00500	0.00500	0	94.7	70	130			

Sample ID CCV3-190521	Batch ID: R104204	TestNo: SW6020A	Units: mg/L							
SampType: CCV	Run ID: ICP-MS5_190521A	Analysis Date: 5/21/2019 2:34:00 PM	Prep Date:							
Analyte	Result	RL	SPK value	Ref Val	%REC	LowLimit	HighLimit	%RPD	RPDLimit	Qual
Boron	0.199	0.0300	0.200	0	99.5	90	110			
Molybdenum	0.199	0.00500	0.200	0	99.7	90	110			

Sample ID LCVL3-190521	Batch ID: R104204	TestNo: SW6020A	Units: mg/L							
SampType: LCVL	Run ID: ICP-MS5_190521A	Analysis Date: 5/21/2019 2:46:00 PM	Prep Date:							
Analyte	Result	RL	SPK value	Ref Val	%REC	LowLimit	HighLimit	%RPD	RPDLimit	Qual
Boron	0.0227	0.0300	0.0200	0	113	70	130			
Molybdenum	0.00484	0.00500	0.00500	0	96.8	70	130			

Sample ID CCV4-190521	Batch ID: R104204	TestNo: SW6020A	Units: mg/L							
SampType: CCV	Run ID: ICP-MS5_190521A	Analysis Date: 5/21/2019 3:00:00 PM	Prep Date:							
Analyte	Result	RL	SPK value	Ref Val	%REC	LowLimit	HighLimit	%RPD	RPDLimit	Qual
Molybdenum	0.199	0.00500	0.200	0	99.7	90	110			

Sample ID LCVL4-190521	Batch ID: R104204	TestNo: SW6020A	Units: mg/L							
SampType: LCVL	Run ID: ICP-MS5_190521A	Analysis Date: 5/21/2019 3:05:00 PM	Prep Date:							
Analyte	Result	RL	SPK value	Ref Val	%REC	LowLimit	HighLimit	%RPD	RPDLimit	Qual
Molybdenum	0.00483	0.00500	0.00500	0	96.6	70	130			

Qualifiers:

B Analyte detected in the associated Method Blank	DF Dilution Factor
J Analyte detected between MDL and RL	MDL Method Detection Limit
ND Not Detected at the Method Detection Limit	R RPD outside accepted control limits
RL Reporting Limit	S Spike Recovery outside control limits
J Analyte detected between SDL and RL	N Parameter not NELAP certified

CLIENT: Golder
Work Order: 1905168
Project: Luminant-MLSES Ash Ponds

ANALYTICAL QC SUMMARY REPORT

RunID: IC2_190515A

The QC data in batch 90908 applies to the following samples: 1905168-01C, 1905168-02C, 1905168-03C, 1905168-04C, 1905168-05C, 1905168-06C, 1905168-07C

Sample ID: MB-90908	Batch ID: 90908	TestNo: E300	Units: mg/L
SampType: MBLK	Run ID: IC2_190515A	Analysis Date: 5/15/2019 10:10:50 AM	Prep Date: 5/15/2019

Analyte	Result	RL	SPK value	Ref Val	%REC	LowLimit	HighLimit	%RPD	RPDLimit	Qual
Chloride	<0.300	1.00								
Fluoride	<0.100	0.400								
Nitrate-N	<0.100	0.500								
Sulfate	<1.00	3.00								

Sample ID: LCS-90908	Batch ID: 90908	TestNo: E300	Units: mg/L
SampType: LCS	Run ID: IC2_190515A	Analysis Date: 5/15/2019 10:26:50 AM	Prep Date: 5/15/2019

Analyte	Result	RL	SPK value	Ref Val	%REC	LowLimit	HighLimit	%RPD	RPDLimit	Qual
Chloride	10.1	1.00	10.00	0	101	90	110			
Fluoride	4.00	0.400	4.000	0	99.9	90	110			
Nitrate-N	5.09	0.500	5.000	0	102	90	110			
Sulfate	30.4	3.00	30.00	0	101	90	110			

Sample ID: LCSD-90908	Batch ID: 90908	TestNo: E300	Units: mg/L
SampType: LCSD	Run ID: IC2_190515A	Analysis Date: 5/15/2019 10:42:50 AM	Prep Date: 5/15/2019

Analyte	Result	RL	SPK value	Ref Val	%REC	LowLimit	HighLimit	%RPD	RPDLimit	Qual
Chloride	10.2	1.00	10.00	0	102	90	110	0.674	20	
Fluoride	4.05	0.400	4.000	0	101	90	110	1.26	20	
Nitrate-N	5.08	0.500	5.000	0	102	90	110	0.146	20	
Sulfate	30.9	3.00	30.00	0	103	90	110	1.55	20	

Sample ID: 1905167-01CMS	Batch ID: 90908	TestNo: E300	Units: mg/L
SampType: MS	Run ID: IC2_190515A	Analysis Date: 5/15/2019 1:07:36 PM	Prep Date: 5/15/2019

Analyte	Result	RL	SPK value	Ref Val	%REC	LowLimit	HighLimit	%RPD	RPDLimit	Qual
Chloride	222	10.0	200.0	12.69	105	90	110			
Fluoride	211	4.00	200.0	0	106	90	110			
Nitrate-N	45.6	5.00	45.16	0	101	90	110			
Sulfate	239	30.0	200.0	41.32	98.7	90	110			

Sample ID: 1905167-01CMSD	Batch ID: 90908	TestNo: E300	Units: mg/L
SampType: MSD	Run ID: IC2_190515A	Analysis Date: 5/15/2019 1:23:36 PM	Prep Date: 5/15/2019

Analyte	Result	RL	SPK value	Ref Val	%REC	LowLimit	HighLimit	%RPD	RPDLimit	Qual
Chloride	221	10.0	200.0	12.69	104	90	110	0.308	20	
Fluoride	210	4.00	200.0	0	105	90	110	0.286	20	
Nitrate-N	45.8	5.00	45.16	0	101	90	110	0.495	20	

- Qualifiers:**
- B Analyte detected in the associated Method Blank
 - J Analyte detected between MDL and RL
 - ND Not Detected at the Method Detection Limit
 - RL Reporting Limit
 - J Analyte detected between SDL and RL
 - DF Dilution Factor
 - MDL Method Detection Limit
 - R RPD outside accepted control limits
 - S Spike Recovery outside control limits
 - N Parameter not NELAP certified

CLIENT: Golder
Work Order: 1905168
Project: Luminant-MLSES Ash Ponds

ANALYTICAL QC SUMMARY REPORT

RunID: IC2_190515A

Sample ID 1905167-01CMSD	Batch ID: 90908	TestNo: E300	Units: mg/L							
SampType: MSD	Run ID: IC2_190515A	Analysis Date: 5/15/2019 1:23:36 PM	Prep Date: 5/15/2019							
Analyte	Result	RL	SPK value	Ref Val	%REC	LowLimit	HighLimit	%RPD	RPDLimit	Qual
Sulfate	237	30.0	200.0	41.32	97.7	90	110	0.821	20	

Sample ID 1905167-02CMS	Batch ID: 90908	TestNo: E300	Units: mg/L							
SampType: MS	Run ID: IC2_190515A	Analysis Date: 5/15/2019 1:53:36 PM	Prep Date: 5/15/2019							
Analyte	Result	RL	SPK value	Ref Val	%REC	LowLimit	HighLimit	%RPD	RPDLimit	Qual
Chloride	686	10.0	200.0	528.8	78.8	90	110			S
Fluoride	229	4.00	200.0	24.26	102	90	110			
Nitrate-N	56.2	5.00	45.16	10.55	101	90	110			
Sulfate	2520	30.0	200.0	0	1260	90	110			S

Sample ID 1905167-02CMSD	Batch ID: 90908	TestNo: E300	Units: mg/L							
SampType: MSD	Run ID: IC2_190515A	Analysis Date: 5/15/2019 2:11:36 PM	Prep Date: 5/15/2019							
Analyte	Result	RL	SPK value	Ref Val	%REC	LowLimit	HighLimit	%RPD	RPDLimit	Qual
Chloride	688	10.0	200.0	528.8	79.8	90	110	0.292	20	S
Fluoride	229	4.00	200.0	24.26	102	90	110	0.251	20	
Nitrate-N	57.3	5.00	45.16	10.55	103	90	110	1.85	20	
Sulfate	<10.0	30.0	200.0	0	0	90	110	0	20	S

Qualifiers:

B	Analyte detected in the associated Method Blank	DF	Dilution Factor
J	Analyte detected between MDL and RL	MDL	Method Detection Limit
ND	Not Detected at the Method Detection Limit	R	RPD outside accepted control limits
RL	Reporting Limit	S	Spike Recovery outside control limits
J	Analyte detected between SDL and RL	N	Parameter not NELAP certified

CLIENT: Golder
Work Order: 1905168
Project: Luminant-MLSES Ash Ponds

ANALYTICAL QC SUMMARY REPORT

RunID: IC2_190515A

Sample ID ICV-190515	Batch ID: R104097	TestNo: E300	Units: mg/L							
SampType: ICV	Run ID: IC2_190515A	Analysis Date: 5/15/2019 9:38:50 AM	Prep Date:							
Analyte	Result	RL	SPK value	Ref Val	%REC	LowLimit	HighLimit	%RPD	RPDLimit	Qual
Chloride	25.8	1.00	25.00	0	103	90	110			
Fluoride	10.3	0.400	10.00	0	103	90	110			
Nitrate-N	13.0	0.500	12.50	0	104	90	110			
Sulfate	77.8	3.00	75.00	0	104	90	110			

Sample ID CCV1-190515	Batch ID: R104097	TestNo: E300	Units: mg/L							
SampType: CCV	Run ID: IC2_190515A	Analysis Date: 5/15/2019 4:51:36 PM	Prep Date:							
Analyte	Result	RL	SPK value	Ref Val	%REC	LowLimit	HighLimit	%RPD	RPDLimit	Qual
Chloride	10.4	1.00	10.00	0	104	90	110			
Fluoride	4.15	0.400	4.000	0	104	90	110			
Nitrate-N	5.13	0.500	5.000	0	103	90	110			
Sulfate	30.8	3.00	30.00	0	103	90	110			

Sample ID CCV2-190515	Batch ID: R104097	TestNo: E300	Units: mg/L							
SampType: CCV	Run ID: IC2_190515A	Analysis Date: 5/15/2019 8:35:35 PM	Prep Date:							
Analyte	Result	RL	SPK value	Ref Val	%REC	LowLimit	HighLimit	%RPD	RPDLimit	Qual
Chloride	10.6	1.00	10.00	0	106	90	110			
Fluoride	4.20	0.400	4.000	0	105	90	110			
Nitrate-N	5.20	0.500	5.000	0	104	90	110			
Sulfate	31.5	3.00	30.00	0	105	90	110			

Qualifiers:

B	Analyte detected in the associated Method Blank	DF	Dilution Factor
J	Analyte detected between MDL and RL	MDL	Method Detection Limit
ND	Not Detected at the Method Detection Limit	R	RPD outside accepted control limits
RL	Reporting Limit	S	Spike Recovery outside control limits
J	Analyte detected between SDL and RL	N	Parameter not NELAP certified

CLIENT: Golder
Work Order: 1905168
Project: Luminant-MLSES Ash Ponds

ANALYTICAL QC SUMMARY REPORT

RunID: IC4_190516A

The QC data in batch 90935 applies to the following samples: 1905168-01C

Sample ID MB-90935	Batch ID: 90935	TestNo: E300	Units: mg/L							
SampType: MBLK	Run ID: IC4_190516A	Analysis Date: 5/16/2019 10:26:21 AM	Prep Date: 5/16/2019							
Analyte	Result	RL	SPK value	Ref Val	%REC	LowLimit	HighLimit	%RPD	RPDLimit	Qual
Sulfate	<1.00	3.00								

Sample ID LCS-90935	Batch ID: 90935	TestNo: E300	Units: mg/L							
SampType: LCS	Run ID: IC4_190516A	Analysis Date: 5/16/2019 10:42:21 AM	Prep Date: 5/16/2019							
Analyte	Result	RL	SPK value	Ref Val	%REC	LowLimit	HighLimit	%RPD	RPDLimit	Qual
Sulfate	29.5	3.00	30.00	0	98.3	90	110			

Sample ID LCSD-90935	Batch ID: 90935	TestNo: E300	Units: mg/L							
SampType: LCSD	Run ID: IC4_190516A	Analysis Date: 5/16/2019 10:58:21 AM	Prep Date: 5/16/2019							
Analyte	Result	RL	SPK value	Ref Val	%REC	LowLimit	HighLimit	%RPD	RPDLimit	Qual
Sulfate	29.8	3.00	30.00	0	99.2	90	110	0.935	20	

Sample ID 1905167-02CMS	Batch ID: 90935	TestNo: E300	Units: mg/L							
SampType: MS	Run ID: IC4_190516A	Analysis Date: 5/16/2019 5:10:27 PM	Prep Date: 5/16/2019							
Analyte	Result	RL	SPK value	Ref Val	%REC	LowLimit	HighLimit	%RPD	RPDLimit	Qual
Sulfate	4830	300	2000	2897	96.9	90	110			

Sample ID 1905167-02CMSD	Batch ID: 90935	TestNo: E300	Units: mg/L							
SampType: MSD	Run ID: IC4_190516A	Analysis Date: 5/16/2019 5:26:27 PM	Prep Date: 5/16/2019							
Analyte	Result	RL	SPK value	Ref Val	%REC	LowLimit	HighLimit	%RPD	RPDLimit	Qual
Sulfate	4880	300	2000	2897	99.1	90	110	0.920	20	

Sample ID 1905168-01CMS	Batch ID: 90935	TestNo: E300	Units: mg/L							
SampType: MS	Run ID: IC4_190516A	Analysis Date: 5/16/2019 5:58:26 PM	Prep Date: 5/16/2019							
Analyte	Result	RL	SPK value	Ref Val	%REC	LowLimit	HighLimit	%RPD	RPDLimit	Qual
Sulfate	4380	300	2000	2468	95.6	90	110			

Sample ID 1905168-01CMSD	Batch ID: 90935	TestNo: E300	Units: mg/L							
SampType: MSD	Run ID: IC4_190516A	Analysis Date: 5/16/2019 6:14:27 PM	Prep Date: 5/16/2019							
Analyte	Result	RL	SPK value	Ref Val	%REC	LowLimit	HighLimit	%RPD	RPDLimit	Qual
Sulfate	4390	300	2000	2468	96.2	90	110	0.273	20	

Qualifiers:

B	Analyte detected in the associated Method Blank	DF	Dilution Factor
J	Analyte detected between MDL and RL	MDL	Method Detection Limit
ND	Not Detected at the Method Detection Limit	R	RPD outside accepted control limits
RL	Reporting Limit	S	Spike Recovery outside control limits
J	Analyte detected between SDL and RL	N	Parameter not NELAP certified

CLIENT: Golder
Work Order: 1905168
Project: Luminant-MLSES Ash Ponds

ANALYTICAL QC SUMMARY REPORT

RunID: IC4_190516A

Sample ID ICV-190516	Batch ID: R104119	TestNo: E300	Units: mg/L							
SampType: ICV	Run ID: IC4_190516A	Analysis Date: 5/16/2019 9:54:21 AM		Prep Date:						
Analyte	Result	RL	SPK value	Ref Val	%REC	LowLimit	HighLimit	%RPD	RPDLimit	Qual
Sulfate	74.5	3.00	75.00	0	99.4	90	110			

Sample ID CCV1-190516	Batch ID: R104119	TestNo: E300	Units: mg/L							
SampType: CCV	Run ID: IC4_190516A	Analysis Date: 5/16/2019 9:10:26 PM		Prep Date:						
Analyte	Result	RL	SPK value	Ref Val	%REC	LowLimit	HighLimit	%RPD	RPDLimit	Qual
Sulfate	30.2	3.00	30.00	0	101	90	110			

LUMINANT

Qualifiers:	B Analyte detected in the associated Method Blank J Analyte detected between MDL and RL ND Not Detected at the Method Detection Limit RL Reporting Limit J Analyte detected between SDL and RL	DF Dilution Factor MDL Method Detection Limit R RPD outside accepted control limits S Spike Recovery outside control limits N Parameter not NELAP certified
--------------------	---	--

CLIENT: Golder
Work Order: 1905168
Project: Luminant-MLSES Ash Ponds

ANALYTICAL QC SUMMARY REPORT

RunID: TITRATOR_190516A

The QC data in batch 90940 applies to the following samples: 1905168-01C, 1905168-02C, 1905168-03C, 1905168-04C, 1905168-05C, 1905168-06C, 1905168-07C

Sample ID: MB-90940	Batch ID: 90940	TestNo: M2320 B	Units: mg/L @ pH 4.47
SampType: MBLK	Run ID: TITRATOR_190516A	Analysis Date: 5/16/2019 2:00:00 PM	Prep Date: 5/16/2019

Analyte	Result	RL	SPK value	Ref Val	%REC	LowLimit	HighLimit	%RPD	RPDLimit	Qual
Alkalinity, Bicarbonate (As CaCO3)	<10.0	20.0								
Alkalinity, Carbonate (As CaCO3)	<10.0	20.0								
Alkalinity, Hydroxide (As CaCO3)	<10.0	20.0								
Alkalinity, Total (As CaCO3)	<20.0	20.0								

Sample ID: LCS-90940	Batch ID: 90940	TestNo: M2320 B	Units: mg/L @ pH 4.08
SampType: LCS	Run ID: TITRATOR_190516A	Analysis Date: 5/16/2019 2:04:00 PM	Prep Date: 5/16/2019

Analyte	Result	RL	SPK value	Ref Val	%REC	LowLimit	HighLimit	%RPD	RPDLimit	Qual
Alkalinity, Total (As CaCO3)	52.3	20.0	50.00	0	105	74	129			

Sample ID: 1905134-01C DUP	Batch ID: 90940	TestNo: M2320 B	Units: mg/L @ pH 4.52
SampType: DUP	Run ID: TITRATOR_190516A	Analysis Date: 5/16/2019 2:15:00 PM	Prep Date: 5/16/2019

Analyte	Result	RL	SPK value	Ref Val	%REC	LowLimit	HighLimit	%RPD	RPDLimit	Qual
Alkalinity, Bicarbonate (As CaCO3)	205	20.0	0	205.8				0.536	20	
Alkalinity, Carbonate (As CaCO3)	<10.0	20.0	0	0				0	20	
Alkalinity, Hydroxide (As CaCO3)	<10.0	20.0	0	0				0	20	
Alkalinity, Total (As CaCO3)	205	20.0	0	205.8				0.536	20	

Sample ID: 1905168-05C DUP	Batch ID: 90940	TestNo: M2320 B	Units: mg/L @ pH 4.51
SampType: DUP	Run ID: TITRATOR_190516A	Analysis Date: 5/16/2019 4:30:00 PM	Prep Date: 5/16/2019

Analyte	Result	RL	SPK value	Ref Val	%REC	LowLimit	HighLimit	%RPD	RPDLimit	Qual
Alkalinity, Bicarbonate (As CaCO3)	<10.0	20.0	0	0				0	20	
Alkalinity, Carbonate (As CaCO3)	<10.0	20.0	0	0				0	20	
Alkalinity, Hydroxide (As CaCO3)	<10.0	20.0	0	0				0	20	
Alkalinity, Total (As CaCO3)	<20.0	20.0	0	0				0	20	

<p>Qualifiers:</p> <p>B Analyte detected in the associated Method Blank</p> <p>J Analyte detected between MDL and RL</p> <p>ND Not Detected at the Method Detection Limit</p> <p>RL Reporting Limit</p> <p>J Analyte detected between SDL and RL</p>	<p>DF Dilution Factor</p> <p>MDL Method Detection Limit</p> <p>R RPD outside accepted control limits</p> <p>S Spike Recovery outside control limits</p> <p>N Parameter not NELAP certified</p>
---	--

CLIENT: Golder
Work Order: 1905168
Project: Luminant-MLSES Ash Ponds

ANALYTICAL QC SUMMARY REPORT

RunID: TITRATOR_190516A

Sample ID ICV-190516	Batch ID: R104124	TestNo: M2320 B	Units: mg/L @ pH 4.34							
SampType: ICV	Run ID: TITRATOR_190516A	Analysis Date: 5/16/2019 1:58:00 PM	Prep Date: 5/16/2019							
Analyte	Result	RL	SPK value	Ref Val	%REC	LowLimit	HighLimit	%RPD	RPDLimit	Qual

Alkalinity, Bicarbonate (As CaCO3)	8.64	20.0	0							
Alkalinity, Carbonate (As CaCO3)	89.3	20.0	0							
Alkalinity, Hydroxide (As CaCO3)	<10.0	20.0	0							
Alkalinity, Total (As CaCO3)	97.9	20.0	100.0	0	97.9	98	102			

Sample ID CCV1-190516	Batch ID: R104124	TestNo: M2320 B	Units: mg/L @ pH 4.25							
SampType: CCV	Run ID: TITRATOR_190516A	Analysis Date: 5/16/2019 3:39:00 PM	Prep Date: 5/16/2019							
Analyte	Result	RL	SPK value	Ref Val	%REC	LowLimit	HighLimit	%RPD	RPDLimit	Qual

Alkalinity, Bicarbonate (As CaCO3)	21.7	20.0	0							
Alkalinity, Carbonate (As CaCO3)	76.8	20.0	0							
Alkalinity, Hydroxide (As CaCO3)	<10.0	20.0	0							
Alkalinity, Total (As CaCO3)	98.5	20.0	100.0	0	98.5	90	110			

Sample ID CCV2-190516	Batch ID: R104124	TestNo: M2320 B	Units: mg/L @ pH 4.21							
SampType: CCV	Run ID: TITRATOR_190516A	Analysis Date: 5/16/2019 4:35:00 PM	Prep Date: 5/16/2019							
Analyte	Result	RL	SPK value	Ref Val	%REC	LowLimit	HighLimit	%RPD	RPDLimit	Qual

Alkalinity, Bicarbonate (As CaCO3)	17.7	20.0	0							
Alkalinity, Carbonate (As CaCO3)	81.3	20.0	0							
Alkalinity, Hydroxide (As CaCO3)	<10.0	20.0	0							
Alkalinity, Total (As CaCO3)	99.0	20.0	100.0	0	99.0	90	110			

Sample ID CCV3-190516	Batch ID: R104124	TestNo: M2320 B	Units: mg/L @ pH 4.39							
SampType: CCV	Run ID: TITRATOR_190516A	Analysis Date: 5/16/2019 4:54:00 PM	Prep Date: 5/16/2019							
Analyte	Result	RL	SPK value	Ref Val	%REC	LowLimit	HighLimit	%RPD	RPDLimit	Qual

Alkalinity, Bicarbonate (As CaCO3)	20.3	20.0	0							
Alkalinity, Carbonate (As CaCO3)	77.1	20.0	0							
Alkalinity, Hydroxide (As CaCO3)	<10.0	20.0	0							
Alkalinity, Total (As CaCO3)	97.4	20.0	100.0	0	97.4	90	110			

<p>Qualifiers:</p> <p>B Analyte detected in the associated Method Blank</p> <p>J Analyte detected between MDL and RL</p> <p>ND Not Detected at the Method Detection Limit</p> <p>RL Reporting Limit</p> <p>J Analyte detected between SDL and RL</p>	<p>DF Dilution Factor</p> <p>MDL Method Detection Limit</p> <p>R RPD outside accepted control limits</p> <p>S Spike Recovery outside control limits</p> <p>N Parameter not NELAP certified</p>
---	--

CLIENT: Golder
Work Order: 1905168
Project: Luminant-MLSES Ash Ponds

ANALYTICAL QC SUMMARY REPORT

RunID: UV/VIS_2_190515B

The QC data in batch 90921 applies to the following samples: 1905168-01C, 1905168-02C, 1905168-03C, 1905168-04C, 1905168-05C, 1905168-06C, 1905168-07C

Sample ID MB-90921	Batch ID: 90921	TestNo: M4500-P E	Units: mg/L							
SampType: MBLK	Run ID: UV/VIS_2_190515B	Analysis Date: 5/15/2019 12:42:00 PM	Prep Date: 5/15/2019							
Analyte	Result	RL	SPK value	Ref Val	%REC	LowLimit	HighLimit	%RPD	RPDLimit	Qual
Phosphorus, Total Orthophosphate (As	<0.0300	0.100								

Sample ID LCS-90921	Batch ID: 90921	TestNo: M4500-P E	Units: mg/L							
SampType: LCS	Run ID: UV/VIS_2_190515B	Analysis Date: 5/15/2019 12:43:00 PM	Prep Date: 5/15/2019							
Analyte	Result	RL	SPK value	Ref Val	%REC	LowLimit	HighLimit	%RPD	RPDLimit	Qual
Phosphorus, Total Orthophosphate (As	0.513	0.100	0.5000	0	103	80	120			

Sample ID LCSD-90921	Batch ID: 90921	TestNo: M4500-P E	Units: mg/L							
SampType: LCSD	Run ID: UV/VIS_2_190515B	Analysis Date: 5/15/2019 12:43:00 PM	Prep Date: 5/15/2019							
Analyte	Result	RL	SPK value	Ref Val	%REC	LowLimit	HighLimit	%RPD	RPDLimit	Qual
Phosphorus, Total Orthophosphate (As	0.504	0.100	0.5000	0	101	80	120	1.77	15	

Sample ID 1905168-01CMS	Batch ID: 90921	TestNo: M4500-P E	Units: mg/L							
SampType: MS	Run ID: UV/VIS_2_190515B	Analysis Date: 5/15/2019 12:45:00 PM	Prep Date: 5/15/2019							
Analyte	Result	RL	SPK value	Ref Val	%REC	LowLimit	HighLimit	%RPD	RPDLimit	Qual
Phosphorus, Total Orthophosphate (As	0.587	0.100	0.5000	0.07700	102	80	120			

Sample ID 1905168-01CMSD	Batch ID: 90921	TestNo: M4500-P E	Units: mg/L							
SampType: MSD	Run ID: UV/VIS_2_190515B	Analysis Date: 5/15/2019 12:45:00 PM	Prep Date: 5/15/2019							
Analyte	Result	RL	SPK value	Ref Val	%REC	LowLimit	HighLimit	%RPD	RPDLimit	Qual
Phosphorus, Total Orthophosphate (As	0.525	0.100	0.5000	0.07700	89.6	80	120	11.2	15	

Qualifiers:	<p>B Analyte detected in the associated Method Blank</p> <p>J Analyte detected between MDL and RL</p> <p>ND Not Detected at the Method Detection Limit</p> <p>RL Reporting Limit</p> <p>J Analyte detected between SDL and RL</p>	<p>DF Dilution Factor</p> <p>MDL Method Detection Limit</p> <p>R RPD outside accepted control limits</p> <p>S Spike Recovery outside control limits</p> <p>N Parameter not NELAP certified</p>
--------------------	---	--

CLIENT: Golder
Work Order: 1905168
Project: Luminant-MLSES Ash Ponds

ANALYTICAL QC SUMMARY REPORT

RunID: UV/VIS_2_190515B

Sample ID ICV-190515	Batch ID: R104071	TestNo: M4500-P E	Units: mg/L							
SampType: ICV	Run ID: UV/VIS_2_190515B	Analysis Date: 5/15/2019 12:41:00 PM	Prep Date:							
Analyte	Result	RL	SPK value	Ref Val	%REC	LowLimit	HighLimit	%RPD	RPDLimit	Qual
Phosphorus, Total Orthophosphate (As	0.204	0.100	0.2000	0	102	85	115			

Sample ID CCV1-190515	Batch ID: R104071	TestNo: M4500-P E	Units: mg/L							
SampType: CCV	Run ID: UV/VIS_2_190515B	Analysis Date: 5/15/2019 12:51:00 PM	Prep Date:							
Analyte	Result	RL	SPK value	Ref Val	%REC	LowLimit	HighLimit	%RPD	RPDLimit	Qual
Phosphorus, Total Orthophosphate (As	0.509	0.100	0.5000	0	102	85	115			

LUMINANT

Qualifiers:	<p>B Analyte detected in the associated Method Blank</p> <p>J Analyte detected between MDL and RL</p> <p>ND Not Detected at the Method Detection Limit</p> <p>RL Reporting Limit</p> <p>J Analyte detected between SDL and RL</p>	<p>DF Dilution Factor</p> <p>MDL Method Detection Limit</p> <p>R RPD outside accepted control limits</p> <p>S Spike Recovery outside control limits</p> <p>N Parameter not NELAP certified</p>
--------------------	---	--

CLIENT: Golder
Work Order: 1905168
Project: Luminant-MLSES Ash Ponds

ANALYTICAL QC SUMMARY REPORT

RunID: UV/VIS_2_190520A

The QC data in batch 91002 applies to the following samples: 1905168-01A, 1905168-02A, 1905168-03A, 1905168-04A, 1905168-05A, 1905168-06A, 1905168-07A

Sample ID: MB-91002	Batch ID: 91002	TestNo: M3500-Fe D	Units: mg/L
SampType: MBLK	Run ID: UV/VIS_2_190520A	Analysis Date: 5/20/2019 3:53:00 PM	Prep Date: 5/20/2019

Analyte	Result	RL	SPK value	Ref Val	%REC	LowLimit	HighLimit	%RPD	RPDLimit	Qual
Iron, Ferrous	<0.0500	0.100								N

Sample ID: LCS-91002	Batch ID: 91002	TestNo: M3500-Fe D	Units: mg/L
SampType: LCS	Run ID: UV/VIS_2_190520A	Analysis Date: 5/20/2019 3:53:00 PM	Prep Date: 5/20/2019

Analyte	Result	RL	SPK value	Ref Val	%REC	LowLimit	HighLimit	%RPD	RPDLimit	Qual
Iron, Ferrous	0.0888	0.100	0.1000	0	88.8	85	115			N

Sample ID: LCSD-91002	Batch ID: 91002	TestNo: M3500-Fe D	Units: mg/L
SampType: LCSD	Run ID: UV/VIS_2_190520A	Analysis Date: 5/20/2019 3:53:00 PM	Prep Date: 5/20/2019

Analyte	Result	RL	SPK value	Ref Val	%REC	LowLimit	HighLimit	%RPD	RPDLimit	Qual
Iron, Ferrous	0.0879	0.100	0.1000	0	87.9	85	115	1.05	15	N

Sample ID: 1905185-11AMS	Batch ID: 91002	TestNo: M3500-Fe D	Units: mg/L
SampType: MS	Run ID: UV/VIS_2_190520A	Analysis Date: 5/20/2019 4:03:00 PM	Prep Date: 5/20/2019

Analyte	Result	RL	SPK value	Ref Val	%REC	LowLimit	HighLimit	%RPD	RPDLimit	Qual
Iron, Ferrous	0.0860	0.100	0.1000	0	86.0	85	115			N

Sample ID: 1905185-11AMSD	Batch ID: 91002	TestNo: M3500-Fe D	Units: mg/L
SampType: MSD	Run ID: UV/VIS_2_190520A	Analysis Date: 5/20/2019 4:03:00 PM	Prep Date: 5/20/2019

Analyte	Result	RL	SPK value	Ref Val	%REC	LowLimit	HighLimit	%RPD	RPDLimit	Qual
Iron, Ferrous	0.0861	0.100	0.1000	0	86.1	85	115	0.116	15	N

Qualifiers: B Analyte detected in the associated Method Blank J Analyte detected between MDL and RL ND Not Detected at the Method Detection Limit RL Reporting Limit J Analyte detected between SDL and RL	DF Dilution Factor MDL Method Detection Limit R RPD outside accepted control limits S Spike Recovery outside control limits N Parameter not NELAP certified
--	---

CLIENT: Golder
Work Order: 1905168
Project: Luminant-MLSES Ash Ponds

ANALYTICAL QC SUMMARY REPORT

RunID: UV/VIS_2_190520A

Sample ID ICV-190520	Batch ID: R104177	TestNo: M3500-Fe D	Units: mg/L							
SampType: ICV	Run ID: UV/VIS_2_190520A	Analysis Date: 5/20/2019 3:52:00 PM	Prep Date:							
Analyte	Result	RL	SPK value	Ref Val	%REC	LowLimit	HighLimit	%RPD	RPDLimit	Qual
Iron, Ferrous	0.0875	0.100	0.1000	0	87.5	85	115			N

Sample ID CCV1-190520	Batch ID: R104177	TestNo: M3500-Fe D	Units: mg/L							
SampType: CCV	Run ID: UV/VIS_2_190520A	Analysis Date: 5/20/2019 3:59:00 PM	Prep Date:							
Analyte	Result	RL	SPK value	Ref Val	%REC	LowLimit	HighLimit	%RPD	RPDLimit	Qual
Iron, Ferrous	0.197	0.100	0.2000	0	98.4	85	115			N

Sample ID CCV2-190520	Batch ID: R104177	TestNo: M3500-Fe D	Units: mg/L							
SampType: CCV	Run ID: UV/VIS_2_190520A	Analysis Date: 5/20/2019 4:12:00 PM	Prep Date:							
Analyte	Result	RL	SPK value	Ref Val	%REC	LowLimit	HighLimit	%RPD	RPDLimit	Qual
Iron, Ferrous	0.183	0.100	0.2000	0	91.7	85	115			N

LUMINANT

Qualifiers: B Analyte detected in the associated Method Blank J Analyte detected between MDL and RL ND Not Detected at the Method Detection Limit RL Reporting Limit J Analyte detected between SDL and RL	DF Dilution Factor MDL Method Detection Limit R RPD outside accepted control limits S Spike Recovery outside control limits N Parameter not NELAP certified
--	---

CLIENT: Golder
Work Order: 1905168
Project: Luminant-MLSES Ash Ponds

ANALYTICAL QC SUMMARY REPORT

RunID: WC_190517D

The QC data in batch 90953 applies to the following samples: 1905168-01C, 1905168-02C, 1905168-03C, 1905168-04C, 1905168-05C, 1905168-06C, 1905168-07C

Sample ID MB-90953	Batch ID: 90953	TestNo: M2540C	Units: mg/L							
SampType: MBLK	Run ID: WC_190517D	Analysis Date: 5/17/2019 11:40:00 AM	Prep Date: 5/16/2019							
Analyte	Result	RL	SPK value	Ref Val	%REC	LowLimit	HighLimit	%RPD	RPDLimit	Qual
Total Dissolved Solids (Residue, Filtera										
	<10.0	10.0								

Sample ID LCS-90953	Batch ID: 90953	TestNo: M2540C	Units: mg/L							
SampType: LCS	Run ID: WC_190517D	Analysis Date: 5/17/2019 11:40:00 AM	Prep Date: 5/16/2019							
Analyte	Result	RL	SPK value	Ref Val	%REC	LowLimit	HighLimit	%RPD	RPDLimit	Qual
Total Dissolved Solids (Residue, Filtera										
	745	10.0	745.6	0	99.9	90	113			

Sample ID 1905167-02C-DUP	Batch ID: 90953	TestNo: M2540C	Units: mg/L							
SampType: DUP	Run ID: WC_190517D	Analysis Date: 5/17/2019 11:40:00 AM	Prep Date: 5/16/2019							
Analyte	Result	RL	SPK value	Ref Val	%REC	LowLimit	HighLimit	%RPD	RPDLimit	Qual
Total Dissolved Solids (Residue, Filtera										
	5340	50.0	0	5375				0.747	5	

Sample ID 1905168-02C-DUP	Batch ID: 90953	TestNo: M2540C	Units: mg/L							
SampType: DUP	Run ID: WC_190517D	Analysis Date: 5/17/2019 11:40:00 AM	Prep Date: 5/16/2019							
Analyte	Result	RL	SPK value	Ref Val	%REC	LowLimit	HighLimit	%RPD	RPDLimit	Qual
Total Dissolved Solids (Residue, Filtera										
	940	50.0	0	910.0				3.24	5	

- | | | |
|--------------------|---|---|
| Qualifiers: | B Analyte detected in the associated Method Blank | DF Dilution Factor |
| | J Analyte detected between MDL and RL | MDL Method Detection Limit |
| | ND Not Detected at the Method Detection Limit | R RPD outside accepted control limits |
| | RL Reporting Limit | S Spike Recovery outside control limits |
| | J Analyte detected between SDL and RL | N Parameter not NELAP certified |

ANALYTICAL REPORT

June 10, 2019



²Tc

³Ss

⁴Cn

⁵Sr

⁶Qc

⁷Gl

⁸Al

⁹Sc

DHL Analytical, Inc.

Sample Delivery Group: L1100989
Samples Received: 05/21/2019
Project Number: 1905168
Description:

Report To: John DuPont
2300 Double Creek Drive
Round Rock, TX 78664

Entire Report Reviewed By:

Donna Eidson
Project Manager

Results relate only to the items tested or calibrated and are reported as rounded values. This test report shall not be reproduced, except in full, without written approval of the laboratory. Where applicable, sampling conducted by Pace National is performed per guidance provided in laboratory standard operating procedures: 060302, 060303, and 060304.

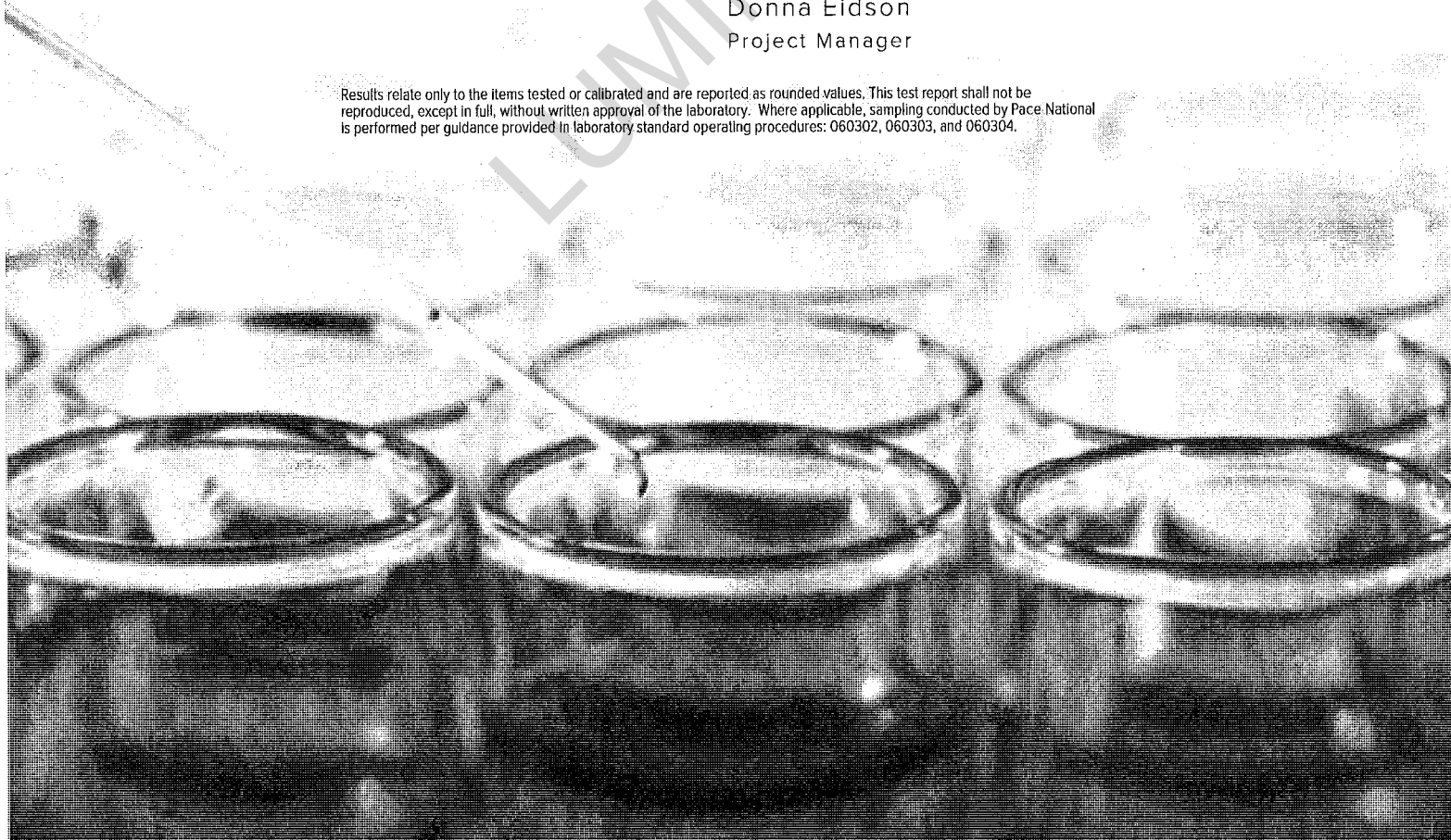











TABLE OF CONTENTS

ONE LAB. NATIONWIDE.



Cp: Cover Page	1	
Tc: Table of Contents	2	
Ss: Sample Summary	3	
Cn: Case Narrative	5	
Sr: Sample Results	6	
H-31 L1100989-01	6	
H-32 L1100989-02	7	
H-27 L1100989-03	8	
H-29 L1100989-04	9	
H-28 L1100989-05	10	
H-26 L1100989-06	11	
H-33 L1100989-07	12	
Qc: Quality Control Summary	13	
Radiochemistry by Method 904	13	
Radiochemistry by Method SM7500Ra B M	14	
Gl: Glossary of Terms	15	
Al: Accreditations & Locations	16	
Sc: Sample Chain of Custody	17	

LUMINANT

SAMPLE SUMMARY

ONE LAB. NATIONWIDE.

H-31 L1100989-01 Non-Potable Water

Collected by
05/14/19 07:40 Received date/time
05/21/19 10:10

Method	Batch	Dilution	Preparation date/time	Analysis date/time	Analyst	Location
Radiochemistry by Method 904	WG1285651	1	05/24/19 09:05	05/31/19 11:10	JMR	Mt. Juliet, TN
Radiochemistry by Method Calculation	WG1287234	1	05/29/19 08:27	06/03/19 17:48	RGT	Mt. Juliet, TN
Radiochemistry by Method SM7500Ra B M	WG1287234	1	05/29/19 08:27	06/03/19 17:48	RGT	Mt. Juliet, TN

H-32 L1100989-02 Non-Potable Water

Collected by
05/14/19 08:25 Received date/time
05/21/19 10:10

Method	Batch	Dilution	Preparation date/time	Analysis date/time	Analyst	Location
Radiochemistry by Method 904	WG1285651	1	05/24/19 09:05	05/31/19 11:10	JMR	Mt. Juliet, TN
Radiochemistry by Method Calculation	WG1287234	1	05/29/19 08:27	06/03/19 17:48	RGT	Mt. Juliet, TN
Radiochemistry by Method SM7500Ra B M	WG1287234	1	05/29/19 08:27	06/03/19 17:48	RGT	Mt. Juliet, TN

H-27 L1100989-03 Non-Potable Water

Collected by
05/14/19 09:40 Received date/time
05/21/19 10:10

Method	Batch	Dilution	Preparation date/time	Analysis date/time	Analyst	Location
Radiochemistry by Method 904	WG1285651	1	05/24/19 09:05	05/31/19 11:10	JMR	Mt. Juliet, TN
Radiochemistry by Method Calculation	WG1287234	1	05/29/19 08:27	06/03/19 17:48	RGT	Mt. Juliet, TN
Radiochemistry by Method SM7500Ra B M	WG1287234	1	05/29/19 08:27	06/03/19 17:48	RGT	Mt. Juliet, TN

H-29 L1100989-04 Non-Potable Water

Collected by
05/14/19 11:25 Received date/time
05/21/19 10:10

Method	Batch	Dilution	Preparation date/time	Analysis date/time	Analyst	Location
Radiochemistry by Method 904	WG1285651	1	05/24/19 09:05	05/31/19 11:10	JMR	Mt. Juliet, TN
Radiochemistry by Method Calculation	WG1287234	1	05/29/19 08:27	06/03/19 17:48	RGT	Mt. Juliet, TN
Radiochemistry by Method SM7500Ra B M	WG1287234	1	05/29/19 08:27	06/03/19 17:48	RGT	Mt. Juliet, TN

H-28 L1100989-05 Non-Potable Water

Collected by
05/14/19 12:30 Received date/time
05/21/19 10:10

Method	Batch	Dilution	Preparation date/time	Analysis date/time	Analyst	Location
Radiochemistry by Method 904	WG1285651	1	05/24/19 09:05	05/31/19 11:10	JMR	Mt. Juliet, TN
Radiochemistry by Method Calculation	WG1287234	1	05/29/19 08:27	06/03/19 17:48	RGT	Mt. Juliet, TN
Radiochemistry by Method SM7500Ra B M	WG1287234	1	05/29/19 08:27	06/03/19 17:48	RGT	Mt. Juliet, TN

H-26 L1100989-06 Non-Potable Water

Collected by
05/14/19 14:25 Received date/time
05/21/19 10:10

Method	Batch	Dilution	Preparation date/time	Analysis date/time	Analyst	Location
Radiochemistry by Method 904	WG1285651	1	05/24/19 09:05	05/31/19 11:10	JMR	Mt. Juliet, TN
Radiochemistry by Method Calculation	WG1287234	1	05/29/19 08:27	06/03/19 17:48	RGT	Mt. Juliet, TN
Radiochemistry by Method SM7500Ra B M	WG1287234	1	05/29/19 08:27	06/03/19 17:48	RGT	Mt. Juliet, TN

- 1 Cp
- 2 Tc
- 3 Ss
- 4 Cn
- 5 Sr
- 6 Qc
- 7 Gl
- 8 Al
- 9 Sc

SAMPLE SUMMARY

ONE LAB. NATIONWIDE. 

H-33 L1100989-07 Non-Potable Water

Collected by: _____ Collected date/time: 05/14/19 15:30 Received date/time: 05/21/19 10:10

Method	Batch	Dilution	Preparation date/time	Analysis date/time	Analyst	Location
Radiochemistry by Method 904	WG1285651	1	05/24/19 09:05	05/31/19 11:10	JMR	Mt. Juliet, TN
Radiochemistry by Method Calculation	WG1287234	1	05/29/19 08:27	06/03/19 17:48	RGT	Mt. Juliet, TN
Radiochemistry by Method SM7500Ra B M	WG1287234	1	05/29/19 08:27	06/03/19 17:48	RGT	Mt. Juliet, TN

- 1 Cp
- 2 Tc
- 3 Ss
- 4 Cn
- 5 Sr
- 6 Qc
- 7 Gl
- 8 Al
- 9 Sc

LUMINANT



All sample aliquots were received at the correct temperature, in the proper containers, with the appropriate preservatives, and within method specified holding times, unless qualified or notated within the report. Where applicable, all MDL (LOD) and RDL (LOQ) values reported for environmental samples have been corrected for the dilution factor used in the analysis. All radiochemical sample results for solids are reported on a dry weight basis with the exception of tritium, carbon-14 and radon, unless wet weight was requested by the client. All Method and Batch Quality Control are within established criteria except where addressed in this case narrative, a non-conformance form or properly qualified within the sample results. By my digital signature below, I affirm to the best of my knowledge, all problems/anomalies observed by the laboratory as having the potential to affect the quality of the data have been identified by the laboratory, and no information or data have been knowingly withheld that would affect the quality of the data.

Donna Eidson
Project Manager

- 1 Cp
- 2 Tc
- 3 Ss
- 4 Cn
- 5 Sr
- 6 Qc
- 7 Gl
- 8 Al
- 9 Sc

LUMINANT

Radiochemistry by Method 904

Analyte	Result	Qualifier	Uncertainty	MDA	Analysis Date	Batch
	pCi/l		+ / -	pCi/l	date / time	
RADIUM-228	0.531		0.515	0.789	05/31/2019 11:10	WG1285651
(T) Barium	120			62.0-143	05/31/2019 11:10	WG1285651
(T) Yttrium	93.0			79.0-136	05/31/2019 11:10	WG1285651

- 1 Cp
- 2 Tc
- 3 Ss
- 4 Cn
- 5 Sr
- 6 Qc
- 7 Gl
- 8 Al
- 9 Sc

Radiochemistry by Method Calculation

Analyte	Result	Qualifier	Uncertainty	MDA	Analysis Date	Batch
	pCi/l		+ / -	pCi/l	date / time	
Combined Radium	3.15		1.09	0.978	06/03/2019 17:48	WG1287234

Radiochemistry by Method SM7500Ra B M

Analyte	Result	Qualifier	Uncertainty	MDA	Analysis Date	Batch
	pCi/l		+ / -	pCi/l	date / time	
RADIUM-226	2.62		0.578	0.189	06/03/2019 17:48	WG1287234
(T) Barium-133	104			30.0-143	06/03/2019 17:48	WG1287234

LUMINANT



Collected date/time: 05/14/19 08:25

L1100989

Radiochemistry by Method 904

Analyte	Result	Qualifier	Uncertainty	MDA	Analysis Date	Batch
	pCi/l		+ / -	pCi/l	date / time	
RADIUM-228	0.147		0.380	0.546	05/31/2019 11:10	WG1285651
(T) Barium	100			62.0-143	05/31/2019 11:10	WG1285651
(T) Yttrium	109			79.0-136	05/31/2019 11:10	WG1285651



Radiochemistry by Method Calculation

Analyte	Result	Qualifier	Uncertainty	MDA	Analysis Date	Batch
	pCi/l		+ / -	pCi/l	date / time	
Combined Radium	0.450		0.625	0.833	06/03/2019 17:48	WG1287234



Radiochemistry by Method SM7500Ra B M

Analyte	Result	Qualifier	Uncertainty	MDA	Analysis Date	Batch
	pCi/l		+ / -	pCi/l	date / time	
RADIUM-226	0.303		0.245	0.287	06/03/2019 17:48	WG1287234
(T) Barium-133	105			30.0-143	06/03/2019 17:48	WG1287234



LUMINANT



Radiochemistry by Method 904

Analyte	Result	Qualifier	Uncertainty	MDA	Analysis Date	Batch
	pCi/l		+ / -	pCi/l	date / time	
RADIUM-228	0.928		0.365	0.563	05/31/2019 11:10	WG1285651
(T) Barium	96.7			62.0-143	05/31/2019 11:10	WG1285651
(T) Yttrium	98.1			79.0-136	05/31/2019 11:10	WG1285651

1 Cp

2 Tc

3 Ss

Radiochemistry by Method Calculation

Analyte	Result	Qualifier	Uncertainty	MDA	Analysis Date	Batch
	pCi/l		+ / -	pCi/l	date / time	
Combined Radium	2.03		0.814	0.854	06/03/2019 17:48	WG1287234

4 Cn

5 Sr

Radiochemistry by Method SM7500Ra B M

Analyte	Result	Qualifier	Uncertainty	MDA	Analysis Date	Batch
	pCi/l		+ / -	pCi/l	date / time	
RADIUM-226	1.10		0.449	0.291	06/03/2019 17:48	WG1287234
(T) Barium-133	85.4			30.0-143	06/03/2019 17:48	WG1287234

6 Qc

7 Gl

8 Al

9 Sc

LUMINANT



Radiochemistry by Method 904

Analyte	Result	Qualifier	Uncertainty	MDA	Analysis Date	Batch
	pCi/l		+ / -	pCi/l	date / time	
RADIUM-228	0.352		0.428	0.707	05/31/2019 11:10	WG1285651
(T) Barium	116			62.0-143	05/31/2019 11:10	WG1285651
(T) Yttrium	96.5			79.0-136	05/31/2019 11:10	WG1285651

1 Cp

2 Tc

3 Ss

Radiochemistry by Method Calculation

Analyte	Result	Qualifier	Uncertainty	MDA	Analysis Date	Batch
	pCi/l		+ / -	pCi/l	date / time	
Combined Radium	0.474		0.641	1.05	06/03/2019 17:48	WG1287234

4 Cn

5 Sr

Radiochemistry by Method SM7500Ra B M

Analyte	Result	Qualifier	Uncertainty	MDA	Analysis Date	Batch
	pCi/l		+ / -	pCi/l	date / time	
RADIUM-226	0.122		0.213	0.339	06/03/2019 17:48	WG1287234
(T) Barium-133	72.2			30.0-143	06/03/2019 17:48	WG1287234

6 Qc

7 Gl

8 Al

9 Sc

LUMINANT



Collected date/time: 05/14/19 12:30

L1100989

Radiochemistry by Method 904

Analyte	Result pCi/l	Qualifier	Uncertainty + / -	MDA pCi/l	Analysis Date date / time	Batch
RADIUM-228	0.615		0.370	0.575	05/31/2019 11:10	WG1285651
(T) Barium	106			62.0-143	05/31/2019 11:10	WG1285651
(T) Yttrium	95.5			79.0-136	05/31/2019 11:10	WG1285651

¹ Cp

² Tc

³ Ss

Radiochemistry by Method Calculation

Analyte	Result pCi/l	Qualifier	Uncertainty + / -	MDA pCi/l	Analysis Date date / time	Batch
Combined Radium	1.06		0.634	0.777	06/03/2019 17:48	WG1287234

⁴ Cn

⁵ Sr

Radiochemistry by Method SM7500Ra B M

Analyte	Result pCi/l	Qualifier	Uncertainty + / -	MDA pCi/l	Analysis Date date / time	Batch
RADIUM-226	0.444		0.264	0.202	06/03/2019 17:48	WG1287234
(T) Barium-133	90.7			30.0-143	06/03/2019 17:48	WG1287234

⁶ Qc

⁷ Gl

⁸ Al

⁹ Sc

LUMINANT



Collected date/time: 05/14/19 14:25

L1100989

Radiochemistry by Method 904

Analyte	Result	Qualifier	Uncertainty	MDA	Analysis Date	Batch
	pCi/l		+ / -	pCi/l	date / time	
RADIUM-228	0.598		0.330	0.545	05/31/2019 11:10	WG1285651
(T) Borium	98.4			62.0-143	05/31/2019 11:10	WG1285651
(T) Yttrium	113			79.0-136	05/31/2019 11:10	WG1285651

1 Cp

2 Tc

3 Ss

Radiochemistry by Method Calculation

Analyte	Result	Qualifier	Uncertainty	MDA	Analysis Date	Batch
	pCi/l		+ / -	pCi/l	date / time	
Combined Radium	2.03		0.761	0.783	06/03/2019 17:48	WG1287234

4 Cn

5 Sr

Radiochemistry by Method SM7500Ra B M

Analyte	Result	Qualifier	Uncertainty	MDA	Analysis Date	Batch
	pCi/l		+ / -	pCi/l	date / time	
RADIUM-226	1.43		0.431	0.238	06/03/2019 17:48	WG1287234
(T) Barium-133	103			30.0-143	06/03/2019 17:48	WG1287234

6 Qc

7 Gl

8 Al

9 Sc

LUMINANT



Radiochemistry by Method 904

Analyte	Result	Qualifier	Uncertainty	MDA	Analysis Date	Batch
	pCi/l		+ / -	pCi/l	date / time	
RADIUM-228	1.35		0.414	0.627	05/31/2019 11:10	WG1285651
(T) Barium	97.4			62.0-143	05/31/2019 11:10	WG1285651
(T) Yttrium	96.3			79.0-136	05/31/2019 11:10	WG1285651

1 Cp

2 Tc

3 Ss

Radiochemistry by Method Calculation

Analyte	Result	Qualifier	Uncertainty	MDA	Analysis Date	Batch
	pCi/l		+ / -	pCi/l	date / time	
Combined Radium	2.20		0.764	0.846	06/03/2019 17:48	WG1287234

4 Cn

5 Sr

Radiochemistry by Method SM7500Ra B M

Analyte	Result	Qualifier	Uncertainty	MDA	Analysis Date	Batch
	pCi/l		+ / -	pCi/l	date / time	
RADIUM-226	0.850		0.350	0.219	06/03/2019 17:48	WG1287234
(T) Barium-133	102			30.0-143	06/03/2019 17:48	WG1287234

6 Qc

7 Gl

8 Al

9 Sc

LUMINANT

Method Blank (MB)

(MB) R3417363-1 05/30/19 12:10

Analyte	MB Result pCi/l	MB Qualifier	MB MDA pCi/l
Radium-228	-0.0581		0.396
(T) Barium	105		
(T) Yttrium	110		

L1100977-01 Original Sample (OS) • Duplicate (DUP)

(OS) L1100977-01 05/30/19 12:10 • (DUP) R3417363-5 05/30/19 12:10

Analyte	Original Result pCi/l	DUP Result pCi/l	Dilution	DUP RPD %	DUP RER	DUP Qualifier	DUP RPD Limits %	DUP RER Limit
Radium-228	-0.0695	0.650	1	200	0.741		20	3
(T) Barium	109	111						
(T) Yttrium	113	107						

Laboratory Control Sample (LCS)

(LCS) R3417363-2 05/30/19 12:10

Analyte	Spike Amount pCi/l	LCS Result pCi/l	LCS Rec. %	Rec. Limits %	LCS Qualifier
Radium-228	5.00	5.29	106	80.0-120	
(T) Barium			104		
(T) Yttrium			114		

L1100989-01 Original Sample (OS) • Matrix Spike (MS) • Matrix Spike Duplicate (MSD)

(OS) L1100989-01 05/31/19 11:10 • (MS) R3417363-3 05/30/19 12:10 • (MSD) R3417363-4 05/30/19 12:10

Analyte	Spike Amount pCi/l	Original Result pCi/l	MS Result pCi/l	MSD Result pCi/l	MS Rec. %	MSD Rec. %	Dilution	Rec. Limits %	MS Qualifier	MSD Qualifier	RPD %	MS RER	RPD Limits %
Radium-228	20.0	0.531	20.9	19.5	102	94.8	1	70.0-130			7.08		20
(T) Barium		120	102	115									
(T) Yttrium		93.0	117	114									

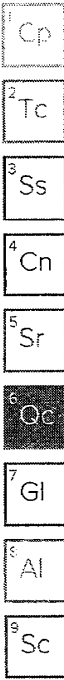



Radiochemistry by Method SM7500Ra B M

L1100989-01,02,03,04,05,06,07

Method Blank (MB)

(MB) R3419580-1 06/03/19 17:43

Analyte	MB Result pCi/l	MB Qualifier	MB MDA pCi/l
Radium-226	0.00994		0.0573
(T) Barium-133	67.4		

L1103100-01 Original Sample (OS) • Duplicate (DUP)

(OS) L1103100-01 06/03/19 17:43 • (DUP) R3419580-7 06/03/19 17:43

Analyte	Original Result pCi/l	DUP Result pCi/l	Dilution	DUP RPD %	DUP RER	DUP Qualifier	DUP RPD Limits %	DUP RER Limit
Radium-226	0.267	1.33	1	133	2.21		20	3
(T) Barium-133	110	102						

Laboratory Control Sample (LCS)

(LCS) R3419580-2 06/03/19 17:43

Analyte	Spike Amount pCi/l	LCS Result pCi/l	LCS Rec. %	Rec. Limits %	LCS Qualifier
Radium-226	5.02	5.10	102	80.0-120	
(T) Barium-133			56.0		

L1101875-03 Original Sample (OS) • Matrix Spike (MS) • Matrix Spike Duplicate (MSD)

(OS) L1101875-03 06/03/19 17:43 • (MS) R3419580-3 06/03/19 17:43 • (MSD) R3419580-6 06/03/19 17:43

Analyte	Spike Amount pCi/l	Original Result pCi/l	MS Result pCi/l	MSD Result pCi/l	MS Rec. %	MSD Rec. %	Dilution	Rec. Limits %	MS Qualifier	MSD Qualifier	RPD %	MS RER	RPD Limits %
Radium-226	20.1	0.637	17.9	20.3	86.0	97.8	1	75.0-125			12.4		20
(T) Barium-133		83.3			53.7	71.3							

L1101881-03 Original Sample (OS) • Matrix Spike (MS) • Matrix Spike Duplicate (MSD)

(OS) L1101881-03 06/03/19 17:43 • (MS) R3419580-4 06/03/19 17:43 • (MSD) R3419580-5 06/03/19 17:43

Analyte	Spike Amount pCi/l	Original Result pCi/l	MS Result pCi/l	MSD Result pCi/l	MS Rec. %	MSD Rec. %	Dilution	Rec. Limits %	MS Qualifier	MSD Qualifier	RPD %	MS RER	RPD Limits %
Radium-226	20.1	0.522	21.1	19.2	102	93.1	1	75.0-125			9.23		20
(T) Barium-133		105			89.6	99.7							

- 1 Cp
- 2 Tc
- 3 Ss
- 4 Cn
- 5 Sr
- 6 Qc
- 7 Gl
- 8 Al
- 9 Sc



Guide to Reading and Understanding Your Laboratory Report

The information below is designed to better explain the various terms used in your report of analytical results from the Laboratory. This is not intended as a comprehensive explanation, and if you have additional questions please contact your project representative.

Abbreviations and Definitions

MDA	Minimum Detectable Activity.
Rec.	Recovery.
RER	Replicate Error Ratio.
RPD	Relative Percent Difference.
SDG	Sample Delivery Group.
(T)	Tracer - A radioisotope of known concentration added to a solution of chemically equivalent radioisotopes at a known concentration to assist in monitoring the yield of the chemical separation.
Analyte	The name of the particular compound or analysis performed. Some Analyses and Methods will have multiple analytes reported.
Dilution	If the sample matrix contains an interfering material, the sample preparation volume or weight values differ from the standard, or if concentrations of analytes in the sample are higher than the highest limit of concentration that the laboratory can accurately report, the sample may be diluted for analysis. If a value different than 1 is used in this field, the result reported has already been corrected for this factor.
Limits	These are the target % recovery ranges or % difference value that the laboratory has historically determined as normal for the method and analyte being reported. Successful QC Sample analysis will target all analytes recovered or duplicated within these ranges.
Original Sample	The non-spiked sample in the prep batch used to determine the Relative Percent Difference (RPD) from a quality control sample. The Original Sample may not be included within the reported SDG.
Qualifier	This column provides a letter and/or number designation that corresponds to additional information concerning the result reported. If a Qualifier is present, a definition per Qualifier is provided within the Glossary and Definitions page and potentially a discussion of possible implications of the Qualifier in the Case Narrative if applicable.
Result	The actual analytical final result (corrected for any sample specific characteristics) reported for your sample. If there was no measurable result returned for a specific analyte, the result in this column may state "ND" (Not Detected) or "BDL" (Below Detectable Levels). The information in the results column should always be accompanied by either an MDL (Method Detection Limit) or RDL (Reporting Detection Limit) that defines the lowest value that the laboratory could detect or report for this analyte.
Uncertainty (Radiochemistry)	Confidence level of 2 sigma.
Case Narrative (Cn)	A brief discussion about the included sample results, including a discussion of any non-conformances to protocol observed either at sample receipt by the laboratory from the field or during the analytical process. If present, there will be a section in the Case Narrative to discuss the meaning of any data qualifiers used in the report.
Quality Control Summary (Qc)	This section of the report includes the results of the laboratory quality control analyses required by procedure or analytical methods to assist in evaluating the validity of the results reported for your samples. These analyses are not being performed on your samples typically, but on laboratory generated material.
Sample Chain of Custody (Sc)	This is the document created in the field when your samples were initially collected. This is used to verify the time and date of collection, the person collecting the samples, and the analyses that the laboratory is requested to perform. This chain of custody also documents all persons (excluding commercial shippers) that have had control or possession of the samples from the time of collection until delivery to the laboratory for analysis.
Sample Results (Sr)	This section of your report will provide the results of all testing performed on your samples. These results are provided by sample ID and are separated by the analyses performed on each sample. The header line of each analysis section for each sample will provide the name and method number for the analysis reported.
Sample Summary (Ss)	This section of the Analytical Report defines the specific analyses performed for each sample ID, including the dates and times of preparation and/or analysis.

- 1 Cp
- 2 Tc
- 3 Ss
- 4 Cn
- 5 Sr
- 6 Qc
- 7 Gl
- 8 Ai
- 9 Sc

Qualifier Description

The remainder of this page intentionally left blank, there are no qualifiers applied to this SDG.

ACCREDITATIONS & LOCATIONS

ONE LAB. NATIONWIDE.



Pace National is the only environmental laboratory accredited/certified to support your work nationwide from one location. One phone call, one point of contact, one laboratory. No other lab is as accessible or prepared to handle your needs throughout the country. Our capacity and capability from our single location laboratory is comparable to the collective totals of the network laboratories in our industry. The most significant benefit to our one location design is the design of our laboratory campus. The model is conducive to accelerated productivity, decreasing turn-around time, and preventing cross contamination, thus protecting sample integrity. Our focus on premium quality and prompt service allows us to be YOUR LAB OF CHOICE.

* Not all certifications held by the laboratory are applicable to the results reported in the attached report.
 * Accreditation is only applicable to the test methods specified on each scope of accreditation held by Pace National.

State Accreditations

Alabama	40660	Nebraska	NE-OS-15-05
Alaska	17-026	Nevada	TN-03-2002-34
Arizona	AZ0612	New Hampshire	2975
Arkansas	88-0469	New Jersey-NELAP	TN002
California	2932	New Mexico ¹	n/a
Colorado	TN00003	New York	11742
Connecticut	PH-0197	North Carolina	Env375
Florida	E87487	North Carolina ¹	DW21704
Georgia	NELAP	North Carolina ³	41
Georgia ¹	923	North Dakota	R-140
Idaho	TN00003	Ohio-VAP	CL0069
Illinois	200008	Oklahoma	9915
Indiana	C-TN-01	Oregon	TN200002
Iowa	364	Pennsylvania	68-02979
Kansas	E-10277	Rhode Island	LA000356
Kentucky ^{1,6}	90010	South Carolina	84004
Kentucky ²	16	South Dakota	n/a
Louisiana	AI30792	Tennessee ^{1,4}	2006
Louisiana ¹	LA180010	Texas	T104704245-18-15
Maine	TN0002	Texas ⁵	LAB0152
Maryland	324	Utah	TN00003
Massachusetts	M-TN003	Vermont	VT2006
Michigan	9958	Virginia	460132
Minnesota	047-999-395	Washington	C847
Mississippi	TN00003	West Virginia	233
Missouri	340	Wisconsin	9980939910
Montana	CERT0086	Wyoming	A2LA

Third Party Federal Accreditations

A2LA - ISO 17025	1461.01	AIHA-LAP, LLC EMLAP	100789
A2LA - ISO 17025 ²	1461.02	DOD	1461.01
Canada	1461.01	USDA	P330-15-00234
EPA-Crypto	TN00003		

¹ Drinking Water ² Underground Storage Tanks ³ Aquatic Toxicity ⁴ Chemical/Microbiological ⁵ Mold ⁶ Wastewater n/a Accreditation not applicable

Our Locations

Pace National has sixty-four client support centers that provide sample pickup and/or the delivery of sampling supplies. If you would like assistance from one of our support offices, please contact our main office. Pace National performs all testing at our central laboratory.

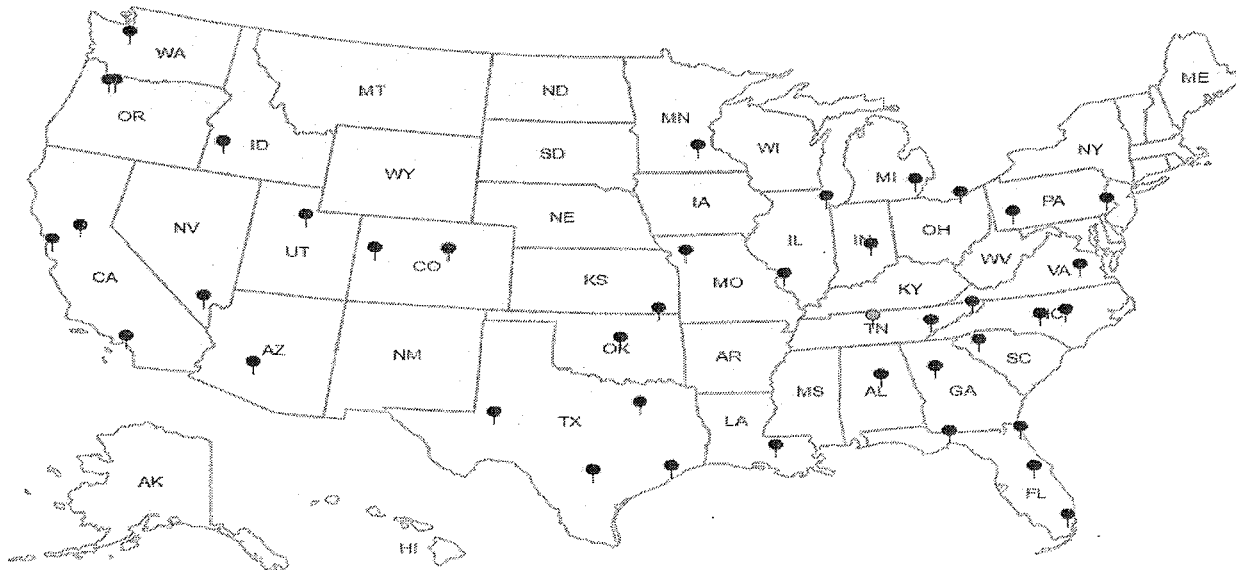

- 1 Cp
- 2 Tc
- 3 Ss
- 4 Cn
- 5 Sr
- 6 Qc
- 7 Gl
- AI
- 9 Sc

**Pace Analytical National Center for Testing & Innovation
Cooler Receipt Form**

Client: <i>DHLRRTX</i>	SDG#: <i>1100989</i>		
Cooler Received/Opened On: <i>5/21/19</i>	Temperature: <i>Amb</i>		
Received By: Brock Fariss			
Signature: <i>[Signature]</i>			
Receipt Check List	NP	Yes	No
COC Seal Present / Intact?	/		
COC Signed / Accurate?		/	
Bottles arrive intact?		/	
Correct bottles used?		/	
Sufficient volume sent?			
If Applicable			
VOA Zero headspace?		/	
Preservation Correct / Checked?			



Login #: L1100989	Client: DHLRRTX	Date: 05/21	Evaluated by: Kelsey S
-------------------	-----------------	-------------	------------------------

Non-Conformance (check applicable items)

Sample Integrity	Chain of Custody Clarification	
Parameter(s) past holding time	Login Clarification Needed	If Broken Container:
Temperature not in range	Chain of custody is incomplete	Insufficient packing material around container
Improper container type	Please specify Metals requested.	Insufficient packing material inside cooler
x pH not in range.	Please specify TCLP requested.	Improper handling by carrier (FedEx / UPS / Courier)
Insufficient sample volume.	Received additional samples not listed on coc.	Sample was frozen
Sample is biphasic.	Sample ids on containers do not match ids on coc	Container lid not intact
Vials received with headspace.	Trip Blank not received.	If no Chain of Custody:
Broken container	Client did not "X" analysis.	Received by:
Broken container:	Chain of Custody is missing	Date/Time:
Sufficient sample remains		Temp./Cont. Rec./pH:
		Carrier:
		Tracking#

Login Comments: 1 of 2 H-32 was received with a pH of 6. pH adj in login 1511 5/21

Client informed by:	Call	Email	Voice Mail	Date:	Time:
TSR Initials:	Client Contact:				

Login Instructions:

Noted 5/21/19 1547

1100989

CHAIN-OF-CUSTODY RECORD

DHL Analytical, Inc.
2300 Double Creek Drive
Round Rock, TX 78664
TEL: (512) 388-8222
Work Order 1905168

FAX: (512) 388-8229

H007

Subcontractor:
Pace Analytical
12065 Lebanon Rd
Mt. Juliet, TN 37122

TEL: (615) 773-5923
FAX:
Acct #: DHLRRTX

15-May-19

Sample Id	Matrix	DHL#	Date Collected	Bottle Type	Requested Tests				
					Ra-228 E904.0	Ra-226 M7500 Ra B M			
H-31	Aqueous	-01D	05/14/19 07:40 AM	1LHDPEHNO3		1			01
H-31	Aqueous	-01E	05/14/19 07:40 AM	1LHDPEHNO3	1				1
H-32	Aqueous	-02D	05/14/19 08:25 AM	1LHDPEHNO3		1			02
H-32	Aqueous	-02E	05/14/19 08:25 AM	1LHDPEHNO3	1				1
H-27	Aqueous	-03D	05/14/19 09:40 AM	1LHDPEHNO3		1			03
H-27	Aqueous	-03E	05/14/19 09:40 AM	1LHDPEHNO3	1				1
H-29	Aqueous	-04D	05/14/19 11:25 AM	1LHDPEHNO3		1			04
H-29	Aqueous	-04E	05/14/19 11:25 AM	1LHDPEHNO3	1				1
H-28	Aqueous	-05D	05/14/19 12:30 PM	1LHDPEHNO3		1			05
H-28	Aqueous	-05E	05/14/19 12:30 PM	1LHDPEHNO3	1				1
H-26	Aqueous	-06D	05/14/19 02:25 PM	1LHDPEHNO3		1			06
H-26	Aqueous	-06E	05/14/19 02:25 PM	1LHDPEHNO3	1				1
H-33	Aqueous	-07D	05/14/19 03:30 PM	1LHDPEHNO3		1			07
H-33	Aqueous	-07E	05/14/19 03:30 PM	1LHDPEHNO3	1				1

General Comments:

Please analyze these samples with Normal Turnaround Time.
Report RA-225, Ra-228 & Combined per Specs
Quality Control Package Needed: Standard - NELAC Rad Test compliant
Email to cac@dhlanalytical.com & dupont@dhlanalytical.com

UPS
REC-114

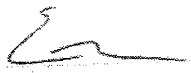
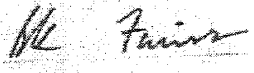
Relinquished by: 	Date/Time: 5/17/19 17:00	Received by: 	Date/Time: 5/21/19 10:10
Relinquished by:		Received by:	

PH adj @ 1511
RAD SCREEN < 0.5 mR/h
AmV



May 30, 2019

Will Vienne
Golder
2201 Double Creek Dr #4004
Round Rock, Texas 78664
TEL: (512) 671-3434
FAX (512) 671-3446
RE: Luminant-MLSES Ash Ponds

Order No.: 1905167

Dear Will Vienne:

DHL Analytical, Inc. received 2 sample(s) on 5/15/2019 for the analyses presented in the following report.

There were no problems with the analyses and all data met requirements of NELAP except where noted in the Case Narrative. All non-NELAP methods will be identified accordingly in the case narrative and all estimated uncertainties of test results are within method or EPA specifications.

If you have any questions regarding these tests results, please feel free to call. Thank you for using DHL Analytical.

Sincerely,

A handwritten signature in black ink, appearing to read 'John DuPont', written over a large, light grey watermark that says 'LUMINANT' diagonally across the page.

John DuPont
General Manager

This report was performed under the accreditation of the State of Texas Laboratory Certification Number: T104704211-19-24



Table of Contents

Miscellaneous Documents	3
CaseNarrative 1905167	7
WorkOrderSampleSummary 1905167	9
PrepDatesReport 1905167	10
AnalyticalDatesReport 1905167	11
Analytical Report 1905167	12
AnalyticalQCSummaryReport 1905167	16
Subcontract Report 1905167	40

LUMINANT



2300 Double Creek Dr. ■ Round Rock, TX 78664
 Phone (512) 388-8222 ■ FAX (512) 388-8229
 Web: www.dhlanalytical.com
 E-Mail: login@dhlanalytical.com



No 86480

CHAIN-OF-CUSTODY

CLIENT: **GOLDER**
 ADDRESS: **2201 DOUBLE CREEK DR, ROUND ROCK, TX 78664**
 PHONE: **512-671-3434** FAX/E-MAIL: **512-671-3446**
 DATA REPORTED TO: **WILL VIENNE**
 ADDITIONAL REPORT COPIES TO:

DATE: **5-14-19** PAGE **1** OF **1**
 PO #: _____ DHL WORK ORDER #: **1905167**
 PROJECT LOCATION OR NAME: **LUMINANT - MUSES ASH PONDS**
 CLIENT PROJECT #: **19122262-C** COLLECTOR: **J. BRATTON**

Authorize 5% surcharge for TRRP Report? <input type="checkbox"/> Yes <input type="checkbox"/> No		S=SOIL P=PAINT W=WATER SL=SLUDGE A=AIR O=OTHER L=LIQUID SO=SOLID SE=SEDIMENT		PRESERVATION # of Containers HCl <input type="checkbox"/> HNO ₃ <input type="checkbox"/> H ₂ SO ₄ <input type="checkbox"/> NaOH <input type="checkbox"/> ICE <input type="checkbox"/> UNPRESERVED <input type="checkbox"/>	ANALYSES BTEX <input type="checkbox"/> MTBE <input type="checkbox"/> [METHOD 8021] TPH 1005 <input type="checkbox"/> TPH 1006 <input type="checkbox"/> HOLD 1006 <input type="checkbox"/> GRO [METHOD 80151] <input type="checkbox"/> DRO [METHOD 81051] <input type="checkbox"/> VOC 8260 <input type="checkbox"/> VOC 624 <input type="checkbox"/> VOC 8260/5035 <input type="checkbox"/> SVOC 8270 [PAH 8270] <input type="checkbox"/> HOLD PAH <input type="checkbox"/> SVOC 625 <input type="checkbox"/> 8270 PEST <input type="checkbox"/> 625 PEST/PCB <input type="checkbox"/> 608 PCB <input type="checkbox"/> 8270 O-P PEST <input type="checkbox"/> 8082 PCB <input type="checkbox"/> 8270 PCB <input type="checkbox"/> 821 HERB <input type="checkbox"/> T PHOS. AMMONIA <input type="checkbox"/> METALS 8020 <input type="checkbox"/> METALS 2008 <input type="checkbox"/> DISS. METALS <input type="checkbox"/> PH <input type="checkbox"/> HEX CHROM <input type="checkbox"/> CALORIDE <input type="checkbox"/> TCLP-SVOC <input type="checkbox"/> ANIONS <input type="checkbox"/> RC1 <input type="checkbox"/> METALS <input type="checkbox"/> VOC <input type="checkbox"/> RC2 <input type="checkbox"/> FLASHPOINT <input type="checkbox"/> RCRA 8 <input type="checkbox"/> TDS <input type="checkbox"/> TSS <input type="checkbox"/> % MOISTURE <input type="checkbox"/> DISS. METALS <input type="checkbox"/> APPENDIX III <input type="checkbox"/> ALK. ND, PO ₄ , PH ₄ , NH ₄ , NO ₃ , K, FERROUS, & PERM. C. IRON				
Field Sample I.D.	DHL Lab #	Date	Time		Matrix	Container Type			

Field Sample I.D.	DHL Lab #	Date	Time	Matrix	Container Type	# of Containers	HCl	HNO ₃	H ₂ SO ₄	NaOH	ICE	UNPRESERVED	ANALYSES	FIELD NOTES
LAKE SAMPLE	01	5-14-19	1005	W		7	X							XXX
POND SAMPLE	02	5-14-19	1020	W		7	X							XXX

RELINQUISHED BY: (Signature) [Signature]	DATE/TIME 5-14-19 1800	RECEIVED BY: (Signature) FedEx
RELINQUISHED BY: (Signature) FedEx	DATE/TIME 5/15/19 0943	RECEIVED BY: (Signature) [Signature]
RELINQUISHED BY: (Signature)	DATE/TIME	RECEIVED BY: (Signature)

TURN AROUND TIME RUSH <input type="checkbox"/> CALL FIRST 1 DAY <input type="checkbox"/> CALL FIRST 2 DAY <input type="checkbox"/> NORMAL <input checked="" type="checkbox"/> OTHER <input type="checkbox"/>	LABORATORY USE ONLY: RECEIVING TEMP: 45°C THERM #: 78 CUSTODY SEALS: <input type="checkbox"/> BROKEN <input type="checkbox"/> INTACT <input checked="" type="checkbox"/> NOT USED CARRIER: <input type="checkbox"/> LONE STAR <input checked="" type="checkbox"/> FEDEX <input type="checkbox"/> UPS <input type="checkbox"/> OTHER <input type="checkbox"/> COURIER DELIVERY <input checked="" type="checkbox"/> HAND DELIVERED
--	--

Eric Lau

From: John DuPont
Sent: Tuesday, May 28, 2019 11:35 AM
To: Eric Lau
Subject: FW: CCR Analysis

Appendix III Parameters:

Metals (Ca and B)
Anions (Cl, F, and SO4)
TDS

Appendix IV Parameters:

Metals (As, Ba, Be, Cd, Co, Cr, Hg, Li, Mo, Pb, Sb, Se, and Tl)
Ra-226
Ra-228

From: Vienne, Will [mailto:William_Vienne@golder.com]
Sent: Tuesday, April 09, 2019 12:48 PM
To: John DuPont <dupont@dhlanalytical.com>
Subject: CCR Analysis

LUMINANT

ORIGIN ID:GGGA (512) 671-3434
J. BRAYTON
GOLDER
2201 DOUBLE CREEK DR
ROUND ROCK, TX 78664
UNITED STATES US

SHIP DATE: 14MAY19
ACTWGT: 50.90 LB
CAD: 006894166/SSFE2002
DIMS: 23x14x14 IN
BILL THIRD PARTY

Part # 156297, 436249917, 539510, 19

TO

DHL
2300 DOUBLE CREEK DR

ROUND ROCK TX 78664

(512) 888-8222

REF:

INU:
PO:

DEPT:

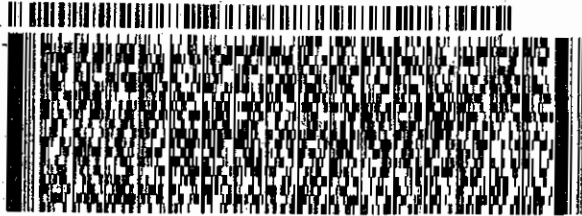

FedEx
Express



AM107010610161F

2 of 4

MPS# 7872 5506 5857
0263

Mstr# 7872 5506 5846

0201

WED - 15 MAY 10:30A
PRIORITY OVERNIGHT

A8 BSMA

78664
TX-US AUS



Sample Receipt Checklist

Client Name Golder

Date Received: 5/15/2019

Work Order Number 1905167

Received by EL

Checklist completed by: [Signature] 5/15/2019 Reviewed by: [Initials] 5/15/2019

Carrier name FedEx 1day

- Shipping container/cooler in good condition? Yes [x] No [] Not Present []
Custody seals intact on shipping container/cooler? Yes [] No [] Not Present [x]
Custody seals intact on sample bottles? Yes [] No [] Not Present [x]
Chain of custody present? Yes [x] No []
Chain of custody signed when relinquished and received? Yes [x] No []
Chain of custody agrees with sample labels? Yes [x] No []
Samples in proper container/bottle? Yes [x] No []
Sample containers intact? Yes [x] No []
Sufficient sample volume for indicated test? Yes [x] No []
All samples received within holding time? Yes [x] No []
Container/Temp Blank temperature in compliance? Yes [x] No [] 4.5 °C
Water - VOA vials have zero headspace? Yes [x] No [] No VOA vials submitted []
Water - pH<2 acceptable upon receipt? Yes [x] No [] NA [] LOT # 11837
Adjusted? No Checked by EL
Water - pH>9 (S) or pH>10 (CN) acceptable upon receipt? Yes [] No [] NA [x] LOT #
Adjusted? Checked by

Any No response must be detailed in the comments section below.

Client contacted Date contacted: Person contacted

Contacted by: Regarding:

Comments:

Corrective Action

CLIENT: Golder
Project: Luminant-MLSES Ash Ponds
Lab Order: 1905167

CASE NARRATIVE

Samples were analyzed using the methods outlined in the following references:

Method SW6020A - Metals Analysis
Method SW7470A - Mercury Analysis
Method E300 - Anions Analysis
Method M2320 B - Alkalinity Analysis
Method M3500-Fe D - Ferrous Iron Analysis (this parameter is not NELAP certified)
Method M3500-Fe D - Ferric Iron (calculation) (this calculation is not NELAP certified).
Method M4500-P E - Orthophosphate Analysis
Method M2540C - TDS Analysis
Sub-contract - Radium-228 and Radium-226 analyses by methods E904 and SM 7500 Ra B M.
Analyzed at Pace Analytical.

LOG IN

The samples were received and log-in performed on 5/15/19. A total of 2 samples were received. The samples arrived in good condition and were properly packaged.

METALS ANALYSIS

For Metals analysis performed on 5/21/19 the matrix spike and matrix spike duplicate recoveries were below control limits for Calcium and Sodium. These are flagged accordingly in the QC summary report. The sample selected for the matrix spike and matrix spike duplicate was not from this work order. The LCS was within control limits for these analytes. No further corrective actions were taken.

For Metals analysis performed on 5/21/19 the RPD for the serial dilution was slightly above control limits for Potassium. This is flagged accordingly. The PDS was within control limits for this analyte. No further corrective actions were taken.

For Metals analysis performed on 5/21/19 the PDS recovery was out of control limits for three analytes. These are flagged accordingly. The serial dilution was within control limits for these analytes. No further corrective actions were taken.

For Metals analysis performed on 5/21/19 three LCVLs were out of control limits for Potassium and/or Sodium. These are flagged accordingly. The associated CCVs were within control limits for these analytes. No further corrective actions were taken.

ANIONS ANALYSIS

CLIENT: Golder
Project: Luminant-MLSES Ash Ponds
Lab Order: 1905167

CASE NARRATIVE

For Anions analysis performed on 5/15/19 (batch 90908) the matrix spike and matrix spike duplicate recoveries (1905167-02 MS/MSD) were out of control limits for Chloride and Sulfate. These are flagged accordingly in the QC summary report. The sample selected for the matrix spike and matrix spike duplicate was from this work order. The LCS was within control limits for these analytes. No further corrective actions were taken.

LUMINANT

CLIENT: Golder
Project: Luminant-MLSES Ash Ponds
Lab Order: 1905167

Work Order Sample Summary

Lab Smp ID	Client Sample ID	Tag Number	Date Collected	Date Recved
1905167-01	Lake Sample		05/14/19 10:05 AM	5/15/2019
1905167-02	Pond Sample		05/14/19 10:20 AM	5/15/2019

LUMINANT

Lab Order: 1905167
Client: Golder
Project: Luminant-MLSES Ash Ponds

PREP DATES REPORT

Sample ID	Client Sample ID	Collection Date	Matrix	Test Number	Test Name	Prep Date	Batch ID
1905167-01A	Lake Sample	05/14/19 10:05 AM	Aqueous	M3500-Fe	Ferrous Iron Prep Water	05/20/19 02:56 PM	91002
1905167-01B	Lake Sample	05/14/19 10:05 AM	Aqueous	SW3005A	Aq Prep Metals : ICP-MS	05/20/19 09:34 AM	90990
	Lake Sample	05/14/19 10:05 AM	Aqueous	SW3005A	Aq Prep Metals : ICP-MS	05/20/19 09:34 AM	90990
	Lake Sample	05/14/19 10:05 AM	Aqueous	SW7470A	Mercury Aq Prep	05/21/19 09:56 AM	91017
1905167-01C	Lake Sample	05/14/19 10:05 AM	Aqueous	M2320 B	Alkalinity Preparation	05/16/19 10:12 AM	90940
	Lake Sample	05/14/19 10:05 AM	Aqueous	E300	Anion Preparation	05/15/19 09:07 AM	90908
	Lake Sample	05/14/19 10:05 AM	Aqueous	E300	Anion Preparation	05/15/19 09:07 AM	90908
	Lake Sample	05/14/19 10:05 AM	Aqueous	M4500-P E	Orthophosphate Prep	05/15/19 12:12 PM	90921
	Lake Sample	05/14/19 10:05 AM	Aqueous	M2540C	TDS Preparation	05/16/19 03:23 PM	90953
1905167-02A	Pond Sample	05/14/19 10:20 AM	Aqueous	M3500-Fe	Ferrous Iron Prep Water	05/20/19 02:56 PM	91002
1905167-02B	Pond Sample	05/14/19 10:20 AM	Aqueous	SW3005A	Aq Prep Metals : ICP-MS	05/20/19 09:34 AM	90990
	Pond Sample	05/14/19 10:20 AM	Aqueous	SW3005A	Aq Prep Metals : ICP-MS	05/20/19 09:34 AM	90990
	Pond Sample	05/14/19 10:20 AM	Aqueous	SW7470A	Mercury Aq Prep	05/21/19 09:56 AM	91017
1905167-02C	Pond Sample	05/14/19 10:20 AM	Aqueous	M2320 B	Alkalinity Preparation	05/16/19 10:12 AM	90940
	Pond Sample	05/14/19 10:20 AM	Aqueous	E300	Anion Preparation	05/15/19 09:07 AM	90908
	Pond Sample	05/14/19 10:20 AM	Aqueous	E300	Anion Preparation	05/15/19 09:07 AM	90908
	Pond Sample	05/14/19 10:20 AM	Aqueous	E300	Anion Preparation	05/16/19 09:16 AM	90935
	Pond Sample	05/14/19 10:20 AM	Aqueous	M4500-P E	Orthophosphate Prep	05/15/19 12:12 PM	90921
	Pond Sample	05/14/19 10:20 AM	Aqueous	M2540C	TDS Preparation	05/16/19 03:23 PM	90953

Lab Order: 1905167
Client: Golder
Project: Luminant-MLSES Ash Ponds

ANALYTICAL DATES REPORT

Sample ID	Client Sample ID	Matrix	Test Number	Test Name	Batch ID	Dilution	Analysis Date	Run ID
1905167-01A	Lake Sample	Aqueous	M3500-Fe D	Ferric Iron (Calculated)	91002	1	05/24/19	UV/VIS_2_190524A
	Lake Sample	Aqueous	M3500-Fe D	Ferrous Iron	91002	1	05/20/19 03:54 PM	UV/VIS_2_190520A
1905167-01B	Lake Sample	Aqueous	SW7470A	Mercury Total: Aqueous	91017	1	05/22/19 10:11 AM	CETAC2_HG_190522 A
	Lake Sample	Aqueous	SW6020A	Trace Metals: ICP-MS - Water	90990	1	05/22/19 12:01 PM	ICP-MS4_190522B
	Lake Sample	Aqueous	SW6020A	Trace Metals: ICP-MS - Water	90990	1	05/21/19 03:24 PM	ICP-MS5_190521A
1905167-01C	Lake Sample	Aqueous	M2320 B	Alkalinity	90940	1	05/16/19 04:05 PM	TITRATOR_190516A
	Lake Sample	Aqueous	E300	Anions by IC method - Water	90908	10	05/15/19 12:51 PM	IC2_190515A
	Lake Sample	Aqueous	E300	Anions by IC method - Water	90908	1	05/15/19 05:23 PM	IC2_190515A
	Lake Sample	Aqueous	M4500-P E	Orthophosphate	90921	1	05/15/19 02:47 PM	UV/VIS_2_190515B
	Lake Sample	Aqueous	M2540C	Total Dissolved Solids	90953	1	05/17/19 11:40 AM	WC_190517D
1905167-02A	Pond Sample	Aqueous	M3500-Fe D	Ferric Iron (Calculated)	91002	1	05/24/19	UV/VIS_2_190524A
	Pond Sample	Aqueous	M3500-Fe D	Ferrous Iron	91002	1	05/20/19 03:54 PM	UV/VIS_2_190520A
1905167-02B	Pond Sample	Aqueous	SW7470A	Mercury Total: Aqueous	91017	1	05/22/19 10:13 AM	CETAC2_HG_190522 A
	Pond Sample	Aqueous	SW6020A	Trace Metals: ICP-MS - Water	90990	100	05/22/19 12:03 PM	ICP-MS4_190522B
	Pond Sample	Aqueous	SW6020A	Trace Metals: ICP-MS - Water	90990	1	05/21/19 03:26 PM	ICP-MS5_190521A
1905167-02C	Pond Sample	Aqueous	M2320 B	Alkalinity	90940	1	05/16/19 04:08 PM	TITRATOR_190516A
	Pond Sample	Aqueous	E300	Anions by IC method - Water	90908	10	05/15/19 01:39 PM	IC2_190515A
	Pond Sample	Aqueous	E300	Anions by IC method - Water	90908	1	05/15/19 05:39 PM	IC2_190515A
	Pond Sample	Aqueous	E300	Anions by IC method - Water	90935	100	05/16/19 04:54 PM	IC4_190516A
	Pond Sample	Aqueous	M4500-P E	Orthophosphate	90921	1	05/15/19 02:47 PM	UV/VIS_2_190515B
	Pond Sample	Aqueous	M2540C	Total Dissolved Solids	90953	1	05/17/19 11:40 AM	WC_190517D

CLIENT: Golder
Project: Luminant-MLSES Ash Ponds
Project No: 19122262-C
Lab Order: 1905167

Client Sample ID: Lake Sample
Lab ID: 1905167-01
Collection Date: 05/14/19 10:05 AM
Matrix: AQUEOUS

Analyses	Result	MDL	RL	Qual	Units	DF	Date Analyzed
TRACE METALS: ICP-MS - WATER		SW6020A		Analyst: RO			
Antimony	<0.000800	0.000800	0.00250		mg/L	1	05/21/19 03:24 PM
Arsenic	<0.00200	0.00200	0.00500		mg/L	1	05/21/19 03:24 PM
Barium	0.0535	0.00300	0.0100		mg/L	1	05/21/19 03:24 PM
Beryllium	<0.000300	0.000300	0.00100		mg/L	1	05/21/19 03:24 PM
Boron	0.0632	0.0100	0.0300		mg/L	1	05/22/19 12:01 PM
Cadmium	<0.000300	0.000300	0.00100		mg/L	1	05/21/19 03:24 PM
Calcium	12.5	0.100	0.300		mg/L	1	05/21/19 03:24 PM
Chromium	<0.00200	0.00200	0.00500		mg/L	1	05/21/19 03:24 PM
Cobalt	<0.00300	0.00300	0.00500		mg/L	1	05/21/19 03:24 PM
Iron	0.365	0.0300	0.100		mg/L	1	05/21/19 03:24 PM
Lead	<0.000300	0.000300	0.00100		mg/L	1	05/21/19 03:24 PM
Lithium	<0.00500	0.00500	0.0100		mg/L	1	05/21/19 03:24 PM
Magnesium	6.09	0.100	0.300		mg/L	1	05/21/19 03:24 PM
Molybdenum	<0.00200	0.00200	0.00500		mg/L	1	05/21/19 03:24 PM
Potassium	2.56	0.100	0.300		mg/L	1	05/21/19 03:24 PM
Selenium	<0.00200	0.00200	0.00500		mg/L	1	05/21/19 03:24 PM
Sodium	11.9	0.100	0.300		mg/L	1	05/21/19 03:24 PM
Thallium	<0.000500	0.000500	0.00150		mg/L	1	05/21/19 03:24 PM
MERCURY TOTAL: AQUEOUS		SW7470A		Analyst: BM			
Mercury	<0.0000800	0.0000800	0.000200		mg/L	1	05/22/19 10:11 AM
ANIONS BY IC METHOD - WATER		E300		Analyst: JL			
Chloride	12.2	0.300	1.00		mg/L	1	05/15/19 05:23 PM
Fluoride	0.140	0.100	0.400	J	mg/L	1	05/15/19 05:23 PM
Nitrate-N	<0.100	0.100	0.500		mg/L	1	05/15/19 05:23 PM
Sulfate	37.3	1.00	3.00		mg/L	1	05/15/19 05:23 PM
ALKALINITY		M2320 B		Analyst: CC			
Alkalinity, Bicarbonate (As CaCO3)	55.4	10.0	20.0		mg/L @ pH 4.5	1	05/16/19 04:05 PM
Alkalinity, Carbonate (As CaCO3)	<10.0	10.0	20.0		mg/L @ pH 4.5	1	05/16/19 04:05 PM
Alkalinity, Hydroxide (As CaCO3)	<10.0	10.0	20.0		mg/L @ pH 4.5	1	05/16/19 04:05 PM
Alkalinity, Total (As CaCO3)	55.4	20.0	20.0		mg/L @ pH 4.5	1	05/16/19 04:05 PM
FERRIC IRON (CALCULATED)		M3500-FE D		Analyst: CAC			
Iron, Ferric	0.365	0.0500	0.100	N	mg/L	1	05/24/19
FERROUS IRON		M3500-FE D		Analyst: BTJ			
Iron, Ferrous	<0.0500	0.0500	0.100	N	mg/L	1	05/20/19 03:54 PM

Qualifiers:

*	Value exceeds TCLP Maximum Concentration Level	C	Sample Result or QC discussed in the Case Narrative
DF	Dilution Factor	E	TPH pattern not Gas or Diesel Range Pattern
J	Analyte detected between MDL and RL	MDL	Method Detection Limit
ND	Not Detected at the Method Detection Limit	RL	Reporting Limit
S	Spike Recovery outside control limits	N	Parameter not NELAP certified

DHL Analytical, Inc.

Date: 30-May-19

CLIENT: Golder
Project: Luminant-MLSES Ash Ponds
Project No: 19122262-C
Lab Order: 1905167

Client Sample ID: Lake Sample
Lab ID: 1905167-01
Collection Date: 05/14/19 10:05 AM
Matrix: AQUEOUS

Analyses	Result	MDL	RL	Qual	Units	DF	Date Analyzed
ORTHOPHOSPHATE							Analyst: CC
Phosphorus, Total Orthophosphate (As P)	<0.0300	0.0300	0.100		mg/L	1	05/15/19 02:47 PM
TOTAL DISSOLVED SOLIDS							Analyst: JS
Total Dissolved Solids (Residue, Filterable)	119	10.0	10.0		mg/L	1	05/17/19 11:40 AM

LUMINANT

Qualifiers:

*	Value exceeds TCLP Maximum Concentration Level	C	Sample Result or QC discussed in the Case Narrative
DF	Dilution Factor	E	TPH pattern not Gas or Diesel Range Pattern
J	Analyte detected between MDL and RL	MDL	Method Detection Limit
ND	Not Detected at the Method Detection Limit	RL	Reporting Limit
S	Spike Recovery outside control limits	N	Parameter not NELAP certified

CLIENT: Golder
Project: Luminant-MLSES Ash Ponds
Project No: 19122262-C
Lab Order: 1905167

Client Sample ID: Pond Sample
Lab ID: 1905167-02
Collection Date: 05/14/19 10:20 AM
Matrix: AQUEOUS

Analyses	Result	MDL	RL	Qual	Units	DF	Date Analyzed
TRACE METALS: ICP-MS - WATER		SW6020A			Analyst: RO		
Antimony	0.00199	0.000800	0.00250	J	mg/L	1	05/21/19 03:26 PM
Arsenic	0.00305	0.00200	0.00500	J	mg/L	1	05/21/19 03:26 PM
Barium	0.0589	0.00300	0.0100		mg/L	1	05/21/19 03:26 PM
Beryllium	<0.000300	0.000300	0.00100		mg/L	1	05/21/19 03:26 PM
Boron	28.2	1.00	3.00		mg/L	100	05/22/19 12:03 PM
Cadmium	<0.000300	0.000300	0.00100		mg/L	1	05/21/19 03:26 PM
Calcium	319	10.0	30.0		mg/L	100	05/22/19 12:03 PM
Chromium	0.00336	0.00200	0.00500	J	mg/L	1	05/21/19 03:26 PM
Cobalt	<0.00300	0.00300	0.00500		mg/L	1	05/21/19 03:26 PM
Iron	<0.0300	0.0300	0.100		mg/L	1	05/21/19 03:26 PM
Lead	<0.000300	0.000300	0.00100		mg/L	1	05/21/19 03:26 PM
Lithium	0.119	0.00500	0.0100		mg/L	1	05/21/19 03:26 PM
Magnesium	553	10.0	30.0		mg/L	100	05/22/19 12:03 PM
Molybdenum	0.0550	0.00200	0.00500		mg/L	1	05/21/19 03:26 PM
Potassium	34.6	10.0	30.0		mg/L	100	05/22/19 12:03 PM
Selenium	2.96	0.200	0.500		mg/L	100	05/22/19 12:03 PM
Sodium	240	10.0	30.0		mg/L	100	05/22/19 12:03 PM
Thallium	<0.000500	0.000500	0.00150		mg/L	1	05/21/19 03:26 PM
MERCURY TOTAL: AQUEOUS		SW7470A			Analyst: BM		
Mercury	0.000119	0.0000800	0.000200	J	mg/L	1	05/22/19 10:13 AM
ANIONS BY IC METHOD - WATER		E300			Analyst: JL		
Chloride	513	30.0	100		mg/L	100	05/16/19 04:54 PM
Fluoride	24.3	1.00	4.00		mg/L	10	05/15/19 01:39 PM
Nitrate-N	11.1	0.100	0.500		mg/L	1	05/15/19 05:39 PM
Sulfate	2900	100	300		mg/L	100	05/16/19 04:54 PM
ALKALINITY		M2320 B			Analyst: CC		
Alkalinity, Bicarbonate (As CaCO3)	79.1	10.0	20.0		mg/L @ pH 4.52	1	05/16/19 04:08 PM
Alkalinity, Carbonate (As CaCO3)	<10.0	10.0	20.0		mg/L @ pH 4.52	1	05/16/19 04:08 PM
Alkalinity, Hydroxide (As CaCO3)	<10.0	10.0	20.0		mg/L @ pH 4.52	1	05/16/19 04:08 PM
Alkalinity, Total (As CaCO3)	79.1	20.0	20.0		mg/L @ pH 4.52	1	05/16/19 04:08 PM
FERRIC IRON (CALCULATED)		M3500-FE D			Analyst: CAC		
Iron, Ferric	<0.0500	0.0500	0.100	N	mg/L	1	05/24/19
FERROUS IRON		M3500-FE D			Analyst: BTJ		
Iron, Ferrous	<0.0500	0.0500	0.100	N	mg/L	1	05/20/19 03:54 PM

Qualifiers: * Value exceeds TCLP Maximum Concentration Level C Sample Result or QC discussed in the Case Narrative
 DF Dilution Factor E TPH pattern not Gas or Diesel Range Pattern
 J Analyte detected between MDL and RL MDL Method Detection Limit
 ND Not Detected at the Method Detection Limit RL Reporting Limit
 S Spike Recovery outside control limits N Parameter not NELAP certified

DHL Analytical, Inc.

Date: 30-May-19

CLIENT: Golder
Project: Luminant-MLSES Ash Ponds
Project No: 19122262-C
Lab Order: 1905167

Client Sample ID: Pond Sample
Lab ID: 1905167-02
Collection Date: 05/14/19 10:20 AM
Matrix: AQUEOUS

Analyses	Result	MDL	RL	Qual	Units	DF	Date Analyzed
ORTHOPHOSPHATE							Analyst: CC
Phosphorus, Total Orthophosphate (As P)	<0.0300	0.0300	0.100		mg/L	1	05/15/19 02:47 PM
TOTAL DISSOLVED SOLIDS							Analyst: JS
Total Dissolved Solids (Residue, Filterable)	5380	50.0	50.0		mg/L	1	05/17/19 11:40 AM

LUMINANT

Qualifiers:

*	Value exceeds TCLP Maximum Concentration Level	C	Sample Result or QC discussed in the Case Narrative
DF	Dilution Factor	E	TPH pattern not Gas or Diesel Range Pattern
J	Analyte detected between MDL and RL	MDL	Method Detection Limit
ND	Not Detected at the Method Detection Limit	RL	Reporting Limit
S	Spike Recovery outside control limits	N	Parameter not NELAP certified

CLIENT: Golder
Work Order: 1905167

ANALYTICAL QC SUMMARY REPORT

Project: Luminant-MLSES Ash Ponds

RunID: CETAC2_HG_190522A

The QC data in batch 91017 applies to the following samples: 1905167-01B, 1905167-02B

Sample ID MB-91017	Batch ID: 91017	TestNo: SW7470A	Units: mg/L							
SampType: MBLK	Run ID: CETAC2_HG_190522A	Analysis Date: 5/22/2019 10:02:31 AM	Prep Date: 5/21/2019							
Analyte	Result	RL	SPK value	Ref Val	%REC	LowLimit	HighLimit	%RPD	RPDLimit	Qual

Mercury <0.0000800 0.000200

Sample ID LCS-91017	Batch ID: 91017	TestNo: SW7470A	Units: mg/L							
SampType: LCS	Run ID: CETAC2_HG_190522A	Analysis Date: 5/22/2019 10:04:46 AM	Prep Date: 5/21/2019							
Analyte	Result	RL	SPK value	Ref Val	%REC	LowLimit	HighLimit	%RPD	RPDLimit	Qual

Mercury 0.00187 0.000200 0.00200 0 93.5 85 115

Sample ID LCS-91017	Batch ID: 91017	TestNo: SW7470A	Units: mg/L							
SampType: LCS	Run ID: CETAC2_HG_190522A	Analysis Date: 5/22/2019 10:07:02 AM	Prep Date: 5/21/2019							
Analyte	Result	RL	SPK value	Ref Val	%REC	LowLimit	HighLimit	%RPD	RPDLimit	Qual

Mercury 0.00186 0.000200 0.00200 0 93.0 85 115 0.536 15

Sample ID 1905168-01B MS	Batch ID: 91017	TestNo: SW7470A	Units: mg/L							
SampType: MS	Run ID: CETAC2_HG_190522A	Analysis Date: 5/22/2019 11:23:23 AM	Prep Date: 5/21/2019							
Analyte	Result	RL	SPK value	Ref Val	%REC	LowLimit	HighLimit	%RPD	RPDLimit	Qual

Mercury 0.00196 0.00100 0.00200 0 97.8 80 120

Sample ID 1905168-01B MSD	Batch ID: 91017	TestNo: SW7470A	Units: mg/L							
SampType: MSD	Run ID: CETAC2_HG_190522A	Analysis Date: 5/22/2019 11:25:39 AM	Prep Date: 5/21/2019							
Analyte	Result	RL	SPK value	Ref Val	%REC	LowLimit	HighLimit	%RPD	RPDLimit	Qual

Mercury 0.00194 0.00100 0.00200 0 97.0 80 120 0.770 15

Sample ID 1905168-01B SD	Batch ID: 91017	TestNo: SW7470A	Units: mg/L							
SampType: SD	Run ID: CETAC2_HG_190522A	Analysis Date: 5/22/2019 11:27:56 AM	Prep Date: 5/21/2019							
Analyte	Result	RL	SPK value	Ref Val	%REC	LowLimit	HighLimit	%RPD	RPDLimit	Qual

Mercury <0.00200 0.00500 0 0 0 0 10

Sample ID 1905168-01B PDS	Batch ID: 91017	TestNo: SW7470A	Units: mg/L							
SampType: PDS	Run ID: CETAC2_HG_190522A	Analysis Date: 5/22/2019 11:30:13 AM	Prep Date: 5/21/2019							
Analyte	Result	RL	SPK value	Ref Val	%REC	LowLimit	HighLimit	%RPD	RPDLimit	Qual

Mercury 0.0122 0.00100 0.0125 0 97.6 85 115

- Qualifiers:**
- B Analyte detected in the associated Method Blank
 - J Analyte detected between MDL and RL
 - ND Not Detected at the Method Detection Limit
 - RL Reporting Limit
 - J Analyte detected between SDL and RL
 - DF Dilution Factor
 - MDL Method Detection Limit
 - R RPD outside accepted control limits
 - S Spike Recovery outside control limits
 - N Parameter not NELAP certified

CLIENT: Golder
Work Order: 1905167
Project: Luminant-MLSES Ash Ponds

ANALYTICAL QC SUMMARY REPORT

RunID: CETAC2_HG_190522A

Sample ID ICV-190522	Batch ID: R104223	TestNo: SW7470A	Units: mg/L							
SampType: ICV	Run ID: CETAC2_HG_190522A	Analysis Date: 5/22/2019 9:57:56 AM	Prep Date:							
Analyte	Result	RL	SPK value	Ref Val	%REC	LowLimit	HighLimit	%RPD	RPDLimit	Qual

Mercury	0.00383	0.000200	0.00400	0	95.8	90	110			
---------	---------	----------	---------	---	------	----	-----	--	--	--

Sample ID CCV1-190522	Batch ID: R104223	TestNo: SW7470A	Units: mg/L							
SampType: CCV	Run ID: CETAC2_HG_190522A	Analysis Date: 5/22/2019 10:41:04 AM	Prep Date:							
Analyte	Result	RL	SPK value	Ref Val	%REC	LowLimit	HighLimit	%RPD	RPDLimit	Qual

Mercury	0.00202	0.000200	0.00200	0	101	90	110			
---------	---------	----------	---------	---	-----	----	-----	--	--	--

Sample ID CCV2-190522	Batch ID: R104223	TestNo: SW7470A	Units: mg/L							
SampType: CCV	Run ID: CETAC2_HG_190522A	Analysis Date: 5/22/2019 11:08:23 AM	Prep Date:							
Analyte	Result	RL	SPK value	Ref Val	%REC	LowLimit	HighLimit	%RPD	RPDLimit	Qual

Mercury	0.00203	0.000200	0.00200	0	102	90	110			
---------	---------	----------	---------	---	-----	----	-----	--	--	--

Sample ID CCV3-190522	Batch ID: R104223	TestNo: SW7470A	Units: mg/L							
SampType: CCV	Run ID: CETAC2_HG_190522A	Analysis Date: 5/22/2019 2:51:11 PM	Prep Date:							
Analyte	Result	RL	SPK value	Ref Val	%REC	LowLimit	HighLimit	%RPD	RPDLimit	Qual

Mercury	0.00203	0.000200	0.00200	0	102	90	110			
---------	---------	----------	---------	---	-----	----	-----	--	--	--

Qualifiers:	B Analyte detected in the associated Method Blank	DF Dilution Factor
	J Analyte detected between MDL and RL	MDL Method Detection Limit
	ND Not Detected at the Method Detection Limit	R RPD outside accepted control limits
	RL Reporting Limit	S Spike Recovery outside control limits
	J Analyte detected between SDL and RL	N Parameter not NELAP certified

CLIENT: Golder
Work Order: 1905167
Project: Luminant-MLSES Ash Ponds

ANALYTICAL QC SUMMARY REPORT

RunID: ICP-MS4_190522B

The QC data in batch 90990 applies to the following samples: 1905167-01B, 1905167-02B

Sample ID: MB-90990	Batch ID: 90990	TestNo: SW6020A	Units: mg/L							
SampType: MBLK	Run ID: ICP-MS4_190522B	Analysis Date: 5/22/2019 11:49:00 AM	Prep Date: 5/20/2019							
Analyte	Result	RL	SPK value	Ref Val	%REC	LowLimit	HighLimit	%RPD	RPDLimit	Qual

Boron	<0.0100	0.0300								
-------	---------	--------	--	--	--	--	--	--	--	--

Sample ID: LCS-90990	Batch ID: 90990	TestNo: SW6020A	Units: mg/L							
SampType: LCS	Run ID: ICP-MS4_190522B	Analysis Date: 5/22/2019 11:51:00 AM	Prep Date: 5/20/2019							
Analyte	Result	RL	SPK value	Ref Val	%REC	LowLimit	HighLimit	%RPD	RPDLimit	Qual

Boron	0.203	0.0300	0.200	0	102	80	120			
-------	-------	--------	-------	---	-----	----	-----	--	--	--

Sample ID: LCSD-90990	Batch ID: 90990	TestNo: SW6020A	Units: mg/L							
SampType: LCSD	Run ID: ICP-MS4_190522B	Analysis Date: 5/22/2019 11:53:00 AM	Prep Date: 5/20/2019							
Analyte	Result	RL	SPK value	Ref Val	%REC	LowLimit	HighLimit	%RPD	RPDLimit	Qual

Boron	0.202	0.0300	0.200	0	101	80	120	0.579	15	
-------	-------	--------	-------	---	-----	----	-----	-------	----	--

Sample ID: 1905218-06A SD	Batch ID: 90990	TestNo: SW6020A	Units: mg/L							
SampType: SD	Run ID: ICP-MS4_190522B	Analysis Date: 5/22/2019 11:59:00 AM	Prep Date: 5/20/2019							
Analyte	Result	RL	SPK value	Ref Val	%REC	LowLimit	HighLimit	%RPD	RPDLimit	Qual

Boron	0.103	0.150	0	0.0953				7.85	10	
-------	-------	-------	---	--------	--	--	--	------	----	--

Sample ID: 1905218-06A PDS	Batch ID: 90990	TestNo: SW6020A	Units: mg/L							
SampType: PDS	Run ID: ICP-MS4_190522B	Analysis Date: 5/22/2019 12:23:00 PM	Prep Date: 5/20/2019							
Analyte	Result	RL	SPK value	Ref Val	%REC	LowLimit	HighLimit	%RPD	RPDLimit	Qual

Boron	0.277	0.0300	0.200	0.0953	91.1	80	120			
-------	-------	--------	-------	--------	------	----	-----	--	--	--

Sample ID: 1905218-06A MS	Batch ID: 90990	TestNo: SW6020A	Units: mg/L							
SampType: MS	Run ID: ICP-MS4_190522B	Analysis Date: 5/22/2019 12:25:00 PM	Prep Date: 5/20/2019							
Analyte	Result	RL	SPK value	Ref Val	%REC	LowLimit	HighLimit	%RPD	RPDLimit	Qual

Boron	0.288	0.0300	0.200	0.0953	96.1	80	120			
-------	-------	--------	-------	--------	------	----	-----	--	--	--

Sample ID: 1905218-06A MSD	Batch ID: 90990	TestNo: SW6020A	Units: mg/L							
SampType: MSD	Run ID: ICP-MS4_190522B	Analysis Date: 5/22/2019 12:27:00 PM	Prep Date: 5/20/2019							
Analyte	Result	RL	SPK value	Ref Val	%REC	LowLimit	HighLimit	%RPD	RPDLimit	Qual

Boron	0.282	0.0300	0.200	0.0953	93.3	80	120	2.01	15	
-------	-------	--------	-------	--------	------	----	-----	------	----	--

- | | |
|--|---|
| <p>Qualifiers:</p> <ul style="list-style-type: none"> B Analyte detected in the associated Method Blank J Analyte detected between MDL and RL ND Not Detected at the Method Detection Limit RL Reporting Limit J Analyte detected between SDL and RL | <ul style="list-style-type: none"> DF Dilution Factor MDL Method Detection Limit R RPD outside accepted control limits S Spike Recovery outside control limits N Parameter not NELAP certified |
|--|---|

CLIENT: Golder
Work Order: 1905167
Project: Luminant-MLSES Ash Ponds

ANALYTICAL QC SUMMARY REPORT

RunID: ICP-MS4_190522B

Sample ID ICV-190522	Batch ID: R104220	TestNo: SW6020A	Units: mg/L
SampType: ICV	Run ID: ICP-MS4_190522B	Analysis Date: 5/22/2019 11:38:00 AM	Prep Date:

Analyte	Result	RL	SPK value	Ref Val	%REC	LowLimit	HighLimit	%RPD	RPDLimit	Qual
Boron	0.104	0.0300	0.100	0	104	90	110			
Calcium	2.35	0.300	2.50	0	94.2	90	110			
Magnesium	2.45	0.300	2.50	0	98.2	90	110			
Potassium	2.52	0.300	2.50	0	101	90	110			
Selenium	0.102	0.00500	0.100	0	102	90	110			
Sodium	2.53	0.300	2.50	0	101	90	110			

Sample ID LCVL-190522	Batch ID: R104220	TestNo: SW6020A	Units: mg/L
SampType: LCVL	Run ID: ICP-MS4_190522B	Analysis Date: 5/22/2019 11:43:00 AM	Prep Date:

Analyte	Result	RL	SPK value	Ref Val	%REC	LowLimit	HighLimit	%RPD	RPDLimit	Qual
Boron	0.0197	0.0300	0.0200	0	98.5	70	130			
Calcium	0.0981	0.300	0.100	0	98.1	70	130			
Magnesium	0.0967	0.300	0.100	0	96.7	70	130			
Potassium	0.0964	0.300	0.100	0	96.4	70	130			
Selenium	0.00494	0.00500	0.00500	0	98.8	70	130			
Sodium	0.0966	0.300	0.100	0	96.6	70	130			

Sample ID CCV1-190522	Batch ID: R104220	TestNo: SW6020A	Units: mg/L
SampType: CCV	Run ID: ICP-MS4_190522B	Analysis Date: 5/22/2019 12:33:00 PM	Prep Date:

Analyte	Result	RL	SPK value	Ref Val	%REC	LowLimit	HighLimit	%RPD	RPDLimit	Qual
Boron	0.210	0.0300	0.200	0	105	90	110			
Calcium	4.65	0.300	5.00	0	92.9	90	110			
Magnesium	5.05	0.300	5.00	0	101	90	110			
Potassium	5.15	0.300	5.00	0	103	90	110			
Selenium	0.215	0.00500	0.200	0	107	90	110			
Sodium	5.08	0.300	5.00	0	102	90	110			

Sample ID LCVL1-190522	Batch ID: R104220	TestNo: SW6020A	Units: mg/L
SampType: LCVL	Run ID: ICP-MS4_190522B	Analysis Date: 5/22/2019 12:38:00 PM	Prep Date:

Analyte	Result	RL	SPK value	Ref Val	%REC	LowLimit	HighLimit	%RPD	RPDLimit	Qual
Boron	0.0203	0.0300	0.0200	0	102	70	130			
Calcium	0.0876	0.300	0.100	0	87.6	70	130			
Magnesium	0.0970	0.300	0.100	0	97.0	70	130			
Potassium	0.0932	0.300	0.100	0	93.2	70	130			
Selenium	0.00547	0.00500	0.00500	0	109	70	130			
Sodium	0.102	0.300	0.100	0	102	70	130			

Qualifiers: B Analyte detected in the associated Method Blank DF Dilution Factor
J Analyte detected between MDL and RL MDL Method Detection Limit
ND Not Detected at the Method Detection Limit R RPD outside accepted control limits
RL Reporting Limit S Spike Recovery outside control limits
J Analyte detected between SDL and RL N Parameter not NELAP certified

CLIENT: Golder
Work Order: 1905167
Project: Luminant-MLSES Ash Ponds

ANALYTICAL QC SUMMARY REPORT

RunID: ICP-MS5_190521A

The QC data in batch 90990 applies to the following samples: 1905167-01B, 1905167-02B

Sample ID: MB-90990	Batch ID: 90990	TestNo: SW6020A	Units: mg/L
SampType: MBLK	Run ID: ICP-MS5_190521A	Analysis Date: 5/21/2019 3:11:00 PM	Prep Date: 5/20/2019

Analyte	Result	RL	SPK value	Ref Val	%REC	LowLimit	HighLimit	%RPD	RPDLimit	Qual
Antimony	<0.000800	0.00250								
Arsenic	<0.00200	0.00500								
Barium	<0.00300	0.0100								
Beryllium	<0.000300	0.00100								
Cadmium	<0.000300	0.00100								
Calcium	<0.100	0.300								
Chromium	<0.00200	0.00500								
Cobalt	<0.00300	0.00500								
Iron	<0.0300	0.100								
Lead	<0.000300	0.00100								
Lithium	<0.00500	0.0100								
Magnesium	<0.100	0.300								
Molybdenum	<0.00200	0.00500								
Potassium	<0.100	0.300								
Selenium	<0.00200	0.00500								
Sodium	<0.100	0.300								
Thallium	<0.000500	0.00150								

Sample ID: LCS-90990	Batch ID: 90990	TestNo: SW6020A	Units: mg/L
SampType: LCS	Run ID: ICP-MS5_190521A	Analysis Date: 5/21/2019 3:13:00 PM	Prep Date: 5/20/2019

Analyte	Result	RL	SPK value	Ref Val	%REC	LowLimit	HighLimit	%RPD	RPDLimit	Qual
Antimony	0.209	0.00250	0.200	0	104	80	120			
Arsenic	0.208	0.00500	0.200	0	104	80	120			
Barium	0.208	0.0100	0.200	0	104	80	120			
Beryllium	0.200	0.00100	0.200	0	99.8	80	120			
Cadmium	0.211	0.00100	0.200	0	105	80	120			
Calcium	5.18	0.300	5.00	0	104	80	120			
Chromium	0.209	0.00500	0.200	0	105	80	120			
Cobalt	0.216	0.00500	0.200	0	108	80	120			
Iron	5.40	0.100	5.00	0	108	80	120			
Lead	0.203	0.00100	0.200	0	101	80	120			
Lithium	0.214	0.0100	0.200	0	107	80	120			
Magnesium	5.35	0.300	5.00	0	107	80	120			
Molybdenum	0.204	0.00500	0.200	0	102	80	120			
Potassium	4.99	0.300	5.00	0	99.9	80	120			
Selenium	0.208	0.00500	0.200	0	104	80	120			
Sodium	5.38	0.300	5.00	0	108	80	120			
Thallium	0.200	0.00150	0.200	0	100	80	120			

<p>Qualifiers:</p> <p>B Analyte detected in the associated Method Blank</p> <p>J Analyte detected between MDL and RL</p> <p>ND Not Detected at the Method Detection Limit</p> <p>RL Reporting Limit</p> <p>J Analyte detected between SDL and RL</p>	<p>DF Dilution Factor</p> <p>MDL Method Detection Limit</p> <p>R RPD outside accepted control limits</p> <p>S Spike Recovery outside control limits</p> <p>N Parameter not NELAP certified</p>
---	--

CLIENT: Golder
Work Order: 1905167
Project: Luminant-MLSES Ash Ponds

ANALYTICAL QC SUMMARY REPORT

RunID: ICP-MS5_190521A

Sample ID: LCSD-90990	Batch ID: 90990	TestNo: SW6020A	Units: mg/L
SampType: LCSD	Run ID: ICP-MS5_190521A	Analysis Date: 5/21/2019 3:15:00 PM	Prep Date: 5/20/2019

Analyte	Result	RL	SPK value	Ref Val	%REC	LowLimit	HighLimit	%RPD	RPDLimit	Qual
Antimony	0.209	0.00250	0.200	0	105	80	120	0.307	15	
Arsenic	0.207	0.00500	0.200	0	104	80	120	0.318	15	
Barium	0.207	0.0100	0.200	0	103	80	120	0.392	15	
Beryllium	0.198	0.00100	0.200	0	99.0	80	120	0.810	15	
Cadmium	0.211	0.00100	0.200	0	105	80	120	0.119	15	
Calcium	5.16	0.300	5.00	0	103	80	120	0.293	15	
Chromium	0.209	0.00500	0.200	0	105	80	120	0.129	15	
Cobalt	0.215	0.00500	0.200	0	108	80	120	0.352	15	
Iron	5.41	0.100	5.00	0	108	80	120	0.077	15	
Lead	0.204	0.00100	0.200	0	102	80	120	0.722	15	
Lithium	0.211	0.0100	0.200	0	105	80	120	1.44	15	
Magnesium	5.37	0.300	5.00	0	107	80	120	0.251	15	
Molybdenum	0.202	0.00500	0.200	0	101	80	120	0.822	15	
Potassium	5.00	0.300	5.00	0	100	80	120	0.175	15	
Selenium	0.208	0.00500	0.200	0	104	80	120	0.274	15	
Sodium	5.38	0.300	5.00	0	108	80	120	0.080	15	
Thallium	0.202	0.00150	0.200	0	101	80	120	0.737	15	

Sample ID: 1905218-06A SD	Batch ID: 90990	TestNo: SW6020A	Units: mg/L
SampType: SD	Run ID: ICP-MS5_190521A	Analysis Date: 5/21/2019 3:22:00 PM	Prep Date: 5/20/2019

Analyte	Result	RL	SPK value	Ref Val	%REC	LowLimit	HighLimit	%RPD	RPDLimit	Qual
Antimony	<0.00400	0.0125	0	0				0	10	
Arsenic	<0.0100	0.0250	0	0				0	10	
Barium	0.0519	0.0500	0	0.0510				1.62	10	
Beryllium	<0.00150	0.00500	0	0				0	10	
Cadmium	<0.00150	0.00500	0	0				0	10	
Calcium	23.9	1.50	0	23.8				0.464	10	
Chromium	<0.0100	0.0250	0	0				0	10	
Cobalt	<0.0150	0.0250	0	0				0	10	
Iron	0.185	0.500	0	0.186				0.629	10	
Lead	<0.00150	0.00500	0	0				0	10	
Lithium	0.0477	0.0500	0	0.0462				3.27	10	
Magnesium	12.2	1.50	0	12.2				0.282	10	
Molybdenum	<0.0100	0.0250	0	0				0	10	
Potassium	1.83	1.50	0	2.08				12.6	10	R
Selenium	<0.0100	0.0250	0	0				0	10	
Sodium	53.2	1.50	0	51.9				2.54	10	
Thallium	<0.00250	0.00750	0	0				0	10	

Qualifiers: B Analyte detected in the associated Method Blank DF Dilution Factor
J Analyte detected between MDL and RL MDL Method Detection Limit
ND Not Detected at the Method Detection Limit R RPD outside accepted control limits
RL Reporting Limit S Spike Recovery outside control limits
J Analyte detected between SDL and RL N Parameter not NELAP certified

CLIENT: Golder
Work Order: 1905167
Project: Luminant-MLSES Ash Ponds

ANALYTICAL QC SUMMARY REPORT

RunID: ICP-MS5_190521A

Sample ID: 1905218-06A PDS	Batch ID: 90990	TestNo: SW6020A	Units: mg/L
SampType: PDS	Run ID: ICP-MS5_190521A	Analysis Date: 5/21/2019 3:44:00 PM	Prep Date: 5/20/2019

Analyte	Result	RL	SPK value	Ref Val	%REC	LowLimit	HighLimit	%RPD	RPDLimit	Qual
Antimony	0.192	0.00250	0.200	0	96.2	80	120			
Arsenic	0.183	0.00500	0.200	0	91.7	80	120			
Barium	0.237	0.0100	0.200	0.0510	92.9	80	120			
Beryllium	0.179	0.00100	0.200	0	89.3	80	120			
Cadmium	0.194	0.00100	0.200	0	97.0	80	120			
Calcium	26.2	0.300	5.00	23.8	48.1	80	120			S
Chromium	0.198	0.00500	0.200	0	98.8	80	120			
Cobalt	0.191	0.00500	0.200	0	95.6	80	120			
Iron	5.16	0.100	5.00	0.186	99.5	80	120			
Lead	0.190	0.00100	0.200	0	94.8	80	120			
Lithium	0.238	0.0100	0.200	0.0462	96.1	80	120			
Magnesium	15.8	0.300	5.00	12.2	72.5	80	120			S
Molybdenum	0.179	0.00500	0.200	0	89.4	80	120			
Potassium	6.49	0.300	5.00	2.08	88.3	80	120			
Selenium	0.178	0.00500	0.200	0	89.1	80	120			
Sodium	51.5	0.300	5.00	51.9	-7.46	80	120			S
Thallium	0.189	0.00150	0.200	0	94.5	80	120			

Sample ID: 1905218-06A MS	Batch ID: 90990	TestNo: SW6020A	Units: mg/L
SampType: MS	Run ID: ICP-MS5_190521A	Analysis Date: 5/21/2019 3:46:00 PM	Prep Date: 5/20/2019

Analyte	Result	RL	SPK value	Ref Val	%REC	LowLimit	HighLimit	%RPD	RPDLimit	Qual
Antimony	0.196	0.00250	0.200	0	98.1	80	120			
Arsenic	0.189	0.00500	0.200	0	94.4	80	120			
Barium	0.244	0.0100	0.200	0.0510	96.3	80	120			
Beryllium	0.183	0.00100	0.200	0	91.6	80	120			
Cadmium	0.196	0.00100	0.200	0	98.0	80	120			
Calcium	27.3	0.300	5.00	23.8	69.1	80	120			S
Chromium	0.197	0.00500	0.200	0	98.5	80	120			
Cobalt	0.194	0.00500	0.200	0	96.9	80	120			
Iron	5.24	0.100	5.00	0.186	101	80	120			
Lead	0.193	0.00100	0.200	0	96.5	80	120			
Lithium	0.241	0.0100	0.200	0.0462	97.6	80	120			
Magnesium	16.6	0.300	5.00	12.2	89.7	80	120			
Molybdenum	0.189	0.00500	0.200	0	94.4	80	120			
Potassium	6.74	0.300	5.00	2.08	93.2	80	120			
Selenium	0.183	0.00500	0.200	0	91.3	80	120			
Sodium	53.9	0.300	5.00	51.9	39.6	80	120			S
Thallium	0.192	0.00150	0.200	0	95.8	80	120			

Qualifiers: B Analyte detected in the associated Method Blank DF Dilution Factor
J Analyte detected between MDL and RL MDL Method Detection Limit
ND Not Detected at the Method Detection Limit R RPD outside accepted control limits
RL Reporting Limit S Spike Recovery outside control limits
J Analyte detected between SDL and RL N Parameter not NELAP certified

CLIENT: Golder
Work Order: 1905167
Project: Luminant-MLSES Ash Ponds

ANALYTICAL QC SUMMARY REPORT

RunID: ICP-MS5_190521A

Sample ID: 1905218-06A MSD	Batch ID: 90990	TestNo: SW6020A	Units: mg/L
SampType: MSD	Run ID: ICP-MS5_190521A	Analysis Date: 5/21/2019 3:49:00 PM	Prep Date: 5/20/2019

Analyte	Result	RL	SPK value	Ref Val	%REC	LowLimit	HighLimit	%RPD	RPDLimit	Qual
Antimony	0.199	0.00250	0.200	0	99.3	80	120	1.17	15	
Arsenic	0.189	0.00500	0.200	0	94.3	80	120	0.111	15	
Barium	0.246	0.0100	0.200	0.0510	97.3	80	120	0.778	15	
Beryllium	0.181	0.00100	0.200	0	90.4	80	120	1.36	15	
Cadmium	0.197	0.00100	0.200	0	98.7	80	120	0.775	15	
Calcium	27.4	0.300	5.00	23.8	72.7	80	120	0.665	15	S
Chromium	0.198	0.00500	0.200	0	99.1	80	120	0.607	15	
Cobalt	0.196	0.00500	0.200	0	97.8	80	120	0.893	15	
Iron	5.30	0.100	5.00	0.186	102	80	120	1.09	15	
Lead	0.192	0.00100	0.200	0	96.1	80	120	0.414	15	
Lithium	0.238	0.0100	0.200	0.0462	96.0	80	120	1.33	15	
Magnesium	16.8	0.300	5.00	12.2	92.6	80	120	0.883	15	
Molybdenum	0.191	0.00500	0.200	0	95.7	80	120	1.34	15	
Potassium	6.80	0.300	5.00	2.08	94.5	80	120	0.968	15	
Selenium	0.183	0.00500	0.200	0	91.7	80	120	0.351	15	
Sodium	54.6	0.300	5.00	51.9	54.2	80	120	1.35	15	S
Thallium	0.192	0.00150	0.200	0	96.0	80	120	0.248	15	

LUMINANT

Qualifiers: B Analyte detected in the associated Method Blank J Analyte detected between MDL and RL ND Not Detected at the Method Detection Limit RL Reporting Limit J Analyte detected between SDL and RL	DF Dilution Factor MDL Method Detection Limit R RPD outside accepted control limits S Spike Recovery outside control limits N Parameter not NELAP certified
--	---

CLIENT: Golder
Work Order: 1905167
Project: Luminant-MLSES Ash Ponds

ANALYTICAL QC SUMMARY REPORT

RunID: ICP-MS5_190521A

Sample ID ICV-190521	Batch ID: R104204	TestNo: SW6020A	Units: mg/L
SampType: ICV	Run ID: ICP-MS5_190521A	Analysis Date: 5/21/2019 12:10:00 PM	Prep Date:

Analyte	Result	RL	SPK value	Ref Val	%REC	LowLimit	HighLimit	%RPD	RPDLimit	Qual
Antimony	0.102	0.00250	0.100	0	102	90	110			
Arsenic	0.103	0.00500	0.100	0	103	90	110			
Barium	0.0990	0.0100	0.100	0	99.0	90	110			
Beryllium	0.0972	0.00100	0.100	0	97.2	90	110			
Cadmium	0.102	0.00100	0.100	0	102	90	110			
Calcium	2.52	0.300	2.50	0	101	90	110			
Chromium	0.103	0.00500	0.100	0	103	90	110			
Cobalt	0.108	0.00500	0.100	0	108	90	110			
Iron	2.60	0.100	2.50	0	104	90	110			
Lead	0.0982	0.00100	0.100	0	98.2	90	110			
Lithium	0.103	0.0100	0.100	0	103	90	110			
Magnesium	2.49	0.300	2.50	0	99.7	90	110			
Molybdenum	0.0930	0.00500	0.100	0	93.0	90	110			
Potassium	2.38	0.300	2.50	0	95.3	90	110			
Selenium	0.104	0.00500	0.100	0	104	90	110			
Sodium	2.56	0.300	2.50	0	103	90	110			
Thallium	0.0977	0.00150	0.100	0	97.7	90	110			

Sample ID LCVL-190521	Batch ID: R104204	TestNo: SW6020A	Units: mg/L
SampType: LCVL	Run ID: ICP-MS5_190521A	Analysis Date: 5/21/2019 12:15:00 PM	Prep Date:

Analyte	Result	RL	SPK value	Ref Val	%REC	LowLimit	HighLimit	%RPD	RPDLimit	Qual
Antimony	0.00183	0.00250	0.00200	0	91.4	70	130			
Arsenic	0.00504	0.00500	0.00500	0	101	70	130			
Barium	0.00459	0.0100	0.00500	0	91.8	70	130			
Beryllium	0.000968	0.00100	0.00100	0	96.8	70	130			
Cadmium	0.00106	0.00100	0.00100	0	106	70	130			
Calcium	0.104	0.300	0.100	0	104	70	130			
Chromium	0.00482	0.00500	0.00500	0	96.4	70	130			
Cobalt	0.00494	0.00500	0.00500	0	98.7	70	130			
Iron	0.0979	0.100	0.100	0	97.9	70	130			
Lead	0.000882	0.00100	0.00100	0	88.2	70	130			
Lithium	0.00996	0.0100	0.0100	0	99.6	70	130			
Magnesium	0.0983	0.300	0.100	0	98.3	70	130			
Molybdenum	0.00464	0.00500	0.00500	0	92.8	70	130			
Potassium	0.0691	0.300	0.100	0	69.1	70	130			S
Selenium	0.00633	0.00500	0.00500	0	127	70	130			
Sodium	0.0960	0.300	0.100	0	96.0	70	130			
Thallium	0.000944	0.00150	0.00100	0	94.4	70	130			

Qualifiers: B Analyte detected in the associated Method Blank DF Dilution Factor
J Analyte detected between MDL and RL MDL Method Detection Limit
ND Not Detected at the Method Detection Limit R RPD outside accepted control limits
RL Reporting Limit S Spike Recovery outside control limits
J Analyte detected between SDL and RL N Parameter not NELAP certified

CLIENT: Golder
 Work Order: 1905167
 Project: Luminant-MLSES Ash Ponds

ANALYTICAL QC SUMMARY REPORT

RunID: ICP-MS5_190521A

Sample ID: CCV4-190521	Batch ID: R104204	TestNo: SW6020A	Units: mg/L
SampType: CCV	Run ID: ICP-MS5_190521A	Analysis Date: 5/21/2019 3:00:00 PM	Prep Date:

Analyte	Result	RL	SPK value	Ref Val	%REC	LowLimit	HighLimit	%RPD	RPDLimit	Qual
Antimony	0.203	0.00250	0.200	0	101	90	110			
Arsenic	0.203	0.00500	0.200	0	102	90	110			
Barium	0.202	0.0100	0.200	0	101	90	110			
Beryllium	0.192	0.00100	0.200	0	95.9	90	110			
Cadmium	0.204	0.00100	0.200	0	102	90	110			
Calcium	4.96	0.300	5.00	0	99.3	90	110			
Chromium	0.203	0.00500	0.200	0	101	90	110			
Cobalt	0.213	0.00500	0.200	0	106	90	110			
Iron	5.15	0.100	5.00	0	103	90	110			
Lead	0.198	0.00100	0.200	0	98.8	90	110			
Lithium	0.205	0.0100	0.200	0	103	90	110			
Magnesium	5.15	0.300	5.00	0	103	90	110			
Molybdenum	0.199	0.00500	0.200	0	99.7	90	110			
Potassium	4.83	0.300	5.00	0	96.6	90	110			
Selenium	0.200	0.00500	0.200	0	100	90	110			
Sodium	5.26	0.300	5.00	0	105	90	110			
Thallium	0.197	0.00150	0.200	0	98.4	90	110			

Sample ID: LCVL4-190521	Batch ID: R104204	TestNo: SW6020A	Units: mg/L
SampType: LCVL	Run ID: ICP-MS5_190521A	Analysis Date: 5/21/2019 3:05:00 PM	Prep Date:

Analyte	Result	RL	SPK value	Ref Val	%REC	LowLimit	HighLimit	%RPD	RPDLimit	Qual
Antimony	0.00207	0.00250	0.00200	0	104	70	130			
Arsenic	0.00491	0.00500	0.00500	0	98.1	70	130			
Barium	0.00487	0.0100	0.00500	0	97.5	70	130			
Beryllium	0.000934	0.00100	0.00100	0	93.4	70	130			
Cadmium	0.00104	0.00100	0.00100	0	104	70	130			
Calcium	0.0913	0.300	0.100	0	91.3	70	130			
Chromium	0.00486	0.00500	0.00500	0	97.1	70	130			
Cobalt	0.00525	0.00500	0.00500	0	105	70	130			
Iron	0.101	0.100	0.100	0	101	70	130			
Lead	0.000868	0.00100	0.00100	0	86.8	70	130			
Lithium	0.0102	0.0100	0.0100	0	102	70	130			
Magnesium	0.104	0.300	0.100	0	104	70	130			
Molybdenum	0.00483	0.00500	0.00500	0	96.6	70	130			
Potassium	0.0524	0.300	0.100	0	52.4	70	130			S
Selenium	0.00506	0.00500	0.00500	0	101	70	130			
Sodium	0.144	0.300	0.100	0	144	70	130			S
Thallium	0.000962	0.00150	0.00100	0	96.2	70	130			

Qualifiers:

B	Analyte detected in the associated Method Blank	DF	Dilution Factor
J	Analyte detected between MDL and RL	MDL	Method Detection Limit
ND	Not Detected at the Method Detection Limit	R	RPD outside accepted control limits
RL	Reporting Limit	S	Spike Recovery outside control limits
J	Analyte detected between SDL and RL	N	Parameter not NELAP certified

CLIENT: Golder
 Work Order: 1905167
 Project: Luminant-MLSES Ash Ponds

ANALYTICAL QC SUMMARY REPORT

RunID: ICP-MS5_190521A

Sample ID: CCV5-190521	Batch ID: R104204	TestNo: SW6020A	Units: mg/L
SampType: CCV	Run ID: ICP-MS5_190521A	Analysis Date: 5/21/2019 3:51:00 PM	Prep Date:

Analyte	Result	RL	SPK value	Ref Val	%REC	LowLimit	HighLimit	%RPD	RPDLimit	Qual
Antimony	0.197	0.00250	0.200	0	98.5	90	110			
Arsenic	0.199	0.00500	0.200	0	99.7	90	110			
Barium	0.194	0.0100	0.200	0	96.8	90	110			
Beryllium	0.181	0.00100	0.200	0	90.6	90	110			
Cadmium	0.197	0.00100	0.200	0	98.4	90	110			
Calcium	4.83	0.300	5.00	0	96.7	90	110			
Chromium	0.199	0.00500	0.200	0	99.4	90	110			
Cobalt	0.207	0.00500	0.200	0	104	90	110			
Iron	5.09	0.100	5.00	0	102	90	110			
Lead	0.192	0.00100	0.200	0	96.2	90	110			
Lithium	0.198	0.0100	0.200	0	99.0	90	110			
Magnesium	5.01	0.300	5.00	0	100	90	110			
Molybdenum	0.192	0.00500	0.200	0	95.8	90	110			
Potassium	4.71	0.300	5.00	0	94.2	90	110			
Selenium	0.200	0.00500	0.200	0	99.8	90	110			
Sodium	5.09	0.300	5.00	0	102	90	110			
Thallium	0.192	0.00150	0.200	0	95.8	90	110			

Sample ID: LCVL5-190521	Batch ID: R104204	TestNo: SW6020A	Units: mg/L
SampType: LCVL	Run ID: ICP-MS5_190521A	Analysis Date: 5/21/2019 3:55:00 PM	Prep Date:

Analyte	Result	RL	SPK value	Ref Val	%REC	LowLimit	HighLimit	%RPD	RPDLimit	Qual
Antimony	0.00208	0.00250	0.00200	0	104	70	130			
Arsenic	0.00481	0.00500	0.00500	0	96.1	70	130			
Barium	0.00469	0.0100	0.00500	0	93.8	70	130			
Beryllium	0.000861	0.00100	0.00100	0	86.1	70	130			
Cadmium	0.000998	0.00100	0.00100	0	99.8	70	130			
Calcium	0.102	0.300	0.100	0	102	70	130			
Chromium	0.00463	0.00500	0.00500	0	92.5	70	130			
Cobalt	0.00508	0.00500	0.00500	0	102	70	130			
Iron	0.0987	0.100	0.100	0	98.7	70	130			
Lead	0.000837	0.00100	0.00100	0	83.7	70	130			
Lithium	0.00978	0.0100	0.0100	0	97.8	70	130			
Magnesium	0.0989	0.300	0.100	0	98.9	70	130			
Molybdenum	0.00479	0.00500	0.00500	0	95.8	70	130			
Potassium	0.0352	0.300	0.100	0	35.2	70	130			S
Selenium	0.00485	0.00500	0.00500	0	97.0	70	130			
Sodium	0.135	0.300	0.100	0	135	70	130			S
Thallium	0.000929	0.00150	0.00100	0	92.9	70	130			

Qualifiers:

B	Analyte detected in the associated Method Blank	DF	Dilution Factor
J	Analyte detected between MDL and RL	MDL	Method Detection Limit
ND	Not Detected at the Method Detection Limit	R	RPD outside accepted control limits
RL	Reporting Limit	S	Spike Recovery outside control limits
J	Analyte detected between SDL and RL	N	Parameter not NELAP certified

CLIENT: Golder
Work Order: 1905167
Project: Luminant-MLSES Ash Ponds

ANALYTICAL QC SUMMARY REPORT

RunID: IC2_190515A

The QC data in batch 90908 applies to the following samples: 1905167-01C, 1905167-02C

Sample ID: MB-90908	Batch ID: 90908	TestNo: E300	Units: mg/L
SampType: MBLK	Run ID: IC2_190515A	Analysis Date: 5/15/2019 10:10:50 AM	Prep Date: 5/15/2019

Analyte	Result	RL	SPK value	Ref Val	%REC	LowLimit	HighLimit	%RPD	RPDLimit	Qual
Chloride	<0.300	1.00								
Fluoride	<0.100	0.400								
Nitrate-N	<0.100	0.500								
Sulfate	<1.00	3.00								

Sample ID: LCS-90908	Batch ID: 90908	TestNo: E300	Units: mg/L
SampType: LCS	Run ID: IC2_190515A	Analysis Date: 5/15/2019 10:26:50 AM	Prep Date: 5/15/2019

Analyte	Result	RL	SPK value	Ref Val	%REC	LowLimit	HighLimit	%RPD	RPDLimit	Qual
Chloride	10.1	1.00	10.00	0	101	90	110			
Fluoride	4.00	0.400	4.000	0	99.9	90	110			
Nitrate-N	5.09	0.500	5.000	0	102	90	110			
Sulfate	30.4	3.00	30.00	0	101	90	110			

Sample ID: LCSD-90908	Batch ID: 90908	TestNo: E300	Units: mg/L
SampType: LCSD	Run ID: IC2_190515A	Analysis Date: 5/15/2019 10:42:50 AM	Prep Date: 5/15/2019

Analyte	Result	RL	SPK value	Ref Val	%REC	LowLimit	HighLimit	%RPD	RPDLimit	Qual
Chloride	10.2	1.00	10.00	0	102	90	110	0.674	20	
Fluoride	4.05	0.400	4.000	0	101	90	110	1.26	20	
Nitrate-N	5.08	0.500	5.000	0	102	90	110	0.146	20	
Sulfate	30.9	3.00	30.00	0	103	90	110	1.55	20	

Sample ID: 1905167-01CMS	Batch ID: 90908	TestNo: E300	Units: mg/L
SampType: MS	Run ID: IC2_190515A	Analysis Date: 5/15/2019 1:07:36 PM	Prep Date: 5/15/2019

Analyte	Result	RL	SPK value	Ref Val	%REC	LowLimit	HighLimit	%RPD	RPDLimit	Qual
Chloride	222	10.0	200.0	12.69	105	90	110			
Fluoride	211	4.00	200.0	0	106	90	110			
Nitrate-N	45.6	5.00	45.16	0	101	90	110			
Sulfate	239	30.0	200.0	41.32	98.7	90	110			

Sample ID: 1905167-01CMSD	Batch ID: 90908	TestNo: E300	Units: mg/L
SampType: MSD	Run ID: IC2_190515A	Analysis Date: 5/15/2019 1:23:36 PM	Prep Date: 5/15/2019

Analyte	Result	RL	SPK value	Ref Val	%REC	LowLimit	HighLimit	%RPD	RPDLimit	Qual
Chloride	221	10.0	200.0	12.69	104	90	110	0.308	20	
Fluoride	210	4.00	200.0	0	105	90	110	0.286	20	
Nitrate-N	45.8	5.00	45.16	0	101	90	110	0.495	20	
Sulfate	237	30.0	200.0	41.32	97.7	90	110	0.821	20	

Qualifiers:

B	Analyte detected in the associated Method Blank	DF	Dilution Factor
J	Analyte detected between MDL and RL	MDL	Method Detection Limit
ND	Not Detected at the Method Detection Limit	R	RPD outside accepted control limits
RL	Reporting Limit	S	Spike Recovery outside control limits
J	Analyte detected between SDL and RL	N	Parameter not NELAP certified

CLIENT: Golder
Work Order: 1905167
Project: Luminant-MLSES Ash Ponds

ANALYTICAL QC SUMMARY REPORT

RunID: IC2_190515A

Sample ID: 1905167-02CMS	Batch ID: 90908	TestNo: E300	Units: mg/L							
SampType: MS	Run ID: IC2_190515A	Analysis Date: 5/15/2019 1:55:36 PM	Prep Date: 5/15/2019							
Analyte	Result	RL	SPK value	Ref Val	%REC	LowLimit	HighLimit	%RPD	RPDLimit	Qual
Chloride	686	10.0	200.0	528.8	78.8	90	110			S
Fluoride	229	4.00	200.0	24.26	102	90	110			
Nitrate-N	56.2	5.00	45.16	10.55	101	90	110			
Sulfate	2520	30.0	200.0	0	1260	90	110			S

Sample ID: 1905167-02CMSD	Batch ID: 90908	TestNo: E300	Units: mg/L							
SampType: MSD	Run ID: IC2_190515A	Analysis Date: 5/15/2019 2:11:36 PM	Prep Date: 5/15/2019							
Analyte	Result	RL	SPK value	Ref Val	%REC	LowLimit	HighLimit	%RPD	RPDLimit	Qual
Chloride	688	10.0	200.0	528.8	79.8	90	110	0.292	20	S
Fluoride	229	4.00	200.0	24.26	102	90	110	0.251	20	
Nitrate-N	57.3	5.00	45.16	10.55	103	90	110	1.85	20	
Sulfate	<10.0	30.0	200.0	0	0	90	110	0	20	S

LUMINANT

Qualifiers: B Analyte detected in the associated Method Blank DF Dilution Factor
 J Analyte detected between MDL and RL MDL Method Detection Limit
 ND Not Detected at the Method Detection Limit R RPD outside accepted control limits
 RL Reporting Limit S Spike Recovery outside control limits
 J Analyte detected between SDL and RL N Parameter not NELAP certified

CLIENT: Golder
Work Order: 1905167
Project: Luminant-MLSES Ash Ponds

ANALYTICAL QC SUMMARY REPORT

RunID: IC2_190515A

Sample ID ICV-190515	Batch ID: R104097	TestNo: E300	Units: mg/L							
SampType: ICV	Run ID: IC2_190515A	Analysis Date: 5/15/2019 9:38:50 AM	Prep Date:							
Analyte	Result	RL	SPK value	Ref Val	%REC	LowLimit	HighLimit	%RPD	RPDLimit	Qual
Chloride	25.8	1.00	25.00	0	103	90	110			
Fluoride	10.3	0.400	10.00	0	103	90	110			
Nitrate-N	13.0	0.500	12.50	0	104	90	110			
Sulfate	77.8	3.00	75.00	0	104	90	110			

Sample ID CCV1-190515	Batch ID: R104097	TestNo: E300	Units: mg/L							
SampType: CCV	Run ID: IC2_190515A	Analysis Date: 5/15/2019 4:51:36 PM	Prep Date:							
Analyte	Result	RL	SPK value	Ref Val	%REC	LowLimit	HighLimit	%RPD	RPDLimit	Qual
Chloride	10.4	1.00	10.00	0	104	90	110			
Fluoride	4.15	0.400	4.000	0	104	90	110			
Nitrate-N	5.13	0.500	5.000	0	103	90	110			
Sulfate	30.8	3.00	30.00	0	103	90	110			

Sample ID CCV2-190515	Batch ID: R104097	TestNo: E300	Units: mg/L							
SampType: CCV	Run ID: IC2_190515A	Analysis Date: 5/15/2019 8:35:35 PM	Prep Date:							
Analyte	Result	RL	SPK value	Ref Val	%REC	LowLimit	HighLimit	%RPD	RPDLimit	Qual
Chloride	10.6	1.00	10.00	0	106	90	110			
Fluoride	4.20	0.400	4.000	0	105	90	110			
Nitrate-N	5.20	0.500	5.000	0	104	90	110			
Sulfate	31.5	3.00	30.00	0	105	90	110			

Qualifiers:

B	Analyte detected in the associated Method Blank	DF	Dilution Factor
J	Analyte detected between MDL and RL	MDL	Method Detection Limit
ND	Not Detected at the Method Detection Limit	R	RPD outside accepted control limits
RL	Reporting Limit	S	Spike Recovery outside control limits
J	Analyte detected between SDL and RL	N	Parameter not NELAP certified

CLIENT: Golder
Work Order: 1905167
Project: Luminant-MLSES Ash Ponds

ANALYTICAL QC SUMMARY REPORT

RunID: IC4_190516A

The QC data in batch 90935 applies to the following samples: 1905167-02C

Sample ID MB-90935	Batch ID: 90935	TestNo: E300	Units: mg/L							
SampType: MBLK	Run ID: IC4_190516A	Analysis Date: 5/16/2019 10:26:21 AM	Prep Date: 5/16/2019							
Analyte	Result	RL	SPK value	Ref Val	%REC	LowLimit	HighLimit	%RPD	RPDLimit	Qual
Chloride	<0.300	1.00								
Sulfate	<1.00	3.00								

Sample ID LCS-90935	Batch ID: 90935	TestNo: E300	Units: mg/L							
SampType: LCS	Run ID: IC4_190516A	Analysis Date: 5/16/2019 10:42:21 AM	Prep Date: 5/16/2019							
Analyte	Result	RL	SPK value	Ref Val	%REC	LowLimit	HighLimit	%RPD	RPDLimit	Qual
Chloride	9.61	1.00	10.00	0	96.1	90	110			
Sulfate	29.5	3.00	30.00	0	98.3	90	110			

Sample ID LCSD-90935	Batch ID: 90935	TestNo: E300	Units: mg/L							
SampType: LCSD	Run ID: IC4_190516A	Analysis Date: 5/16/2019 10:58:21 AM	Prep Date: 5/16/2019							
Analyte	Result	RL	SPK value	Ref Val	%REC	LowLimit	HighLimit	%RPD	RPDLimit	Qual
Chloride	9.68	1.00	10.00	0	96.8	90	110	0.745	20	
Sulfate	29.8	3.00	30.00	0	99.2	90	110	0.935	20	

Sample ID 1905167-02CMS	Batch ID: 90935	TestNo: E300	Units: mg/L							
SampType: MS	Run ID: IC4_190516A	Analysis Date: 5/16/2019 5:10:27 PM	Prep Date: 5/16/2019							
Analyte	Result	RL	SPK value	Ref Val	%REC	LowLimit	HighLimit	%RPD	RPDLimit	Qual
Chloride	2490	100	2000	512.8	98.6	90	110			
Sulfate	4830	300	2000	2897	96.9	90	110			

Sample ID 1905167-02CMSD	Batch ID: 90935	TestNo: E300	Units: mg/L							
SampType: MSD	Run ID: IC4_190516A	Analysis Date: 5/16/2019 5:26:27 PM	Prep Date: 5/16/2019							
Analyte	Result	RL	SPK value	Ref Val	%REC	LowLimit	HighLimit	%RPD	RPDLimit	Qual
Chloride	2500	100	2000	512.8	99.4	90	110	0.622	20	
Sulfate	4880	300	2000	2897	99.1	90	110	0.920	20	

Sample ID 1905168-01CMS	Batch ID: 90935	TestNo: E300	Units: mg/L							
SampType: MS	Run ID: IC4_190516A	Analysis Date: 5/16/2019 5:58:26 PM	Prep Date: 5/16/2019							
Analyte	Result	RL	SPK value	Ref Val	%REC	LowLimit	HighLimit	%RPD	RPDLimit	Qual
Chloride	2170	100	2000	212.8	98.1	90	110			
Sulfate	4380	300	2000	2468	95.6	90	110			

Qualifiers: B Analyte detected in the associated Method Blank DF Dilution Factor
J Analyte detected between MDL and RL MDL Method Detection Limit
ND Not Detected at the Method Detection Limit R RPD outside accepted control limits
RL Reporting Limit S Spike Recovery outside control limits
J Analyte detected between SDL and RL N Parameter not NELAP certified

CLIENT: Golder
Work Order: 1905167
Project: Luminant-MLSES Ash Ponds

ANALYTICAL QC SUMMARY REPORT

RunID: IC4_190516A

Sample ID	1905168-01CMSD	Batch ID:	90935	TestNo:	E300	Units:	mg/L			
SampType:	MSD	Run ID:	IC4_190516A	Analysis Date:	5/16/2019 6:14:27 PM	Prep Date:	5/16/2019			
Analyte	Result	RL	SPK value	Ref Val	%REC	LowLimit	HighLimit	%RPD	RPDLimit	Qual
Chloride	2170	100	2000	212.8	97.8	90	110	0.235	20	
Sulfate	4390	300	2000	2468	96.2	90	110	0.273	20	

LUMINANT

Qualifiers: B Analyte detected in the associated Method Blank J Analyte detected between MDL and RL ND Not Detected at the Method Detection Limit RL Reporting Limit J Analyte detected between SDL and RL	DF Dilution Factor MDL Method Detection Limit R RPD outside accepted control limits S Spike Recovery outside control limits N Parameter not NELAP certified
--	---

CLIENT: Golder
Work Order: 1905167
Project: Luminant-MLSES Ash Ponds

ANALYTICAL QC SUMMARY REPORT

RunID: IC4_190516A

Sample ID ICV-190516	Batch ID: R104119	TestNo: E300	Units: mg/L							
SampType: ICV	Run ID: IC4_190516A	Analysis Date: 5/16/2019 9:54:21 AM	Prep Date:							
Analyte	Result	RL	SPK value	Ref Val	%REC	LowLimit	HighLimit	%RPD	RPDLimit	Qual
Chloride	24.7	1.00	25.00	0	99.0	90	110			
Sulfate	74.5	3.00	75.00	0	99.4	90	110			

Sample ID CCV1-190516	Batch ID: R104119	TestNo: E300	Units: mg/L							
SampType: CCV	Run ID: IC4_190516A	Analysis Date: 5/16/2019 9:10:26 PM	Prep Date:							
Analyte	Result	RL	SPK value	Ref Val	%REC	LowLimit	HighLimit	%RPD	RPDLimit	Qual
Chloride	9.75	1.00	10.00	0	97.5	90	110			
Sulfate	30.2	3.00	30.00	0	101	90	110			

LUMINANT

Qualifiers:	<p>B Analyte detected in the associated Method Blank</p> <p>J Analyte detected between MDL and RL</p> <p>ND Not Detected at the Method Detection Limit</p> <p>RL Reporting Limit</p> <p>J Analyte detected between SDL and RL</p>	<p>DF Dilution Factor</p> <p>MDL Method Detection Limit</p> <p>R RPD outside accepted control limits</p> <p>S Spike Recovery outside control limits</p> <p>N Parameter not NELAP certified</p>
--------------------	---	--

CLIENT: Golder
Work Order: 1905167
Project: Luminant-MLSES Ash Ponds

ANALYTICAL QC SUMMARY REPORT

RunID: TITRATOR_190516A

The QC data in batch 90940 applies to the following samples: 1905167-01C, 1905167-02C

Sample ID: MB-90940	Batch ID: 90940	TestNo: M2320 B	Units: mg/L @ pH 4.47
SampType: MBLK	Run ID: TITRATOR_190516A	Analysis Date: 5/16/2019 2:00:00 PM	Prep Date: 5/16/2019

Analyte	Result	RL	SPK value	Ref Val	%REC	LowLimit	HighLimit	%RPD	RPDLimit	Qual
Alkalinity, Bicarbonate (As CaCO3)	<10.0	20.0								
Alkalinity, Carbonate (As CaCO3)	<10.0	20.0								
Alkalinity, Hydroxide (As CaCO3)	<10.0	20.0								
Alkalinity, Total (As CaCO3)	<20.0	20.0								

Sample ID: LCS-90940	Batch ID: 90940	TestNo: M2320 B	Units: mg/L @ pH 4.08
SampType: LCS	Run ID: TITRATOR_190516A	Analysis Date: 5/16/2019 2:04:00 PM	Prep Date: 5/16/2019

Analyte	Result	RL	SPK value	Ref Val	%REC	LowLimit	HighLimit	%RPD	RPDLimit	Qual
Alkalinity, Total (As CaCO3)	52.3	20.0	50.00	0	105	74	129			

Sample ID: 1905134-01C DUP	Batch ID: 90940	TestNo: M2320 B	Units: mg/L @ pH 4.52
SampType: DUP	Run ID: TITRATOR_190516A	Analysis Date: 5/16/2019 2:15:00 PM	Prep Date: 5/16/2019

Analyte	Result	RL	SPK value	Ref Val	%REC	LowLimit	HighLimit	%RPD	RPDLimit	Qual
Alkalinity, Bicarbonate (As CaCO3)	205	20.0	0	205.8				0.536	20	
Alkalinity, Carbonate (As CaCO3)	<10.0	20.0	0	0				0	20	
Alkalinity, Hydroxide (As CaCO3)	<10.0	20.0	0	0				0	20	
Alkalinity, Total (As CaCO3)	205	20.0	0	205.8				0.536	20	

Sample ID: 1905168-05C DUP	Batch ID: 90940	TestNo: M2320 B	Units: mg/L @ pH 4.51
SampType: DUP	Run ID: TITRATOR_190516A	Analysis Date: 5/16/2019 4:30:00 PM	Prep Date: 5/16/2019

Analyte	Result	RL	SPK value	Ref Val	%REC	LowLimit	HighLimit	%RPD	RPDLimit	Qual
Alkalinity, Bicarbonate (As CaCO3)	<10.0	20.0	0	0				0	20	
Alkalinity, Carbonate (As CaCO3)	<10.0	20.0	0	0				0	20	
Alkalinity, Hydroxide (As CaCO3)	<10.0	20.0	0	0				0	20	
Alkalinity, Total (As CaCO3)	<20.0	20.0	0	0				0	20	

Qualifiers:

B Analyte detected in the associated Method Blank	DF Dilution Factor
J Analyte detected between MDL and RL	MDL Method Detection Limit
ND Not Detected at the Method Detection Limit	R RPD outside accepted control limits
RL Reporting Limit	S Spike Recovery outside control limits
J Analyte detected between SDL and RL	N Parameter not NELAP certified

CLIENT: Golder
Work Order: 1905167
Project: Luminant-MLSES Ash Ponds

ANALYTICAL QC SUMMARY REPORT

RunID: TITRATOR_190516A

Sample ID ICV-190516	Batch ID: R104124	TestNo: M2320 B	Units: mg/L @ pH 4.34
SampType: ICV	Run ID: TITRATOR_190516A	Analysis Date: 5/16/2019 1:58:00 PM	Prep Date: 5/16/2019

Analyte	Result	RL	SPK value	Ref Val	%REC	LowLimit	HighLimit	%RPD	RPDLimit	Qual
Alkalinity, Bicarbonate (As CaCO3)	8.64	20.0	0							
Alkalinity, Carbonate (As CaCO3)	89.3	20.0	0							
Alkalinity, Hydroxide (As CaCO3)	<10.0	20.0	0							
Alkalinity, Total (As CaCO3)	97.9	20.0	100.0	0	97.9	98	102			

Sample ID CCV1-190516	Batch ID: R104124	TestNo: M2320 B	Units: mg/L @ pH 4.25
SampType: CCV	Run ID: TITRATOR_190516A	Analysis Date: 5/16/2019 3:39:00 PM	Prep Date: 5/16/2019

Analyte	Result	RL	SPK value	Ref Val	%REC	LowLimit	HighLimit	%RPD	RPDLimit	Qual
Alkalinity, Bicarbonate (As CaCO3)	21.7	20.0	0							
Alkalinity, Carbonate (As CaCO3)	76.8	20.0	0							
Alkalinity, Hydroxide (As CaCO3)	<10.0	20.0	0							
Alkalinity, Total (As CaCO3)	98.5	20.0	100.0	0	98.5	90	110			

Sample ID CCV2-190516	Batch ID: R104124	TestNo: M2320 B	Units: mg/L @ pH 4.21
SampType: CCV	Run ID: TITRATOR_190516A	Analysis Date: 5/16/2019 4:35:00 PM	Prep Date: 5/16/2019

Analyte	Result	RL	SPK value	Ref Val	%REC	LowLimit	HighLimit	%RPD	RPDLimit	Qual
Alkalinity, Bicarbonate (As CaCO3)	17.7	20.0	0							
Alkalinity, Carbonate (As CaCO3)	81.3	20.0	0							
Alkalinity, Hydroxide (As CaCO3)	<10.0	20.0	0							
Alkalinity, Total (As CaCO3)	99.0	20.0	100.0	0	99.0	90	110			

Qualifiers:

B	Analyte detected in the associated Method Blank	DF	Dilution Factor
J	Analyte detected between MDL and RL	MDL	Method Detection Limit
ND	Not Detected at the Method Detection Limit	R	RPD outside accepted control limits
RL	Reporting Limit	S	Spike Recovery outside control limits
J	Analyte detected between SDL and RL	N	Parameter not NELAP certified

CLIENT: Golder
Work Order: 1905167
Project: Luminant-MLSES Ash Ponds

ANALYTICAL QC SUMMARY REPORT

RunID: UV/VIS_2_190515B

The QC data in batch 90921 applies to the following samples: 1905167-01C, 1905167-02C

Sample ID MB-90921	Batch ID: 90921	TestNo: M4500-P E	Units: mg/L							
SampType: MBLK	Run ID: UV/VIS_2_190515B	Analysis Date: 5/15/2019 12:42:00 PM	Prep Date: 5/15/2019							
Analyte	Result	RL	SPK value	Ref Val	%REC	LowLimit	HighLimit	%RPD	RPDLimit	Qual

Phosphorus, Total Orthophosphate (As <0.0300 0.100

Sample ID LCS-90921	Batch ID: 90921	TestNo: M4500-P E	Units: mg/L							
SampType: LCS	Run ID: UV/VIS_2_190515B	Analysis Date: 5/15/2019 12:43:00 PM	Prep Date: 5/15/2019							
Analyte	Result	RL	SPK value	Ref Val	%REC	LowLimit	HighLimit	%RPD	RPDLimit	Qual

Phosphorus, Total Orthophosphate (As 0.513 0.100 0.5000 0 103 80 120

Sample ID LCSD-90921	Batch ID: 90921	TestNo: M4500-P E	Units: mg/L							
SampType: LCSD	Run ID: UV/VIS_2_190515B	Analysis Date: 5/15/2019 12:43:00 PM	Prep Date: 5/15/2019							
Analyte	Result	RL	SPK value	Ref Val	%REC	LowLimit	HighLimit	%RPD	RPDLimit	Qual

Phosphorus, Total Orthophosphate (As 0.504 0.100 0.5000 0 101 80 120 1.77 15

Sample ID 1905168-01CMS	Batch ID: 90921	TestNo: M4500-P E	Units: mg/L							
SampType: MS	Run ID: UV/VIS_2_190515B	Analysis Date: 5/15/2019 12:45:00 PM	Prep Date: 5/15/2019							
Analyte	Result	RL	SPK value	Ref Val	%REC	LowLimit	HighLimit	%RPD	RPDLimit	Qual

Phosphorus, Total Orthophosphate (As 0.587 0.100 0.5000 0.07700 102 80 120

Sample ID 1905168-01CMSD	Batch ID: 90921	TestNo: M4500-P E	Units: mg/L							
SampType: MSD	Run ID: UV/VIS_2_190515B	Analysis Date: 5/15/2019 12:45:00 PM	Prep Date: 5/15/2019							
Analyte	Result	RL	SPK value	Ref Val	%REC	LowLimit	HighLimit	%RPD	RPDLimit	Qual

Phosphorus, Total Orthophosphate (As 0.525 0.100 0.5000 0.07700 89.6 80 120 11.2 15

- | | |
|--|---|
| <p>Qualifiers:</p> <ul style="list-style-type: none"> B Analyte detected in the associated Method Blank J Analyte detected between MDL and RL ND Not Detected at the Method Detection Limit RL Reporting Limit J Analyte detected between SDL and RL | <ul style="list-style-type: none"> DF Dilution Factor MDL Method Detection Limit R RPD outside accepted control limits S Spike Recovery outside control limits N Parameter not NELAP certified |
|--|---|

CLIENT: Golder
Work Order: 1905167
Project: Luminant-MLSES Ash Ponds

ANALYTICAL QC SUMMARY REPORT

RunID: UV/VIS_2_190515B

Sample ID ICV-190515	Batch ID: R104071	TestNo: M4500-P E	Units: mg/L							
SampType: ICV	Run ID: UV/VIS_2_190515B	Analysis Date: 5/15/2019 12:41:00 PM	Prep Date:							
Analyte	Result	RL	SPK value	Ref Val	%REC	LowLimit	HighLimit	%RPD	RPDLimit	Qual
Phosphorus, Total Orthophosphate (As	0.204	0.100	0.2000	0	102	85	115			

Sample ID CCV1-190515	Batch ID: R104071	TestNo: M4500-P E	Units: mg/L							
SampType: CCV	Run ID: UV/VIS_2_190515B	Analysis Date: 5/15/2019 12:51:00 PM	Prep Date:							
Analyte	Result	RL	SPK value	Ref Val	%REC	LowLimit	HighLimit	%RPD	RPDLimit	Qual
Phosphorus, Total Orthophosphate (As	0.509	0.100	0.5000	0	102	85	115			

LUMINANT

Qualifiers:	<p>B Analyte detected in the associated Method Blank</p> <p>J Analyte detected between MDL and RL</p> <p>ND Not Detected at the Method Detection Limit</p> <p>RL Reporting Limit</p> <p>J Analyte detected between SDL and RL</p>	<p>DF Dilution Factor</p> <p>MDL Method Detection Limit</p> <p>R RPD outside accepted control limits</p> <p>S Spike Recovery outside control limits</p> <p>N Parameter not NELAP certified</p>
--------------------	---	--

CLIENT: Golder
Work Order: 1905167
Project: Luminant-MLSES Ash Ponds

ANALYTICAL QC SUMMARY REPORT

RunID: UV/VIS_2_190520A

The QC data in batch 91002 applies to the following samples: 1905167-01A, 1905167-02A

Sample ID MB-91002	Batch ID: 91002	TestNo: M3500-Fe D	Units: mg/L							
SampType: MBLK	Run ID: UV/VIS_2_190520A	Analysis Date: 5/20/2019 3:53:00 PM	Prep Date: 5/20/2019							
Analyte	Result	RL	SPK value	Ref Val	%REC	LowLimit	HighLimit	%RPD	RPDLimit	Qual
Iron, Ferrous	<0.0500	0.100								N

Sample ID LCS-91002	Batch ID: 91002	TestNo: M3500-Fe D	Units: mg/L							
SampType: LCS	Run ID: UV/VIS_2_190520A	Analysis Date: 5/20/2019 3:53:00 PM	Prep Date: 5/20/2019							
Analyte	Result	RL	SPK value	Ref Val	%REC	LowLimit	HighLimit	%RPD	RPDLimit	Qual
Iron, Ferrous	0.0888	0.100	0.1000	0	88.8	85	115			N

Sample ID LCSD-91002	Batch ID: 91002	TestNo: M3500-Fe D	Units: mg/L							
SampType: LCSD	Run ID: UV/VIS_2_190520A	Analysis Date: 5/20/2019 3:53:00 PM	Prep Date: 5/20/2019							
Analyte	Result	RL	SPK value	Ref Val	%REC	LowLimit	HighLimit	%RPD	RPDLimit	Qual
Iron, Ferrous	0.0879	0.100	0.1000	0	87.9	85	115	1.05	15	N

Sample ID 1905185-11AMS	Batch ID: 91002	TestNo: M3500-Fe D	Units: mg/L							
SampType: MS	Run ID: UV/VIS_2_190520A	Analysis Date: 5/20/2019 4:03:00 PM	Prep Date: 5/20/2019							
Analyte	Result	RL	SPK value	Ref Val	%REC	LowLimit	HighLimit	%RPD	RPDLimit	Qual
Iron, Ferrous	0.0860	0.100	0.1000	0	86.0	85	115			N

Sample ID 1905185-11AMSD	Batch ID: 91002	TestNo: M3500-Fe D	Units: mg/L							
SampType: MSD	Run ID: UV/VIS_2_190520A	Analysis Date: 5/20/2019 4:03:00 PM	Prep Date: 5/20/2019							
Analyte	Result	RL	SPK value	Ref Val	%REC	LowLimit	HighLimit	%RPD	RPDLimit	Qual
Iron, Ferrous	0.0861	0.100	0.1000	0	86.1	85	115	0.116	15	N

Qualifiers:

B	Analyte detected in the associated Method Blank	DF	Dilution Factor
J	Analyte detected between MDL and RL	MDL	Method Detection Limit
ND	Not Detected at the Method Detection Limit	R	RPD outside accepted control limits
RL	Reporting Limit	S	Spike Recovery outside control limits
J	Analyte detected between SDL and RL	N	Parameter not NELAP certified

CLIENT: Golder
Work Order: 1905167
Project: Luminant-MLSES Ash Ponds

ANALYTICAL QC SUMMARY REPORT

RunID: UV/VIS_2_190520A

Sample ID ICV-190520	Batch ID: R104177	TestNo: M3500-Fe D	Units: mg/L							
SampType: ICV	Run ID: UV/VIS_2_190520A	Analysis Date: 5/20/2019 3:52:00 PM	Prep Date:							
Analyte	Result	RL	SPK value	Ref Val	%REC	LowLimit	HighLimit	%RPD	RPDLimit	Qual
Iron, Ferrous	0.0875	0.100	0.1000	0	87.5	85	115			N

Sample ID CCV1-190520	Batch ID: R104177	TestNo: M3500-Fe D	Units: mg/L							
SampType: CCV	Run ID: UV/VIS_2_190520A	Analysis Date: 5/20/2019 3:59:00 PM	Prep Date:							
Analyte	Result	RL	SPK value	Ref Val	%REC	LowLimit	HighLimit	%RPD	RPDLimit	Qual
Iron, Ferrous	0.197	0.100	0.2000	0	98.4	85	115			N

Sample ID CCV2-190520	Batch ID: R104177	TestNo: M3500-Fe D	Units: mg/L							
SampType: CCV	Run ID: UV/VIS_2_190520A	Analysis Date: 5/20/2019 4:12:00 PM	Prep Date:							
Analyte	Result	RL	SPK value	Ref Val	%REC	LowLimit	HighLimit	%RPD	RPDLimit	Qual
Iron, Ferrous	0.183	0.100	0.2000	0	91.7	85	115			N

LUMINANT

<p>Qualifiers:</p> <p>B Analyte detected in the associated Method Blank</p> <p>J Analyte detected between MDL and RL</p> <p>ND Not Detected at the Method Detection Limit</p> <p>RL Reporting Limit</p> <p>J Analyte detected between SDL and RL</p>	<p>DF Dilution Factor</p> <p>MDL Method Detection Limit</p> <p>R RPD outside accepted control limits</p> <p>S Spike Recovery outside control limits</p> <p>N Parameter not NELAP certified</p>
---	--

CLIENT: Golder
Work Order: 1905167
Project: Luminant-MLSES Ash Ponds

ANALYTICAL QC SUMMARY REPORT

RunID: WC_190517D

The QC data in batch 90953 applies to the following samples: 1905167-01C, 1905167-02C

Sample ID MB-90953	Batch ID: 90953	TestNo: M2540C	Units: mg/L								
SampType: MBLK	Run ID: WC_190517D	Analysis Date: 5/17/2019 11:40:00 AM	Prep Date: 5/16/2019								
Analyte	Result	RL	SPK value	Ref Val	%REC	LowLimit	HighLimit	%RPD	RPDLimit	Qual	
Total Dissolved Solids (Residue, Filtera		<10.0	10.0								

Sample ID LCS-90953	Batch ID: 90953	TestNo: M2540C	Units: mg/L							
SampType: LCS	Run ID: WC_190517D	Analysis Date: 5/17/2019 11:40:00 AM	Prep Date: 5/16/2019							
Analyte	Result	RL	SPK value	Ref Val	%REC	LowLimit	HighLimit	%RPD	RPDLimit	Qual
Total Dissolved Solids (Residue, Filtera		745	10.0	745.6	0	99.9	90	113		

Sample ID 1905167-02C-DUP	Batch ID: 90953	TestNo: M2540C	Units: mg/L							
SampType: DUP	Run ID: WC_190517D	Analysis Date: 5/17/2019 11:40:00 AM	Prep Date: 5/16/2019							
Analyte	Result	RL	SPK value	Ref Val	%REC	LowLimit	HighLimit	%RPD	RPDLimit	Qual
Total Dissolved Solids (Residue, Filtera		5340	50.0	0	5375			0.747	5	

Sample ID 1905168-02C-DUP	Batch ID: 90953	TestNo: M2540C	Units: mg/L							
SampType: DUP	Run ID: WC_190517D	Analysis Date: 5/17/2019 11:40:00 AM	Prep Date: 5/16/2019							
Analyte	Result	RL	SPK value	Ref Val	%REC	LowLimit	HighLimit	%RPD	RPDLimit	Qual
Total Dissolved Solids (Residue, Filtera		940	50.0	0	910.0			3.24	5	

Qualifiers:	<p>B Analyte detected in the associated Method Blank</p> <p>J Analyte detected between MDL and RL</p> <p>ND Not Detected at the Method Detection Limit</p> <p>RL Reporting Limit</p> <p>J Analyte detected between SDL and RL</p>	<p>DF Dilution Factor</p> <p>MDL Method Detection Limit</p> <p>R RPD outside accepted control limits</p> <p>S Spike Recovery outside control limits</p> <p>N Parameter not NELAP certified</p>
--------------------	---	--

ANALYTICAL REPORT

May 29, 2019



DHL Analytical, Inc.

Sample Delivery Group: L1100947
Samples Received: 05/21/2019
Project Number: 1905167
Description:

Report To: John DuPont
2300 Double Creek Drive
Round Rock, TX 78664

Entire Report Reviewed By:

Donna Eidson
Project Manager

Results relate only to the items tested or calibrated and are reported as rounded values. This test report shall not be reproduced, except in full, without written approval of the laboratory. Where applicable, sampling conducted by Pace National is performed per guidance provided in laboratory standard operating procedures: 060302, 060303, and 060304.

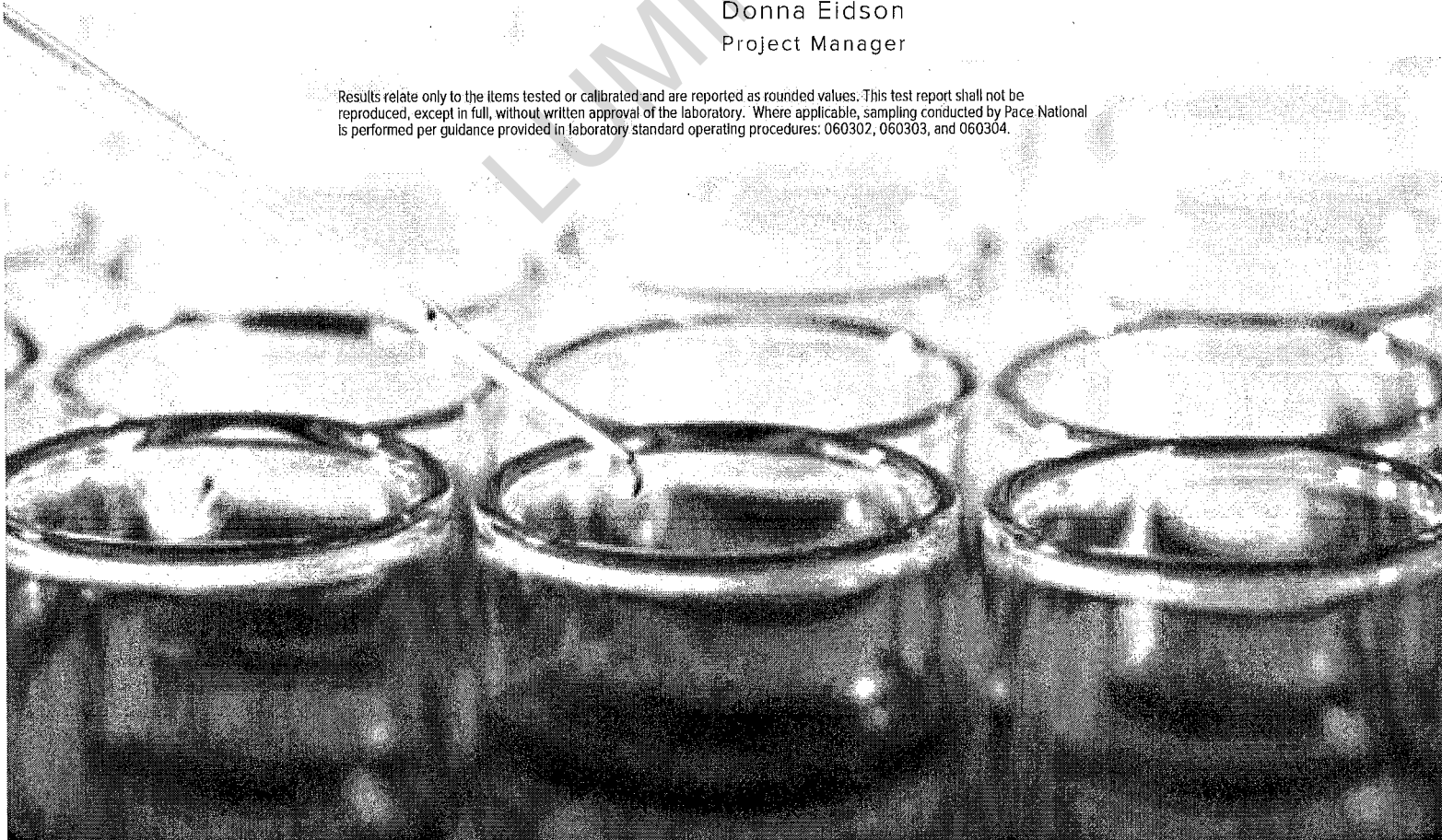

TABLE OF CONTENTS



Cp: Cover Page	1	
Tc: Table of Contents	2	
Ss: Sample Summary	3	
Cn: Case Narrative	4	
Sr: Sample Results	5	
LAKE SAMPLE L1100947-01	5	
LAKE SAMPLE L1100947-02	6	
Qc: Quality Control Summary	7	
Radiochemistry by Method 904	7	
Radiochemistry by Method SM7500Ra B M	8	
Gl: Glossary of Terms	9	
Al: Accreditations & Locations	10	
Sc: Sample Chain of Custody	11	

LUMINANT

SAMPLE SUMMARY

ONE LAB. NATIONWIDE.

LAKE SAMPLE L1100947-01 Non-Potable Water

	Collected by	Collected date/time	Received date/time
		05/14/19 10:05	05/21/19 10:10

Method	Batch	Dilution	Preparation date/time	Analysis date/time	Analyst	Location
Radiochemistry by Method 904	WG1284744	1	05/22/19 08:25	05/28/19 10:55	JMR	Mt. Juliet, TN
Radiochemistry by Method Calculation	WG1284773	1	05/23/19 15:02	05/28/19 10:55	RRE	Mt. Juliet, TN
Radiochemistry by Method SM7500Ra B M	WG1284773	1	05/23/19 15:02	05/24/19 17:05	RRE	Mt. Juliet, TN

1
Cp

2
Tc

3
Ss

4
Cn

5
Sr

6
Qc

7
Gl

8
Al

9
Sc

LAKE SAMPLE L1100947-02 Non-Potable Water

	Collected by	Collected date/time	Received date/time
		05/14/19 10:20	05/21/19 10:10

Method	Batch	Dilution	Preparation date/time	Analysis date/time	Analyst	Location
Radiochemistry by Method 904	WG1284744	1	05/22/19 08:25	05/28/19 10:55	JMR	Mt. Juliet, TN
Radiochemistry by Method Calculation	WG1284773	1	05/23/19 15:02	05/28/19 10:55	RRE	Mt. Juliet, TN
Radiochemistry by Method SM7500Ra B M	WG1284773	1	05/23/19 15:02	05/24/19 17:05	RRE	Mt. Juliet, TN

LUMINANT



All sample aliquots were received at the correct temperature, in the proper containers, with the appropriate preservatives, and within method specified holding times, unless qualified or notated within the report. Where applicable, all MDL (LOD) and RDL (LOQ) values reported for environmental samples have been corrected for the dilution factor used in the analysis. All radiochemical sample results for solids are reported on a dry weight basis with the exception of tritium, carbon-14 and radon, unless wet weight was requested by the client. All Method and Batch Quality Control are within established criteria except where addressed in this case narrative, a non-conformance form or properly qualified within the sample results. By my digital signature below, I affirm to the best of my knowledge, all problems/anomalies observed by the laboratory as having the potential to affect the quality of the data have been identified by the laboratory, and no information or data have been knowingly withheld that would affect the quality of the data.

Donna Eidson
Project Manager

¹ Cp

² Tc

³ Ss

⁴ Cn

⁵ Sr

⁶ Qc

⁷ Gl

⁸ Al

⁹ Sc

LUMINANT

LAKE SAMPLE

Collected date/time: 05/14/19 10:05

SAMPLE RESULTS - 01

L1100947

ONE LAB. NATIONWIDE.



Radiochemistry by Method 904

Analyte	Result	Qualifier	Uncertainty	MDA	Analysis Date	Batch
	pCi/l		+ / -	pCi/l	date / time	
RADIUM-228	0.369		0.449	0.769	05/28/2019 10:55	WG1284744
(T) Barium	102			62.0-143	05/28/2019 10:55	WG1284744
(T) Yttrium	118			79.0-136	05/28/2019 10:55	WG1284744

1 Cp

2 Tc

3 Ss

Radiochemistry by Method Calculation

Analyte	Result	Qualifier	Uncertainty	MDA	Analysis Date	Batch
	pCi/l		+ / -	pCi/l	date / time	
Combined Radium	0.772		0.734	1.08	05/28/2019 10:55	WG1284773

4 Cn

5 Sr

Radiochemistry by Method SM7500Ra B M

Analyte	Result	Qualifier	Uncertainty	MDA	Analysis Date	Batch
	pCi/l		+ / -	pCi/l	date / time	
RADIUM-226	0.403		0.285	0.311	05/24/2019 17:05	WG1284773
(T) Barium-133	92.1			30.0-143	05/24/2019 17:05	WG1284773

6 Qc

7 Gl

8 Al

9 Sc

LUMINANT

LAKE SAMPLE

SAMPLE RESULTS - 02

ONE LAB. NATIONWIDE.



Collected date/time: 05/14/19 10:20

L1100947

Radiochemistry by Method 904

Analyte	Result pCi/l	Qualifier	Uncertainty + / -	MDA pCi/l	Analysis Date date / time	Batch
RADIUM-228	-0.0402		0.349	0.599	05/28/2019 10:55	WG1284744
(T) Barium	113			62.0-143	05/28/2019 10:55	WG1284744
(T) Yttrium	114			79.0-136	05/28/2019 10:55	WG1284744

1 Cp

2 Tc

3 Ss

Radiochemistry by Method Calculation

Analyte	Result pCi/l	Qualifier	Uncertainty + / -	MDA pCi/l	Analysis Date date / time	Batch
Combined Radium	0.853		0.752	0.895	05/28/2019 10:55	WG1284773

4 Cn

5 Sr

Radiochemistry by Method SM7500Ra B M

Analyte	Result pCi/l	Qualifier	Uncertainty + / -	MDA pCi/l	Analysis Date date / time	Batch
RADIUM-226	0.853		0.403	0.296	05/24/2019 17:05	WG1284773
(T) Barium-133	83.8			30.0-143	05/24/2019 17:05	WG1284773

6 Qc

7 Gl

8 Al

9 Sc

LUMINANT

Method Blank (MB)

(MB) R3415641-1 05/28/19 10:55

Analyte	MB Result pCi/l	MB Qualifier	MB MDA pCi/l
Radium-228	-0.164		0.413
(T) Barium	108		
(T) Yttrium	115		

L1100192-01 Original Sample (OS) • Duplicate (DUP)

(OS) L1100192-01 05/28/19 10:55 • (DUP) R3415641-5 05/28/19 10:55

Analyte	Original Result pCi/l	DUP Result pCi/l	Dilution	DUP RPD %	DUP RER	DUP Qualifier	DUP RPD Limits %	DUP RER Limit
Radium-228	0.157	-0.0367	1	200	0.366		20	3
(T) Barium	91.7	102						
(T) Yttrium	110	107						

Laboratory Control Sample (LCS)

(LCS) R3415641-2 05/28/19 10:55

Analyte	Spike Amount pCi/l	LCS Result pCi/l	LCS Rec. %	Rec. Limits %	LCS Qualifier
Radium-228	5.00	4.47	89.4	80.0-120	
(T) Barium			103		
(T) Yttrium			107		

L1100922-01 Original Sample (OS) • Matrix Spike (MS) • Matrix Spike Duplicate (MSD)

(OS) L1100922-01 05/28/19 10:55 • (MS) R3415641-3 05/28/19 10:55 • (MSD) R3415641-4 05/28/19 10:55

Analyte	Spike Amount pCi/l	Original Result pCi/l	MS Result pCi/l	MSD Result pCi/l	MS Rec. %	MSD Rec. %	Dilution	Rec. Limits %	MS Qualifier	MSD Qualifier	RPD %	MS RER	RPD Limits %
Radium-228	7.14	-0.136	7.62	7.50	107	105	1	70.0-130			1.50		20
(T) Barium		111			107	110							
(T) Yttrium		114			107	110							

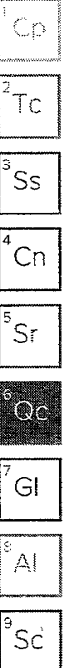

Method Blank (MB)

(MB) R3415635-1 05/24/19 17:04

Analyte	MB Result pCi/l	MB Qualifier	MB MDA pCi/l
Radium-226	0.459		0.209
(T) Barium-133	84.6		

L1100844-01 Original Sample (OS) • Duplicate (DUP)

(OS) L1100844-01 05/24/19 17:04 • (DUP) R3415635-5 05/24/19 17:04

Analyte	Original Result pCi/l	DUP Result pCi/l	Dilution	DUP RPD %	DUP RER	DUP Qualifier	DUP RPD Limits	DUP RER Limit
Radium-226	0.495	0.573	1	14.6	0.182		20	3
(T) Barium-133	90.4	88.8						

Laboratory Control Sample (LCS)

(LCS) R3415635-2 05/24/19 17:04

Analyte	Spike Amount pCi/l	LCS Result pCi/l	LCS Rec. %	Rec. Limits %	LCS Qualifier
Radium-226	20.1	19.1	95.0	80.0-120	
(T) Barium-133			79.1		

L1100433-01 Original Sample (OS) • Matrix Spike (MS) • Matrix Spike Duplicate (MSD)

(OS) L1100433-01 05/24/19 17:04 • (MS) R3415635-3 05/24/19 17:04 • (MSD) R3415635-4 05/24/19 17:04

Analyte	Spike Amount pCi/l	Original Result pCi/l	MS Result pCi/l	MSD Result pCi/l	MS Rec. %	MSD Rec. %	Dilution	Rec. Limits %	MS Qualifier	MSD Qualifier	RPD %	MS RER	RPD Limits %
Radium-226	20.1	1.16	19.9	20.9	93.2	98.0	1	75.0-125			4.71		20
(T) Barium-133		83.2			81.1	84.7							

- 1 Cp
- 2 Tc
- 3 Ss
- 4 Cn
- 5 Sr
- 6 Qc
- 7 Gf
- 8 Al
- 9 Sc



Guide to Reading and Understanding Your Laboratory Report

The information below is designed to better explain the various terms used in your report of analytical results from the Laboratory. This is not intended as a comprehensive explanation, and if you have additional questions please contact your project representative.

Abbreviations and Definitions

MDA	Minimum Detectable Activity.
Rec.	Recovery.
RER	Replicate Error Ratio.
RPD	Relative Percent Difference.
SDG	Sample Delivery Group.
(T)	Tracer - A radioisotope of known concentration added to a solution of chemically equivalent radioisotopes at a known concentration to assist in monitoring the yield of the chemical separation.
Analyte	The name of the particular compound or analysis performed. Some Analyses and Methods will have multiple analytes reported.
Dilution	If the sample matrix contains an interfering material, the sample preparation volume or weight values differ from the standard, or if concentrations of analytes in the sample are higher than the highest limit of concentration that the laboratory can accurately report, the sample may be diluted for analysis. If a value different than 1 is used in this field, the result reported has already been corrected for this factor.
Limits	These are the target % recovery ranges or % difference value that the laboratory has historically determined as normal for the method and analyte being reported. Successful QC Sample analysis will target all analytes recovered or duplicated within these ranges.
Original Sample	The non-spiked sample in the prep batch used to determine the Relative Percent Difference (RPD) from a quality control sample. The Original Sample may not be included within the reported SDG.
Qualifier	This column provides a letter and/or number designation that corresponds to additional information concerning the result reported. If a Qualifier is present, a definition per Qualifier is provided within the Glossary and Definitions page and potentially a discussion of possible implications of the Qualifier in the Case Narrative if applicable.
Result	The actual analytical final result (corrected for any sample specific characteristics) reported for your sample. If there was no measurable result returned for a specific analyte, the result in this column may state "ND" (Not Detected) or "BDL" (Below Detectable Levels). The information in the results column should always be accompanied by either an MDL (Method Detection Limit) or RDL (Reporting Detection Limit) that defines the lowest value that the laboratory could detect or report for this analyte.
Uncertainty (Radiochemistry)	Confidence level of 2 sigma.
Case Narrative (Cn)	A brief discussion about the included sample results, including a discussion of any non-conformances to protocol observed either at sample receipt by the laboratory from the field or during the analytical process. If present, there will be a section in the Case Narrative to discuss the meaning of any data qualifiers used in the report.
Quality Control Summary (Qc)	This section of the report includes the results of the laboratory quality control analyses required by procedure or analytical methods to assist in evaluating the validity of the results reported for your samples. These analyses are not being performed on your samples typically, but on laboratory generated material.
Sample Chain of Custody (Sc)	This is the document created in the field when your samples were initially collected. This is used to verify the time and date of collection, the person collecting the samples, and the analyses that the laboratory is requested to perform. This chain of custody also documents all persons (excluding commercial shippers) that have had control or possession of the samples from the time of collection until delivery to the laboratory for analysis.
Sample Results (Sr)	This section of your report will provide the results of all testing performed on your samples. These results are provided by sample ID and are separated by the analyses performed on each sample. The header line of each analysis section for each sample will provide the name and method number for the analysis reported.
Sample Summary (Ss)	This section of the Analytical Report defines the specific analyses performed for each sample ID, including the dates and times of preparation and/or analysis.

Qualifier Description

The remainder of this page intentionally left blank, there are no qualifiers applied to this SDG.

1 Cp

2 Tc

3 Ss

4 Cn

5 Sr

6 Qc

7 Gl

8 Al

9 Sc

ACCREDITATIONS & LOCATIONS

ONE LAB. NATIONWIDE.



Pace National is the only environmental laboratory accredited/certified to support your work nationwide from one location. One phone call, one point of contact, one laboratory. No other lab is as accessible or prepared to handle your needs throughout the country. Our capacity and capability from our single location laboratory is comparable to the collective totals of the network laboratories in our industry. The most significant benefit to our one location design is the design of our laboratory campus. The model is conducive to accelerated productivity, decreasing turn-around time, and preventing cross contamination, thus protecting sample integrity. Our focus on premium quality and prompt service allows us to be YOUR LAB OF CHOICE.

* Not all certifications held by the laboratory are applicable to the results reported in the attached report.
 * Accreditation is only applicable to the test methods specified on each scope of accreditation held by Pace National.

¹ Cp

² Tc

³ Ss

⁴ Cn

⁵ Sr

⁶ Qc

⁷ Gl

AI

⁹ Sc

State Accreditations

Alabama	40660	Nebraska	NE-05-15-05
Alaska	17-026	Nevada	TN-03-2002-34
Arizona	AZ0612	New Hampshire	2975
Arkansas	88-0469	New Jersey-NELAP	TN002
California	2932	New Mexico ¹	n/a
Colorado	TN00003	New York	11742
Connecticut	PH-0197	North Carolina	Env375
Florida	EB7487	North Carolina ¹	DW21704
Georgia	NELAP	North Carolina ³	41
Georgia ¹	923	North Dakota	R-140
Idaho	TN00003	Ohio-VAP	CL0069
Illinois	200008	Oklahoma	9915
Indiana	C-TN-01	Oregon	TN200002
Iowa	364	Pennsylvania	68-02979
Kansas	E-10277	Rhode Island	LA000356
Kentucky ^{1,6}	90010	South Carolina	84004
Kentucky ²	16	South Dakota	n/a
Louisiana	AI30792	Tennessee ^{1,4}	2006
Louisiana ¹	LA180010	Texas	T104704245-18-15
Maine	TN0002	Texas ⁵	LAB0152
Maryland	324	Utah	TN00003
Massachusetts	M-TN003	Vermont	VT2006
Michigan	9958	Virginia	460132
Minnesota	047-999-395	Washington	C847
Mississippi	TN00003	West Virginia	233
Missouri	340	Wisconsin	9980939910
Montana	CERT0086	Wyoming	A2LA

Third Party Federal Accreditations

AZLA - ISO 17025	1461.01	AIHA-LAP, LLC EMLAP	100789
AZLA - ISO 17025 ⁵	1461.02	DOD	1461.01
Canada	1461.01	USDA	P330-15-00234
EPA-Crypto	TN00003		

¹ Drinking Water ² Underground Storage Tanks ³ Aquatic Toxicity ⁴ Chemical/Microbiological ⁵ Mold ⁶ Wastewater n/a Accreditation not applicable

Our Locations

Pace National has sixty-four client support centers that provide sample pickup and/or the delivery of sampling supplies. If you would like assistance from one of our support offices, please contact our main office. Pace National performs all testing at our central laboratory.

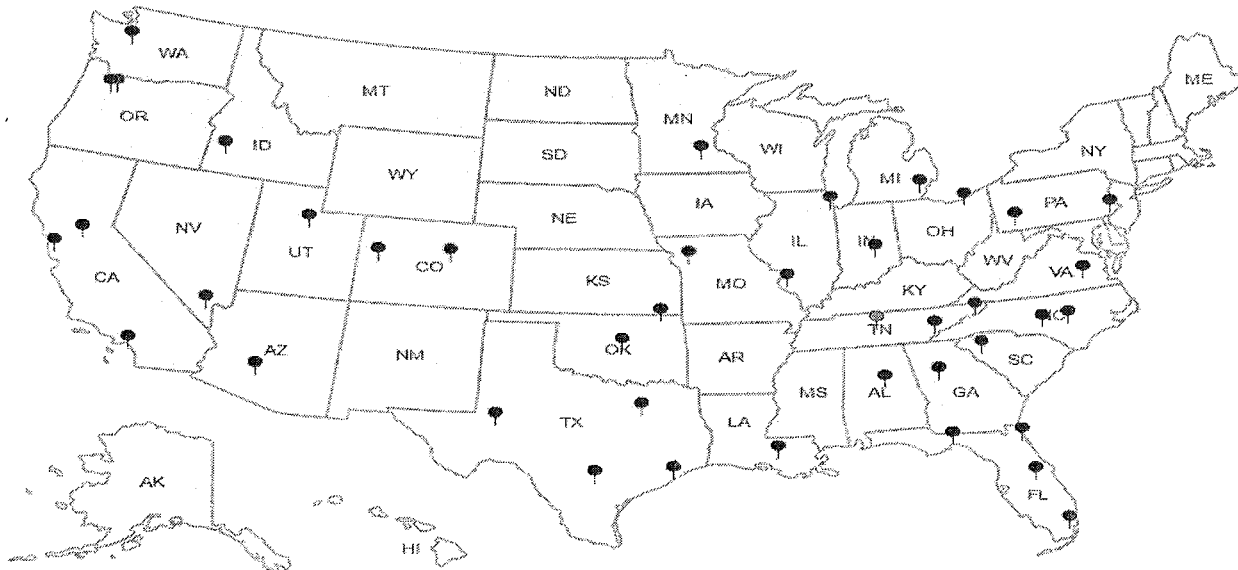

**Pace Analytical National Center for Testing & Innovation
Cooler Receipt Form**

Client: <i>DHL RTX</i>	SDG#: <i>1100947</i>		
Cooler Received/Opened On: <i>5/21/19</i>	Temperature: <i>Amb</i>		
Received By: Brock Fariss			
Signature: <i>[Signature]</i>			
Receipt Check List	NP	Yes	No
COC Seal Present / Intact?	/		
COC Signed / Accurate?		/	
Bottles arrive intact?		/	
Correct bottles used?		/	
Sufficient volume sent?		/	
If Applicable			
VOA Zero headspace?		/	
Preservation Correct / Checked?			

1100947

CHAIN-OF-CUSTODY RECORD

DHL Analytical, Inc.
 2300 Double Creek Drive
 Round Rock, TX 78664
 TEL: (512) 388-8222
 Work Order: 1905167

FAX: (512) 388-8229

H004

Subcontractor:
 Pace Analytical
 12065 Lebanon Rd
 Mt. Juliet, TN 37122

TEL: (615) 773-5923
 FAX:
 Acct #: DHLRRTX

15-May-19

Sample Id	Matrix	DHL#	Date Collected	Bottle Type	Requested Tests						
					RA-228 E904.0	RA-226 M7500 Ra B M					
Lake Sample	Aqueous	-01D	05/14/19 10:05 AM	1LHDPEHNO3		1					-01
Lake Sample	Aqueous	-01E	05/14/19 10:05 AM	1LHDPEHNO3	1						01
Pond Sample	Aqueous	-02D	05/14/19 10:20 AM	1LHDPEHNO3		1					02
Pond Sample	Aqueous	-02E	05/14/19 10:20 AM	1LHDPEHNO3	1						02

LUMINANT

General Comments:

Please analyze these samples with Normal Turnaround Time.
 Report RA-226, Ra-228 & Combined per Specs.
 Quality Control Package Needed: Standard - NELAC Rad Test compliant
 Email to cac@dhlanalytical.com & dupont@dhlanalytical.com

Relinquished by:
 Relinquished by:

Date/Time
 5/17/19 1200

Received by: *[Signature]*
 Received by:

Date/Time
 5/21/19 1010

51
 VPS
 Rec: 4

Amro

5 mR/hr

Quantitative X-Ray Diffraction by Rietveld Refinement

Report Prepared for: Golder Associates - Will Vienne

Project Number/ LIMS No. 17431-01 / MI7012-JUN19

Batch: Martin Lake Ash Ponds

Sample Receipt: June 13, 2019

Sample Analysis: June 28, 2019

Reporting Date: July 19, 2019

Instrument: Panalytical X'pert Pro Diffractometer

Test Conditions: Co radiation, 40 kV, 45 mA
Regular Scanning: Step: 0.033°, Step time:0.15s, 2θ range: 6-70°

Interpretations: HighScore Plus software using Crystallography Open Database (COD) and Joint Committee on Powder Diffraction Standards -International Center for Diffraction Data (JCPDS-ICDD).

Detection Limit: 0.5-2%. Strongly dependent on crystallinity.

Contents:

- 1) Method Summary
- 2) Summary of Mineral Assemblages
- 3) Quantitative XRD Results
- 4) XRD Pattern(s)



Ben Eaton
Junior Mineralogist



Lain Glossop H.B.Sc
Senior Mineralogist



Method Summary

Mineral Identification and Interpretation:

Mineral identification and interpretation involve matching the diffraction pattern of a test sample material to patterns of single-phase reference materials. The reference patterns from the Crystallography Open Database (COD) and the Joint Committee on Powder Diffraction Standards - International Center for Diffraction Data (JCPDS-ICDD).

Interpretations do not reflect the presence of non-crystalline and/or amorphous compounds, except when internal standards have been added by request. Mineral proportions may be strongly influenced by crystallinity, crystal structure and preferred orientations. Mineral or compound identification and quantitative analysis results should be accompanied by supporting chemical assay data or other additional tests.

Quantitative Rietveld Analysis:

Panalytical HighScore Plus software was used to perform the quantitative Rietveld Analysis. This software uses a graphics based profile analysis program built around a non-linear least squares fitting system, to quantitatively determine the amount of different phases present in a multicomponent sample. Whole pattern analyses are predicated by the fact that the X-ray diffraction pattern is a total sum of both instrumental and specimen factors. Unlike other peak intensity-based methods, the Rietveld method uses a least squares approach to refine a theoretical line profile (shown as a blue pattern in the analyses plots) until it matches the obtained experimental patterns (shown as the coloured pattern in the analyses plots).

Rietveld refinement is completed with a set of minerals specifically identified for the sample. Zero values indicate that the mineral was included in the refinement calculations, but the calculated concentration was less than 0.5 wt%. Minerals not identified by the analyst are not included in refinement calculations for specific samples and are indicated with a dash.

DISCLAIMER: This document is issued by the Company under its General Conditions of Service accessible at <http://www.sgs.com/en/Terms-and-Conditions.aspx>. Attention is drawn to the limitation of liability, indemnification and jurisdiction issues defined therein. Any holder of this document is advised that information contained hereon reflects the Company's findings at the time of its intervention only and within the limits of Client's instructions, if any. The Company's sole responsibility is to its Client and this document does not exonerate parties to a transaction from exercising all their rights and obligations under the transaction documents. Any unauthorized alteration, forgery or falsification of the content or appearance of this document is unlawful and offenders may be prosecuted to the fullest extent of the law.

WARNING: The sample(s) to which the findings recorded herein (the "Findings") relate was(were) drawn and / or provided by the Client or by a third party acting at the Client's direction. The Findings constitute no warranty of the sample's representativeness of any goods and strictly relate to the sample(s). The Company accepts no liability with regard to the origin or source from which the sample(s) is/are said to be extracted.

Summary of Rietveld Quantitative Analysis X-ray Diffraction Results

Quantitative X-ray Diffraction Results

Mineral/Compound	1	2	3
	AP-2019-1 (30-31")	AP-2019-2 (35-36")	AP-2019-3 (18-19")
	(wt %)	(wt %)	(wt %)
Quartz	60.8	66.0	99.2
Albite	22.3	16.2	0.8
K-Feldspar	1.3	1.4	--
Chlorite	1.3	2.7	--
Muscovite	1.4	3.2	--
*Vermiculite	0.9	0.7	--
*Kaolinite	3.0	3.4	--
Illite	8.3	6.1	--
*Montmorillonite	0.7	0.4	--
TOTAL	100	100	100

Zero values indicate that the mineral was included in the refinement, but the calculated concentration is below a measurable value.

Dashes indicate that the mineral was not identified by the analyst and not included in the refinement calculation for the sample.

* Tentative identification of clays only, further clay XRD analysis will be required for positive identification

Mineral/Compound	Formula
Quartz	SiO_2
Albite	$\text{NaAlSi}_3\text{O}_8$
K-Feldspar	KAlSi_3O_8
Chlorite	$(\text{Mg}_3, \text{Fe}_2)\text{Al}(\text{AlSi}_3)\text{O}_{10}(\text{OH})_8$
Muscovite	$\text{KAl}_2(\text{AlSi}_3\text{O}_{10})(\text{OH})_2$
Vermiculite	$(\text{Mg}, \text{Fe}, \text{Al})_2(\text{Al}, \text{Si})_4\text{O}_{10}(\text{OH})_2 \cdot 4(\text{H}_2\text{O})$
Kaolinite	$\text{Al}_2\text{Si}_2\text{O}_5(\text{OH})_4$
Illite	$(\text{K}, \text{H}_3\text{O})(\text{Al}, \text{Mg}, \text{Fe})_2(\text{Si}, \text{Al})_4\text{O}_{10}[(\text{OH})_2, (\text{H}_2\text{O})]$
Montmorillonite	$\text{Na}_{0.2}\text{Ca}_{0.1}\text{Al}_{1.5}\text{Mg}_{0.5}\text{Si}_4\text{O}_{10}(\text{OH})_2 \cdot 4(\text{H}_2\text{O})$

Counts

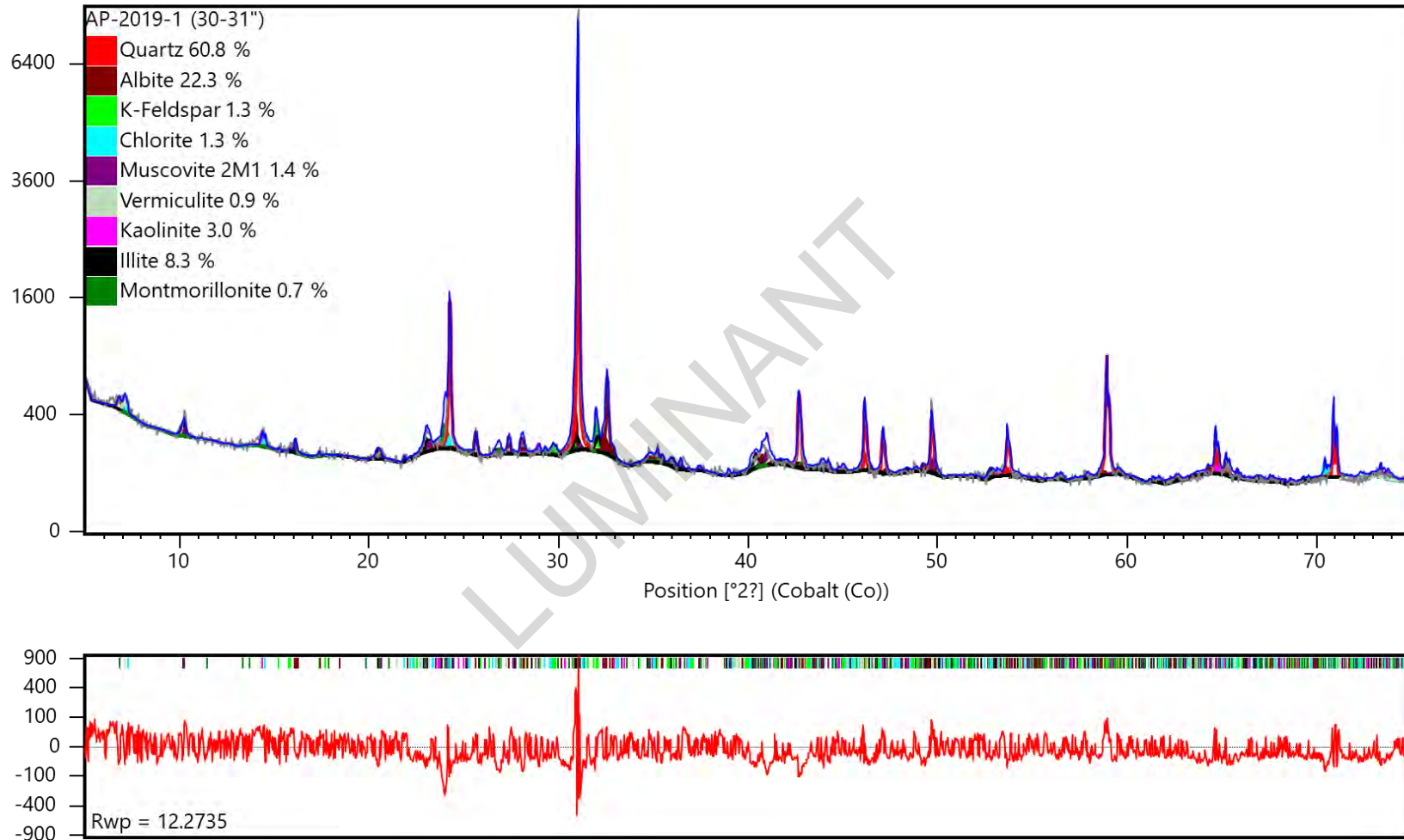

X-ray diffractogram. The upper pattern is the measured diffractogram, the blue curve is the calculated pattern from the Rietveld Refinement and the lower red curve is the difference plot.

Counts

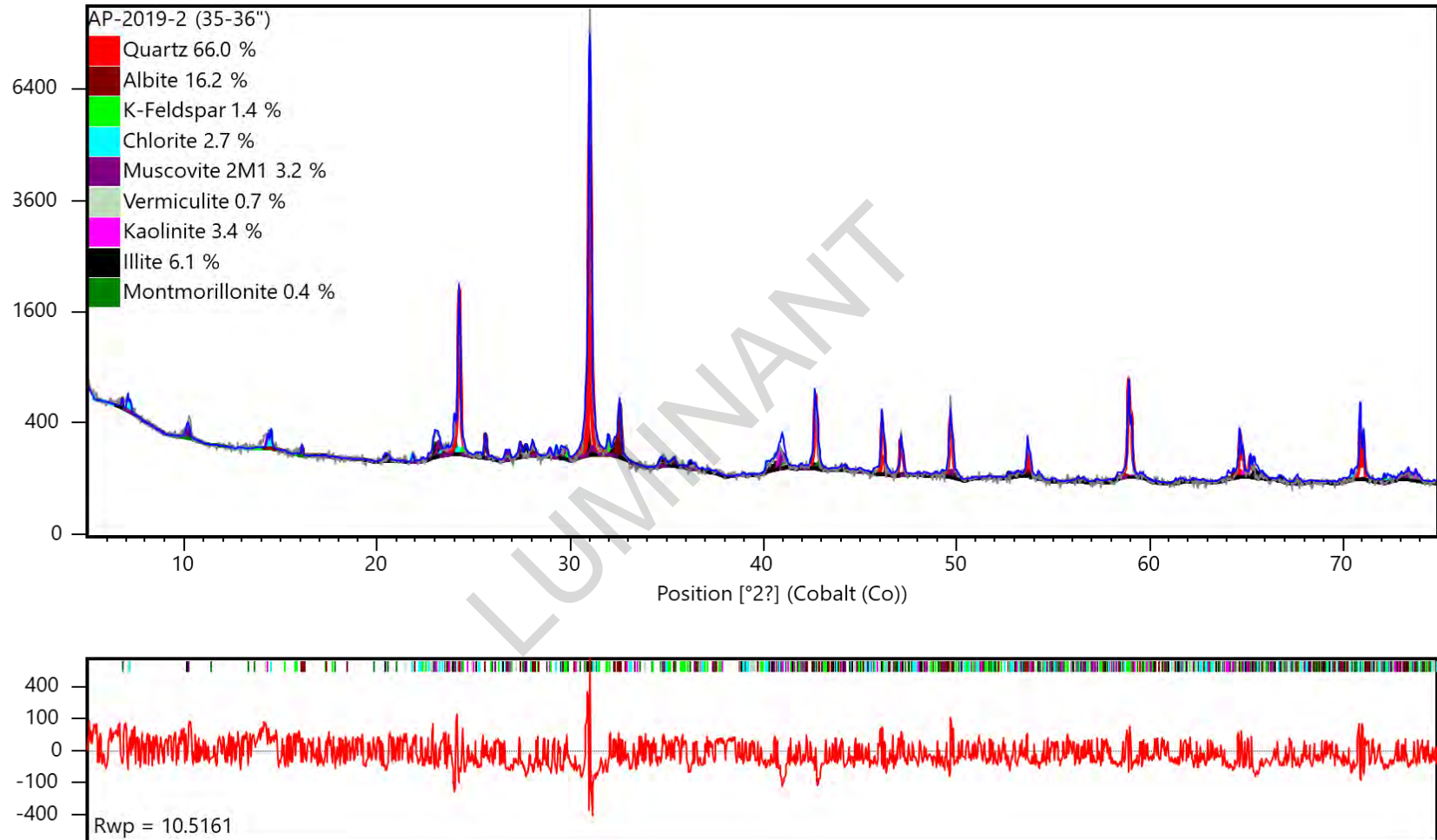

X-ray diffractogram. The upper pattern is the measured diffractogram, the blue curve is the calculated pattern from the Rietveld Refinement and the lower red curve is the difference plot.

Counts

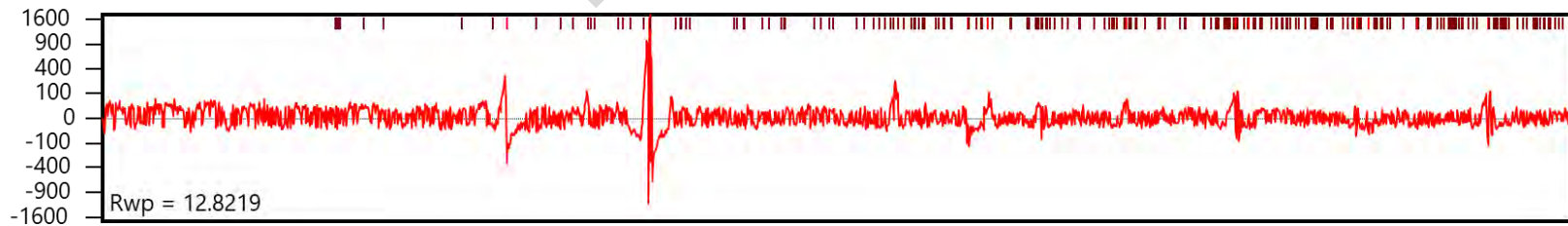
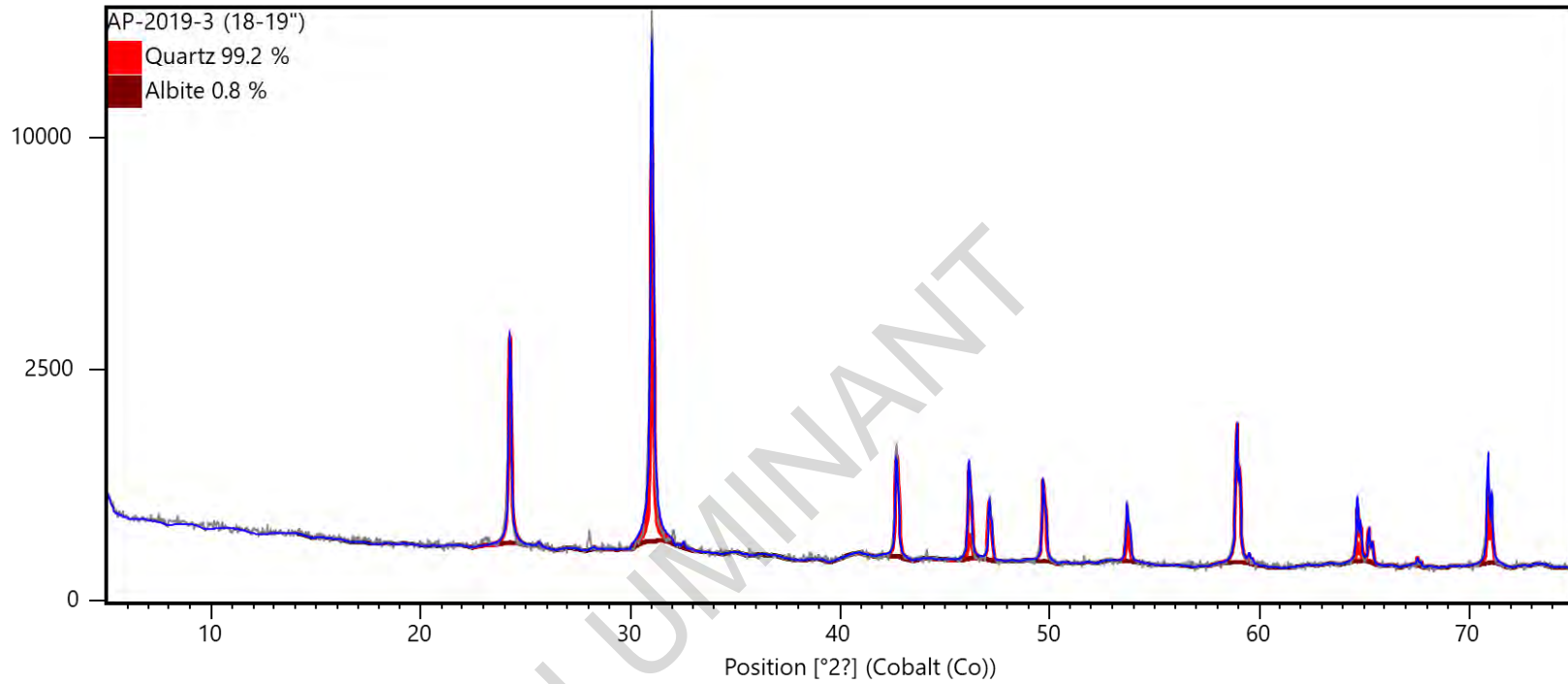

X-ray diffractogram. The upper pattern is the measured diffractogram, the blue curve is the calculated pattern from the Rietveld Refinement and the lower red curve is the difference plot.

ANALYTICAL REPORT

Eurofins TestAmerica, Knoxville
5815 Middlebrook Pike
Knoxville, TN 37921
Tel: (865)291-3000

Laboratory Job ID: 140-15490-1

Client Project/Site: Martin Lake Ash Ponds - SEP + Totals

For:

Golder Associates Inc.
2201 Double Creek Dr
Suite 4004
Round Rock, Texas 78664

Attn: Will Vienne

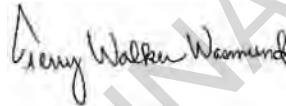

Authorized for release by:
7/18/2019 5:51:37 PM

Terry Walker Wasmund, Project Manager II
(865)291-3000

terry.wasmund@testamericainc.com

LINKS

Review your project
results through
TotalAccess

Have a Question?



Visit us at:
www.testamericainc.com

This report has been electronically signed and authorized by the signatory. Electronic signature is intended to be the legally binding equivalent of a traditionally handwritten signature.

Results relate only to the items tested and the sample(s) as received by the laboratory.



Table of Contents

Cover Page	1
Table of Contents	2
Definitions/Glossary	3
Case Narrative	4
Detection Summary	6
Client Sample Results	11
Default Detection Limits	20
QC Sample Results	24
QC Association Summary	37
Lab Chronicle	43
Method Summary	55
Sample Summary	56
Chain of Custody	57

LUMINANT

Definitions/Glossary

Client: Golder Associates Inc.
Project/Site: Martin Lake Ash Ponds - SEP + Totals

Job ID: 140-15490-1

Qualifiers

Metals

Qualifier	Qualifier Description
*	LCS or LCSD is outside acceptance limits.
*	RPD of the LCS and LCSD exceeds the control limits
B	Compound was found in the blank and sample.
F1	MS and/or MSD Recovery is outside acceptance limits.
F5	Duplicate RPD exceeds limit, and one or both sample results are less than 5 times RL. The data are considered valid because the absolute difference is less than the RL.
J	Result is less than the RL but greater than or equal to the MDL and the concentration is an approximate value.

Glossary

Abbreviation	These commonly used abbreviations may or may not be present in this report.
α	Listed under the "D" column to designate that the result is reported on a dry weight basis
%R	Percent Recovery
CFL	Contains Free Liquid
CNF	Contains No Free Liquid
DER	Duplicate Error Ratio (normalized absolute difference)
Dil Fac	Dilution Factor
DL	Detection Limit (DoD/DOE)
DL, RA, RE, IN	Indicates a Dilution, Re-analysis, Re-extraction, or additional Initial metals/anion analysis of the sample
DLC	Decision Level Concentration (Radiochemistry)
EDL	Estimated Detection Limit (Dioxin)
LOD	Limit of Detection (DoD/DOE)
LOQ	Limit of Quantitation (DoD/DOE)
MDA	Minimum Detectable Activity (Radiochemistry)
MDC	Minimum Detectable Concentration (Radiochemistry)
MDL	Method Detection Limit
ML	Minimum Level (Dioxin)
NC	Not Calculated
ND	Not Detected at the reporting limit (or MDL or EDL if shown)
PQL	Practical Quantitation Limit
QC	Quality Control
RER	Relative Error Ratio (Radiochemistry)
RL	Reporting Limit or Requested Limit (Radiochemistry)
RPD	Relative Percent Difference, a measure of the relative difference between two points
TEF	Toxicity Equivalent Factor (Dioxin)
TEQ	Toxicity Equivalent Quotient (Dioxin)

Case Narrative

Client: Golder Associates Inc.
Project/Site: Martin Lake Ash Ponds - SEP + Totals

Job ID: 140-15490-1

Job ID: 140-15490-1

Laboratory: Eurofins TestAmerica, Knoxville

Narrative

Job Narrative 140-15490-1

Receipt

The samples were received on 6/5/2019 at 9:20 AM. The samples arrived in good condition, properly preserved, and on ice. The temperature of the cooler at receipt was 1.2° C.

Metals

7 Step Sequential Extraction Procedure

These soil samples were prepared and analyzed using Eurofins TestAmerica Knoxville standard operating procedure KNOX-MT-0008, "7 Step Sequential Extraction Procedure". SW-846 Method 6010B as incorporated in Eurofins TestAmerica Knoxville standard operating procedure KNOX-MT-0007 was used to perform the final instrument analyses.

An aliquot of each sample was sequentially extracted using the steps listed below:

- **Step 1 - Exchangeable Fraction:** A 5 gram aliquot of sample was extracted with 25 mL of 1M magnesium sulfate (MgSO₄), centrifuged and filtered. 5 mL of the resulting leachate was digested using method 3010A and analyzed by method 6010B. Results are reported in mg/kg on a dry weight basis.
- **Step 2 - Carbonate Fraction:** The sample residue from step 1 was extracted with 25 mL of 1M sodium acetate/acetic acid (NaOAc/HOAc) at pH 5, centrifuged and filtered. 5 mL of the resulting leachate was digested using method 3010A and analyzed by method 6010B. Results are reported in mg/kg on a dry weight basis.
- **Step 3 - Non-crystalline Materials Fraction:** The sample residue from step 2 was extracted with 25 mL of 0.2M ammonium oxalate (pH 3), centrifuged and filtered. 5 mL of the resulting leachate was digested using method 3010A and analyzed by method 6010B. Results are reported in mg/kg on a dry weight basis.
- **Step 4 - Metal Hydroxide Fraction:** The sample residue from step 3 was extracted with 25 mL of 1M hydroxylamine hydrochloride solution in 25% v/v acetic acid, centrifuged and filtered. 5 mL of the resulting leachate was digested using method 3010A and analyzed by method 6010B. Results are reported in mg/kg on a dry weight basis.
- **Step 5 - Organic-bound Fraction:** The sample residue from step 4 was extracted three times with 25 mL of 5% sodium hypochlorite (NaClO) at pH 9.5, centrifuged and filtered. The resulting leachates were combined and 5 mL were digested using method 3010A and analyzed by method 6010B. Results are reported in mg/kg on a dry weight basis.
- **Step 6 - Acid/Sulfide Fraction:** The sample residue from step 5 was extracted with 25 mL of a 3:1:2 v/v solution of HCl-HNO₃-H₂O, centrifuged and filtered. 5 mL of the resulting leachate was diluted to 50 mL with reagent water and analyzed by method 6010B. Results are reported in mg/kg on a dry weight basis.
- **Step 7 - Residual Fraction:** A 1.0 g aliquot of the sample residue from step 6 was digested using HF, HNO₃, HCl and H₃BO₃. The digestate was analyzed by ICP using method 6010B. Results are reported in mg/kg on a dry weight basis.

In addition, a 1.0 g aliquot of the original sample was digested using HF, HNO₃, HCl and H₃BO₃. The digestate was analyzed by ICP using method 6010B. Total metal results are reported in mg/kg on a dry weight basis.

Results were calculated using the following equation:

$$\text{Result, } \mu\text{g/g or mg/Kg, dry weight} = (C \times V \times V1 \times D) / (W \times S \times V2)$$

Where:

- C = Concentration from instrument readout, $\mu\text{g/mL}$
- V = Final volume of digestate, mL
- D = Instrument dilution factor
- V1 = Total volume of leachate, mL
- V2 = Volume of leachate digested, mL
- W = Wet weight of sample, g
- S = Percent solids/100

A method blank, laboratory control sample and laboratory control sample duplicate were prepared and analyzed with each SEP step in order to provide information about both the presence of elements of interest in the extraction solutions, and the recovery of elements of

Case Narrative

Client: Golder Associates Inc.
Project/Site: Martin Lake Ash Ponds - SEP + Totals

Job ID: 140-15490-1

Job ID: 140-15490-1 (Continued)

Laboratory: Eurofins TestAmerica, Knoxville (Continued)

interest from the extraction solutions. Results outside of laboratory QC limits do not reflect out of control performance, but rather the effect of the extraction solution upon the analyte.

A laboratory sample duplicate was prepared and analyzed with each batch of samples in order to provide information regarding the reproducibility of the procedure.

SEP Report Notes

The final report lists the results for each step, the result for the total digestion of the sample, and a sum of the results of steps 1 through 7 by element.

Magnesium was not reported for step 1 because the extraction solution for this step (magnesium sulfate) contains high levels of magnesium. Sodium was not reported for steps 2 and 5 since the extraction solutions for these steps contain high levels of sodium. The sum of steps 1 through 7 is much higher than the total result for sodium and magnesium due to the magnesium and sodium introduced by the extraction solutions.

The step 1 digestates were reanalyzed for vanadium at a 1/10 dilution due to positive interelement interferences resulting from the high magnesium results. The reporting limits were adjusted accordingly.

The digestates for steps 1, 2 and 5 were analyzed at a dilution due to instrument problems caused by the high solids content of the digestates. The reporting limits were adjusted accordingly.

The serial dilution performed for samples (140-15490-A-1-A SD ^5) and (140-15490-A-1-AD SD ^50) associated with batch 140-31713 was outside control limits.

Samples AP-2019-1 (30-31) (140-15490-1), AP-2019-2 (35-36) (140-15490-2), AP-2019-3 (18-19) (140-15490-3), (140-15490-A-1-AE DU) and (140-15490-A-1-B DU) were diluted due to the presence of Silicon or Titanium which interferes with Arsenic, Cobalt, Selenium and Thallium. Elevated reporting limits (RLs) are provided.

Samples AP-2019-1 (30-31) (140-15490-1), AP-2019-2 (35-36) (140-15490-2), AP-2019-3 (18-19) (140-15490-3), (140-15490-A-1-AE DU) and (140-15490-A-1-B DU) were diluted for Aluminum and Barium due to the nature of the sample matrix. Elevated reporting limits (RLs) are provided.

No additional analytical or quality issues were noted, other than those described above or in the Definitions/Glossary page.

General Chemistry - % Moisture

The samples were analyzed for percent moisture using SOP number KNOX-WC-0012 (based on Modified MCAWW 160.3 and SM2540B and on the percent moisture determinations described in methods 3540C and 3550B).

No additional analytical or quality issues were noted, other than those described above or in the Definitions/Glossary page.

Comments

No additional comments.

Detection Summary

Client: Golder Associates Inc.
 Project/Site: Martin Lake Ash Ponds - SEP + Totals

Job ID: 140-15490-1

Client Sample ID: AP-2019-1 (30-31)

Lab Sample ID: 140-15490-1

Analyte	Result	Qualifier	RL	MDL	Unit	Dil Fac	D	Method	Prep Type
Barium	0.88	J	13	0.63	mg/Kg	4	☼	6010B SEP	Step 1
Cobalt	0.54	J	13	0.24	mg/Kg	4	☼	6010B SEP	Step 1
Manganese	3.1	J	3.9	0.16	mg/Kg	4	☼	6010B SEP	Step 1
Aluminum	9.7	J*	39	6.3	mg/Kg	3	☼	6010B SEP	Step 2
Barium	0.76	J*	9.9	0.47	mg/Kg	3	☼	6010B SEP	Step 2
Selenium	0.76	J B	2.0	0.67	mg/Kg	3	☼	6010B SEP	Step 2
Aluminum	88		13	2.8	mg/Kg	1	☼	6010B SEP	Step 3
Arsenic	1.8		0.66	0.17	mg/Kg	1	☼	6010B SEP	Step 3
Barium	4.3	B	3.3	0.16	mg/Kg	1	☼	6010B SEP	Step 3
Beryllium	0.067	J	0.33	0.020	mg/Kg	1	☼	6010B SEP	Step 3
Cobalt	0.34	J	3.3	0.059	mg/Kg	1	☼	6010B SEP	Step 3
Iron	580		6.6	3.8	mg/Kg	1	☼	6010B SEP	Step 3
Manganese	2.4	B	0.99	0.036	mg/Kg	1	☼	6010B SEP	Step 3
Selenium	0.22	J B	0.66	0.22	mg/Kg	1	☼	6010B SEP	Step 3
Aluminum	1700		13	2.1	mg/Kg	1	☼	6010B SEP	Step 4
Arsenic	2.8	B	0.66	0.29	mg/Kg	1	☼	6010B SEP	Step 4
Barium	16		3.3	0.16	mg/Kg	1	☼	6010B SEP	Step 4
Beryllium	0.13	J	0.33	0.021	mg/Kg	1	☼	6010B SEP	Step 4
Cobalt	1.5	J	3.3	0.070	mg/Kg	1	☼	6010B SEP	Step 4
Iron	3900		6.6	3.8	mg/Kg	1	☼	6010B SEP	Step 4
Li	3.0	J	3.3	0.20	mg/Kg	1	☼	6010B SEP	Step 4
Manganese	18		0.99	0.17	mg/Kg	1	☼	6010B SEP	Step 4
Aluminum	62	J*	200	31	mg/Kg	5	☼	6010B SEP	Step 5
Barium	7.0	J*	49	2.4	mg/Kg	5	☼	6010B SEP	Step 5
Aluminum	2300		13	2.1	mg/Kg	1	☼	6010B SEP	Step 6
Arsenic	0.94		0.66	0.20	mg/Kg	1	☼	6010B SEP	Step 6
Barium	18		3.3	0.16	mg/Kg	1	☼	6010B SEP	Step 6
Beryllium	0.067	J	0.33	0.016	mg/Kg	1	☼	6010B SEP	Step 6
Cobalt	0.90	J	3.3	0.061	mg/Kg	1	☼	6010B SEP	Step 6
Iron	2500		6.6	3.8	mg/Kg	1	☼	6010B SEP	Step 6
Li	2.1	J	3.3	0.20	mg/Kg	1	☼	6010B SEP	Step 6
Manganese	16		0.99	0.33	mg/Kg	1	☼	6010B SEP	Step 6
Aluminum	29000		130	21	mg/Kg	10	☼	6010B SEP	Step 7
Arsenic	1.2		0.66	0.17	mg/Kg	1	☼	6010B SEP	Step 7
Barium	390		33	1.6	mg/Kg	10	☼	6010B SEP	Step 7
Beryllium	0.56		0.33	0.0099	mg/Kg	1	☼	6010B SEP	Step 7
Cobalt	0.79	J	6.6	0.39	mg/Kg	2	☼	6010B SEP	Step 7
Iron	5200		6.6	5.4	mg/Kg	1	☼	6010B SEP	Step 7
Li	9.6		3.3	0.20	mg/Kg	1	☼	6010B SEP	Step 7
Manganese	26		0.99	0.068	mg/Kg	1	☼	6010B SEP	Step 7
Mo	0.19	J	2.6	0.11	mg/Kg	1	☼	6010B SEP	Step 7
Thallium	0.48	J	4.6	0.47	mg/Kg	2	☼	6010B SEP	Step 7
Aluminum	33000		10	1.6	mg/Kg	1		6010B SEP	Sum of Steps 1-7
Arsenic	6.9		0.50	0.13	mg/Kg	1		6010B SEP	Sum of Steps 1-7
Barium	440		2.5	0.12	mg/Kg	1		6010B SEP	Sum of Steps 1-7
Beryllium	0.83		0.25	0.0075	mg/Kg	1		6010B SEP	Sum of Steps 1-7
Cobalt	4.0		2.5	0.023	mg/Kg	1		6010B SEP	Sum of Steps 1-7

This Detection Summary does not include radiochemical test results.

Eurofins TestAmerica, Knoxville

Detection Summary

Client: Golder Associates Inc.
Project/Site: Martin Lake Ash Ponds - SEP + Totals

Job ID: 140-15490-1

Client Sample ID: AP-2019-1 (30-31) (Continued)

Lab Sample ID: 140-15490-1

Analyte	Result	Qualifier	RL	MDL	Unit	Dil Fac	D	Method	Prep Type
Iron	12000		5.0	4.1	mg/Kg	1		6010B SEP	Sum of Steps 1-7
Li	15		2.5	0.15	mg/Kg	1		6010B SEP	Sum of Steps 1-7
Manganese	66		0.75	0.052	mg/Kg	1		6010B SEP	Sum of Steps 1-7
Mo	0.19	J	2.0	0.082	mg/Kg	1		6010B SEP	Sum of Steps 1-7
Selenium	0.98		0.50	0.17	mg/Kg	1		6010B SEP	Sum of Steps 1-7
Thallium	0.48	J	1.8	0.18	mg/Kg	1		6010B SEP	Sum of Steps 1-7
Chromium	13	F1	1.8	0.27	mg/Kg	1	✳	6010B	Total/NA
Lead	6.4		1.8	0.34	mg/Kg	1	✳	6010B	Total/NA
Aluminum	60000		130	21	mg/Kg	10	✳	6010B	Total/NA
Arsenic	6.8		0.66	0.17	mg/Kg	1	✳	6010B	Total/NA
Barium	680		33	1.6	mg/Kg	10	✳	6010B	Total/NA
Beryllium	0.89		0.33	0.0099	mg/Kg	1	✳	6010B	Total/NA
Cobalt	3.8	J	6.6	0.39	mg/Kg	2	✳	6010B	Total/NA
Iron	11000		6.6	5.4	mg/Kg	1	✳	6010B	Total/NA
Lithium	18		3.3	0.20	mg/Kg	1	✳	6010B	Total/NA
Manganese	66		0.99	0.068	mg/Kg	1	✳	6010B	Total/NA
Molybdenum	0.40	J	2.6	0.11	mg/Kg	1	✳	6010B	Total/NA
Hg	0.081	J	0.13	0.053	mg/Kg	1	✳	7470A	Total/NA

Client Sample ID: AP-2019-2 (35-36)

Lab Sample ID: 140-15490-2

Analyte	Result	Qualifier	RL	MDL	Unit	Dil Fac	D	Method	Prep Type
Aluminum	19	J	51	8.2	mg/Kg	4	✳	6010B SEP	Step 1
Barium	0.88	J	13	0.61	mg/Kg	4	✳	6010B SEP	Step 1
Cobalt	1.6	J	13	0.23	mg/Kg	4	✳	6010B SEP	Step 1
Iron	23	J	25	15	mg/Kg	4	✳	6010B SEP	Step 1
Manganese	33		3.8	0.16	mg/Kg	4	✳	6010B SEP	Step 1
Aluminum	18	J *	38	6.1	mg/Kg	3	✳	6010B SEP	Step 2
Barium	0.67	J *	9.6	0.46	mg/Kg	3	✳	6010B SEP	Step 2
Cobalt	0.27	J	9.6	0.24	mg/Kg	3	✳	6010B SEP	Step 2
Iron	110	*	19	11	mg/Kg	3	✳	6010B SEP	Step 2
Manganese	4.2		2.9	1.1	mg/Kg	3	✳	6010B SEP	Step 2
Selenium	0.90	J B	1.9	0.65	mg/Kg	3	✳	6010B SEP	Step 2
Aluminum	97		13	2.7	mg/Kg	1	✳	6010B SEP	Step 3
Arsenic	0.97		0.64	0.17	mg/Kg	1	✳	6010B SEP	Step 3
Barium	4.1	B	3.2	0.15	mg/Kg	1	✳	6010B SEP	Step 3
Beryllium	0.028	J	0.32	0.019	mg/Kg	1	✳	6010B SEP	Step 3
Cobalt	0.17	J	3.2	0.057	mg/Kg	1	✳	6010B SEP	Step 3
Iron	1100		6.4	3.7	mg/Kg	1	✳	6010B SEP	Step 3
Manganese	1.5	B	0.96	0.034	mg/Kg	1	✳	6010B SEP	Step 3
Aluminum	1800		13	2.0	mg/Kg	1	✳	6010B SEP	Step 4
Arsenic	0.78	B	0.64	0.28	mg/Kg	1	✳	6010B SEP	Step 4
Barium	23		3.2	0.15	mg/Kg	1	✳	6010B SEP	Step 4
Beryllium	0.078	J	0.32	0.020	mg/Kg	1	✳	6010B SEP	Step 4
Cobalt	1.5	J	3.2	0.068	mg/Kg	1	✳	6010B SEP	Step 4
Iron	3800		6.4	3.7	mg/Kg	1	✳	6010B SEP	Step 4
Li	4.2		3.2	0.19	mg/Kg	1	✳	6010B SEP	Step 4

This Detection Summary does not include radiochemical test results.

Eurofins TestAmerica, Knoxville

Detection Summary

Client: Golder Associates Inc.
 Project/Site: Martin Lake Ash Ponds - SEP + Totals

Job ID: 140-15490-1

Client Sample ID: AP-2019-2 (35-36) (Continued)

Lab Sample ID: 140-15490-2

Analyte	Result	Qualifier	RL	MDL	Unit	Dil Fac	D	Method	Prep Type
Manganese	31		0.96	0.17	mg/Kg	1	✳	6010B SEP	Step 4
Aluminum	55	J *	190	30	mg/Kg	5	✳	6010B SEP	Step 5
Barium	11	J *	48	2.3	mg/Kg	5	✳	6010B SEP	Step 5
Cobalt	0.85	J *	48	0.76	mg/Kg	5	✳	6010B SEP	Step 5
Manganese	3.9	J *	14	2.4	mg/Kg	5	✳	6010B SEP	Step 5
Aluminum	2000		13	2.0	mg/Kg	1	✳	6010B SEP	Step 6
Arsenic	0.74		0.64	0.19	mg/Kg	1	✳	6010B SEP	Step 6
Barium	16		3.2	0.15	mg/Kg	1	✳	6010B SEP	Step 6
Beryllium	0.061	J	0.32	0.015	mg/Kg	1	✳	6010B SEP	Step 6
Cobalt	0.80	J	3.2	0.059	mg/Kg	1	✳	6010B SEP	Step 6
Iron	3300		6.4	3.7	mg/Kg	1	✳	6010B SEP	Step 6
Li	2.1	J	3.2	0.19	mg/Kg	1	✳	6010B SEP	Step 6
Manganese	19		0.96	0.32	mg/Kg	1	✳	6010B SEP	Step 6
Aluminum	26000		130	20	mg/Kg	10	✳	6010B SEP	Step 7
Arsenic	0.71		0.64	0.17	mg/Kg	1	✳	6010B SEP	Step 7
Barium	330		32	1.5	mg/Kg	10	✳	6010B SEP	Step 7
Beryllium	0.51		0.32	0.0096	mg/Kg	1	✳	6010B SEP	Step 7
Cobalt	1.1	J	6.4	0.38	mg/Kg	2	✳	6010B SEP	Step 7
Iron	5600		6.4	5.2	mg/Kg	1	✳	6010B SEP	Step 7
Li	11		3.2	0.19	mg/Kg	1	✳	6010B SEP	Step 7
Manganese	34		0.96	0.066	mg/Kg	1	✳	6010B SEP	Step 7
Mo	0.17	J	2.5	0.10	mg/Kg	1	✳	6010B SEP	Step 7
Thallium	0.70	J	4.5	0.46	mg/Kg	2	✳	6010B SEP	Step 7
Aluminum	30000		10	1.6	mg/Kg	1		6010B SEP	Sum of Steps 1-7
Arsenic	3.2		0.50	0.13	mg/Kg	1		6010B SEP	Sum of Steps 1-7
Barium	390		2.5	0.12	mg/Kg	1		6010B SEP	Sum of Steps 1-7
Beryllium	0.68		0.25	0.0075	mg/Kg	1		6010B SEP	Sum of Steps 1-7
Cobalt	6.3		2.5	0.023	mg/Kg	1		6010B SEP	Sum of Steps 1-7
Iron	14000		5.0	4.1	mg/Kg	1		6010B SEP	Sum of Steps 1-7
Li	18		2.5	0.15	mg/Kg	1		6010B SEP	Sum of Steps 1-7
Manganese	130		0.75	0.052	mg/Kg	1		6010B SEP	Sum of Steps 1-7
Mo	0.17	J	2.0	0.082	mg/Kg	1		6010B SEP	Sum of Steps 1-7
Selenium	0.90		0.50	0.17	mg/Kg	1		6010B SEP	Sum of Steps 1-7
Thallium	0.70	J	1.8	0.18	mg/Kg	1		6010B SEP	Sum of Steps 1-7
Chromium	12		1.8	0.27	mg/Kg	1	✳	6010B	Total/NA
Lead	6.2		1.8	0.34	mg/Kg	1	✳	6010B	Total/NA
Aluminum	62000		130	20	mg/Kg	10	✳	6010B	Total/NA
Arsenic	3.0		0.64	0.17	mg/Kg	1	✳	6010B	Total/NA
Barium	560		32	1.5	mg/Kg	10	✳	6010B	Total/NA
Beryllium	0.72		0.32	0.0096	mg/Kg	1	✳	6010B	Total/NA
Cobalt	6.2	J	16	0.96	mg/Kg	5	✳	6010B	Total/NA
Iron	13000		6.4	5.2	mg/Kg	1	✳	6010B	Total/NA
Lithium	26		3.2	0.19	mg/Kg	1	✳	6010B	Total/NA

This Detection Summary does not include radiochemical test results.

Eurofins TestAmerica, Knoxville

Detection Summary

Client: Golder Associates Inc.
 Project/Site: Martin Lake Ash Ponds - SEP + Totals

Job ID: 140-15490-1

Client Sample ID: AP-2019-2 (35-36) (Continued)

Lab Sample ID: 140-15490-2

Analyte	Result	Qualifier	RL	MDL	Unit	Dil Fac	D	Method	Prep Type
Manganese	150		0.96	0.066	mg/Kg	1	☼	6010B	Total/NA
Molybdenum	0.41	J	2.5	0.10	mg/Kg	1	☼	6010B	Total/NA
Hg	0.12	J	0.13	0.051	mg/Kg	1	☼	7470A	Total/NA

Client Sample ID: AP-2019-3 (18-19)

Lab Sample ID: 140-15490-3

Analyte	Result	Qualifier	RL	MDL	Unit	Dil Fac	D	Method	Prep Type
Aluminum	14	J	50	8.0	mg/Kg	4	☼	6010B SEP	Step 1
Cobalt	0.87	J	13	0.23	mg/Kg	4	☼	6010B SEP	Step 1
Iron	15	J	25	15	mg/Kg	4	☼	6010B SEP	Step 1
Manganese	1.2	J	3.8	0.16	mg/Kg	4	☼	6010B SEP	Step 1
Selenium	0.68	J B	1.9	0.64	mg/Kg	3	☼	6010B SEP	Step 2
Aluminum	30		13	2.6	mg/Kg	1	☼	6010B SEP	Step 3
Barium	2.3	J B	3.1	0.15	mg/Kg	1	☼	6010B SEP	Step 3
Beryllium	0.025	J	0.31	0.019	mg/Kg	1	☼	6010B SEP	Step 3
Iron	57		6.3	3.6	mg/Kg	1	☼	6010B SEP	Step 3
Manganese	0.11	J B	0.94	0.034	mg/Kg	1	☼	6010B SEP	Step 3
Selenium	0.23	J B	0.63	0.21	mg/Kg	1	☼	6010B SEP	Step 3
Aluminum	880		13	2.0	mg/Kg	1	☼	6010B SEP	Step 4
Arsenic	0.63	B	0.63	0.28	mg/Kg	1	☼	6010B SEP	Step 4
Barium	6.9		3.1	0.15	mg/Kg	1	☼	6010B SEP	Step 4
Beryllium	0.069	J	0.31	0.020	mg/Kg	1	☼	6010B SEP	Step 4
Cobalt	0.53	J	3.1	0.066	mg/Kg	1	☼	6010B SEP	Step 4
Iron	2300		6.3	3.6	mg/Kg	1	☼	6010B SEP	Step 4
Li	0.53	J	3.1	0.19	mg/Kg	1	☼	6010B SEP	Step 4
Manganese	4.2		0.94	0.16	mg/Kg	1	☼	6010B SEP	Step 4
Selenium	0.65	B *	0.63	0.59	mg/Kg	1	☼	6010B SEP	Step 4
Aluminum	120	J *	190	29	mg/Kg	5	☼	6010B SEP	Step 5
Aluminum	1200		13	2.0	mg/Kg	1	☼	6010B SEP	Step 6
Arsenic	0.24	J	0.63	0.19	mg/Kg	1	☼	6010B SEP	Step 6
Barium	2.1	J	3.1	0.15	mg/Kg	1	☼	6010B SEP	Step 6
Beryllium	0.026	J	0.31	0.015	mg/Kg	1	☼	6010B SEP	Step 6
Cobalt	0.28	J	3.1	0.058	mg/Kg	1	☼	6010B SEP	Step 6
Iron	820		6.3	3.6	mg/Kg	1	☼	6010B SEP	Step 6
Li	0.62	J	3.1	0.19	mg/Kg	1	☼	6010B SEP	Step 6
Manganese	2.9		0.94	0.31	mg/Kg	1	☼	6010B SEP	Step 6
Aluminum	12000		130	20	mg/Kg	10	☼	6010B SEP	Step 7
Arsenic	0.79	J	1.3	0.33	mg/Kg	2	☼	6010B SEP	Step 7
Barium	180		31	1.5	mg/Kg	10	☼	6010B SEP	Step 7
Beryllium	0.11	J	0.31	0.0094	mg/Kg	1	☼	6010B SEP	Step 7
Iron	2000		6.3	5.1	mg/Kg	1	☼	6010B SEP	Step 7
Li	6.0		3.1	0.19	mg/Kg	1	☼	6010B SEP	Step 7
Manganese	26		0.94	0.065	mg/Kg	1	☼	6010B SEP	Step 7
Mo	0.12	J	2.5	0.10	mg/Kg	1	☼	6010B SEP	Step 7
Aluminum	14000		10	1.6	mg/Kg	1		6010B SEP	Sum of Steps 1-7
Arsenic	1.7		0.50	0.13	mg/Kg	1		6010B SEP	Sum of Steps 1-7
Barium	190		2.5	0.12	mg/Kg	1		6010B SEP	Sum of Steps 1-7
Beryllium	0.23	J	0.25	0.0075	mg/Kg	1		6010B SEP	Sum of Steps 1-7

This Detection Summary does not include radiochemical test results.

Eurofins TestAmerica, Knoxville

Detection Summary

Client: Golder Associates Inc.
 Project/Site: Martin Lake Ash Ponds - SEP + Totals

Job ID: 140-15490-1

Client Sample ID: AP-2019-3 (18-19) (Continued)

Lab Sample ID: 140-15490-3

Analyte	Result	Qualifier	RL	MDL	Unit	Dil Fac	D	Method	Prep Type
Cobalt	1.7	J	2.5	0.023	mg/Kg	1		6010B SEP	Sum of Steps 1-7
Iron	5200		5.0	4.1	mg/Kg	1		6010B SEP	Sum of Steps 1-7
Li	7.2		2.5	0.15	mg/Kg	1		6010B SEP	Sum of Steps 1-7
Manganese	35		0.75	0.052	mg/Kg	1		6010B SEP	Sum of Steps 1-7
Mo	0.12	J	2.0	0.082	mg/Kg	1		6010B SEP	Sum of Steps 1-7
Selenium	1.6		0.50	0.17	mg/Kg	1		6010B SEP	Sum of Steps 1-7
Chromium	4.4		1.8	0.26	mg/Kg	1	✳	6010B	Total/NA
Lead	3.9		1.8	0.33	mg/Kg	1	✳	6010B	Total/NA
Aluminum	20000		130	20	mg/Kg	10	✳	6010B	Total/NA
Arsenic	2.9	J	3.1	0.81	mg/Kg	5	✳	6010B	Total/NA
Barium	240		31	1.5	mg/Kg	10	✳	6010B	Total/NA
Beryllium	0.42		0.31	0.0094	mg/Kg	1	✳	6010B	Total/NA
Cobalt	3.3	J	16	0.94	mg/Kg	5	✳	6010B	Total/NA
Iron	8000		6.3	5.1	mg/Kg	1	✳	6010B	Total/NA
Lithium	9.6		3.1	0.19	mg/Kg	1	✳	6010B	Total/NA
Manganese	47		0.94	0.065	mg/Kg	1	✳	6010B	Total/NA
Molybdenum	0.28	J	2.5	0.10	mg/Kg	1	✳	6010B	Total/NA

LUMINA

This Detection Summary does not include radiochemical test results.

Eurofins TestAmerica, Knoxville

- 1
- 2
- 3
- 4
- 5
- 6
- 7
- 8
- 9
- 10
- 11
- 12
- 13

Client Sample Results

Client: Golder Associates Inc.
Project/Site: Martin Lake Ash Ponds - SEP + Totals

Job ID: 140-15490-1

Client Sample ID: AP-2019-1 (30-31)

Lab Sample ID: 140-15490-1

Date Collected: 06/03/19 11:36

Matrix: Solid

Date Received: 06/05/19 09:20

Percent Solids: 76.0

Method: 6010B SEP - SEP Metals (ICP) - Step 1

Analyte	Result	Qualifier	RL	MDL	Unit	D	Prepared	Analyzed	Dil Fac
Aluminum	ND		53	8.4	mg/Kg	☼	06/29/19 08:00	07/11/19 12:49	4
Antimony	ND		16	1.5	mg/Kg	☼	06/29/19 08:00	07/11/19 12:49	4
Arsenic	ND		2.6	0.68	mg/Kg	☼	06/29/19 08:00	07/11/19 12:49	4
Barium	0.88	J	13	0.63	mg/Kg	☼	06/29/19 08:00	07/11/19 12:49	4
Beryllium	ND		1.3	0.41	mg/Kg	☼	06/29/19 08:00	07/11/19 12:49	4
Cobalt	0.54	J	13	0.24	mg/Kg	☼	06/29/19 08:00	07/11/19 12:49	4
Iron	ND		26	15	mg/Kg	☼	06/29/19 08:00	07/11/19 12:49	4
Li	ND		13	0.79	mg/Kg	☼	06/29/19 08:00	07/11/19 12:49	4
Manganese	3.1	J	3.9	0.16	mg/Kg	☼	06/29/19 08:00	07/11/19 12:49	4
Mo	ND		11	0.43	mg/Kg	☼	06/29/19 08:00	07/11/19 12:49	4
Selenium	ND		2.6	0.89	mg/Kg	☼	06/29/19 08:00	07/11/19 12:49	4
Thallium	ND		9.2	1.1	mg/Kg	☼	06/29/19 08:00	07/11/19 12:49	4

Method: 6010B SEP - SEP Metals (ICP) - Step 2

Analyte	Result	Qualifier	RL	MDL	Unit	D	Prepared	Analyzed	Dil Fac
Aluminum	9.7	J *	39	6.3	mg/Kg	☼	06/30/19 08:00	07/11/19 14:21	3
Antimony	ND		12	1.1	mg/Kg	☼	06/30/19 08:00	07/11/19 14:21	3
Arsenic	ND		2.0	0.51	mg/Kg	☼	06/30/19 08:00	07/11/19 14:21	3
Barium	0.76	J *	9.9	0.47	mg/Kg	☼	06/30/19 08:00	07/11/19 14:21	3
Beryllium	ND	*	0.99	0.063	mg/Kg	☼	06/30/19 08:00	07/11/19 14:21	3
Cobalt	ND		9.9	0.25	mg/Kg	☼	06/30/19 08:00	07/11/19 14:21	3
Iron	ND	*	20	11	mg/Kg	☼	06/30/19 08:00	07/11/19 14:21	3
Li	ND		9.9	0.59	mg/Kg	☼	06/30/19 08:00	07/11/19 14:21	3
Manganese	ND		3.0	1.1	mg/Kg	☼	06/30/19 08:00	07/11/19 14:21	3
Mo	ND		7.9	0.32	mg/Kg	☼	06/30/19 08:00	07/11/19 14:21	3
Selenium	0.76	J B	2.0	0.67	mg/Kg	☼	06/30/19 08:00	07/11/19 14:21	3
Thallium	ND		6.9	0.83	mg/Kg	☼	06/30/19 08:00	07/11/19 14:21	3

Method: 6010B SEP - SEP Metals (ICP) - Step 3

Analyte	Result	Qualifier	RL	MDL	Unit	D	Prepared	Analyzed	Dil Fac
Aluminum	88		13	2.8	mg/Kg	☼	07/02/19 08:00	07/11/19 16:06	1
Antimony	ND		3.9	0.37	mg/Kg	☼	07/02/19 08:00	07/11/19 16:06	1
Arsenic	1.8		0.66	0.17	mg/Kg	☼	07/02/19 08:00	07/11/19 16:06	1
Barium	4.3	B	3.3	0.16	mg/Kg	☼	07/02/19 08:00	07/11/19 16:06	1
Beryllium	0.067	J	0.33	0.020	mg/Kg	☼	07/02/19 08:00	07/11/19 16:06	1
Cobalt	0.34	J	3.3	0.059	mg/Kg	☼	07/02/19 08:00	07/11/19 16:06	1
Iron	580		6.6	3.8	mg/Kg	☼	07/02/19 08:00	07/11/19 16:06	1
Li	ND		3.3	0.20	mg/Kg	☼	07/02/19 08:00	07/11/19 16:06	1
Manganese	2.4	B	0.99	0.036	mg/Kg	☼	07/02/19 08:00	07/11/19 16:06	1
Mo	ND		2.6	0.11	mg/Kg	☼	07/02/19 08:00	07/11/19 16:06	1
Selenium	0.22	J B	0.66	0.22	mg/Kg	☼	07/02/19 08:00	07/11/19 16:06	1
Thallium	ND		2.3	0.28	mg/Kg	☼	07/02/19 08:00	07/11/19 16:06	1

Method: 6010B SEP - SEP Metals (ICP) - Step 4

Analyte	Result	Qualifier	RL	MDL	Unit	D	Prepared	Analyzed	Dil Fac
Aluminum	1700		13	2.1	mg/Kg	☼	07/03/19 08:00	07/11/19 17:49	1
Antimony	ND		3.9	0.59	mg/Kg	☼	07/03/19 08:00	07/11/19 17:49	1
Arsenic	2.8	B	0.66	0.29	mg/Kg	☼	07/03/19 08:00	07/11/19 17:49	1
Barium	16		3.3	0.16	mg/Kg	☼	07/03/19 08:00	07/11/19 17:49	1
Beryllium	0.13	J	0.33	0.021	mg/Kg	☼	07/03/19 08:00	07/11/19 17:49	1

Eurofins TestAmerica, Knoxville

Client Sample Results

Client: Golder Associates Inc.
Project/Site: Martin Lake Ash Ponds - SEP + Totals

Job ID: 140-15490-1

Client Sample ID: AP-2019-1 (30-31)

Lab Sample ID: 140-15490-1

Date Collected: 06/03/19 11:36

Matrix: Solid

Date Received: 06/05/19 09:20

Percent Solids: 76.0

Method: 6010B SEP - SEP Metals (ICP) - Step 4 (Continued)

Analyte	Result	Qualifier	RL	MDL	Unit	D	Prepared	Analyzed	Dil Fac
Cobalt	1.5	J	3.3	0.070	mg/Kg	☼	07/03/19 08:00	07/11/19 17:49	1
Iron	3900		6.6	3.8	mg/Kg	☼	07/03/19 08:00	07/11/19 17:49	1
Li	3.0	J	3.3	0.20	mg/Kg	☼	07/03/19 08:00	07/11/19 17:49	1
Manganese	18		0.99	0.17	mg/Kg	☼	07/03/19 08:00	07/11/19 17:49	1
Mo	ND		2.6	0.11	mg/Kg	☼	07/03/19 08:00	07/11/19 17:49	1
Selenium	ND	*	0.66	0.62	mg/Kg	☼	07/03/19 08:00	07/11/19 17:49	1
Thallium	ND		2.3	0.38	mg/Kg	☼	07/03/19 08:00	07/11/19 17:49	1

Method: 6010B SEP - SEP Metals (ICP) - Step 5

Analyte	Result	Qualifier	RL	MDL	Unit	D	Prepared	Analyzed	Dil Fac
Aluminum	62	J*	200	31	mg/Kg	☼	07/10/19 08:00	07/12/19 11:54	5
Antimony	ND		59	5.5	mg/Kg	☼	07/10/19 08:00	07/12/19 11:54	5
Arsenic	ND		9.9	2.5	mg/Kg	☼	07/10/19 08:00	07/12/19 11:54	5
Barium	7.0	J*	49	2.4	mg/Kg	☼	07/10/19 08:00	07/12/19 11:54	5
Beryllium	ND	*	4.9	0.41	mg/Kg	☼	07/10/19 08:00	07/12/19 11:54	5
Cobalt	ND	*	49	0.79	mg/Kg	☼	07/10/19 08:00	07/12/19 11:54	5
Iron	ND	*	99	58	mg/Kg	☼	07/10/19 08:00	07/12/19 11:54	5
Li	ND		49	2.9	mg/Kg	☼	07/10/19 08:00	07/12/19 11:54	5
Manganese	ND	*	15	2.4	mg/Kg	☼	07/10/19 08:00	07/12/19 11:54	5
Mo	ND		39	1.6	mg/Kg	☼	07/10/19 08:00	07/12/19 11:54	5
Selenium	ND		9.9	3.4	mg/Kg	☼	07/10/19 08:00	07/12/19 11:54	5
Thallium	ND	*	35	4.6	mg/Kg	☼	07/10/19 08:00	07/12/19 11:54	5

Method: 6010B SEP - SEP Metals (ICP) - Step 6

Analyte	Result	Qualifier	RL	MDL	Unit	D	Prepared	Analyzed	Dil Fac
Aluminum	2300		13	2.1	mg/Kg	☼	07/10/19 08:00	07/12/19 13:29	1
Antimony	ND		3.9	0.37	mg/Kg	☼	07/10/19 08:00	07/12/19 13:29	1
Arsenic	0.94		0.66	0.20	mg/Kg	☼	07/10/19 08:00	07/12/19 13:29	1
Barium	18		3.3	0.16	mg/Kg	☼	07/10/19 08:00	07/12/19 13:29	1
Beryllium	0.067	J	0.33	0.016	mg/Kg	☼	07/10/19 08:00	07/12/19 13:29	1
Cobalt	0.90	J	3.3	0.061	mg/Kg	☼	07/10/19 08:00	07/12/19 13:29	1
Iron	2500		6.6	3.8	mg/Kg	☼	07/10/19 08:00	07/12/19 13:29	1
Li	2.1	J	3.3	0.20	mg/Kg	☼	07/10/19 08:00	07/12/19 13:29	1
Manganese	16		0.99	0.33	mg/Kg	☼	07/10/19 08:00	07/12/19 13:29	1
Mo	ND		2.6	0.13	mg/Kg	☼	07/10/19 08:00	07/12/19 13:29	1
Selenium	ND		0.66	0.22	mg/Kg	☼	07/10/19 08:00	07/12/19 13:29	1
Thallium	ND		2.3	0.28	mg/Kg	☼	07/10/19 08:00	07/12/19 13:29	1

Method: 6010B SEP - SEP Metals (ICP) - Step 7

Analyte	Result	Qualifier	RL	MDL	Unit	D	Prepared	Analyzed	Dil Fac
Aluminum	29000		130	21	mg/Kg	☼	07/12/19 09:08	07/15/19 13:08	10
Antimony	ND		3.9	0.18	mg/Kg	☼	07/12/19 09:08	07/15/19 11:39	1
Arsenic	1.2		0.66	0.17	mg/Kg	☼	07/12/19 09:08	07/15/19 11:39	1
Barium	390		33	1.6	mg/Kg	☼	07/12/19 09:08	07/15/19 13:08	10
Beryllium	0.56		0.33	0.0099	mg/Kg	☼	07/12/19 09:08	07/15/19 11:39	1
Cobalt	0.79	J	6.6	0.39	mg/Kg	☼	07/12/19 09:08	07/15/19 17:11	2
Iron	5200		6.6	5.4	mg/Kg	☼	07/12/19 09:08	07/15/19 11:39	1
Li	9.6		3.3	0.20	mg/Kg	☼	07/12/19 09:08	07/15/19 11:39	1
Manganese	26		0.99	0.068	mg/Kg	☼	07/12/19 09:08	07/15/19 11:39	1
Mo	0.19	J	2.6	0.11	mg/Kg	☼	07/12/19 09:08	07/15/19 11:39	1

Eurofins TestAmerica, Knoxville

Client Sample Results

Client: Golder Associates Inc.
Project/Site: Martin Lake Ash Ponds - SEP + Totals

Job ID: 140-15490-1

Client Sample ID: AP-2019-1 (30-31)

Lab Sample ID: 140-15490-1

Date Collected: 06/03/19 11:36

Matrix: Solid

Date Received: 06/05/19 09:20

Percent Solids: 76.0

Method: 6010B SEP - SEP Metals (ICP) - Step 7 (Continued)

Analyte	Result	Qualifier	RL	MDL	Unit	D	Prepared	Analyzed	Dil Fac
Selenium	ND		0.66	0.22	mg/Kg	☼	07/12/19 09:08	07/15/19 11:39	1
Thallium	0.48	J	4.6	0.47	mg/Kg	☼	07/12/19 09:08	07/15/19 17:11	2

Method: 6010B SEP - SEP Metals (ICP) - Sum of Steps 1-7

Analyte	Result	Qualifier	RL	MDL	Unit	D	Prepared	Analyzed	Dil Fac
Aluminum	33000		10	1.6	mg/Kg			07/16/19 17:31	1
Antimony	ND		3.0	0.14	mg/Kg			07/16/19 17:31	1
Arsenic	6.9		0.50	0.13	mg/Kg			07/16/19 17:31	1
Barium	440		2.5	0.12	mg/Kg			07/16/19 17:31	1
Beryllium	0.83		0.25	0.0075	mg/Kg			07/16/19 17:31	1
Cobalt	4.0		2.5	0.023	mg/Kg			07/16/19 17:31	1
Iron	12000		5.0	4.1	mg/Kg			07/16/19 17:31	1
Li	15		2.5	0.15	mg/Kg			07/16/19 17:31	1
Manganese	66		0.75	0.052	mg/Kg			07/16/19 17:31	1
Mo	0.19	J	2.0	0.082	mg/Kg			07/16/19 17:31	1
Selenium	0.98		0.50	0.17	mg/Kg			07/16/19 17:31	1
Thallium	0.48	J	1.8	0.18	mg/Kg			07/16/19 17:31	1

Method: 6010B - Metals (ICP)

Analyte	Result	Qualifier	RL	MDL	Unit	D	Prepared	Analyzed	Dil Fac
Boron	ND		25	12	mg/Kg	☼	06/26/19 08:00	07/10/19 12:59	1
Chromium	13	F1	1.8	0.27	mg/Kg	☼	06/26/19 08:00	07/10/19 12:59	1
Lead	6.4		1.8	0.34	mg/Kg	☼	06/26/19 08:00	07/10/19 12:59	1

Method: 6010B - SEP Metals (ICP) - Total

Analyte	Result	Qualifier	RL	MDL	Unit	D	Prepared	Analyzed	Dil Fac
Aluminum	60000		130	21	mg/Kg	☼	06/11/19 08:00	07/15/19 15:45	10
Antimony	ND		3.9	0.18	mg/Kg	☼	06/11/19 08:00	07/15/19 14:24	1
Arsenic	6.8		0.66	0.17	mg/Kg	☼	06/11/19 08:00	07/15/19 14:24	1
Barium	680		33	1.6	mg/Kg	☼	06/11/19 08:00	07/15/19 15:45	10
Beryllium	0.89		0.33	0.0099	mg/Kg	☼	06/11/19 08:00	07/15/19 14:24	1
Cobalt	3.8	J	6.6	0.39	mg/Kg	☼	06/11/19 08:00	07/15/19 18:28	2
Iron	11000		6.6	5.4	mg/Kg	☼	06/11/19 08:00	07/15/19 14:24	1
Lithium	18		3.3	0.20	mg/Kg	☼	06/11/19 08:00	07/15/19 14:24	1
Manganese	66		0.99	0.068	mg/Kg	☼	06/11/19 08:00	07/15/19 14:24	1
Molybdenum	0.40	J	2.6	0.11	mg/Kg	☼	06/11/19 08:00	07/15/19 14:24	1
Selenium	ND		0.66	0.22	mg/Kg	☼	06/11/19 08:00	07/15/19 14:24	1
Thallium	ND		4.6	0.47	mg/Kg	☼	06/11/19 08:00	07/15/19 18:28	2

Method: 7470A - SEP Mercury (CVAA) - Total

Analyte	Result	Qualifier	RL	MDL	Unit	D	Prepared	Analyzed	Dil Fac
Hg	0.081	J	0.13	0.053	mg/Kg	☼	06/11/19 08:00	06/16/19 14:04	1

Client Sample Results

Client: Golder Associates Inc.
 Project/Site: Martin Lake Ash Ponds - SEP + Totals

Job ID: 140-15490-1

Client Sample ID: AP-2019-2 (35-36)

Lab Sample ID: 140-15490-2

Date Collected: 06/03/19 13:20

Matrix: Solid

Date Received: 06/05/19 09:20

Percent Solids: 78.5

Method: 6010B SEP - SEP Metals (ICP) - Step 1

Analyte	Result	Qualifier	RL	MDL	Unit	D	Prepared	Analyzed	Dil Fac
Aluminum	19	J	51	8.2	mg/Kg	☼	06/29/19 08:00	07/11/19 12:59	4
Antimony	ND		15	1.4	mg/Kg	☼	06/29/19 08:00	07/11/19 12:59	4
Arsenic	ND		2.5	0.66	mg/Kg	☼	06/29/19 08:00	07/11/19 12:59	4
Barium	0.88	J	13	0.61	mg/Kg	☼	06/29/19 08:00	07/11/19 12:59	4
Beryllium	ND		1.3	0.39	mg/Kg	☼	06/29/19 08:00	07/11/19 12:59	4
Cobalt	1.6	J	13	0.23	mg/Kg	☼	06/29/19 08:00	07/11/19 12:59	4
Iron	23	J	25	15	mg/Kg	☼	06/29/19 08:00	07/11/19 12:59	4
Li	ND		13	0.76	mg/Kg	☼	06/29/19 08:00	07/11/19 12:59	4
Manganese	33		3.8	0.16	mg/Kg	☼	06/29/19 08:00	07/11/19 12:59	4
Mo	ND		10	0.42	mg/Kg	☼	06/29/19 08:00	07/11/19 12:59	4
Selenium	ND		2.5	0.87	mg/Kg	☼	06/29/19 08:00	07/11/19 12:59	4
Thallium	ND		8.9	1.1	mg/Kg	☼	06/29/19 08:00	07/11/19 12:59	4

Method: 6010B SEP - SEP Metals (ICP) - Step 2

Analyte	Result	Qualifier	RL	MDL	Unit	D	Prepared	Analyzed	Dil Fac
Aluminum	18	J *	38	6.1	mg/Kg	☼	06/30/19 08:00	07/11/19 14:42	3
Antimony	ND		11	1.1	mg/Kg	☼	06/30/19 08:00	07/11/19 14:42	3
Arsenic	ND		1.9	0.50	mg/Kg	☼	06/30/19 08:00	07/11/19 14:42	3
Barium	0.67	J *	9.6	0.46	mg/Kg	☼	06/30/19 08:00	07/11/19 14:42	3
Beryllium	ND	*	0.96	0.061	mg/Kg	☼	06/30/19 08:00	07/11/19 14:42	3
Cobalt	0.27	J	9.6	0.24	mg/Kg	☼	06/30/19 08:00	07/11/19 14:42	3
Iron	110	*	19	11	mg/Kg	☼	06/30/19 08:00	07/11/19 14:42	3
Li	ND		9.6	0.57	mg/Kg	☼	06/30/19 08:00	07/11/19 14:42	3
Manganese	4.2		2.9	1.1	mg/Kg	☼	06/30/19 08:00	07/11/19 14:42	3
Mo	ND		7.6	0.31	mg/Kg	☼	06/30/19 08:00	07/11/19 14:42	3
Selenium	0.90	J B	1.9	0.65	mg/Kg	☼	06/30/19 08:00	07/11/19 14:42	3
Thallium	ND		6.7	0.80	mg/Kg	☼	06/30/19 08:00	07/11/19 14:42	3

Method: 6010B SEP - SEP Metals (ICP) - Step 3

Analyte	Result	Qualifier	RL	MDL	Unit	D	Prepared	Analyzed	Dil Fac
Aluminum	97		13	2.7	mg/Kg	☼	07/02/19 08:00	07/11/19 16:16	1
Antimony	ND		3.8	0.36	mg/Kg	☼	07/02/19 08:00	07/11/19 16:16	1
Arsenic	0.97		0.64	0.17	mg/Kg	☼	07/02/19 08:00	07/11/19 16:16	1
Barium	4.1	B	3.2	0.15	mg/Kg	☼	07/02/19 08:00	07/11/19 16:16	1
Beryllium	0.028	J	0.32	0.019	mg/Kg	☼	07/02/19 08:00	07/11/19 16:16	1
Cobalt	0.17	J	3.2	0.057	mg/Kg	☼	07/02/19 08:00	07/11/19 16:16	1
Iron	1100		6.4	3.7	mg/Kg	☼	07/02/19 08:00	07/11/19 16:16	1
Li	ND		3.2	0.19	mg/Kg	☼	07/02/19 08:00	07/11/19 16:16	1
Manganese	1.5	B	0.96	0.034	mg/Kg	☼	07/02/19 08:00	07/11/19 16:16	1
Mo	ND		2.5	0.10	mg/Kg	☼	07/02/19 08:00	07/11/19 16:16	1
Selenium	ND		0.64	0.22	mg/Kg	☼	07/02/19 08:00	07/11/19 16:16	1
Thallium	ND		2.2	0.27	mg/Kg	☼	07/02/19 08:00	07/11/19 16:16	1

Method: 6010B SEP - SEP Metals (ICP) - Step 4

Analyte	Result	Qualifier	RL	MDL	Unit	D	Prepared	Analyzed	Dil Fac
Aluminum	1800		13	2.0	mg/Kg	☼	07/03/19 08:00	07/11/19 17:59	1
Antimony	ND		3.8	0.57	mg/Kg	☼	07/03/19 08:00	07/11/19 17:59	1
Arsenic	0.78	B	0.64	0.28	mg/Kg	☼	07/03/19 08:00	07/11/19 17:59	1
Barium	23		3.2	0.15	mg/Kg	☼	07/03/19 08:00	07/11/19 17:59	1
Beryllium	0.078	J	0.32	0.020	mg/Kg	☼	07/03/19 08:00	07/11/19 17:59	1

Eurofins TestAmerica, Knoxville

Client Sample Results

Client: Golder Associates Inc.
Project/Site: Martin Lake Ash Ponds - SEP + Totals

Job ID: 140-15490-1

Client Sample ID: AP-2019-2 (35-36)

Lab Sample ID: 140-15490-2

Date Collected: 06/03/19 13:20

Matrix: Solid

Date Received: 06/05/19 09:20

Percent Solids: 78.5

Method: 6010B SEP - SEP Metals (ICP) - Step 4 (Continued)

Analyte	Result	Qualifier	RL	MDL	Unit	D	Prepared	Analyzed	Dil Fac
Cobalt	1.5	J	3.2	0.068	mg/Kg	☼	07/03/19 08:00	07/11/19 17:59	1
Iron	3800		6.4	3.7	mg/Kg	☼	07/03/19 08:00	07/11/19 17:59	1
Li	4.2		3.2	0.19	mg/Kg	☼	07/03/19 08:00	07/11/19 17:59	1
Manganese	31		0.96	0.17	mg/Kg	☼	07/03/19 08:00	07/11/19 17:59	1
Mo	ND		2.5	0.10	mg/Kg	☼	07/03/19 08:00	07/11/19 17:59	1
Selenium	ND	*	0.64	0.60	mg/Kg	☼	07/03/19 08:00	07/11/19 17:59	1
Thallium	ND		2.2	0.37	mg/Kg	☼	07/03/19 08:00	07/11/19 17:59	1

Method: 6010B SEP - SEP Metals (ICP) - Step 5

Analyte	Result	Qualifier	RL	MDL	Unit	D	Prepared	Analyzed	Dil Fac
Aluminum	55	J*	190	30	mg/Kg	☼	07/10/19 08:00	07/12/19 12:05	5
Antimony	ND		57	5.4	mg/Kg	☼	07/10/19 08:00	07/12/19 12:05	5
Arsenic	ND		9.6	2.4	mg/Kg	☼	07/10/19 08:00	07/12/19 12:05	5
Barium	11	J*	48	2.3	mg/Kg	☼	07/10/19 08:00	07/12/19 12:05	5
Beryllium	ND	*	4.8	0.40	mg/Kg	☼	07/10/19 08:00	07/12/19 12:05	5
Cobalt	0.85	J*	48	0.76	mg/Kg	☼	07/10/19 08:00	07/12/19 12:05	5
Iron	ND	*	96	56	mg/Kg	☼	07/10/19 08:00	07/12/19 12:05	5
Li	ND		48	2.8	mg/Kg	☼	07/10/19 08:00	07/12/19 12:05	5
Manganese	3.9	J*	14	2.4	mg/Kg	☼	07/10/19 08:00	07/12/19 12:05	5
Mo	ND		38	1.6	mg/Kg	☼	07/10/19 08:00	07/12/19 12:05	5
Selenium	ND		9.6	3.3	mg/Kg	☼	07/10/19 08:00	07/12/19 12:05	5
Thallium	ND	*	33	4.5	mg/Kg	☼	07/10/19 08:00	07/12/19 12:05	5

Method: 6010B SEP - SEP Metals (ICP) - Step 6

Analyte	Result	Qualifier	RL	MDL	Unit	D	Prepared	Analyzed	Dil Fac
Aluminum	2000		13	2.0	mg/Kg	☼	07/10/19 08:00	07/12/19 13:49	1
Antimony	ND		3.8	0.36	mg/Kg	☼	07/10/19 08:00	07/12/19 13:49	1
Arsenic	0.74		0.64	0.19	mg/Kg	☼	07/10/19 08:00	07/12/19 13:49	1
Barium	16		3.2	0.15	mg/Kg	☼	07/10/19 08:00	07/12/19 13:49	1
Beryllium	0.061	J	0.32	0.015	mg/Kg	☼	07/10/19 08:00	07/12/19 13:49	1
Cobalt	0.80	J	3.2	0.059	mg/Kg	☼	07/10/19 08:00	07/12/19 13:49	1
Iron	3300		6.4	3.7	mg/Kg	☼	07/10/19 08:00	07/12/19 13:49	1
Li	2.1	J	3.2	0.19	mg/Kg	☼	07/10/19 08:00	07/12/19 13:49	1
Manganese	19		0.96	0.32	mg/Kg	☼	07/10/19 08:00	07/12/19 13:49	1
Mo	ND		2.5	0.13	mg/Kg	☼	07/10/19 08:00	07/12/19 13:49	1
Selenium	ND		0.64	0.22	mg/Kg	☼	07/10/19 08:00	07/12/19 13:49	1
Thallium	ND		2.2	0.27	mg/Kg	☼	07/10/19 08:00	07/12/19 13:49	1

Method: 6010B SEP - SEP Metals (ICP) - Step 7

Analyte	Result	Qualifier	RL	MDL	Unit	D	Prepared	Analyzed	Dil Fac
Aluminum	26000		130	20	mg/Kg	☼	07/12/19 09:08	07/15/19 13:19	10
Antimony	ND		3.8	0.18	mg/Kg	☼	07/12/19 09:08	07/15/19 12:05	1
Arsenic	0.71		0.64	0.17	mg/Kg	☼	07/12/19 09:08	07/15/19 12:05	1
Barium	330		32	1.5	mg/Kg	☼	07/12/19 09:08	07/15/19 13:19	10
Beryllium	0.51		0.32	0.0096	mg/Kg	☼	07/12/19 09:08	07/15/19 12:05	1
Cobalt	1.1	J	6.4	0.38	mg/Kg	☼	07/12/19 09:08	07/15/19 17:21	2
Iron	5600		6.4	5.2	mg/Kg	☼	07/12/19 09:08	07/15/19 12:05	1
Li	11		3.2	0.19	mg/Kg	☼	07/12/19 09:08	07/15/19 12:05	1
Manganese	34		0.96	0.066	mg/Kg	☼	07/12/19 09:08	07/15/19 12:05	1
Mo	0.17	J	2.5	0.10	mg/Kg	☼	07/12/19 09:08	07/15/19 12:05	1

Eurofins TestAmerica, Knoxville

Client Sample Results

Client: Golder Associates Inc.
Project/Site: Martin Lake Ash Ponds - SEP + Totals

Job ID: 140-15490-1

Client Sample ID: AP-2019-2 (35-36)

Lab Sample ID: 140-15490-2

Date Collected: 06/03/19 13:20

Matrix: Solid

Date Received: 06/05/19 09:20

Percent Solids: 78.5

Method: 6010B SEP - SEP Metals (ICP) - Step 7 (Continued)

Analyte	Result	Qualifier	RL	MDL	Unit	D	Prepared	Analyzed	Dil Fac
Selenium	ND		0.64	0.22	mg/Kg	☼	07/12/19 09:08	07/15/19 12:05	1
Thallium	0.70	J	4.5	0.46	mg/Kg	☼	07/12/19 09:08	07/15/19 17:21	2

Method: 6010B SEP - SEP Metals (ICP) - Sum of Steps 1-7

Analyte	Result	Qualifier	RL	MDL	Unit	D	Prepared	Analyzed	Dil Fac
Aluminum	30000		10	1.6	mg/Kg			07/16/19 17:31	1
Antimony	ND		3.0	0.14	mg/Kg			07/16/19 17:31	1
Arsenic	3.2		0.50	0.13	mg/Kg			07/16/19 17:31	1
Barium	390		2.5	0.12	mg/Kg			07/16/19 17:31	1
Beryllium	0.68		0.25	0.0075	mg/Kg			07/16/19 17:31	1
Cobalt	6.3		2.5	0.023	mg/Kg			07/16/19 17:31	1
Iron	14000		5.0	4.1	mg/Kg			07/16/19 17:31	1
Li	18		2.5	0.15	mg/Kg			07/16/19 17:31	1
Manganese	130		0.75	0.052	mg/Kg			07/16/19 17:31	1
Mo	0.17	J	2.0	0.082	mg/Kg			07/16/19 17:31	1
Selenium	0.90		0.50	0.17	mg/Kg			07/16/19 17:31	1
Thallium	0.70	J	1.8	0.18	mg/Kg			07/16/19 17:31	1

Method: 6010B - Metals (ICP)

Analyte	Result	Qualifier	RL	MDL	Unit	D	Prepared	Analyzed	Dil Fac
Boron	ND		24	12	mg/Kg	☼	06/26/19 08:00	07/10/19 13:13	1
Chromium	12		1.8	0.27	mg/Kg	☼	06/26/19 08:00	07/10/19 13:13	1
Lead	6.2		1.8	0.34	mg/Kg	☼	06/26/19 08:00	07/10/19 13:13	1

Method: 6010B - SEP Metals (ICP) - Total

Analyte	Result	Qualifier	RL	MDL	Unit	D	Prepared	Analyzed	Dil Fac
Aluminum	62000		130	20	mg/Kg	☼	06/11/19 08:00	07/15/19 16:10	10
Antimony	ND		3.8	0.18	mg/Kg	☼	06/11/19 08:00	07/15/19 14:36	1
Arsenic	3.0		0.64	0.17	mg/Kg	☼	06/11/19 08:00	07/15/19 14:36	1
Barium	560		32	1.5	mg/Kg	☼	06/11/19 08:00	07/15/19 16:10	10
Beryllium	0.72		0.32	0.0096	mg/Kg	☼	06/11/19 08:00	07/15/19 14:36	1
Cobalt	6.2	J	16	0.96	mg/Kg	☼	06/11/19 08:00	07/15/19 18:38	5
Iron	13000		6.4	5.2	mg/Kg	☼	06/11/19 08:00	07/15/19 14:36	1
Lithium	26		3.2	0.19	mg/Kg	☼	06/11/19 08:00	07/15/19 14:36	1
Manganese	150		0.96	0.066	mg/Kg	☼	06/11/19 08:00	07/15/19 14:36	1
Molybdenum	0.41	J	2.5	0.10	mg/Kg	☼	06/11/19 08:00	07/15/19 14:36	1
Selenium	ND		0.64	0.22	mg/Kg	☼	06/11/19 08:00	07/15/19 14:36	1
Thallium	ND		11	1.1	mg/Kg	☼	06/11/19 08:00	07/15/19 18:38	5

Method: 7470A - SEP Mercury (CVAA) - Total

Analyte	Result	Qualifier	RL	MDL	Unit	D	Prepared	Analyzed	Dil Fac
Hg	0.12	J	0.13	0.051	mg/Kg	☼	06/11/19 08:00	06/16/19 14:09	1

Client Sample Results

Client: Golder Associates Inc.
Project/Site: Martin Lake Ash Ponds - SEP + Totals

Job ID: 140-15490-1

Client Sample ID: AP-2019-3 (18-19)

Lab Sample ID: 140-15490-3

Date Collected: 06/03/19 15:20

Matrix: Solid

Date Received: 06/05/19 09:20

Percent Solids: 80.0

Method: 6010B SEP - SEP Metals (ICP) - Step 1

Analyte	Result	Qualifier	RL	MDL	Unit	D	Prepared	Analyzed	Dil Fac
Aluminum	14	J	50	8.0	mg/Kg	☼	06/29/19 08:00	07/11/19 13:04	4
Antimony	ND		15	1.4	mg/Kg	☼	06/29/19 08:00	07/11/19 13:04	4
Arsenic	ND		2.5	0.65	mg/Kg	☼	06/29/19 08:00	07/11/19 13:04	4
Barium	ND		13	0.60	mg/Kg	☼	06/29/19 08:00	07/11/19 13:04	4
Beryllium	ND		1.3	0.39	mg/Kg	☼	06/29/19 08:00	07/11/19 13:04	4
Cobalt	0.87	J	13	0.23	mg/Kg	☼	06/29/19 08:00	07/11/19 13:04	4
Iron	15	J	25	15	mg/Kg	☼	06/29/19 08:00	07/11/19 13:04	4
Li	ND		13	0.75	mg/Kg	☼	06/29/19 08:00	07/11/19 13:04	4
Manganese	1.2	J	3.8	0.16	mg/Kg	☼	06/29/19 08:00	07/11/19 13:04	4
Mo	ND		10	0.41	mg/Kg	☼	06/29/19 08:00	07/11/19 13:04	4
Selenium	ND		2.5	0.85	mg/Kg	☼	06/29/19 08:00	07/11/19 13:04	4
Thallium	ND		8.8	1.1	mg/Kg	☼	06/29/19 08:00	07/11/19 13:04	4

Method: 6010B SEP - SEP Metals (ICP) - Step 2

Analyte	Result	Qualifier	RL	MDL	Unit	D	Prepared	Analyzed	Dil Fac
Aluminum	ND	*	38	6.0	mg/Kg	☼	06/30/19 08:00	07/11/19 14:47	3
Antimony	ND		11	1.1	mg/Kg	☼	06/30/19 08:00	07/11/19 14:47	3
Arsenic	ND		1.9	0.49	mg/Kg	☼	06/30/19 08:00	07/11/19 14:47	3
Barium	ND	*	9.4	0.45	mg/Kg	☼	06/30/19 08:00	07/11/19 14:47	3
Beryllium	ND	*	0.94	0.060	mg/Kg	☼	06/30/19 08:00	07/11/19 14:47	3
Cobalt	ND		9.4	0.24	mg/Kg	☼	06/30/19 08:00	07/11/19 14:47	3
Iron	ND	*	19	11	mg/Kg	☼	06/30/19 08:00	07/11/19 14:47	3
Li	ND		9.4	0.56	mg/Kg	☼	06/30/19 08:00	07/11/19 14:47	3
Manganese	ND		2.8	1.1	mg/Kg	☼	06/30/19 08:00	07/11/19 14:47	3
Mo	ND		7.5	0.31	mg/Kg	☼	06/30/19 08:00	07/11/19 14:47	3
Selenium	0.68	J B	1.9	0.64	mg/Kg	☼	06/30/19 08:00	07/11/19 14:47	3
Thallium	ND		6.6	0.79	mg/Kg	☼	06/30/19 08:00	07/11/19 14:47	3

Method: 6010B SEP - SEP Metals (ICP) - Step 3

Analyte	Result	Qualifier	RL	MDL	Unit	D	Prepared	Analyzed	Dil Fac
Aluminum	30		13	2.6	mg/Kg	☼	07/02/19 08:00	07/11/19 16:21	1
Antimony	ND		3.8	0.35	mg/Kg	☼	07/02/19 08:00	07/11/19 16:21	1
Arsenic	ND		0.63	0.16	mg/Kg	☼	07/02/19 08:00	07/11/19 16:21	1
Barium	2.3	J B	3.1	0.15	mg/Kg	☼	07/02/19 08:00	07/11/19 16:21	1
Beryllium	0.025	J	0.31	0.019	mg/Kg	☼	07/02/19 08:00	07/11/19 16:21	1
Cobalt	ND		3.1	0.056	mg/Kg	☼	07/02/19 08:00	07/11/19 16:21	1
Iron	57		6.3	3.6	mg/Kg	☼	07/02/19 08:00	07/11/19 16:21	1
Li	ND		3.1	0.19	mg/Kg	☼	07/02/19 08:00	07/11/19 16:21	1
Manganese	0.11	J B	0.94	0.034	mg/Kg	☼	07/02/19 08:00	07/11/19 16:21	1
Mo	ND		2.5	0.10	mg/Kg	☼	07/02/19 08:00	07/11/19 16:21	1
Selenium	0.23	J B	0.63	0.21	mg/Kg	☼	07/02/19 08:00	07/11/19 16:21	1
Thallium	ND		2.2	0.26	mg/Kg	☼	07/02/19 08:00	07/11/19 16:21	1

Method: 6010B SEP - SEP Metals (ICP) - Step 4

Analyte	Result	Qualifier	RL	MDL	Unit	D	Prepared	Analyzed	Dil Fac
Aluminum	880		13	2.0	mg/Kg	☼	07/03/19 08:00	07/11/19 18:04	1
Antimony	ND		3.8	0.56	mg/Kg	☼	07/03/19 08:00	07/11/19 18:04	1
Arsenic	0.63	B	0.63	0.28	mg/Kg	☼	07/03/19 08:00	07/11/19 18:04	1
Barium	6.9		3.1	0.15	mg/Kg	☼	07/03/19 08:00	07/11/19 18:04	1
Beryllium	0.069	J	0.31	0.020	mg/Kg	☼	07/03/19 08:00	07/11/19 18:04	1

Eurofins TestAmerica, Knoxville

Client Sample Results

Client: Golder Associates Inc.
Project/Site: Martin Lake Ash Ponds - SEP + Totals

Job ID: 140-15490-1

Client Sample ID: AP-2019-3 (18-19)

Lab Sample ID: 140-15490-3

Date Collected: 06/03/19 15:20

Matrix: Solid

Date Received: 06/05/19 09:20

Percent Solids: 80.0

Method: 6010B SEP - SEP Metals (ICP) - Step 4 (Continued)

Analyte	Result	Qualifier	RL	MDL	Unit	D	Prepared	Analyzed	Dil Fac
Cobalt	0.53	J	3.1	0.066	mg/Kg	☼	07/03/19 08:00	07/11/19 18:04	1
Iron	2300		6.3	3.6	mg/Kg	☼	07/03/19 08:00	07/11/19 18:04	1
Li	0.53	J	3.1	0.19	mg/Kg	☼	07/03/19 08:00	07/11/19 18:04	1
Manganese	4.2		0.94	0.16	mg/Kg	☼	07/03/19 08:00	07/11/19 18:04	1
Mo	ND		2.5	0.10	mg/Kg	☼	07/03/19 08:00	07/11/19 18:04	1
Selenium	0.65	B *	0.63	0.59	mg/Kg	☼	07/03/19 08:00	07/11/19 18:04	1
Thallium	ND		2.2	0.36	mg/Kg	☼	07/03/19 08:00	07/11/19 18:04	1

Method: 6010B SEP - SEP Metals (ICP) - Step 5

Analyte	Result	Qualifier	RL	MDL	Unit	D	Prepared	Analyzed	Dil Fac
Aluminum	120	J *	190	29	mg/Kg	☼	07/10/19 08:00	07/12/19 12:10	5
Antimony	ND		56	5.3	mg/Kg	☼	07/10/19 08:00	07/12/19 12:10	5
Arsenic	ND		9.4	2.4	mg/Kg	☼	07/10/19 08:00	07/12/19 12:10	5
Barium	ND	*	47	2.3	mg/Kg	☼	07/10/19 08:00	07/12/19 12:10	5
Beryllium	ND	*	4.7	0.39	mg/Kg	☼	07/10/19 08:00	07/12/19 12:10	5
Cobalt	ND	*	47	0.75	mg/Kg	☼	07/10/19 08:00	07/12/19 12:10	5
Iron	ND	*	94	55	mg/Kg	☼	07/10/19 08:00	07/12/19 12:10	5
Li	ND		47	2.8	mg/Kg	☼	07/10/19 08:00	07/12/19 12:10	5
Manganese	ND	*	14	2.3	mg/Kg	☼	07/10/19 08:00	07/12/19 12:10	5
Mo	ND		38	1.6	mg/Kg	☼	07/10/19 08:00	07/12/19 12:10	5
Selenium	ND		9.4	3.3	mg/Kg	☼	07/10/19 08:00	07/12/19 12:10	5
Thallium	ND	*	33	4.4	mg/Kg	☼	07/10/19 08:00	07/12/19 12:10	5

Method: 6010B SEP - SEP Metals (ICP) - Step 6

Analyte	Result	Qualifier	RL	MDL	Unit	D	Prepared	Analyzed	Dil Fac
Aluminum	1200		13	2.0	mg/Kg	☼	07/10/19 08:00	07/12/19 13:55	1
Antimony	ND		3.8	0.35	mg/Kg	☼	07/10/19 08:00	07/12/19 13:55	1
Arsenic	0.24	J	0.63	0.19	mg/Kg	☼	07/10/19 08:00	07/12/19 13:55	1
Barium	2.1	J	3.1	0.15	mg/Kg	☼	07/10/19 08:00	07/12/19 13:55	1
Beryllium	0.026	J	0.31	0.015	mg/Kg	☼	07/10/19 08:00	07/12/19 13:55	1
Cobalt	0.28	J	3.1	0.058	mg/Kg	☼	07/10/19 08:00	07/12/19 13:55	1
Iron	820		6.3	3.6	mg/Kg	☼	07/10/19 08:00	07/12/19 13:55	1
Li	0.62	J	3.1	0.19	mg/Kg	☼	07/10/19 08:00	07/12/19 13:55	1
Manganese	2.9		0.94	0.31	mg/Kg	☼	07/10/19 08:00	07/12/19 13:55	1
Mo	ND		2.5	0.12	mg/Kg	☼	07/10/19 08:00	07/12/19 13:55	1
Selenium	ND		0.63	0.21	mg/Kg	☼	07/10/19 08:00	07/12/19 13:55	1
Thallium	ND		2.2	0.26	mg/Kg	☼	07/10/19 08:00	07/12/19 13:55	1

Method: 6010B SEP - SEP Metals (ICP) - Step 7

Analyte	Result	Qualifier	RL	MDL	Unit	D	Prepared	Analyzed	Dil Fac
Aluminum	12000		130	20	mg/Kg	☼	07/12/19 09:08	07/15/19 13:24	10
Antimony	ND		3.8	0.18	mg/Kg	☼	07/12/19 09:08	07/15/19 12:11	1
Arsenic	0.79	J	1.3	0.33	mg/Kg	☼	07/12/19 09:08	07/15/19 17:27	2
Barium	180		31	1.5	mg/Kg	☼	07/12/19 09:08	07/15/19 13:24	10
Beryllium	0.11	J	0.31	0.0094	mg/Kg	☼	07/12/19 09:08	07/15/19 12:11	1
Cobalt	ND		6.3	0.38	mg/Kg	☼	07/12/19 09:08	07/15/19 17:27	2
Iron	2000		6.3	5.1	mg/Kg	☼	07/12/19 09:08	07/15/19 12:11	1
Li	6.0		3.1	0.19	mg/Kg	☼	07/12/19 09:08	07/15/19 12:11	1
Manganese	26		0.94	0.065	mg/Kg	☼	07/12/19 09:08	07/15/19 12:11	1
Mo	0.12	J	2.5	0.10	mg/Kg	☼	07/12/19 09:08	07/15/19 12:11	1

Eurofins TestAmerica, Knoxville

Client Sample Results

Client: Golder Associates Inc.
Project/Site: Martin Lake Ash Ponds - SEP + Totals

Job ID: 140-15490-1

Client Sample ID: AP-2019-3 (18-19)

Lab Sample ID: 140-15490-3

Date Collected: 06/03/19 15:20

Matrix: Solid

Date Received: 06/05/19 09:20

Percent Solids: 80.0

Method: 6010B SEP - SEP Metals (ICP) - Step 7 (Continued)

Analyte	Result	Qualifier	RL	MDL	Unit	D	Prepared	Analyzed	Dil Fac
Selenium	ND		1.3	0.43	mg/Kg	☼	07/12/19 09:08	07/15/19 17:27	2
Thallium	ND		4.4	0.45	mg/Kg	☼	07/12/19 09:08	07/15/19 17:27	2

Method: 6010B SEP - SEP Metals (ICP) - Sum of Steps 1-7

Analyte	Result	Qualifier	RL	MDL	Unit	D	Prepared	Analyzed	Dil Fac
Aluminum	14000		10	1.6	mg/Kg			07/16/19 17:31	1
Antimony	ND		3.0	0.14	mg/Kg			07/16/19 17:31	1
Arsenic	1.7		0.50	0.13	mg/Kg			07/16/19 17:31	1
Barium	190		2.5	0.12	mg/Kg			07/16/19 17:31	1
Beryllium	0.23	J	0.25	0.0075	mg/Kg			07/16/19 17:31	1
Cobalt	1.7	J	2.5	0.023	mg/Kg			07/16/19 17:31	1
Iron	5200		5.0	4.1	mg/Kg			07/16/19 17:31	1
Li	7.2		2.5	0.15	mg/Kg			07/16/19 17:31	1
Manganese	35		0.75	0.052	mg/Kg			07/16/19 17:31	1
Mo	0.12	J	2.0	0.082	mg/Kg			07/16/19 17:31	1
Selenium	1.6		0.50	0.17	mg/Kg			07/16/19 17:31	1
Thallium	ND		1.8	0.18	mg/Kg			07/16/19 17:31	1

Method: 6010B - Metals (ICP)

Analyte	Result	Qualifier	RL	MDL	Unit	D	Prepared	Analyzed	Dil Fac
Boron	ND		24	12	mg/Kg	☼	06/26/19 08:00	07/10/19 13:18	1
Chromium	4.4		1.8	0.26	mg/Kg	☼	06/26/19 08:00	07/10/19 13:18	1
Lead	3.9		1.8	0.33	mg/Kg	☼	06/26/19 08:00	07/10/19 13:18	1

Method: 6010B - SEP Metals (ICP) - Total

Analyte	Result	Qualifier	RL	MDL	Unit	D	Prepared	Analyzed	Dil Fac
Aluminum	20000		130	20	mg/Kg	☼	06/11/19 08:00	07/15/19 16:15	10
Antimony	ND		3.8	0.18	mg/Kg	☼	06/11/19 08:00	07/15/19 14:41	1
Arsenic	2.9	J	3.1	0.81	mg/Kg	☼	06/11/19 08:00	07/15/19 18:43	5
Barium	240		31	1.5	mg/Kg	☼	06/11/19 08:00	07/15/19 16:15	10
Beryllium	0.42		0.31	0.0094	mg/Kg	☼	06/11/19 08:00	07/15/19 14:41	1
Cobalt	3.3	J	16	0.94	mg/Kg	☼	06/11/19 08:00	07/15/19 18:43	5
Iron	8000		6.3	5.1	mg/Kg	☼	06/11/19 08:00	07/15/19 14:41	1
Lithium	9.6		3.1	0.19	mg/Kg	☼	06/11/19 08:00	07/15/19 14:41	1
Manganese	47		0.94	0.065	mg/Kg	☼	06/11/19 08:00	07/15/19 14:41	1
Molybdenum	0.28	J	2.5	0.10	mg/Kg	☼	06/11/19 08:00	07/15/19 14:41	1
Selenium	ND		3.1	1.1	mg/Kg	☼	06/11/19 08:00	07/15/19 18:43	5
Thallium	ND		11	1.1	mg/Kg	☼	06/11/19 08:00	07/15/19 18:43	5

Method: 7470A - SEP Mercury (CVAA) - Total

Analyte	Result	Qualifier	RL	MDL	Unit	D	Prepared	Analyzed	Dil Fac
Hg	ND		0.13	0.050	mg/Kg	☼	06/11/19 08:00	06/16/19 14:17	1

Default Detection Limits

Client: Golder Associates Inc.
Project/Site: Martin Lake Ash Ponds - SEP + Totals

Job ID: 140-15490-1

Method: 6010B SEP - SEP Metals (ICP) - Step 1

Prep: 3010A

SEP: Exchangeable

Analyte	RL	MDL	Units
Aluminum	10	1.6	mg/Kg
Antimony	3.0	0.28	mg/Kg
Arsenic	0.50	0.13	mg/Kg
Barium	2.5	0.12	mg/Kg
Beryllium	0.25	0.077	mg/Kg
Cobalt	2.5	0.045	mg/Kg
Iron	5.0	2.9	mg/Kg
Li	2.5	0.15	mg/Kg
Manganese	0.75	0.031	mg/Kg
Mo	2.0	0.082	mg/Kg
Selenium	0.50	0.17	mg/Kg
Thallium	1.8	0.21	mg/Kg

Method: 6010B SEP - SEP Metals (ICP) - Step 2

Prep: 3010A

SEP: Carbonate

Analyte	RL	MDL	Units
Aluminum	10	1.6	mg/Kg
Antimony	3.0	0.28	mg/Kg
Arsenic	0.50	0.13	mg/Kg
Barium	2.5	0.12	mg/Kg
Beryllium	0.25	0.016	mg/Kg
Cobalt	2.5	0.063	mg/Kg
Iron	5.0	2.9	mg/Kg
Li	2.5	0.15	mg/Kg
Manganese	0.75	0.28	mg/Kg
Mo	2.0	0.082	mg/Kg
Selenium	0.50	0.17	mg/Kg
Thallium	1.8	0.21	mg/Kg

Method: 6010B SEP - SEP Metals (ICP) - Step 3

Prep: 3010A

SEP: Non-Crystalline

Analyte	RL	MDL	Units
Aluminum	10	2.1	mg/Kg
Antimony	3.0	0.28	mg/Kg
Arsenic	0.50	0.13	mg/Kg
Barium	2.5	0.12	mg/Kg
Beryllium	0.25	0.015	mg/Kg
Cobalt	2.5	0.045	mg/Kg
Iron	5.0	2.9	mg/Kg
Li	2.5	0.15	mg/Kg
Manganese	0.75	0.027	mg/Kg
Mo	2.0	0.082	mg/Kg
Selenium	0.50	0.17	mg/Kg
Thallium	1.8	0.21	mg/Kg

Method: 6010B SEP - SEP Metals (ICP) - Step 4

Prep: 3010A

SEP: Metal Hydroxide

Default Detection Limits

Client: Golder Associates Inc.
 Project/Site: Martin Lake Ash Ponds - SEP + Totals

Job ID: 140-15490-1

Method: 6010B SEP - SEP Metals (ICP) - Step 4

Prep: 3010A

SEP: Metal Hydroxide

Analyte	RL	MDL	Units
Aluminum	10	1.6	mg/Kg
Antimony	3.0	0.45	mg/Kg
Arsenic	0.50	0.22	mg/Kg
Barium	2.5	0.12	mg/Kg
Beryllium	0.25	0.016	mg/Kg
Cobalt	2.5	0.053	mg/Kg
Iron	5.0	2.9	mg/Kg
Li	2.5	0.15	mg/Kg
Manganese	0.75	0.13	mg/Kg
Mo	2.0	0.082	mg/Kg
Selenium	0.50	0.47	mg/Kg
Thallium	1.8	0.29	mg/Kg

Method: 6010B SEP - SEP Metals (ICP) - Step 5

Prep: 3010A

SEP: Organic-Bound

Analyte	RL	MDL	Units
Aluminum	30	4.7	mg/Kg
Antimony	9.0	0.84	mg/Kg
Arsenic	1.5	0.38	mg/Kg
Barium	7.5	0.36	mg/Kg
Beryllium	0.75	0.063	mg/Kg
Cobalt	7.5	0.12	mg/Kg
Iron	15	8.8	mg/Kg
Li	7.5	0.44	mg/Kg
Manganese	2.3	0.37	mg/Kg
Mo	6.0	0.25	mg/Kg
Selenium	1.5	0.52	mg/Kg
Thallium	5.3	0.70	mg/Kg

Method: 6010B SEP - SEP Metals (ICP) - Step 6

SEP: Acid/Sulfide

Analyte	RL	MDL	Units
Aluminum	10	1.6	mg/Kg
Antimony	3.0	0.28	mg/Kg
Arsenic	0.50	0.15	mg/Kg
Barium	2.5	0.12	mg/Kg
Beryllium	0.25	0.012	mg/Kg
Cobalt	2.5	0.046	mg/Kg
Iron	5.0	2.9	mg/Kg
Li	2.5	0.15	mg/Kg
Manganese	0.75	0.25	mg/Kg
Mo	2.0	0.099	mg/Kg
Selenium	0.50	0.17	mg/Kg
Thallium	1.8	0.21	mg/Kg

Method: 6010B SEP - SEP Metals (ICP) - Step 7

Prep: Residual

Analyte	RL	MDL	Units
Aluminum	10	1.6	mg/Kg

Default Detection Limits

Client: Golder Associates Inc.
 Project/Site: Martin Lake Ash Ponds - SEP + Totals

Job ID: 140-15490-1

Method: 6010B SEP - SEP Metals (ICP) - Step 7 (Continued)

Prep: Residual

Analyte	RL	MDL	Units
Antimony	3.0	0.14	mg/Kg
Arsenic	0.50	0.13	mg/Kg
Barium	2.5	0.12	mg/Kg
Beryllium	0.25	0.0075	mg/Kg
Cobalt	2.5	0.15	mg/Kg
Iron	5.0	4.1	mg/Kg
Li	2.5	0.15	mg/Kg
Manganese	0.75	0.052	mg/Kg
Mo	2.0	0.082	mg/Kg
Selenium	0.50	0.17	mg/Kg
Thallium	1.8	0.18	mg/Kg

Method: 6010B SEP - SEP Metals (ICP) - Sum of Steps 1-7

Analyte	RL	MDL	Units
Aluminum	10	1.6	mg/Kg
Antimony	3.0	0.14	mg/Kg
Arsenic	0.50	0.13	mg/Kg
Barium	2.5	0.12	mg/Kg
Beryllium	0.25	0.0075	mg/Kg
Cobalt	2.5	0.023	mg/Kg
Iron	5.0	4.1	mg/Kg
Li	2.5	0.15	mg/Kg
Manganese	0.75	0.052	mg/Kg
Mo	2.0	0.082	mg/Kg
Selenium	0.50	0.17	mg/Kg
Thallium	1.8	0.18	mg/Kg

Method: 6010B - Metals (ICP)

Prep: 3050B

Analyte	RL	MDL	Units
Boron	20	10	mg/Kg
Chromium	1.5	0.22	mg/Kg
Lead	1.5	0.28	mg/Kg

Method: 6010B - SEP Metals (ICP) - Total

Prep: Total

Analyte	RL	MDL	Units
Aluminum	10	1.6	mg/Kg
Antimony	3.0	0.14	mg/Kg
Arsenic	0.50	0.13	mg/Kg
Barium	2.5	0.12	mg/Kg
Beryllium	0.25	0.0075	mg/Kg
Cobalt	2.5	0.15	mg/Kg
Iron	5.0	4.1	mg/Kg
Lithium	2.5	0.15	mg/Kg
Manganese	0.75	0.052	mg/Kg
Molybdenum	2.0	0.082	mg/Kg
Selenium	0.50	0.17	mg/Kg
Thallium	1.8	0.18	mg/Kg

Method: 7470A - SEP Mercury (CVAA) - Total

Eurofins TestAmerica, Knoxville

Default Detection Limits

Client: Golder Associates Inc.
Project/Site: Martin Lake Ash Ponds - SEP + Totals

Job ID: 140-15490-1

Method: 7470A - SEP Mercury (CVAA) - Total
Prep: Total

Analyte	RL	MDL	Units
Hg	0.10	0.040	mg/Kg

LUMINANT

- 1
- 2
- 3
- 4
- 5
- 6
- 7
- 8
- 9
- 10
- 11
- 12
- 13

QC Sample Results

Client: Golder Associates Inc.
 Project/Site: Martin Lake Ash Ponds - SEP + Totals

Job ID: 140-15490-1

Method: 6010B - Metals (ICP)

Lab Sample ID: MB 140-31128/14-A
Matrix: Solid
Analysis Batch: 31553

Client Sample ID: Method Blank
Prep Type: Total/NA
Prep Batch: 31128

Analyte	MB Result	MB Qualifier	RL	MDL	Unit	D	Prepared	Analyzed	Dil Fac
Boron	ND		20	10	mg/Kg		06/26/19 08:00	07/10/19 11:42	1
Chromium	ND		1.5	0.22	mg/Kg		06/26/19 08:00	07/10/19 11:42	1
Lead	ND		1.5	0.28	mg/Kg		06/26/19 08:00	07/10/19 11:42	1

Lab Sample ID: LCS 140-31128/15-A
Matrix: Solid
Analysis Batch: 31553

Client Sample ID: Lab Control Sample
Prep Type: Total/NA
Prep Batch: 31128

Analyte	Spike Added	LCS Result	LCS Qualifier	Unit	D	%Rec	%Rec. Limits
Boron	100	101		mg/Kg		101	80 - 120
Chromium	20.0	20.3		mg/Kg		101	90 - 110
Lead	10.0	10.1		mg/Kg		101	90 - 110

Lab Sample ID: 140-15490-1 MS
Matrix: Solid
Analysis Batch: 31553

Client Sample ID: AP-2019-1 (30-31)
Prep Type: Total/NA
Prep Batch: 31128

Analyte	Sample Result	Sample Qualifier	Spike Added	MS Result	MS Qualifier	Unit	D	%Rec	%Rec. Limits
Boron	ND		124	124		mg/Kg	☼	100	75 - 125
Chromium	13	F1	24.8	45.6	F1	mg/Kg	☼	131	75 - 125
Lead	6.4		12.4	17.4		mg/Kg	☼	89	75 - 125

Lab Sample ID: 140-15490-1 MSD
Matrix: Solid
Analysis Batch: 31553

Client Sample ID: AP-2019-1 (30-31)
Prep Type: Total/NA
Prep Batch: 31128

Analyte	Sample Result	Sample Qualifier	Spike Added	MSD Result	MSD Qualifier	Unit	D	%Rec	%Rec. Limits	RPD	Limit
Boron	ND		122	123		mg/Kg	☼	101	75 - 125	0	20
Chromium	13	F1	24.4	45.6	F1	mg/Kg	☼	133	75 - 125	0	20
Lead	6.4		12.2	17.5		mg/Kg	☼	91	75 - 125	0	20

Method: 6010B - SEP Metals (ICP) - Total

Lab Sample ID: MB 140-30683/13-A
Matrix: Solid
Analysis Batch: 31713

Client Sample ID: Method Blank
Prep Type: Total/NA
Prep Batch: 30683

Analyte	MB Result	MB Qualifier	RL	MDL	Unit	D	Prepared	Analyzed	Dil Fac
Aluminum	ND		10	1.6	mg/Kg		06/11/19 08:00	07/15/19 11:13	1
Antimony	ND		3.0	0.14	mg/Kg		06/11/19 08:00	07/15/19 11:13	1
Arsenic	ND		0.50	0.13	mg/Kg		06/11/19 08:00	07/15/19 11:13	1
Barium	ND		2.5	0.12	mg/Kg		06/11/19 08:00	07/15/19 11:13	1
Beryllium	ND		0.25	0.0075	mg/Kg		06/11/19 08:00	07/15/19 11:13	1
Cobalt	ND		2.5	0.15	mg/Kg		06/11/19 08:00	07/15/19 11:13	1
Iron	ND		5.0	4.1	mg/Kg		06/11/19 08:00	07/15/19 11:13	1
Lithium	ND		2.5	0.15	mg/Kg		06/11/19 08:00	07/15/19 11:13	1
Manganese	ND		0.75	0.052	mg/Kg		06/11/19 08:00	07/15/19 11:13	1
Molybdenum	ND		2.0	0.082	mg/Kg		06/11/19 08:00	07/15/19 11:13	1
Selenium	ND		0.50	0.17	mg/Kg		06/11/19 08:00	07/15/19 11:13	1
Thallium	ND		1.8	0.18	mg/Kg		06/11/19 08:00	07/15/19 11:13	1

Eurofins TestAmerica, Knoxville

QC Sample Results

Client: Golder Associates Inc.
 Project/Site: Martin Lake Ash Ponds - SEP + Totals

Job ID: 140-15490-1

Method: 6010B - SEP Metals (ICP) - Total

Lab Sample ID: LCS 140-30683/14-A
Matrix: Solid
Analysis Batch: 31713

Client Sample ID: Lab Control Sample
Prep Type: Total/NA
Prep Batch: 30683

Analyte	Spike Added	LCS Result	LCS Qualifier	Unit	D	%Rec	%Rec. Limits
Aluminum	100	97.6		mg/Kg		98	75 - 125
Antimony	25.0	25.9		mg/Kg		103	75 - 125
Arsenic	5.00	5.29		mg/Kg		106	75 - 125
Barium	5.00	4.99		mg/Kg		100	75 - 125
Beryllium	2.50	2.51		mg/Kg		100	75 - 125
Cobalt	5.00	5.20		mg/Kg		104	75 - 125
Iron	50.0	51.1		mg/Kg		102	75 - 125
Lithium	5.00	5.12		mg/Kg		102	75 - 125
Manganese	5.00	5.21		mg/Kg		104	75 - 125
Molybdenum	25.0	26.6		mg/Kg		106	75 - 125
Selenium	7.50	7.55		mg/Kg		101	75 - 125
Thallium	20.0	21.2		mg/Kg		106	75 - 125

Lab Sample ID: LCSD 140-30683/15-A
Matrix: Solid
Analysis Batch: 31713

Client Sample ID: Lab Control Sample Dup
Prep Type: Total/NA
Prep Batch: 30683

Analyte	Spike Added	LCSD Result	LCSD Qualifier	Unit	D	%Rec	%Rec. Limits	RPD	RPD Limit
Aluminum	100	97.0		mg/Kg		97	75 - 125	1	30
Antimony	25.0	25.9		mg/Kg		104	75 - 125	0	30
Arsenic	5.00	5.24		mg/Kg		105	75 - 125	1	30
Barium	5.00	4.95		mg/Kg		99	75 - 125	1	30
Beryllium	2.50	2.48		mg/Kg		99	75 - 125	1	30
Cobalt	5.00	5.16		mg/Kg		103	75 - 125	1	30
Iron	50.0	50.4		mg/Kg		101	75 - 125	1	30
Lithium	5.00	5.04		mg/Kg		101	75 - 125	2	30
Manganese	5.00	5.16		mg/Kg		103	75 - 125	1	30
Molybdenum	25.0	26.5		mg/Kg		106	75 - 125	0	30
Selenium	7.50	7.47		mg/Kg		100	75 - 125	1	30
Thallium	20.0	21.2		mg/Kg		106	75 - 125	0	30

Lab Sample ID: 140-15490-1 DU
Matrix: Solid
Analysis Batch: 31713

Client Sample ID: AP-2019-1 (30-31)
Prep Type: Total/NA
Prep Batch: 30683

Analyte	Sample Result	Sample Qualifier	DU Result	DU Qualifier	Unit	D	RPD	RPD Limit
Antimony	ND		ND		mg/Kg	⊛	NC	30
Arsenic	6.8		7.11		mg/Kg	⊛	5	30
Beryllium	0.89		0.959		mg/Kg	⊛	7	30
Iron	11000		12200		mg/Kg	⊛	7	30
Lithium	18		19.7		mg/Kg	⊛	7	30
Manganese	66		71.7		mg/Kg	⊛	8	30
Molybdenum	0.40 J		0.434 J		mg/Kg	⊛	7	30
Selenium	ND		ND		mg/Kg	⊛	NC	30

QC Sample Results

Client: Golder Associates Inc.
 Project/Site: Martin Lake Ash Ponds - SEP + Totals

Job ID: 140-15490-1

Method: 6010B - SEP Metals (ICP) - Total (Continued)

Lab Sample ID: 140-15490-1 DU
Matrix: Solid
Analysis Batch: 31713

Client Sample ID: AP-2019-1 (30-31)
Prep Type: Total/NA
Prep Batch: 30683

Analyte	Sample	Sample	DU	DU	Unit	D	RPD	Limit
	Result	Qualifier	Result	Qualifier				
Aluminum	60000		64600		mg/Kg	☼	7	30
Barium	680		733		mg/Kg	☼	7	30

Lab Sample ID: 140-15490-1 DU
Matrix: Solid
Analysis Batch: 31713

Client Sample ID: AP-2019-1 (30-31)
Prep Type: Total/NA
Prep Batch: 30683

Analyte	Sample	Sample	DU	DU	Unit	D	RPD	Limit
	Result	Qualifier	Result	Qualifier				
Cobalt	3.8	J	4.35	J	mg/Kg	☼	13	30
Thallium	ND		0.657	J	mg/Kg	☼	NC	30

Method: 6010B SEP - SEP Metals (ICP)

Lab Sample ID: MB 140-31148/13-B ^4
Matrix: Solid
Analysis Batch: 31604

Client Sample ID: Method Blank
Prep Type: Step 1
Prep Batch: 31252

Analyte	MB	MB	RL	MDL	Unit	D	Prepared	Analyzed	Dil Fac
	Result	Qualifier							
Aluminum	ND		40	6.4	mg/Kg		06/29/19 08:00	07/11/19 12:33	4
Antimony	ND		12	1.1	mg/Kg		06/29/19 08:00	07/11/19 12:33	4
Arsenic	ND		2.0	0.52	mg/Kg		06/29/19 08:00	07/11/19 12:33	4
Barium	ND		10	0.48	mg/Kg		06/29/19 08:00	07/11/19 12:33	4
Beryllium	ND		1.0	0.31	mg/Kg		06/29/19 08:00	07/11/19 12:33	4
Cobalt	ND		10	0.18	mg/Kg		06/29/19 08:00	07/11/19 12:33	4
Iron	ND		20	12	mg/Kg		06/29/19 08:00	07/11/19 12:33	4
Li	ND		10	0.60	mg/Kg		06/29/19 08:00	07/11/19 12:33	4
Manganese	ND		3.0	0.12	mg/Kg		06/29/19 08:00	07/11/19 12:33	4
Mo	ND		8.0	0.33	mg/Kg		06/29/19 08:00	07/11/19 12:33	4
Selenium	ND		2.0	0.68	mg/Kg		06/29/19 08:00	07/11/19 12:33	4
Thallium	ND		7.0	0.84	mg/Kg		06/29/19 08:00	07/11/19 12:33	4

Lab Sample ID: LCS 140-31148/14-B ^5
Matrix: Solid
Analysis Batch: 31604

Client Sample ID: Lab Control Sample
Prep Type: Step 1
Prep Batch: 31252

Analyte	Spike Added	LCS Result	LCS Qualifier	Unit	D	%Rec	%Rec. Limits
Antimony	25.0	24.5		mg/Kg		98	75 - 125
Arsenic	5.00	4.89		mg/Kg		98	75 - 125
Barium	5.00	4.35	J	mg/Kg		87	75 - 125
Beryllium	2.50	2.58		mg/Kg		103	75 - 125
Cobalt	5.00	4.93	J	mg/Kg		99	75 - 125
Iron	50.0	49.6		mg/Kg		99	75 - 125
Li	5.00	4.72	J	mg/Kg		94	75 - 125
Manganese	5.00	5.09		mg/Kg		102	75 - 125
Mo	25.0	25.0		mg/Kg		100	75 - 125
Selenium	7.50	7.82		mg/Kg		104	75 - 125
Thallium	20.0	19.7		mg/Kg		98	75 - 125

QC Sample Results

Client: Golder Associates Inc.
Project/Site: Martin Lake Ash Ponds - SEP + Totals

Job ID: 140-15490-1

Method: 6010B SEP - SEP Metals (ICP) (Continued)

Lab Sample ID: LCSD 140-31148/15-B ^5
Matrix: Solid
Analysis Batch: 31604

Client Sample ID: Lab Control Sample Dup
Prep Type: Step 1
Prep Batch: 31252

Analyte	Spike Added	LCSD Result	LCSD Qualifier	Unit	D	%Rec	%Rec. Limits	RPD	
								RPD	Limit
Aluminum	100	99.5		mg/Kg		100	75 - 125	3	30
Antimony	25.0	24.7		mg/Kg		99	75 - 125	1	30
Arsenic	5.00	4.78		mg/Kg		96	75 - 125	2	30
Barium	5.00	4.30	J	mg/Kg		86	75 - 125	1	30
Beryllium	2.50	2.59		mg/Kg		104	75 - 125	0	30
Cobalt	5.00	4.89	J	mg/Kg		98	75 - 125	1	30
Iron	50.0	49.5		mg/Kg		99	75 - 125	0	30
Li	5.00	4.84	J	mg/Kg		97	75 - 125	3	30
Manganese	5.00	5.06		mg/Kg		101	75 - 125	1	30
Mo	25.0	25.1		mg/Kg		100	75 - 125	0	30
Selenium	7.50	8.06		mg/Kg		108	75 - 125	3	30
Thallium	20.0	20.1		mg/Kg		101	75 - 125	2	30

Lab Sample ID: 140-15490-1 DU
Matrix: Solid
Analysis Batch: 31604

Client Sample ID: AP-2019-1 (30-31)
Prep Type: Step 1
Prep Batch: 31252

Analyte	Sample Result	Sample Qualifier	DU DU		Unit	D	RPD	Limit
			Result	Qualifier				
Aluminum	ND		ND		mg/Kg	☼	NC	30
Antimony	ND		ND		mg/Kg	☼	NC	30
Arsenic	ND		ND		mg/Kg	☼	NC	30
Barium	0.88	J	0.934	J	mg/Kg	☼	5	30
Beryllium	ND		ND		mg/Kg	☼	NC	30
Cobalt	0.54	J	0.626	J	mg/Kg	☼	15	30
Iron	ND		ND		mg/Kg	☼	NC	30
Li	ND		ND		mg/Kg	☼	NC	30
Manganese	3.1	J	3.66	J	mg/Kg	☼	16	30
Mo	ND		ND		mg/Kg	☼	NC	30
Selenium	ND		ND		mg/Kg	☼	NC	30
Thallium	ND		ND		mg/Kg	☼	NC	30

Lab Sample ID: MB 140-31253/13-B ^3
Matrix: Solid
Analysis Batch: 31604

Client Sample ID: Method Blank
Prep Type: Step 2
Prep Batch: 31256

Analyte	MB MB		RL	MDL	Unit	D	Prepared	Analyzed	Dil Fac
	Result	Qualifier							
Aluminum	ND		30	4.8	mg/Kg		06/30/19 08:00	07/11/19 14:06	3
Antimony	ND		9.0	0.84	mg/Kg		06/30/19 08:00	07/11/19 14:06	3
Arsenic	ND		1.5	0.39	mg/Kg		06/30/19 08:00	07/11/19 14:06	3
Barium	ND		7.5	0.36	mg/Kg		06/30/19 08:00	07/11/19 14:06	3
Beryllium	ND		0.75	0.048	mg/Kg		06/30/19 08:00	07/11/19 14:06	3
Cobalt	ND		7.5	0.19	mg/Kg		06/30/19 08:00	07/11/19 14:06	3
Iron	ND		15	8.7	mg/Kg		06/30/19 08:00	07/11/19 14:06	3
Li	ND		7.5	0.45	mg/Kg		06/30/19 08:00	07/11/19 14:06	3
Manganese	ND		2.3	0.84	mg/Kg		06/30/19 08:00	07/11/19 14:06	3
Mo	ND		6.0	0.25	mg/Kg		06/30/19 08:00	07/11/19 14:06	3
Selenium	0.587	J	1.5	0.51	mg/Kg		06/30/19 08:00	07/11/19 14:06	3
Thallium	ND		5.3	0.63	mg/Kg		06/30/19 08:00	07/11/19 14:06	3

Eurofins TestAmerica, Knoxville

QC Sample Results

Client: Golder Associates Inc.
 Project/Site: Martin Lake Ash Ponds - SEP + Totals

Job ID: 140-15490-1

Method: 6010B SEP - SEP Metals (ICP) (Continued)

Lab Sample ID: LCS 140-31253/14-B ^5
Matrix: Solid
Analysis Batch: 31604

Client Sample ID: Lab Control Sample
Prep Type: Step 2
Prep Batch: 31256

Analyte	Spike Added	LCS Result	LCS Qualifier	Unit	D	%Rec	%Rec. Limits
Aluminum	100	ND	*	mg/Kg		1	75 - 125
Antimony	25.0	21.1		mg/Kg		84	75 - 125
Arsenic	5.00	3.95		mg/Kg		79	75 - 125
Barium	5.00	2.28	J *	mg/Kg		46	75 - 125
Beryllium	2.50	1.35	*	mg/Kg		54	75 - 125
Cobalt	5.00	4.62	J	mg/Kg		92	75 - 125
Iron	50.0	ND	*	mg/Kg		2	75 - 125
Li	5.00	4.14	J	mg/Kg		83	75 - 125
Manganese	5.00	4.79		mg/Kg		96	75 - 125
Mo	25.0	20.7		mg/Kg		83	75 - 125
Selenium	7.50	7.34		mg/Kg		98	75 - 125
Thallium	20.0	18.4		mg/Kg		92	75 - 125

Lab Sample ID: LCSD 140-31253/15-B ^5
Matrix: Solid
Analysis Batch: 31604

Client Sample ID: Lab Control Sample Dup
Prep Type: Step 2
Prep Batch: 31256

Analyte	Spike Added	LCSD Result	LCSD Qualifier	Unit	D	%Rec	%Rec. Limits	RPD	RPD Limit
Aluminum	100	ND	*	mg/Kg		-0.3	75 - 125	289	30
Antimony	25.0	21.4		mg/Kg		86	75 - 125	1	30
Arsenic	5.00	4.00		mg/Kg		80	75 - 125	1	30
Barium	5.00	2.28	J *	mg/Kg		46	75 - 125	0	30
Beryllium	2.50	1.32	*	mg/Kg		53	75 - 125	2	30
Cobalt	5.00	4.62	J	mg/Kg		92	75 - 125	0	30
Iron	50.0	ND	*	mg/Kg		3	75 - 125	28	30
Li	5.00	4.15	J	mg/Kg		83	75 - 125	0	30
Manganese	5.00	4.76		mg/Kg		95	75 - 125	1	30
Mo	25.0	20.9		mg/Kg		84	75 - 125	1	30
Selenium	7.50	6.68		mg/Kg		89	75 - 125	10	30
Thallium	20.0	18.6		mg/Kg		93	75 - 125	1	30

Lab Sample ID: 140-15490-1 DU
Matrix: Solid
Analysis Batch: 31604

Client Sample ID: AP-2019-1 (30-31)
Prep Type: Step 2
Prep Batch: 31256

Analyte	Sample Result	Sample Qualifier	DU Result	DU Qualifier	Unit	D	RPD	RPD Limit
Aluminum	9.7	J *	11.8	J *	mg/Kg	☼	19	30
Antimony	ND		ND		mg/Kg	☼	NC	30
Arsenic	ND		ND		mg/Kg	☼	NC	30
Barium	0.76	J *	0.792	J *	mg/Kg	☼	4	30
Beryllium	ND	*	ND	*	mg/Kg	☼	NC	30
Cobalt	ND		ND		mg/Kg	☼	NC	30
Iron	ND	*	ND	*	mg/Kg	☼	NC	30
Li	ND		ND		mg/Kg	☼	NC	30
Manganese	ND		ND		mg/Kg	☼	NC	30
Mo	ND		ND		mg/Kg	☼	NC	30
Selenium	0.76	J B	0.794	J	mg/Kg	☼	4	30
Thallium	ND		ND		mg/Kg	☼	NC	30

Eurofins TestAmerica, Knoxville

QC Sample Results

Client: Golder Associates Inc.
 Project/Site: Martin Lake Ash Ponds - SEP + Totals

Job ID: 140-15490-1

Method: 6010B SEP - SEP Metals (ICP) (Continued)

Lab Sample ID: MB 140-31257/13-B
Matrix: Solid
Analysis Batch: 31604

Client Sample ID: Method Blank
Prep Type: Step 3
Prep Batch: 31338

Analyte	MB Result	MB Qualifier	RL	MDL	Unit	D	Prepared	Analyzed	Dil Fac
Aluminum	ND		10	2.1	mg/Kg		07/02/19 08:00	07/11/19 15:50	1
Antimony	ND		3.0	0.28	mg/Kg		07/02/19 08:00	07/11/19 15:50	1
Arsenic	ND		0.50	0.13	mg/Kg		07/02/19 08:00	07/11/19 15:50	1
Barium	0.151	J	2.5	0.12	mg/Kg		07/02/19 08:00	07/11/19 15:50	1
Beryllium	ND		0.25	0.015	mg/Kg		07/02/19 08:00	07/11/19 15:50	1
Cobalt	ND		2.5	0.045	mg/Kg		07/02/19 08:00	07/11/19 15:50	1
Iron	ND		5.0	2.9	mg/Kg		07/02/19 08:00	07/11/19 15:50	1
Li	ND		2.5	0.15	mg/Kg		07/02/19 08:00	07/11/19 15:50	1
Manganese	0.0515	J	0.75	0.027	mg/Kg		07/02/19 08:00	07/11/19 15:50	1
Mo	ND		2.0	0.082	mg/Kg		07/02/19 08:00	07/11/19 15:50	1
Selenium	0.197	J	0.50	0.17	mg/Kg		07/02/19 08:00	07/11/19 15:50	1
Thallium	ND		1.8	0.21	mg/Kg		07/02/19 08:00	07/11/19 15:50	1

Lab Sample ID: LCS 140-31257/14-B
Matrix: Solid
Analysis Batch: 31604

Client Sample ID: Lab Control Sample
Prep Type: Step 3
Prep Batch: 31338

Analyte	Spike Added	LCS Result	LCS Qualifier	Unit	D	%Rec	%Rec. Limits
Aluminum	100	95.8		mg/Kg		96	75 - 125
Antimony	25.0	24.3		mg/Kg		97	75 - 125
Arsenic	5.00	4.90		mg/Kg		98	75 - 125
Barium	5.00	4.34		mg/Kg		87	75 - 125
Beryllium	2.50	2.56		mg/Kg		102	75 - 125
Cobalt	5.00	4.90		mg/Kg		98	75 - 125
Iron	50.0	54.0		mg/Kg		108	75 - 125
Li	5.00	4.87		mg/Kg		97	75 - 125
Manganese	5.00	5.03		mg/Kg		101	75 - 125
Mo	25.0	24.8		mg/Kg		99	75 - 125
Selenium	7.50	7.37		mg/Kg		98	75 - 125
Thallium	20.0	20.2		mg/Kg		101	75 - 125

Lab Sample ID: LCSD 140-31257/15-B
Matrix: Solid
Analysis Batch: 31604

Client Sample ID: Lab Control Sample Dup
Prep Type: Step 3
Prep Batch: 31338

Analyte	Spike Added	LCSD Result	LCSD Qualifier	Unit	D	%Rec	%Rec. Limits	RPD	RPD Limit
Aluminum	100	98.1		mg/Kg		98	75 - 125	2	30
Antimony	25.0	24.6		mg/Kg		98	75 - 125	1	30
Arsenic	5.00	5.06		mg/Kg		101	75 - 125	3	30
Barium	5.00	4.49		mg/Kg		90	75 - 125	3	30
Beryllium	2.50	2.61		mg/Kg		104	75 - 125	2	30
Cobalt	5.00	4.97		mg/Kg		99	75 - 125	1	30
Iron	50.0	51.0		mg/Kg		102	75 - 125	6	30
Li	5.00	4.95		mg/Kg		99	75 - 125	2	30
Manganese	5.00	5.06		mg/Kg		101	75 - 125	1	30
Mo	25.0	24.9		mg/Kg		100	75 - 125	0	30
Selenium	7.50	7.63		mg/Kg		102	75 - 125	3	30
Thallium	20.0	20.5		mg/Kg		103	75 - 125	2	30

Eurofins TestAmerica, Knoxville

QC Sample Results

Client: Golder Associates Inc.
 Project/Site: Martin Lake Ash Ponds - SEP + Totals

Job ID: 140-15490-1

Method: 6010B SEP - SEP Metals (ICP) (Continued)

Lab Sample ID: 140-15490-1 DU
Matrix: Solid
Analysis Batch: 31604

Client Sample ID: AP-2019-1 (30-31)
Prep Type: Step 3
Prep Batch: 31338

Analyte	Sample	Sample	DU	DU	Unit	D	RPD	Limit
	Result	Qualifier	Result	Qualifier				
Aluminum	88		90.2		mg/Kg	☼	3	30
Antimony	ND		ND		mg/Kg	☼	NC	30
Arsenic	1.8		1.75		mg/Kg	☼	5	30
Barium	4.3	B	4.58		mg/Kg	☼	7	30
Beryllium	0.067	J	0.0665	J	mg/Kg	☼	1	30
Cobalt	0.34	J	0.478	J F5	mg/Kg	☼	32	30
Iron	580		553		mg/Kg	☼	4	30
Li	ND		ND		mg/Kg	☼	NC	30
Manganese	2.4	B	2.99		mg/Kg	☼	20	30
Mo	ND		ND		mg/Kg	☼	NC	30
Selenium	0.22	J B	0.249	J	mg/Kg	☼	14	30
Thallium	ND		ND		mg/Kg	☼	NC	30

Lab Sample ID: MB 140-31341/13-B
Matrix: Solid
Analysis Batch: 31604

Client Sample ID: Method Blank
Prep Type: Step 4
Prep Batch: 31360

Analyte	MB	MB	RL	MDL	Unit	D	Prepared	Analyzed	Dil Fac
	Result	Qualifier							
Aluminum	ND		10	1.6	mg/Kg		07/03/19 08:00	07/11/19 17:24	1
Antimony	ND		3.0	0.45	mg/Kg		07/03/19 08:00	07/11/19 17:24	1
Arsenic	0.260	J	0.50	0.22	mg/Kg		07/03/19 08:00	07/11/19 17:24	1
Barium	ND		2.5	0.12	mg/Kg		07/03/19 08:00	07/11/19 17:24	1
Beryllium	ND		0.25	0.016	mg/Kg		07/03/19 08:00	07/11/19 17:24	1
Cobalt	ND		2.5	0.053	mg/Kg		07/03/19 08:00	07/11/19 17:24	1
Iron	ND		5.0	2.9	mg/Kg		07/03/19 08:00	07/11/19 17:24	1
Li	ND		2.5	0.15	mg/Kg		07/03/19 08:00	07/11/19 17:24	1
Manganese	ND		0.75	0.13	mg/Kg		07/03/19 08:00	07/11/19 17:24	1
Mo	ND		2.0	0.082	mg/Kg		07/03/19 08:00	07/11/19 17:24	1
Selenium	0.561		0.50	0.47	mg/Kg		07/03/19 08:00	07/11/19 17:24	1
Thallium	ND		1.8	0.29	mg/Kg		07/03/19 08:00	07/11/19 17:24	1

Lab Sample ID: LCS 140-31341/14-B
Matrix: Solid
Analysis Batch: 31604

Client Sample ID: Lab Control Sample
Prep Type: Step 4
Prep Batch: 31360

Analyte	Spike Added	LCS	LCS	Unit	D	%Rec	%Rec. Limits
		Result	Qualifier				
Aluminum	100	98.4		mg/Kg		98	75 - 125
Antimony	25.0	25.6		mg/Kg		102	75 - 125
Arsenic	5.00	5.48		mg/Kg		110	75 - 125
Barium	5.00	4.90		mg/Kg		98	75 - 125
Beryllium	2.50	2.66		mg/Kg		106	75 - 125
Cobalt	5.00	4.92		mg/Kg		98	75 - 125
Iron	50.0	50.0		mg/Kg		100	75 - 125
Li	5.00	4.92		mg/Kg		98	75 - 125
Manganese	5.00	4.98		mg/Kg		100	75 - 125
Mo	25.0	25.7		mg/Kg		103	75 - 125
Selenium	7.50	0.762	*	mg/Kg		10	75 - 125
Thallium	20.0	17.2		mg/Kg		86	75 - 125

QC Sample Results

Client: Golder Associates Inc.
 Project/Site: Martin Lake Ash Ponds - SEP + Totals

Job ID: 140-15490-1

Method: 6010B SEP - SEP Metals (ICP) (Continued)

Lab Sample ID: LCSD 140-31341/15-B
Matrix: Solid
Analysis Batch: 31604

Client Sample ID: Lab Control Sample Dup
Prep Type: Step 4
Prep Batch: 31360

Analyte	Spike Added	LCSD Result	LCSD Qualifier	Unit	D	%Rec	%Rec. Limits	RPD	RPD Limit
Aluminum	100	101		mg/Kg		101	75 - 125	3	30
Antimony	25.0	25.9		mg/Kg		103	75 - 125	1	30
Arsenic	5.00	5.55		mg/Kg		111	75 - 125	1	30
Barium	5.00	5.04		mg/Kg		101	75 - 125	3	30
Beryllium	2.50	2.74		mg/Kg		109	75 - 125	3	30
Cobalt	5.00	5.07		mg/Kg		101	75 - 125	3	30
Iron	50.0	51.5		mg/Kg		103	75 - 125	3	30
Li	5.00	5.09		mg/Kg		102	75 - 125	3	30
Manganese	5.00	5.13		mg/Kg		103	75 - 125	3	30
Mo	25.0	25.9		mg/Kg		104	75 - 125	1	30
Selenium	7.50	0.631	*	mg/Kg		8	75 - 125	19	30
Thallium	20.0	17.9		mg/Kg		89	75 - 125	4	30

Lab Sample ID: 140-15490-1 DU
Matrix: Solid
Analysis Batch: 31604

Client Sample ID: AP-2019-1 (30-31)
Prep Type: Step 4
Prep Batch: 31360

Analyte	Sample Result	Sample Qualifier	DU Result	DU Qualifier	Unit	D	RPD	Limit
Aluminum	1700		1740		mg/Kg	☼	0.1	30
Antimony	ND		ND		mg/Kg	☼	NC	30
Arsenic	2.8	B	2.56		mg/Kg	☼	10	30
Barium	16		18.8		mg/Kg	☼	15	30
Beryllium	0.13	J	0.135	J	mg/Kg	☼	1	30
Cobalt	1.5	J	1.59	J	mg/Kg	☼	8	30
Iron	3900		3860		mg/Kg	☼	2	30
Li	3.0	J	3.10	J	mg/Kg	☼	2	30
Manganese	18		18.2		mg/Kg	☼	0.4	30
Mo	ND		ND		mg/Kg	☼	NC	30
Selenium	ND	*	0.624	J *	mg/Kg	☼	NC	30
Thallium	ND		ND		mg/Kg	☼	NC	30

Lab Sample ID: MB 140-31436/13-B ^5
Matrix: Solid
Analysis Batch: 31651

Client Sample ID: Method Blank
Prep Type: Step 5
Prep Batch: 31500

Analyte	MB Result	MB Qualifier	RL	MDL	Unit	D	Prepared	Analyzed	Dil Fac
Aluminum	ND		150	24	mg/Kg		07/10/19 08:00	07/12/19 11:39	5
Antimony	ND		45	4.2	mg/Kg		07/10/19 08:00	07/12/19 11:39	5
Arsenic	ND		7.5	1.9	mg/Kg		07/10/19 08:00	07/12/19 11:39	5
Barium	ND		38	1.8	mg/Kg		07/10/19 08:00	07/12/19 11:39	5
Beryllium	ND		3.8	0.32	mg/Kg		07/10/19 08:00	07/12/19 11:39	5
Cobalt	ND		38	0.60	mg/Kg		07/10/19 08:00	07/12/19 11:39	5
Iron	ND		75	44	mg/Kg		07/10/19 08:00	07/12/19 11:39	5
Li	ND		38	2.2	mg/Kg		07/10/19 08:00	07/12/19 11:39	5
Manganese	ND		11	1.9	mg/Kg		07/10/19 08:00	07/12/19 11:39	5
Mo	ND		30	1.3	mg/Kg		07/10/19 08:00	07/12/19 11:39	5
Selenium	ND		7.5	2.6	mg/Kg		07/10/19 08:00	07/12/19 11:39	5
Thallium	ND		26	3.5	mg/Kg		07/10/19 08:00	07/12/19 11:39	5

Eurofins TestAmerica, Knoxville

QC Sample Results

Client: Golder Associates Inc.
 Project/Site: Martin Lake Ash Ponds - SEP + Totals

Job ID: 140-15490-1

Method: 6010B SEP - SEP Metals (ICP) (Continued)

Lab Sample ID: LCS 140-31436/14-B ^5
Matrix: Solid
Analysis Batch: 31651

Client Sample ID: Lab Control Sample
Prep Type: Step 5
Prep Batch: 31500

Analyte	Spike Added	LCS Result	LCS Qualifier	Unit	D	%Rec	%Rec. Limits
Aluminum	300	ND	*	mg/Kg		6	75 - 125
Antimony	75.0	81.2		mg/Kg		108	75 - 125
Arsenic	15.0	12.3		mg/Kg		82	75 - 125
Barium	15.0	7.80	J *	mg/Kg		52	75 - 125
Beryllium	7.50	4.23	*	mg/Kg		56	75 - 125
Cobalt	15.0	4.86	J *	mg/Kg		32	75 - 125
Iron	150	ND	*	mg/Kg		2	75 - 125
Li	15.0	16.4	J	mg/Kg		109	75 - 125
Manganese	15.0	4.82	J *	mg/Kg		32	75 - 125
Mo	75.0	64.7		mg/Kg		86	75 - 125
Selenium	22.5	24.8		mg/Kg		110	75 - 125
Thallium	60.0	ND	*	mg/Kg		2	75 - 125

Lab Sample ID: LCSD 140-31436/15-B ^5
Matrix: Solid
Analysis Batch: 31651

Client Sample ID: Lab Control Sample Dup
Prep Type: Step 5
Prep Batch: 31500

Analyte	Spike Added	LCSD Result	LCSD Qualifier	Unit	D	%Rec	%Rec. Limits	RPD	RPD Limit
Aluminum	300	ND	*	mg/Kg		7	75 - 125	14	30
Antimony	75.0	82.5		mg/Kg		110	75 - 125	2	30
Arsenic	15.0	12.5		mg/Kg		83	75 - 125	2	30
Barium	15.0	7.73	J *	mg/Kg		52	75 - 125	1	30
Beryllium	7.50	4.34	*	mg/Kg		58	75 - 125	2	30
Cobalt	15.0	5.05	J *	mg/Kg		34	75 - 125	4	30
Iron	150	ND	*	mg/Kg		3	75 - 125	55	30
Li	15.0	16.1	J	mg/Kg		107	75 - 125	2	30
Manganese	15.0	4.97	J *	mg/Kg		33	75 - 125	3	30
Mo	75.0	64.0		mg/Kg		85	75 - 125	1	30
Selenium	22.5	26.2		mg/Kg		116	75 - 125	6	30
Thallium	60.0	ND	*	mg/Kg		0.9	75 - 125	60	30

Lab Sample ID: 140-15490-1 DU
Matrix: Solid
Analysis Batch: 31651

Client Sample ID: AP-2019-1 (30-31)
Prep Type: Step 5
Prep Batch: 31500

Analyte	Sample Result	Sample Qualifier	DU Result	DU Qualifier	Unit	D	RPD	RPD Limit
Aluminum	62	J *	54.9	J *	mg/Kg	☼	12	30
Antimony	ND		ND		mg/Kg	☼	NC	30
Arsenic	ND		ND		mg/Kg	☼	NC	30
Barium	7.0	J *	8.10	J *	mg/Kg	☼	15	30
Beryllium	ND	*	ND	*	mg/Kg	☼	NC	30
Cobalt	ND	*	ND	*	mg/Kg	☼	NC	30
Iron	ND	*	ND	*	mg/Kg	☼	NC	30
Li	ND		ND		mg/Kg	☼	NC	30
Manganese	ND	*	ND	*	mg/Kg	☼	NC	30
Mo	ND		ND		mg/Kg	☼	NC	30
Selenium	ND		ND		mg/Kg	☼	NC	30
Thallium	ND	*	ND	*	mg/Kg	☼	NC	30

Eurofins TestAmerica, Knoxville

QC Sample Results

Client: Golder Associates Inc.
 Project/Site: Martin Lake Ash Ponds - SEP + Totals

Job ID: 140-15490-1

Method: 6010B SEP - SEP Metals (ICP) (Continued)

Lab Sample ID: MB 140-31502/13-A
Matrix: Solid
Analysis Batch: 31651

Client Sample ID: Method Blank
Prep Type: Step 6
Prep Batch: 31502

Analyte	MB	MB	RL	MDL	Unit	D	Prepared	Analyzed	Dil Fac
	Result	Qualifier							
Aluminum	ND		10	1.6	mg/Kg		07/10/19 08:00	07/12/19 13:14	1
Antimony	ND		3.0	0.28	mg/Kg		07/10/19 08:00	07/12/19 13:14	1
Arsenic	ND		0.50	0.15	mg/Kg		07/10/19 08:00	07/12/19 13:14	1
Barium	ND		2.5	0.12	mg/Kg		07/10/19 08:00	07/12/19 13:14	1
Beryllium	ND		0.25	0.012	mg/Kg		07/10/19 08:00	07/12/19 13:14	1
Cobalt	ND		2.5	0.046	mg/Kg		07/10/19 08:00	07/12/19 13:14	1
Iron	ND		5.0	2.9	mg/Kg		07/10/19 08:00	07/12/19 13:14	1
Li	ND		2.5	0.15	mg/Kg		07/10/19 08:00	07/12/19 13:14	1
Manganese	ND		0.75	0.25	mg/Kg		07/10/19 08:00	07/12/19 13:14	1
Mo	ND		2.0	0.099	mg/Kg		07/10/19 08:00	07/12/19 13:14	1
Selenium	ND		0.50	0.17	mg/Kg		07/10/19 08:00	07/12/19 13:14	1
Thallium	ND		1.8	0.21	mg/Kg		07/10/19 08:00	07/12/19 13:14	1

Lab Sample ID: LCS 140-31502/14-A
Matrix: Solid
Analysis Batch: 31651

Client Sample ID: Lab Control Sample
Prep Type: Step 6
Prep Batch: 31502

Analyte	Spike Added	LCS	LCS	Unit	D	%Rec	%Rec. Limits
		Result	Qualifier				
Aluminum	100	95.4		mg/Kg		95	75 - 125
Antimony	25.0	24.8		mg/Kg		99	75 - 125
Arsenic	5.00	4.94		mg/Kg		99	75 - 125
Barium	5.00	4.58		mg/Kg		92	75 - 125
Beryllium	2.50	2.57		mg/Kg		103	75 - 125
Cobalt	5.00	4.78		mg/Kg		96	75 - 125
Iron	50.0	47.4		mg/Kg		95	75 - 125
Li	5.00	4.71		mg/Kg		94	75 - 125
Manganese	5.00	4.83		mg/Kg		97	75 - 125
Mo	25.0	24.7		mg/Kg		99	75 - 125
Selenium	7.50	7.32		mg/Kg		98	75 - 125
Thallium	20.0	19.8		mg/Kg		99	75 - 125

Lab Sample ID: LCSD 140-31502/15-A
Matrix: Solid
Analysis Batch: 31651

Client Sample ID: Lab Control Sample Dup
Prep Type: Step 6
Prep Batch: 31502

Analyte	Spike Added	LCSD	LCSD	Unit	D	%Rec	%Rec. Limits	RPD	
		Result	Qualifier					RPD	Limit
Aluminum	100	98.8		mg/Kg		99	75 - 125	4	30
Antimony	25.0	25.5		mg/Kg		102	75 - 125	3	30
Arsenic	5.00	5.16		mg/Kg		103	75 - 125	4	30
Barium	5.00	4.77		mg/Kg		95	75 - 125	4	30
Beryllium	2.50	2.67		mg/Kg		107	75 - 125	4	30
Cobalt	5.00	4.97		mg/Kg		99	75 - 125	4	30
Iron	50.0	49.5		mg/Kg		99	75 - 125	4	30
Li	5.00	4.90		mg/Kg		98	75 - 125	4	30
Manganese	5.00	5.02		mg/Kg		100	75 - 125	4	30
Mo	25.0	25.2		mg/Kg		101	75 - 125	2	30
Selenium	7.50	7.50		mg/Kg		100	75 - 125	2	30
Thallium	20.0	20.6		mg/Kg		103	75 - 125	4	30

Eurofins TestAmerica, Knoxville

QC Sample Results

Client: Golder Associates Inc.
 Project/Site: Martin Lake Ash Ponds - SEP + Totals

Job ID: 140-15490-1

Method: 6010B SEP - SEP Metals (ICP) (Continued)

Lab Sample ID: 140-15490-1 DU
Matrix: Solid
Analysis Batch: 31651

Client Sample ID: AP-2019-1 (30-31)
Prep Type: Step 6
Prep Batch: 31502

Analyte	Sample	Sample	DU	DU	Unit	D	RPD	Limit
	Result	Qualifier	Result	Qualifier				
Aluminum	2300		2370		mg/Kg	☼	2	30
Antimony	ND		ND		mg/Kg	☼	NC	30
Arsenic	0.94		0.869		mg/Kg	☼	8	30
Barium	18		18.6		mg/Kg	☼	6	30
Beryllium	0.067	J	0.0691	J	mg/Kg	☼	3	30
Cobalt	0.90	J	0.940	J	mg/Kg	☼	5	30
Iron	2500		2510		mg/Kg	☼	0.4	30
Li	2.1	J	2.17	J	mg/Kg	☼	3	30
Manganese	16		16.1		mg/Kg	☼	0.6	30
Mo	ND		ND		mg/Kg	☼	NC	30
Selenium	ND		ND		mg/Kg	☼	NC	30
Thallium	ND		ND		mg/Kg	☼	NC	30

Lab Sample ID: MB 140-31615/13-A
Matrix: Solid
Analysis Batch: 31713

Client Sample ID: Method Blank
Prep Type: Step 7
Prep Batch: 31615

Analyte	MB	MB	RL	MDL	Unit	D	Prepared	Analyzed	Dil Fac
	Result	Qualifier							
Aluminum	ND		10	1.6	mg/Kg		07/12/19 09:08	07/15/19 10:58	1
Antimony	ND		3.0	0.14	mg/Kg		07/12/19 09:08	07/15/19 10:58	1
Arsenic	ND		0.50	0.13	mg/Kg		07/12/19 09:08	07/15/19 10:58	1
Barium	ND		2.5	0.12	mg/Kg		07/12/19 09:08	07/15/19 10:58	1
Beryllium	ND		0.25	0.0075	mg/Kg		07/12/19 09:08	07/15/19 10:58	1
Cobalt	ND		2.5	0.15	mg/Kg		07/12/19 09:08	07/15/19 10:58	1
Iron	ND		5.0	4.1	mg/Kg		07/12/19 09:08	07/15/19 10:58	1
Li	ND		2.5	0.15	mg/Kg		07/12/19 09:08	07/15/19 10:58	1
Manganese	ND		0.75	0.052	mg/Kg		07/12/19 09:08	07/15/19 10:58	1
Mo	ND		2.0	0.082	mg/Kg		07/12/19 09:08	07/15/19 10:58	1
Selenium	ND		0.50	0.17	mg/Kg		07/12/19 09:08	07/15/19 10:58	1
Thallium	ND		1.8	0.18	mg/Kg		07/12/19 09:08	07/15/19 10:58	1

Lab Sample ID: LCS 140-31615/14-A
Matrix: Solid
Analysis Batch: 31713

Client Sample ID: Lab Control Sample
Prep Type: Step 7
Prep Batch: 31615

Analyte	Spike Added	LCS	LCS	Unit	D	%Rec	%Rec. Limits
		Result	Qualifier				
Aluminum	100	96.8		mg/Kg		97	75 - 125
Antimony	25.0	25.7		mg/Kg		103	75 - 125
Arsenic	5.00	5.23		mg/Kg		105	75 - 125
Barium	5.00	4.99		mg/Kg		100	75 - 125
Beryllium	2.50	2.52		mg/Kg		101	75 - 125
Cobalt	5.00	5.20		mg/Kg		104	75 - 125
Iron	50.0	51.7		mg/Kg		103	75 - 125
Li	5.00	5.15		mg/Kg		103	75 - 125
Manganese	5.00	5.21		mg/Kg		104	75 - 125
Mo	25.0	26.5		mg/Kg		106	75 - 125
Selenium	7.50	7.52		mg/Kg		100	75 - 125
Thallium	20.0	21.2		mg/Kg		106	75 - 125

QC Sample Results

Client: Golder Associates Inc.
 Project/Site: Martin Lake Ash Ponds - SEP + Totals

Job ID: 140-15490-1

Method: 6010B SEP - SEP Metals (ICP) (Continued)

Lab Sample ID: LCSD 140-31615/15-A
Matrix: Solid
Analysis Batch: 31713

Client Sample ID: Lab Control Sample Dup
Prep Type: Step 7
Prep Batch: 31615

Analyte	Spike Added	LCSD Result	LCSD Qualifier	Unit	D	%Rec	%Rec. Limits	RPD	
								RPD	Limit
Aluminum	100	98.0		mg/Kg		98	75 - 125	1	30
Antimony	25.0	25.8		mg/Kg		103	75 - 125	0	30
Arsenic	5.00	5.30		mg/Kg		106	75 - 125	1	30
Barium	5.00	4.99		mg/Kg		100	75 - 125	0	30
Beryllium	2.50	2.50		mg/Kg		100	75 - 125	1	30
Cobalt	5.00	5.21		mg/Kg		104	75 - 125	0	30
Iron	50.0	51.5		mg/Kg		103	75 - 125	0	30
Li	5.00	5.18		mg/Kg		104	75 - 125	1	30
Manganese	5.00	5.21		mg/Kg		104	75 - 125	0	30
Mo	25.0	26.7		mg/Kg		107	75 - 125	1	30
Selenium	7.50	7.55		mg/Kg		101	75 - 125	0	30
Thallium	20.0	21.3		mg/Kg		107	75 - 125	1	30

Lab Sample ID: 140-15490-1 DU
Matrix: Solid
Analysis Batch: 31713

Client Sample ID: AP-2019-1 (30-31)
Prep Type: Step 7
Prep Batch: 31615

Analyte	Sample Result	Sample Qualifier	DU		Unit	D	RPD	Limit
			Result	Qualifier				
Antimony	ND		ND		mg/Kg	☼	NC	30
Arsenic	1.2		1.16		mg/Kg	☼	6	30
Beryllium	0.56		0.602		mg/Kg	☼	7	30
Iron	5200		5740		mg/Kg	☼	11	30
Li	9.6		10.9		mg/Kg	☼	13	30
Manganese	26		29.0		mg/Kg	☼	9	30
Mo	0.19 J		0.209 J		mg/Kg	☼	10	30
Selenium	ND		ND		mg/Kg	☼	NC	30

Lab Sample ID: 140-15490-1 DU
Matrix: Solid
Analysis Batch: 31713

Client Sample ID: AP-2019-1 (30-31)
Prep Type: Step 7
Prep Batch: 31615

Analyte	Sample Result	Sample Qualifier	DU		Unit	D	RPD	Limit
			Result	Qualifier				
Aluminum	29000		35900		mg/Kg	☼	23	30
Barium	390		447		mg/Kg	☼	14	30

Lab Sample ID: 140-15490-1 DU
Matrix: Solid
Analysis Batch: 31713

Client Sample ID: AP-2019-1 (30-31)
Prep Type: Step 7
Prep Batch: 31615

Analyte	Sample Result	Sample Qualifier	DU		Unit	D	RPD	Limit
			Result	Qualifier				
Cobalt	0.79 J		0.899 J		mg/Kg	☼	12	30
Thallium	0.48 J		ND		mg/Kg	☼	NC	30

QC Sample Results

Client: Golder Associates Inc.
 Project/Site: Martin Lake Ash Ponds - SEP + Totals

Job ID: 140-15490-1

Method: 7470A - SEP Mercury (CVAA) - Total

Lab Sample ID: MB 140-30683/13-B
Matrix: Solid
Analysis Batch: 30868

Client Sample ID: Method Blank
Prep Type: Total/NA
Prep Batch: 30683

Analyte	MB Result	MB Qualifier	RL	MDL	Unit	D	Prepared	Analyzed	Dil Fac
Hg	ND		0.10	0.040	mg/Kg		06/11/19 08:00	06/16/19 13:56	1

Lab Sample ID: LCS 140-30683/14-B
Matrix: Solid
Analysis Batch: 30868

Client Sample ID: Lab Control Sample
Prep Type: Total/NA
Prep Batch: 30683

Analyte	Spike Added	LCS Result	LCS Qualifier	Unit	D	%Rec	%Rec. Limits
Hg	2.50	2.70		mg/Kg		108	75 - 125

Lab Sample ID: LCSD 140-30683/15-B
Matrix: Solid
Analysis Batch: 30868

Client Sample ID: Lab Control Sample Dup
Prep Type: Total/NA
Prep Batch: 30683

Analyte	Spike Added	LCSD Result	LCSD Qualifier	Unit	D	%Rec	%Rec. Limits	RPD	RPD Limit
Hg	2.50	2.71		mg/Kg		108	75 - 125	0	30

Lab Sample ID: 140-15490-1 DU
Matrix: Solid
Analysis Batch: 30868

Client Sample ID: AP-2019-1 (30-31)
Prep Type: Total/NA
Prep Batch: 30683

Analyte	Sample Result	Sample Qualifier	DU Result	DU Qualifier	Unit	D	RPD	RPD Limit
Hg	0.081	J	0.102	J	mg/Kg	✱	23	30

LUMINANT

QC Association Summary

Client: Golder Associates Inc.
Project/Site: Martin Lake Ash Ponds - SEP + Totals

Job ID: 140-15490-1

Metals

Prep Batch: 30683

Lab Sample ID	Client Sample ID	Prep Type	Matrix	Method	Prep Batch
140-15490-1	AP-2019-1 (30-31)	Total/NA	Solid	Total	
140-15490-2	AP-2019-2 (35-36)	Total/NA	Solid	Total	
140-15490-3	AP-2019-3 (18-19)	Total/NA	Solid	Total	
MB 140-30683/13-A	Method Blank	Total/NA	Solid	Total	
MB 140-30683/13-B	Method Blank	Total/NA	Solid	Total	
LCS 140-30683/14-A	Lab Control Sample	Total/NA	Solid	Total	
LCS 140-30683/14-B	Lab Control Sample	Total/NA	Solid	Total	
LCSD 140-30683/15-A	Lab Control Sample Dup	Total/NA	Solid	Total	
LCSD 140-30683/15-B	Lab Control Sample Dup	Total/NA	Solid	Total	
140-15490-1 DU	AP-2019-1 (30-31)	Total/NA	Solid	Total	

Prep Batch: 30859

Lab Sample ID	Client Sample ID	Prep Type	Matrix	Method	Prep Batch
140-15490-1	AP-2019-1 (30-31)	Total/NA	Solid	7470A	30683
140-15490-2	AP-2019-2 (35-36)	Total/NA	Solid	7470A	30683
140-15490-3	AP-2019-3 (18-19)	Total/NA	Solid	7470A	30683
MB 140-30683/13-B	Method Blank	Total/NA	Solid	7470A	30683
LCS 140-30683/14-B	Lab Control Sample	Total/NA	Solid	7470A	30683
LCSD 140-30683/15-B	Lab Control Sample Dup	Total/NA	Solid	7470A	30683
140-15490-1 DU	AP-2019-1 (30-31)	Total/NA	Solid	7470A	30683

Analysis Batch: 30868

Lab Sample ID	Client Sample ID	Prep Type	Matrix	Method	Prep Batch
140-15490-1	AP-2019-1 (30-31)	Total/NA	Solid	7470A	30859
140-15490-2	AP-2019-2 (35-36)	Total/NA	Solid	7470A	30859
140-15490-3	AP-2019-3 (18-19)	Total/NA	Solid	7470A	30859
MB 140-30683/13-B	Method Blank	Total/NA	Solid	7470A	30859
LCS 140-30683/14-B	Lab Control Sample	Total/NA	Solid	7470A	30859
LCSD 140-30683/15-B	Lab Control Sample Dup	Total/NA	Solid	7470A	30859
140-15490-1 DU	AP-2019-1 (30-31)	Total/NA	Solid	7470A	30859

Prep Batch: 31128

Lab Sample ID	Client Sample ID	Prep Type	Matrix	Method	Prep Batch
140-15490-1	AP-2019-1 (30-31)	Total/NA	Solid	3050B	
140-15490-2	AP-2019-2 (35-36)	Total/NA	Solid	3050B	
140-15490-3	AP-2019-3 (18-19)	Total/NA	Solid	3050B	
MB 140-31128/14-A	Method Blank	Total/NA	Solid	3050B	
LCS 140-31128/15-A	Lab Control Sample	Total/NA	Solid	3050B	
140-15490-1 MS	AP-2019-1 (30-31)	Total/NA	Solid	3050B	
140-15490-1 MSD	AP-2019-1 (30-31)	Total/NA	Solid	3050B	

SEP Batch: 31148

Lab Sample ID	Client Sample ID	Prep Type	Matrix	Method	Prep Batch
140-15490-1	AP-2019-1 (30-31)	Step 1	Solid	Exchangeable	
140-15490-2	AP-2019-2 (35-36)	Step 1	Solid	Exchangeable	
140-15490-3	AP-2019-3 (18-19)	Step 1	Solid	Exchangeable	
MB 140-31148/13-B ^4	Method Blank	Step 1	Solid	Exchangeable	
LCS 140-31148/14-B ^5	Lab Control Sample	Step 1	Solid	Exchangeable	
LCSD 140-31148/15-B ^5	Lab Control Sample Dup	Step 1	Solid	Exchangeable	
140-15490-1 DU	AP-2019-1 (30-31)	Step 1	Solid	Exchangeable	

Eurofins TestAmerica, Knoxville

QC Association Summary

Client: Golder Associates Inc.
Project/Site: Martin Lake Ash Ponds - SEP + Totals

Job ID: 140-15490-1

Metals

Prep Batch: 31252

Lab Sample ID	Client Sample ID	Prep Type	Matrix	Method	Prep Batch
140-15490-1	AP-2019-1 (30-31)	Step 1	Solid	3010A	31148
140-15490-2	AP-2019-2 (35-36)	Step 1	Solid	3010A	31148
140-15490-3	AP-2019-3 (18-19)	Step 1	Solid	3010A	31148
MB 140-31148/13-B ^4	Method Blank	Step 1	Solid	3010A	31148
LCS 140-31148/14-B ^5	Lab Control Sample	Step 1	Solid	3010A	31148
LCSD 140-31148/15-B ^5	Lab Control Sample Dup	Step 1	Solid	3010A	31148
140-15490-1 DU	AP-2019-1 (30-31)	Step 1	Solid	3010A	31148

SEP Batch: 31253

Lab Sample ID	Client Sample ID	Prep Type	Matrix	Method	Prep Batch
140-15490-1	AP-2019-1 (30-31)	Step 2	Solid	Carbonate	
140-15490-2	AP-2019-2 (35-36)	Step 2	Solid	Carbonate	
140-15490-3	AP-2019-3 (18-19)	Step 2	Solid	Carbonate	
MB 140-31253/13-B ^3	Method Blank	Step 2	Solid	Carbonate	
LCS 140-31253/14-B ^5	Lab Control Sample	Step 2	Solid	Carbonate	
LCSD 140-31253/15-B ^5	Lab Control Sample Dup	Step 2	Solid	Carbonate	
140-15490-1 DU	AP-2019-1 (30-31)	Step 2	Solid	Carbonate	

Prep Batch: 31256

Lab Sample ID	Client Sample ID	Prep Type	Matrix	Method	Prep Batch
140-15490-1	AP-2019-1 (30-31)	Step 2	Solid	3010A	31253
140-15490-2	AP-2019-2 (35-36)	Step 2	Solid	3010A	31253
140-15490-3	AP-2019-3 (18-19)	Step 2	Solid	3010A	31253
MB 140-31253/13-B ^3	Method Blank	Step 2	Solid	3010A	31253
LCS 140-31253/14-B ^5	Lab Control Sample	Step 2	Solid	3010A	31253
LCSD 140-31253/15-B ^5	Lab Control Sample Dup	Step 2	Solid	3010A	31253
140-15490-1 DU	AP-2019-1 (30-31)	Step 2	Solid	3010A	31253

SEP Batch: 31257

Lab Sample ID	Client Sample ID	Prep Type	Matrix	Method	Prep Batch
140-15490-1	AP-2019-1 (30-31)	Step 3	Solid	Non-Crystalline	
140-15490-2	AP-2019-2 (35-36)	Step 3	Solid	Non-Crystalline	
140-15490-3	AP-2019-3 (18-19)	Step 3	Solid	Non-Crystalline	
MB 140-31257/13-B	Method Blank	Step 3	Solid	Non-Crystalline	
LCS 140-31257/14-B	Lab Control Sample	Step 3	Solid	Non-Crystalline	
LCSD 140-31257/15-B	Lab Control Sample Dup	Step 3	Solid	Non-Crystalline	
140-15490-1 DU	AP-2019-1 (30-31)	Step 3	Solid	Non-Crystalline	

Prep Batch: 31338

Lab Sample ID	Client Sample ID	Prep Type	Matrix	Method	Prep Batch
140-15490-1	AP-2019-1 (30-31)	Step 3	Solid	3010A	31257
140-15490-2	AP-2019-2 (35-36)	Step 3	Solid	3010A	31257
140-15490-3	AP-2019-3 (18-19)	Step 3	Solid	3010A	31257
MB 140-31257/13-B	Method Blank	Step 3	Solid	3010A	31257
LCS 140-31257/14-B	Lab Control Sample	Step 3	Solid	3010A	31257
LCSD 140-31257/15-B	Lab Control Sample Dup	Step 3	Solid	3010A	31257
140-15490-1 DU	AP-2019-1 (30-31)	Step 3	Solid	3010A	31257

SEP Batch: 31341

Lab Sample ID	Client Sample ID	Prep Type	Matrix	Method	Prep Batch
140-15490-1	AP-2019-1 (30-31)	Step 4	Solid	Metal Hydroxide	

Eurofins TestAmerica, Knoxville

QC Association Summary

Client: Golder Associates Inc.
Project/Site: Martin Lake Ash Ponds - SEP + Totals

Job ID: 140-15490-1

Metals (Continued)

SEP Batch: 31341 (Continued)

Lab Sample ID	Client Sample ID	Prep Type	Matrix	Method	Prep Batch
140-15490-2	AP-2019-2 (35-36)	Step 4	Solid	Metal Hydroxide	
140-15490-3	AP-2019-3 (18-19)	Step 4	Solid	Metal Hydroxide	
MB 140-31341/13-B	Method Blank	Step 4	Solid	Metal Hydroxide	
LCS 140-31341/14-B	Lab Control Sample	Step 4	Solid	Metal Hydroxide	
LCSD 140-31341/15-B	Lab Control Sample Dup	Step 4	Solid	Metal Hydroxide	
140-15490-1 DU	AP-2019-1 (30-31)	Step 4	Solid	Metal Hydroxide	

Prep Batch: 31360

Lab Sample ID	Client Sample ID	Prep Type	Matrix	Method	Prep Batch
140-15490-1	AP-2019-1 (30-31)	Step 4	Solid	3010A	31341
140-15490-2	AP-2019-2 (35-36)	Step 4	Solid	3010A	31341
140-15490-3	AP-2019-3 (18-19)	Step 4	Solid	3010A	31341
MB 140-31341/13-B	Method Blank	Step 4	Solid	3010A	31341
LCS 140-31341/14-B	Lab Control Sample	Step 4	Solid	3010A	31341
LCSD 140-31341/15-B	Lab Control Sample Dup	Step 4	Solid	3010A	31341
140-15490-1 DU	AP-2019-1 (30-31)	Step 4	Solid	3010A	31341

SEP Batch: 31436

Lab Sample ID	Client Sample ID	Prep Type	Matrix	Method	Prep Batch
140-15490-1	AP-2019-1 (30-31)	Step 5	Solid	Organic-Bound	
140-15490-2	AP-2019-2 (35-36)	Step 5	Solid	Organic-Bound	
140-15490-3	AP-2019-3 (18-19)	Step 5	Solid	Organic-Bound	
MB 140-31436/13-B ^5	Method Blank	Step 5	Solid	Organic-Bound	
LCS 140-31436/14-B ^5	Lab Control Sample	Step 5	Solid	Organic-Bound	
LCSD 140-31436/15-B ^5	Lab Control Sample Dup	Step 5	Solid	Organic-Bound	
140-15490-1 DU	AP-2019-1 (30-31)	Step 5	Solid	Organic-Bound	

Prep Batch: 31500

Lab Sample ID	Client Sample ID	Prep Type	Matrix	Method	Prep Batch
140-15490-1	AP-2019-1 (30-31)	Step 5	Solid	3010A	31436
140-15490-2	AP-2019-2 (35-36)	Step 5	Solid	3010A	31436
140-15490-3	AP-2019-3 (18-19)	Step 5	Solid	3010A	31436
MB 140-31436/13-B ^5	Method Blank	Step 5	Solid	3010A	31436
LCS 140-31436/14-B ^5	Lab Control Sample	Step 5	Solid	3010A	31436
LCSD 140-31436/15-B ^5	Lab Control Sample Dup	Step 5	Solid	3010A	31436
140-15490-1 DU	AP-2019-1 (30-31)	Step 5	Solid	3010A	31436

SEP Batch: 31502

Lab Sample ID	Client Sample ID	Prep Type	Matrix	Method	Prep Batch
140-15490-1	AP-2019-1 (30-31)	Step 6	Solid	Acid/Sulfide	
140-15490-2	AP-2019-2 (35-36)	Step 6	Solid	Acid/Sulfide	
140-15490-3	AP-2019-3 (18-19)	Step 6	Solid	Acid/Sulfide	
MB 140-31502/13-A	Method Blank	Step 6	Solid	Acid/Sulfide	
LCS 140-31502/14-A	Lab Control Sample	Step 6	Solid	Acid/Sulfide	
LCSD 140-31502/15-A	Lab Control Sample Dup	Step 6	Solid	Acid/Sulfide	
140-15490-1 DU	AP-2019-1 (30-31)	Step 6	Solid	Acid/Sulfide	

Analysis Batch: 31553

Lab Sample ID	Client Sample ID	Prep Type	Matrix	Method	Prep Batch
140-15490-1	AP-2019-1 (30-31)	Total/NA	Solid	6010B	31128
140-15490-2	AP-2019-2 (35-36)	Total/NA	Solid	6010B	31128

Eurofins TestAmerica, Knoxville

QC Association Summary

Client: Golder Associates Inc.
 Project/Site: Martin Lake Ash Ponds - SEP + Totals

Job ID: 140-15490-1

Metals (Continued)

Analysis Batch: 31553 (Continued)

Lab Sample ID	Client Sample ID	Prep Type	Matrix	Method	Prep Batch
140-15490-3	AP-2019-3 (18-19)	Total/NA	Solid	6010B	31128
MB 140-31128/14-A	Method Blank	Total/NA	Solid	6010B	31128
LCS 140-31128/15-A	Lab Control Sample	Total/NA	Solid	6010B	31128
140-15490-1 MS	AP-2019-1 (30-31)	Total/NA	Solid	6010B	31128
140-15490-1 MSD	AP-2019-1 (30-31)	Total/NA	Solid	6010B	31128

Analysis Batch: 31604

Lab Sample ID	Client Sample ID	Prep Type	Matrix	Method	Prep Batch
140-15490-1	AP-2019-1 (30-31)	Step 1	Solid	6010B SEP	31252
140-15490-1	AP-2019-1 (30-31)	Step 2	Solid	6010B SEP	31256
140-15490-1	AP-2019-1 (30-31)	Step 3	Solid	6010B SEP	31338
140-15490-1	AP-2019-1 (30-31)	Step 4	Solid	6010B SEP	31360
140-15490-2	AP-2019-2 (35-36)	Step 1	Solid	6010B SEP	31252
140-15490-2	AP-2019-2 (35-36)	Step 2	Solid	6010B SEP	31256
140-15490-2	AP-2019-2 (35-36)	Step 3	Solid	6010B SEP	31338
140-15490-2	AP-2019-2 (35-36)	Step 4	Solid	6010B SEP	31360
140-15490-3	AP-2019-3 (18-19)	Step 1	Solid	6010B SEP	31252
140-15490-3	AP-2019-3 (18-19)	Step 2	Solid	6010B SEP	31256
140-15490-3	AP-2019-3 (18-19)	Step 3	Solid	6010B SEP	31338
140-15490-3	AP-2019-3 (18-19)	Step 4	Solid	6010B SEP	31360
MB 140-31148/13-B ^4	Method Blank	Step 1	Solid	6010B SEP	31252
MB 140-31253/13-B ^3	Method Blank	Step 2	Solid	6010B SEP	31256
MB 140-31257/13-B	Method Blank	Step 3	Solid	6010B SEP	31338
MB 140-31341/13-B	Method Blank	Step 4	Solid	6010B SEP	31360
LCS 140-31148/14-B ^5	Lab Control Sample	Step 1	Solid	6010B SEP	31252
LCS 140-31253/14-B ^5	Lab Control Sample	Step 2	Solid	6010B SEP	31256
LCS 140-31257/14-B	Lab Control Sample	Step 3	Solid	6010B SEP	31338
LCS 140-31341/14-B	Lab Control Sample	Step 4	Solid	6010B SEP	31360
LCSD 140-31148/15-B ^5	Lab Control Sample Dup	Step 1	Solid	6010B SEP	31252
LCSD 140-31253/15-B ^5	Lab Control Sample Dup	Step 2	Solid	6010B SEP	31256
LCSD 140-31257/15-B	Lab Control Sample Dup	Step 3	Solid	6010B SEP	31338
LCSD 140-31341/15-B	Lab Control Sample Dup	Step 4	Solid	6010B SEP	31360
140-15490-1 DU	AP-2019-1 (30-31)	Step 1	Solid	6010B SEP	31252
140-15490-1 DU	AP-2019-1 (30-31)	Step 2	Solid	6010B SEP	31256
140-15490-1 DU	AP-2019-1 (30-31)	Step 3	Solid	6010B SEP	31338
140-15490-1 DU	AP-2019-1 (30-31)	Step 4	Solid	6010B SEP	31360

Prep Batch: 31615

Lab Sample ID	Client Sample ID	Prep Type	Matrix	Method	Prep Batch
140-15490-1	AP-2019-1 (30-31)	Step 7	Solid	Residual	
140-15490-2	AP-2019-2 (35-36)	Step 7	Solid	Residual	
140-15490-3	AP-2019-3 (18-19)	Step 7	Solid	Residual	
MB 140-31615/13-A	Method Blank	Step 7	Solid	Residual	
LCS 140-31615/14-A	Lab Control Sample	Step 7	Solid	Residual	
LCSD 140-31615/15-A	Lab Control Sample Dup	Step 7	Solid	Residual	
140-15490-1 DU	AP-2019-1 (30-31)	Step 7	Solid	Residual	

Analysis Batch: 31651

Lab Sample ID	Client Sample ID	Prep Type	Matrix	Method	Prep Batch
140-15490-1	AP-2019-1 (30-31)	Step 5	Solid	6010B SEP	31500
140-15490-1	AP-2019-1 (30-31)	Step 6	Solid	6010B SEP	31502

QC Association Summary

Client: Golder Associates Inc.
 Project/Site: Martin Lake Ash Ponds - SEP + Totals

Job ID: 140-15490-1

Metals (Continued)

Analysis Batch: 31651 (Continued)

Lab Sample ID	Client Sample ID	Prep Type	Matrix	Method	Prep Batch
140-15490-2	AP-2019-2 (35-36)	Step 5	Solid	6010B SEP	31500
140-15490-2	AP-2019-2 (35-36)	Step 6	Solid	6010B SEP	31502
140-15490-3	AP-2019-3 (18-19)	Step 5	Solid	6010B SEP	31500
140-15490-3	AP-2019-3 (18-19)	Step 6	Solid	6010B SEP	31502
MB 140-31436/13-B ^5	Method Blank	Step 5	Solid	6010B SEP	31500
MB 140-31502/13-A	Method Blank	Step 6	Solid	6010B SEP	31502
LCS 140-31436/14-B ^5	Lab Control Sample	Step 5	Solid	6010B SEP	31500
LCS 140-31502/14-A	Lab Control Sample	Step 6	Solid	6010B SEP	31502
LCSD 140-31436/15-B ^5	Lab Control Sample Dup	Step 5	Solid	6010B SEP	31500
LCSD 140-31502/15-A	Lab Control Sample Dup	Step 6	Solid	6010B SEP	31502
140-15490-1 DU	AP-2019-1 (30-31)	Step 5	Solid	6010B SEP	31500
140-15490-1 DU	AP-2019-1 (30-31)	Step 6	Solid	6010B SEP	31502

Analysis Batch: 31713

Lab Sample ID	Client Sample ID	Prep Type	Matrix	Method	Prep Batch
140-15490-1	AP-2019-1 (30-31)	Step 7	Solid	6010B SEP	31615
140-15490-1	AP-2019-1 (30-31)	Step 7	Solid	6010B SEP	31615
140-15490-1	AP-2019-1 (30-31)	Step 7	Solid	6010B SEP	31615
140-15490-1	AP-2019-1 (30-31)	Total/NA	Solid	6010B	30683
140-15490-1	AP-2019-1 (30-31)	Total/NA	Solid	6010B	30683
140-15490-1	AP-2019-1 (30-31)	Total/NA	Solid	6010B	30683
140-15490-2	AP-2019-2 (35-36)	Step 7	Solid	6010B SEP	31615
140-15490-2	AP-2019-2 (35-36)	Step 7	Solid	6010B SEP	31615
140-15490-2	AP-2019-2 (35-36)	Step 7	Solid	6010B SEP	31615
140-15490-2	AP-2019-2 (35-36)	Total/NA	Solid	6010B	30683
140-15490-2	AP-2019-2 (35-36)	Total/NA	Solid	6010B	30683
140-15490-2	AP-2019-2 (35-36)	Total/NA	Solid	6010B	30683
140-15490-3	AP-2019-3 (18-19)	Step 7	Solid	6010B SEP	31615
140-15490-3	AP-2019-3 (18-19)	Step 7	Solid	6010B SEP	31615
140-15490-3	AP-2019-3 (18-19)	Step 7	Solid	6010B SEP	31615
140-15490-3	AP-2019-3 (18-19)	Total/NA	Solid	6010B	30683
140-15490-3	AP-2019-3 (18-19)	Total/NA	Solid	6010B	30683
140-15490-3	AP-2019-3 (18-19)	Total/NA	Solid	6010B	30683
MB 140-30683/13-A	Method Blank	Total/NA	Solid	6010B	30683
MB 140-31615/13-A	Method Blank	Step 7	Solid	6010B SEP	31615
LCS 140-30683/14-A	Lab Control Sample	Total/NA	Solid	6010B	30683
LCS 140-31615/14-A	Lab Control Sample	Step 7	Solid	6010B SEP	31615
LCSD 140-30683/15-A	Lab Control Sample Dup	Total/NA	Solid	6010B	30683
LCSD 140-31615/15-A	Lab Control Sample Dup	Step 7	Solid	6010B SEP	31615
140-15490-1 DU	AP-2019-1 (30-31)	Step 7	Solid	6010B SEP	31615
140-15490-1 DU	AP-2019-1 (30-31)	Step 7	Solid	6010B SEP	31615
140-15490-1 DU	AP-2019-1 (30-31)	Step 7	Solid	6010B SEP	31615
140-15490-1 DU	AP-2019-1 (30-31)	Total/NA	Solid	6010B	30683
140-15490-1 DU	AP-2019-1 (30-31)	Total/NA	Solid	6010B	30683
140-15490-1 DU	AP-2019-1 (30-31)	Total/NA	Solid	6010B	30683

Analysis Batch: 31744

Lab Sample ID	Client Sample ID	Prep Type	Matrix	Method	Prep Batch
140-15490-1	AP-2019-1 (30-31)	Sum of Steps 1-7	Solid	6010B SEP	
140-15490-2	AP-2019-2 (35-36)	Sum of Steps 1-7	Solid	6010B SEP	
140-15490-3	AP-2019-3 (18-19)	Sum of Steps 1-7	Solid	6010B SEP	

QC Association Summary

Client: Golder Associates Inc.
Project/Site: Martin Lake Ash Ponds - SEP + Totals

Job ID: 140-15490-1

General Chemistry

Analysis Batch: 30602

Lab Sample ID	Client Sample ID	Prep Type	Matrix	Method	Prep Batch
140-15490-1	AP-2019-1 (30-31)	Total/NA	Solid	Moisture	
140-15490-2	AP-2019-2 (35-36)	Total/NA	Solid	Moisture	
140-15490-3	AP-2019-3 (18-19)	Total/NA	Solid	Moisture	
140-15490-1 DU	AP-2019-1 (30-31)	Total/NA	Solid	Moisture	

LUMINANT

- 1
- 2
- 3
- 4
- 5
- 6
- 7
- 8
- 9
- 10
- 11
- 12
- 13

Lab Chronicle

Client: Golder Associates Inc.
Project/Site: Martin Lake Ash Ponds - SEP + Totals

Job ID: 140-15490-1

Client Sample ID: AP-2019-1 (30-31)

Lab Sample ID: 140-15490-1

Date Collected: 06/03/19 11:36

Matrix: Solid

Date Received: 06/05/19 09:20

Prep Type	Batch Type	Batch Method	Run	Dil Factor	Initial Amount	Final Amount	Batch Number	Prepared or Analyzed	Analyst	Lab
Sum of Steps 1-7	Analysis	6010B SEP		1			31744	07/16/19 17:31	CLJ	TAL KNX
		Instrument ID: NOEQUIP								
Total/NA	Analysis	Moisture		1			30602	06/06/19 14:52	BKD	TAL KNX
		Instrument ID: W3								

Client Sample ID: AP-2019-1 (30-31)

Lab Sample ID: 140-15490-1

Date Collected: 06/03/19 11:36

Matrix: Solid

Date Received: 06/05/19 09:20

Percent Solids: 76.0

Prep Type	Batch Type	Batch Method	Run	Dil Factor	Initial Amount	Final Amount	Batch Number	Prepared or Analyzed	Analyst	Lab
Total/NA	Prep	3050B			0.536 g	50 mL	31128	06/26/19 08:00	KNC	TAL KNX
Total/NA	Analysis	6010B		1			31553	07/10/19 12:59	KNC	TAL KNX
		Instrument ID: DUO								
Total/NA	Prep	Total			1.000 g	50 mL	30683	06/11/19 08:00	KNC	TAL KNX
Total/NA	Analysis	6010B		1			31713	07/15/19 14:24	KNC	TAL KNX
		Instrument ID: DUO								
Total/NA	Prep	Total			1.000 g	50 mL	30683	06/11/19 08:00	KNC	TAL KNX
Total/NA	Analysis	6010B		10			31713	07/15/19 15:45	KNC	TAL KNX
		Instrument ID: DUO								
Total/NA	Prep	Total			1.000 g	50 mL	30683	06/11/19 08:00	KNC	TAL KNX
Total/NA	Analysis	6010B		2			31713	07/15/19 18:28	KNC	TAL KNX
		Instrument ID: DUO								
Step 1	SEP	Exchangeable			5.000 g	25 mL	31148	06/26/19 09:47	KNC	TAL KNX
Step 1	Prep	3010A			5 mL	50 mL	31252	06/29/19 08:00	KNC	TAL KNX
Step 1	Analysis	6010B SEP		4			31604	07/11/19 12:49	KNC	TAL KNX
		Instrument ID: DUO								
Step 2	SEP	Carbonate			5.000 g	25 mL	31253	06/29/19 08:00	KNC	TAL KNX
Step 2	Prep	3010A			5 mL	50 mL	31256	06/30/19 08:00	KNC	TAL KNX
Step 2	Analysis	6010B SEP		3			31604	07/11/19 14:21	KNC	TAL KNX
		Instrument ID: DUO								
Step 3	SEP	Non-Crystalline			5.000 g	25 mL	31257	06/30/19 08:00	KNC	TAL KNX
Step 3	Prep	3010A			5 mL	50 mL	31338	07/02/19 08:00	KNC	TAL KNX
Step 3	Analysis	6010B SEP		1			31604	07/11/19 16:06	KNC	TAL KNX
		Instrument ID: DUO								
Step 4	SEP	Metal Hydroxide			5.000 g	25 mL	31341	07/02/19 09:00	KNC	TAL KNX
Step 4	Prep	3010A			5 mL	50 mL	31360	07/03/19 08:00	KNC	TAL KNX
Step 4	Analysis	6010B SEP		1			31604	07/11/19 17:49	KNC	TAL KNX
		Instrument ID: DUO								
Step 5	SEP	Organic-Bound			5.000 g	75 mL	31436	07/08/19 07:00	KNC	TAL KNX
Step 5	Prep	3010A			5 mL	50 mL	31500	07/10/19 08:00	KNC	TAL KNX
Step 5	Analysis	6010B SEP		5			31651	07/12/19 11:54	KNC	TAL KNX
		Instrument ID: DUO								
Step 6	SEP	Acid/Sulfide			5.000 g	250 mL	31502	07/10/19 08:00	KNC	TAL KNX
Step 6	Analysis	6010B SEP		1			31651	07/12/19 13:29	KNC	TAL KNX
		Instrument ID: DUO								

Eurofins TestAmerica, Knoxville

Lab Chronicle

Client: Golder Associates Inc.
Project/Site: Martin Lake Ash Ponds - SEP + Totals

Job ID: 140-15490-1

Client Sample ID: AP-2019-1 (30-31)

Lab Sample ID: 140-15490-1

Date Collected: 06/03/19 11:36

Matrix: Solid

Date Received: 06/05/19 09:20

Percent Solids: 76.0

Prep Type	Batch Type	Batch Method	Run	Dil Factor	Initial Amount	Final Amount	Batch Number	Prepared or Analyzed	Analyst	Lab
Step 7	Prep	Residual			1.000 g	50 mL	31615	07/12/19 09:08	KNC	TAL KNX
Step 7	Analysis	6010B SEP		1			31713	07/15/19 11:39	KNC	TAL KNX
Instrument ID: DUO										
Step 7	Prep	Residual			1.000 g	50 mL	31615	07/12/19 09:08	KNC	TAL KNX
Step 7	Analysis	6010B SEP		10			31713	07/15/19 13:08	KNC	TAL KNX
Instrument ID: DUO										
Step 7	Prep	Residual			1.000 g	50 mL	31615	07/12/19 09:08	KNC	TAL KNX
Step 7	Analysis	6010B SEP		2			31713	07/15/19 17:11	KNC	TAL KNX
Instrument ID: DUO										
Total/NA	Prep	Total			1.000 g	50 mL	30683	06/11/19 08:00	KNC	TAL KNX
Total/NA	Prep	7470A			5.0 mL	50.0 mL	30859	06/16/19 08:00	DKW	TAL KNX
Total/NA	Analysis	7470A		1			30868	06/16/19 14:04	DKW	TAL KNX
Instrument ID: HG										

Client Sample ID: AP-2019-2 (35-36)

Lab Sample ID: 140-15490-2

Date Collected: 06/03/19 13:20

Matrix: Solid

Date Received: 06/05/19 09:20

Prep Type	Batch Type	Batch Method	Run	Dil Factor	Initial Amount	Final Amount	Batch Number	Prepared or Analyzed	Analyst	Lab
Sum of Steps 1-7	Analysis	6010B SEP		1			31744	07/16/19 17:31	CLJ	TAL KNX
Instrument ID: NOEQUIP										
Total/NA	Analysis	Moisture		1			30602	06/06/19 14:52	BKD	TAL KNX
Instrument ID: W3										

Client Sample ID: AP-2019-2 (35-36)

Lab Sample ID: 140-15490-2

Date Collected: 06/03/19 13:20

Matrix: Solid

Date Received: 06/05/19 09:20

Percent Solids: 78.5

Prep Type	Batch Type	Batch Method	Run	Dil Factor	Initial Amount	Final Amount	Batch Number	Prepared or Analyzed	Analyst	Lab
Total/NA	Prep	3050B			0.527 g	50 mL	31128	06/26/19 08:00	KNC	TAL KNX
Total/NA	Analysis	6010B		1			31553	07/10/19 13:13	KNC	TAL KNX
Instrument ID: DUO										
Total/NA	Prep	Total			1.000 g	50 mL	30683	06/11/19 08:00	KNC	TAL KNX
Total/NA	Analysis	6010B		1			31713	07/15/19 14:36	KNC	TAL KNX
Instrument ID: DUO										
Total/NA	Prep	Total			1.000 g	50 mL	30683	06/11/19 08:00	KNC	TAL KNX
Total/NA	Analysis	6010B		10			31713	07/15/19 16:10	KNC	TAL KNX
Instrument ID: DUO										
Total/NA	Prep	Total			1.000 g	50 mL	30683	06/11/19 08:00	KNC	TAL KNX
Total/NA	Analysis	6010B		5			31713	07/15/19 18:38	KNC	TAL KNX
Instrument ID: DUO										
Step 1	SEP	Exchangeable			5.000 g	25 mL	31148	06/26/19 09:47	KNC	TAL KNX
Step 1	Prep	3010A			5 mL	50 mL	31252	06/29/19 08:00	KNC	TAL KNX
Step 1	Analysis	6010B SEP		4			31604	07/11/19 12:59	KNC	TAL KNX
Instrument ID: DUO										

Eurofins TestAmerica, Knoxville

Lab Chronicle

Client: Golder Associates Inc.
Project/Site: Martin Lake Ash Ponds - SEP + Totals

Job ID: 140-15490-1

Client Sample ID: AP-2019-2 (35-36)

Lab Sample ID: 140-15490-2

Date Collected: 06/03/19 13:20

Matrix: Solid

Date Received: 06/05/19 09:20

Percent Solids: 78.5

Prep Type	Batch Type	Batch Method	Run	Dil Factor	Initial Amount	Final Amount	Batch Number	Prepared or Analyzed	Analyst	Lab
Step 2	SEP	Carbonate			5.000 g	25 mL	31253	06/29/19 08:00	KNC	TAL KNX
Step 2	Prep	3010A			5 mL	50 mL	31256	06/30/19 08:00	KNC	TAL KNX
Step 2	Analysis	6010B SEP		3			31604	07/11/19 14:42	KNC	TAL KNX
Instrument ID: DUO										
Step 3	SEP	Non-Crystalline			5.000 g	25 mL	31257	06/30/19 08:00	KNC	TAL KNX
Step 3	Prep	3010A			5 mL	50 mL	31338	07/02/19 08:00	KNC	TAL KNX
Step 3	Analysis	6010B SEP		1			31604	07/11/19 16:16	KNC	TAL KNX
Instrument ID: DUO										
Step 4	SEP	Metal Hydroxide			5.000 g	25 mL	31341	07/02/19 09:00	KNC	TAL KNX
Step 4	Prep	3010A			5 mL	50 mL	31360	07/03/19 08:00	KNC	TAL KNX
Step 4	Analysis	6010B SEP		1			31604	07/11/19 17:59	KNC	TAL KNX
Instrument ID: DUO										
Step 5	SEP	Organic-Bound			5.000 g	75 mL	31436	07/08/19 07:00	KNC	TAL KNX
Step 5	Prep	3010A			5 mL	50 mL	31500	07/10/19 08:00	KNC	TAL KNX
Step 5	Analysis	6010B SEP		5			31651	07/12/19 12:05	KNC	TAL KNX
Instrument ID: DUO										
Step 6	SEP	Acid/Sulfide			5.000 g	250 mL	31502	07/10/19 08:00	KNC	TAL KNX
Step 6	Analysis	6010B SEP		1			31651	07/12/19 13:49	KNC	TAL KNX
Instrument ID: DUO										
Step 7	Prep	Residual			1.000 g	50 mL	31615	07/12/19 09:08	KNC	TAL KNX
Step 7	Analysis	6010B SEP		1			31713	07/15/19 12:05	KNC	TAL KNX
Instrument ID: DUO										
Step 7	Prep	Residual			1.000 g	50 mL	31615	07/12/19 09:08	KNC	TAL KNX
Step 7	Analysis	6010B SEP		10			31713	07/15/19 13:19	KNC	TAL KNX
Instrument ID: DUO										
Step 7	Prep	Residual			1.000 g	50 mL	31615	07/12/19 09:08	KNC	TAL KNX
Step 7	Analysis	6010B SEP		2			31713	07/15/19 17:21	KNC	TAL KNX
Instrument ID: DUO										
Total/NA	Prep	Total			1.000 g	50 mL	30683	06/11/19 08:00	KNC	TAL KNX
Total/NA	Prep	7470A			5.0 mL	50.0 mL	30859	06/16/19 08:00	DKW	TAL KNX
Total/NA	Analysis	7470A		1			30868	06/16/19 14:09	DKW	TAL KNX
Instrument ID: HG										

Client Sample ID: AP-2019-3 (18-19)

Lab Sample ID: 140-15490-3

Date Collected: 06/03/19 15:20

Matrix: Solid

Date Received: 06/05/19 09:20

Prep Type	Batch Type	Batch Method	Run	Dil Factor	Initial Amount	Final Amount	Batch Number	Prepared or Analyzed	Analyst	Lab
Sum of Steps 1-7	Analysis	6010B SEP		1			31744	07/16/19 17:31	CLJ	TAL KNX
Instrument ID: NOEQUIP										
Total/NA	Analysis	Moisture		1			30602	06/06/19 14:52	BKD	TAL KNX
Instrument ID: W3										

Lab Chronicle

Client: Golder Associates Inc.
 Project/Site: Martin Lake Ash Ponds - SEP + Totals

Job ID: 140-15490-1

Client Sample ID: AP-2019-3 (18-19)

Lab Sample ID: 140-15490-3

Date Collected: 06/03/19 15:20

Matrix: Solid

Date Received: 06/05/19 09:20

Percent Solids: 80.0

Prep Type	Batch Type	Batch Method	Run	Dil Factor	Initial Amount	Final Amount	Batch Number	Prepared or Analyzed	Analyst	Lab
Total/NA	Prep	3050B			0.527 g	50 mL	31128	06/26/19 08:00	KNC	TAL KNX
Total/NA	Analysis	6010B		1			31553	07/10/19 13:18	KNC	TAL KNX
Instrument ID: DUO										
Total/NA	Prep	Total			1.000 g	50 mL	30683	06/11/19 08:00	KNC	TAL KNX
Total/NA	Analysis	6010B		1			31713	07/15/19 14:41	KNC	TAL KNX
Instrument ID: DUO										
Total/NA	Prep	Total			1.000 g	50 mL	30683	06/11/19 08:00	KNC	TAL KNX
Total/NA	Analysis	6010B		10			31713	07/15/19 16:15	KNC	TAL KNX
Instrument ID: DUO										
Total/NA	Prep	Total			1.000 g	50 mL	30683	06/11/19 08:00	KNC	TAL KNX
Total/NA	Analysis	6010B		5			31713	07/15/19 18:43	KNC	TAL KNX
Instrument ID: DUO										
Step 1	SEP	Exchangeable			5.000 g	25 mL	31148	06/26/19 09:47	KNC	TAL KNX
Step 1	Prep	3010A			5 mL	50 mL	31252	06/29/19 08:00	KNC	TAL KNX
Step 1	Analysis	6010B SEP		4			31604	07/11/19 13:04	KNC	TAL KNX
Instrument ID: DUO										
Step 2	SEP	Carbonate			5.000 g	25 mL	31253	06/29/19 08:00	KNC	TAL KNX
Step 2	Prep	3010A			5 mL	50 mL	31256	06/30/19 08:00	KNC	TAL KNX
Step 2	Analysis	6010B SEP		3			31604	07/11/19 14:47	KNC	TAL KNX
Instrument ID: DUO										
Step 3	SEP	Non-Crystalline			5.000 g	25 mL	31257	06/30/19 08:00	KNC	TAL KNX
Step 3	Prep	3010A			5 mL	50 mL	31338	07/02/19 08:00	KNC	TAL KNX
Step 3	Analysis	6010B SEP		1			31604	07/11/19 16:21	KNC	TAL KNX
Instrument ID: DUO										
Step 4	SEP	Metal Hydroxide			5.000 g	25 mL	31341	07/02/19 09:00	KNC	TAL KNX
Step 4	Prep	3010A			5 mL	50 mL	31360	07/03/19 08:00	KNC	TAL KNX
Step 4	Analysis	6010B SEP		1			31604	07/11/19 18:04	KNC	TAL KNX
Instrument ID: DUO										
Step 5	SEP	Organic-Bound			5.000 g	75 mL	31436	07/08/19 07:00	KNC	TAL KNX
Step 5	Prep	3010A			5 mL	50 mL	31500	07/10/19 08:00	KNC	TAL KNX
Step 5	Analysis	6010B SEP		5			31651	07/12/19 12:10	KNC	TAL KNX
Instrument ID: DUO										
Step 6	SEP	Acid/Sulfide			5.000 g	250 mL	31502	07/10/19 08:00	KNC	TAL KNX
Step 6	Analysis	6010B SEP		1			31651	07/12/19 13:55	KNC	TAL KNX
Instrument ID: DUO										
Step 7	Prep	Residual			1.000 g	50 mL	31615	07/12/19 09:08	KNC	TAL KNX
Step 7	Analysis	6010B SEP		1			31713	07/15/19 12:11	KNC	TAL KNX
Instrument ID: DUO										
Step 7	Prep	Residual			1.000 g	50 mL	31615	07/12/19 09:08	KNC	TAL KNX
Step 7	Analysis	6010B SEP		10			31713	07/15/19 13:24	KNC	TAL KNX
Instrument ID: DUO										
Step 7	Prep	Residual			1.000 g	50 mL	31615	07/12/19 09:08	KNC	TAL KNX
Step 7	Analysis	6010B SEP		2			31713	07/15/19 17:27	KNC	TAL KNX
Instrument ID: DUO										

Lab Chronicle

Client: Golder Associates Inc.
Project/Site: Martin Lake Ash Ponds - SEP + Totals

Job ID: 140-15490-1

Client Sample ID: AP-2019-3 (18-19)

Lab Sample ID: 140-15490-3

Date Collected: 06/03/19 15:20

Matrix: Solid

Date Received: 06/05/19 09:20

Percent Solids: 80.0

Prep Type	Batch Type	Batch Method	Run	Dil Factor	Initial Amount	Final Amount	Batch Number	Prepared or Analyzed	Analyst	Lab
Total/NA	Prep	Total			1.000 g	50 mL	30683	06/11/19 08:00	KNC	TAL KNX
Total/NA	Prep	7470A			5.0 mL	50.0 mL	30859	06/16/19 08:00	DKW	TAL KNX
Total/NA	Analysis	7470A		1			30868	06/16/19 14:17	DKW	TAL KNX
Instrument ID: HG										

Client Sample ID: Method Blank

Lab Sample ID: MB 140-30683/13-A

Date Collected: N/A

Matrix: Solid

Date Received: N/A

Prep Type	Batch Type	Batch Method	Run	Dil Factor	Initial Amount	Final Amount	Batch Number	Prepared or Analyzed	Analyst	Lab
Total/NA	Prep	Total			1.000 g	50 mL	30683	06/11/19 08:00	KNC	TAL KNX
Total/NA	Analysis	6010B		1			31713	07/15/19 11:13	KNC	TAL KNX
Instrument ID: DUO										

Client Sample ID: Method Blank

Lab Sample ID: MB 140-30683/13-B

Date Collected: N/A

Matrix: Solid

Date Received: N/A

Prep Type	Batch Type	Batch Method	Run	Dil Factor	Initial Amount	Final Amount	Batch Number	Prepared or Analyzed	Analyst	Lab
Total/NA	Prep	Total			1.000 g	50 mL	30683	06/11/19 08:00	KNC	TAL KNX
Total/NA	Prep	7470A			5.0 mL	50.0 mL	30859	06/16/19 08:00	DKW	TAL KNX
Total/NA	Analysis	7470A		1			30868	06/16/19 13:56	DKW	TAL KNX
Instrument ID: HG										

Client Sample ID: Method Blank

Lab Sample ID: MB 140-31128/14-A

Date Collected: N/A

Matrix: Solid

Date Received: N/A

Prep Type	Batch Type	Batch Method	Run	Dil Factor	Initial Amount	Final Amount	Batch Number	Prepared or Analyzed	Analyst	Lab
Total/NA	Prep	3050B			0.500 g	50 mL	31128	06/26/19 08:00	KNC	TAL KNX
Total/NA	Analysis	6010B		1			31553	07/10/19 11:42	KNC	TAL KNX
Instrument ID: DUO										

Client Sample ID: Method Blank

Lab Sample ID: MB 140-31148/13-B ^4

Date Collected: N/A

Matrix: Solid

Date Received: N/A

Prep Type	Batch Type	Batch Method	Run	Dil Factor	Initial Amount	Final Amount	Batch Number	Prepared or Analyzed	Analyst	Lab
Step 1	SEP	Exchangeable			5.000 g	25 mL	31148	06/26/19 09:47	KNC	TAL KNX
Step 1	Prep	3010A			5 mL	50 mL	31252	06/29/19 08:00	KNC	TAL KNX
Step 1	Analysis	6010B SEP		4			31604	07/11/19 12:33	KNC	TAL KNX
Instrument ID: DUO										

Lab Chronicle

Client: Golder Associates Inc.
Project/Site: Martin Lake Ash Ponds - SEP + Totals

Job ID: 140-15490-1

Client Sample ID: Method Blank

Date Collected: N/A

Date Received: N/A

Lab Sample ID: MB 140-31253/13-B ^3

Matrix: Solid

Prep Type	Batch Type	Batch Method	Run	Dil Factor	Initial Amount	Final Amount	Batch Number	Prepared or Analyzed	Analyst	Lab
Step 2	SEP	Carbonate			5.000 g	25 mL	31253	06/29/19 08:00	KNC	TAL KNX
Step 2	Prep	3010A			5 mL	50 mL	31256	06/30/19 08:00	KNC	TAL KNX
Step 2	Analysis	6010B SEP		3			31604	07/11/19 14:06	KNC	TAL KNX
Instrument ID: DUO										

Client Sample ID: Method Blank

Date Collected: N/A

Date Received: N/A

Lab Sample ID: MB 140-31257/13-B

Matrix: Solid

Prep Type	Batch Type	Batch Method	Run	Dil Factor	Initial Amount	Final Amount	Batch Number	Prepared or Analyzed	Analyst	Lab
Step 3	SEP	Non-Crystalline			5.000 g	25 mL	31257	06/30/19 08:00	KNC	TAL KNX
Step 3	Prep	3010A			5 mL	50 mL	31338	07/02/19 08:00	KNC	TAL KNX
Step 3	Analysis	6010B SEP		1			31604	07/11/19 15:50	KNC	TAL KNX
Instrument ID: DUO										

Client Sample ID: Method Blank

Date Collected: N/A

Date Received: N/A

Lab Sample ID: MB 140-31341/13-B

Matrix: Solid

Prep Type	Batch Type	Batch Method	Run	Dil Factor	Initial Amount	Final Amount	Batch Number	Prepared or Analyzed	Analyst	Lab
Step 4	SEP	Metal Hydroxide			5.000 g	25 mL	31341	07/02/19 09:00	KNC	TAL KNX
Step 4	Prep	3010A			5 mL	50 mL	31360	07/03/19 08:00	KNC	TAL KNX
Step 4	Analysis	6010B SEP		1			31604	07/11/19 17:24	KNC	TAL KNX
Instrument ID: DUO										

Client Sample ID: Method Blank

Date Collected: N/A

Date Received: N/A

Lab Sample ID: MB 140-31436/13-B ^5

Matrix: Solid

Prep Type	Batch Type	Batch Method	Run	Dil Factor	Initial Amount	Final Amount	Batch Number	Prepared or Analyzed	Analyst	Lab
Step 5	SEP	Organic-Bound			5.000 g	75 mL	31436	07/08/19 07:00	KNC	TAL KNX
Step 5	Prep	3010A			5 mL	50 mL	31500	07/10/19 08:00	KNC	TAL KNX
Step 5	Analysis	6010B SEP		5			31651	07/12/19 11:39	KNC	TAL KNX
Instrument ID: DUO										

Client Sample ID: Method Blank

Date Collected: N/A

Date Received: N/A

Lab Sample ID: MB 140-31502/13-A

Matrix: Solid

Prep Type	Batch Type	Batch Method	Run	Dil Factor	Initial Amount	Final Amount	Batch Number	Prepared or Analyzed	Analyst	Lab
Step 6	SEP	Acid/Sulfide			5.000 g	250 mL	31502	07/10/19 08:00	KNC	TAL KNX
Step 6	Analysis	6010B SEP		1			31651	07/12/19 13:14	KNC	TAL KNX
Instrument ID: DUO										

Lab Chronicle

Client: Golder Associates Inc.
 Project/Site: Martin Lake Ash Ponds - SEP + Totals

Job ID: 140-15490-1

Client Sample ID: Method Blank

Lab Sample ID: MB 140-31615/13-A

Date Collected: N/A

Matrix: Solid

Date Received: N/A

Prep Type	Batch Type	Batch Method	Run	Dil Factor	Initial Amount	Final Amount	Batch Number	Prepared or Analyzed	Analyst	Lab
Step 7	Prep	Residual			1.000 g	50 mL	31615	07/12/19 09:08	KNC	TAL KNX
Step 7	Analysis	6010B SEP		1			31713	07/15/19 10:58	KNC	TAL KNX
Instrument ID: DUO										

Client Sample ID: Lab Control Sample

Lab Sample ID: LCS 140-30683/14-A

Date Collected: N/A

Matrix: Solid

Date Received: N/A

Prep Type	Batch Type	Batch Method	Run	Dil Factor	Initial Amount	Final Amount	Batch Number	Prepared or Analyzed	Analyst	Lab
Total/NA	Prep	Total			1.000 g	50 mL	30683	06/11/19 08:00	KNC	TAL KNX
Total/NA	Analysis	6010B		1			31713	07/15/19 11:19	KNC	TAL KNX
Instrument ID: DUO										

Client Sample ID: Lab Control Sample

Lab Sample ID: LCS 140-30683/14-B

Date Collected: N/A

Matrix: Solid

Date Received: N/A

Prep Type	Batch Type	Batch Method	Run	Dil Factor	Initial Amount	Final Amount	Batch Number	Prepared or Analyzed	Analyst	Lab
Total/NA	Prep	Total			1.000 g	50 mL	30683	06/11/19 08:00	KNC	TAL KNX
Total/NA	Prep	7470A			5.0 mL	50.0 mL	30859	06/16/19 08:00	DKW	TAL KNX
Total/NA	Analysis	7470A		1			30868	06/16/19 13:59	DKW	TAL KNX
Instrument ID: HG										

Client Sample ID: Lab Control Sample

Lab Sample ID: LCS 140-31128/15-A

Date Collected: N/A

Matrix: Solid

Date Received: N/A

Prep Type	Batch Type	Batch Method	Run	Dil Factor	Initial Amount	Final Amount	Batch Number	Prepared or Analyzed	Analyst	Lab
Total/NA	Prep	3050B			0.500 g	50 mL	31128	06/26/19 08:00	KNC	TAL KNX
Total/NA	Analysis	6010B		1			31553	07/10/19 11:47	KNC	TAL KNX
Instrument ID: DUO										

Client Sample ID: Lab Control Sample

Lab Sample ID: LCS 140-31148/14-B ^5

Date Collected: N/A

Matrix: Solid

Date Received: N/A

Prep Type	Batch Type	Batch Method	Run	Dil Factor	Initial Amount	Final Amount	Batch Number	Prepared or Analyzed	Analyst	Lab
Step 1	SEP	Exchangeable			5.000 g	25 mL	31148	06/26/19 09:47	KNC	TAL KNX
Step 1	Prep	3010A			5 mL	50 mL	31252	06/29/19 08:00	KNC	TAL KNX
Step 1	Analysis	6010B SEP		5			31604	07/11/19 12:38	KNC	TAL KNX
Instrument ID: DUO										

Lab Chronicle

Client: Golder Associates Inc.
Project/Site: Martin Lake Ash Ponds - SEP + Totals

Job ID: 140-15490-1

Client Sample ID: Lab Control Sample

Lab Sample ID: LCS 140-31253/14-B ^5

Date Collected: N/A

Matrix: Solid

Date Received: N/A

Prep Type	Batch Type	Batch Method	Run	Dil Factor	Initial Amount	Final Amount	Batch Number	Prepared or Analyzed	Analyst	Lab
Step 2	SEP	Carbonate			5.000 g	25 mL	31253	06/29/19 08:00	KNC	TAL KNX
Step 2	Prep	3010A			5 mL	50 mL	31256	06/30/19 08:00	KNC	TAL KNX
Step 2	Analysis	6010B SEP		5			31604	07/11/19 14:11	KNC	TAL KNX
Instrument ID: DUO										

Client Sample ID: Lab Control Sample

Lab Sample ID: LCS 140-31257/14-B

Date Collected: N/A

Matrix: Solid

Date Received: N/A

Prep Type	Batch Type	Batch Method	Run	Dil Factor	Initial Amount	Final Amount	Batch Number	Prepared or Analyzed	Analyst	Lab
Step 3	SEP	Non-Crystalline			5.000 g	25 mL	31257	06/30/19 08:00	KNC	TAL KNX
Step 3	Prep	3010A			5 mL	50 mL	31338	07/02/19 08:00	KNC	TAL KNX
Step 3	Analysis	6010B SEP		1			31604	07/11/19 15:56	KNC	TAL KNX
Instrument ID: DUO										

Client Sample ID: Lab Control Sample

Lab Sample ID: LCS 140-31341/14-B

Date Collected: N/A

Matrix: Solid

Date Received: N/A

Prep Type	Batch Type	Batch Method	Run	Dil Factor	Initial Amount	Final Amount	Batch Number	Prepared or Analyzed	Analyst	Lab
Step 4	SEP	Metal Hydroxide			5.000 g	25 mL	31341	07/02/19 09:00	KNC	TAL KNX
Step 4	Prep	3010A			5 mL	50 mL	31360	07/03/19 08:00	KNC	TAL KNX
Step 4	Analysis	6010B SEP		1			31604	07/11/19 17:29	KNC	TAL KNX
Instrument ID: DUO										

Client Sample ID: Lab Control Sample

Lab Sample ID: LCS 140-31436/14-B ^5

Date Collected: N/A

Matrix: Solid

Date Received: N/A

Prep Type	Batch Type	Batch Method	Run	Dil Factor	Initial Amount	Final Amount	Batch Number	Prepared or Analyzed	Analyst	Lab
Step 5	SEP	Organic-Bound			5.000 g	75 mL	31436	07/08/19 07:00	KNC	TAL KNX
Step 5	Prep	3010A			5 mL	50 mL	31500	07/10/19 08:00	KNC	TAL KNX
Step 5	Analysis	6010B SEP		5			31651	07/12/19 11:44	KNC	TAL KNX
Instrument ID: DUO										

Client Sample ID: Lab Control Sample

Lab Sample ID: LCS 140-31502/14-A

Date Collected: N/A

Matrix: Solid

Date Received: N/A

Prep Type	Batch Type	Batch Method	Run	Dil Factor	Initial Amount	Final Amount	Batch Number	Prepared or Analyzed	Analyst	Lab
Step 6	SEP	Acid/Sulfide			5.000 g	250 mL	31502	07/10/19 08:00	KNC	TAL KNX
Step 6	Analysis	6010B SEP		1			31651	07/12/19 13:19	KNC	TAL KNX
Instrument ID: DUO										

Lab Chronicle

Client: Golder Associates Inc.
 Project/Site: Martin Lake Ash Ponds - SEP + Totals

Job ID: 140-15490-1

Client Sample ID: Lab Control Sample

Lab Sample ID: LCS 140-31615/14-A

Date Collected: N/A

Matrix: Solid

Date Received: N/A

Prep Type	Batch Type	Batch Method	Run	Dil Factor	Initial Amount	Final Amount	Batch Number	Prepared or Analyzed	Analyst	Lab
Step 7	Prep	Residual			1.000 g	50 mL	31615	07/12/19 09:08	KNC	TAL KNX
Step 7	Analysis	6010B SEP		1			31713	07/15/19 11:03	KNC	TAL KNX
Instrument ID: DUO										

Client Sample ID: Lab Control Sample Dup

Lab Sample ID: LCSD 140-30683/15-A

Date Collected: N/A

Matrix: Solid

Date Received: N/A

Prep Type	Batch Type	Batch Method	Run	Dil Factor	Initial Amount	Final Amount	Batch Number	Prepared or Analyzed	Analyst	Lab
Total/NA	Prep	Total			1.000 g	50 mL	30683	06/11/19 08:00	KNC	TAL KNX
Total/NA	Analysis	6010B		1			31713	07/15/19 11:24	KNC	TAL KNX
Instrument ID: DUO										

Client Sample ID: Lab Control Sample Dup

Lab Sample ID: LCSD 140-30683/15-B

Date Collected: N/A

Matrix: Solid

Date Received: N/A

Prep Type	Batch Type	Batch Method	Run	Dil Factor	Initial Amount	Final Amount	Batch Number	Prepared or Analyzed	Analyst	Lab
Total/NA	Prep	Total			1.000 g	50 mL	30683	06/11/19 08:00	KNC	TAL KNX
Total/NA	Prep	7470A			5.0 mL	50.0 mL	30859	06/16/19 08:00	DKW	TAL KNX
Total/NA	Analysis	7470A		1			30868	06/16/19 14:02	DKW	TAL KNX
Instrument ID: HG										

Client Sample ID: Lab Control Sample Dup

Lab Sample ID: LCSD 140-31148/15-B ^5

Date Collected: N/A

Matrix: Solid

Date Received: N/A

Prep Type	Batch Type	Batch Method	Run	Dil Factor	Initial Amount	Final Amount	Batch Number	Prepared or Analyzed	Analyst	Lab
Step 1	SEP	Exchangeable			5.000 g	25 mL	31148	06/26/19 09:47	KNC	TAL KNX
Step 1	Prep	3010A			5 mL	50 mL	31252	06/29/19 08:00	KNC	TAL KNX
Step 1	Analysis	6010B SEP		5			31604	07/11/19 12:43	KNC	TAL KNX
Instrument ID: DUO										

Client Sample ID: Lab Control Sample Dup

Lab Sample ID: LCSD 140-31253/15-B ^5

Date Collected: N/A

Matrix: Solid

Date Received: N/A

Prep Type	Batch Type	Batch Method	Run	Dil Factor	Initial Amount	Final Amount	Batch Number	Prepared or Analyzed	Analyst	Lab
Step 2	SEP	Carbonate			5.000 g	25 mL	31253	06/29/19 08:00	KNC	TAL KNX
Step 2	Prep	3010A			5 mL	50 mL	31256	06/30/19 08:00	KNC	TAL KNX
Step 2	Analysis	6010B SEP		5			31604	07/11/19 14:16	KNC	TAL KNX
Instrument ID: DUO										

Lab Chronicle

Client: Golder Associates Inc.
 Project/Site: Martin Lake Ash Ponds - SEP + Totals

Job ID: 140-15490-1

Client Sample ID: Lab Control Sample Dup

Lab Sample ID: LCSD 140-31257/15-B

Date Collected: N/A

Matrix: Solid

Date Received: N/A

Prep Type	Batch Type	Batch Method	Run	Dil Factor	Initial Amount	Final Amount	Batch Number	Prepared or Analyzed	Analyst	Lab
Step 3	SEP	Non-Crystalline			5.000 g	25 mL	31257	06/30/19 08:00	KNC	TAL KNX
Step 3	Prep	3010A			5 mL	50 mL	31338	07/02/19 08:00	KNC	TAL KNX
Step 3	Analysis	6010B SEP		1			31604	07/11/19 16:01	KNC	TAL KNX
Instrument ID: DUO										

Client Sample ID: Lab Control Sample Dup

Lab Sample ID: LCSD 140-31341/15-B

Date Collected: N/A

Matrix: Solid

Date Received: N/A

Prep Type	Batch Type	Batch Method	Run	Dil Factor	Initial Amount	Final Amount	Batch Number	Prepared or Analyzed	Analyst	Lab
Step 4	SEP	Metal Hydroxide			5.000 g	25 mL	31341	07/02/19 09:00	KNC	TAL KNX
Step 4	Prep	3010A			5 mL	50 mL	31360	07/03/19 08:00	KNC	TAL KNX
Step 4	Analysis	6010B SEP		1			31604	07/11/19 17:44	KNC	TAL KNX
Instrument ID: DUO										

Client Sample ID: Lab Control Sample Dup

Lab Sample ID: LCSD 140-31436/15-B ^5

Date Collected: N/A

Matrix: Solid

Date Received: N/A

Prep Type	Batch Type	Batch Method	Run	Dil Factor	Initial Amount	Final Amount	Batch Number	Prepared or Analyzed	Analyst	Lab
Step 5	SEP	Organic-Bound			5.000 g	75 mL	31436	07/08/19 07:00	KNC	TAL KNX
Step 5	Prep	3010A			5 mL	50 mL	31500	07/10/19 08:00	KNC	TAL KNX
Step 5	Analysis	6010B SEP		5			31651	07/12/19 11:49	KNC	TAL KNX
Instrument ID: DUO										

Client Sample ID: Lab Control Sample Dup

Lab Sample ID: LCSD 140-31502/15-A

Date Collected: N/A

Matrix: Solid

Date Received: N/A

Prep Type	Batch Type	Batch Method	Run	Dil Factor	Initial Amount	Final Amount	Batch Number	Prepared or Analyzed	Analyst	Lab
Step 6	SEP	Acid/Sulfide			5.000 g	250 mL	31502	07/10/19 08:00	KNC	TAL KNX
Step 6	Analysis	6010B SEP		1			31651	07/12/19 13:24	KNC	TAL KNX
Instrument ID: DUO										

Client Sample ID: Lab Control Sample Dup

Lab Sample ID: LCSD 140-31615/15-A

Date Collected: N/A

Matrix: Solid

Date Received: N/A

Prep Type	Batch Type	Batch Method	Run	Dil Factor	Initial Amount	Final Amount	Batch Number	Prepared or Analyzed	Analyst	Lab
Step 7	Prep	Residual			1.000 g	50 mL	31615	07/12/19 09:08	KNC	TAL KNX
Step 7	Analysis	6010B SEP		1			31713	07/15/19 11:08	KNC	TAL KNX
Instrument ID: DUO										

Lab Chronicle

Client: Golder Associates Inc.
Project/Site: Martin Lake Ash Ponds - SEP + Totals

Job ID: 140-15490-1

Client Sample ID: AP-2019-1 (30-31)

Lab Sample ID: 140-15490-1 MS

Date Collected: 06/03/19 11:36

Matrix: Solid

Date Received: 06/05/19 09:20

Percent Solids: 76.0

Prep Type	Batch Type	Batch Method	Run	Dil Factor	Initial Amount	Final Amount	Batch Number	Prepared or Analyzed	Analyst	Lab
Total/NA	Prep	3050B			0.530 g	50 mL	31128	06/26/19 08:00	KNC	TAL KNX
Total/NA	Analysis	6010B		1			31553	07/10/19 13:04	KNC	TAL KNX
Instrument ID: DUO										

Client Sample ID: AP-2019-1 (30-31)

Lab Sample ID: 140-15490-1 MSD

Date Collected: 06/03/19 11:36

Matrix: Solid

Date Received: 06/05/19 09:20

Percent Solids: 76.0

Prep Type	Batch Type	Batch Method	Run	Dil Factor	Initial Amount	Final Amount	Batch Number	Prepared or Analyzed	Analyst	Lab
Total/NA	Prep	3050B			0.539 g	50 mL	31128	06/26/19 08:00	KNC	TAL KNX
Total/NA	Analysis	6010B		1			31553	07/10/19 13:08	KNC	TAL KNX
Instrument ID: DUO										

Client Sample ID: AP-2019-1 (30-31)

Lab Sample ID: 140-15490-1 DU

Date Collected: 06/03/19 11:36

Matrix: Solid

Date Received: 06/05/19 09:20

Prep Type	Batch Type	Batch Method	Run	Dil Factor	Initial Amount	Final Amount	Batch Number	Prepared or Analyzed	Analyst	Lab
Total/NA	Analysis	Moisture		1			30602	06/06/19 14:52	BKD	TAL KNX
Instrument ID: W3										

Client Sample ID: AP-2019-1 (30-31)

Lab Sample ID: 140-15490-1 DU

Date Collected: 06/03/19 11:36

Matrix: Solid

Date Received: 06/05/19 09:20

Percent Solids: 76.0

Prep Type	Batch Type	Batch Method	Run	Dil Factor	Initial Amount	Final Amount	Batch Number	Prepared or Analyzed	Analyst	Lab
Total/NA	Prep	Total			1.000 g	50 mL	30683	06/11/19 08:00	KNC	TAL KNX
Total/NA	Analysis	6010B		1			31713	07/15/19 14:30	KNC	TAL KNX
Instrument ID: DUO										
Total/NA	Prep	Total			1.000 g	50 mL	30683	06/11/19 08:00	KNC	TAL KNX
Total/NA	Analysis	6010B		10			31713	07/15/19 15:50	KNC	TAL KNX
Instrument ID: DUO										
Total/NA	Prep	Total			1.000 g	50 mL	30683	06/11/19 08:00	KNC	TAL KNX
Total/NA	Analysis	6010B		2			31713	07/15/19 18:33	KNC	TAL KNX
Instrument ID: DUO										
Step 1	SEP	Exchangeable			5.000 g	25 mL	31148	06/26/19 09:47	KNC	TAL KNX
Step 1	Prep	3010A			5 mL	50 mL	31252	06/29/19 08:00	KNC	TAL KNX
Step 1	Analysis	6010B SEP		4			31604	07/11/19 12:54	KNC	TAL KNX
Instrument ID: DUO										
Step 2	SEP	Carbonate			5.000 g	25 mL	31253	06/29/19 08:00	KNC	TAL KNX
Step 2	Prep	3010A			5 mL	50 mL	31256	06/30/19 08:00	KNC	TAL KNX
Step 2	Analysis	6010B SEP		3			31604	07/11/19 14:37	KNC	TAL KNX
Instrument ID: DUO										

Lab Chronicle

Client: Golder Associates Inc.
 Project/Site: Martin Lake Ash Ponds - SEP + Totals

Job ID: 140-15490-1

Client Sample ID: AP-2019-1 (30-31)

Lab Sample ID: 140-15490-1 DU

Date Collected: 06/03/19 11:36

Matrix: Solid

Date Received: 06/05/19 09:20

Percent Solids: 76.0

Prep Type	Batch Type	Batch Method	Run	Dil Factor	Initial Amount	Final Amount	Batch Number	Prepared or Analyzed	Analyst	Lab
Step 3	SEP	Non-Crystalline			5.000 g	25 mL	31257	06/30/19 08:00	KNC	TAL KNX
Step 3	Prep	3010A			5 mL	50 mL	31338	07/02/19 08:00	KNC	TAL KNX
Step 3	Analysis	6010B SEP		1			31604	07/11/19 16:11	KNC	TAL KNX
Instrument ID: DUO										
Step 4	SEP	Metal Hydroxide			5.000 g	25 mL	31341	07/02/19 09:00	KNC	TAL KNX
Step 4	Prep	3010A			5 mL	50 mL	31360	07/03/19 08:00	KNC	TAL KNX
Step 4	Analysis	6010B SEP		1			31604	07/11/19 17:54	KNC	TAL KNX
Instrument ID: DUO										
Step 5	SEP	Organic-Bound			5.000 g	75 mL	31436	07/08/19 07:00	KNC	TAL KNX
Step 5	Prep	3010A			5 mL	50 mL	31500	07/10/19 08:00	KNC	TAL KNX
Step 5	Analysis	6010B SEP		5			31651	07/12/19 12:00	KNC	TAL KNX
Instrument ID: DUO										
Step 6	SEP	Acid/Sulfide			5.000 g	250 mL	31502	07/10/19 08:00	KNC	TAL KNX
Step 6	Analysis	6010B SEP		1			31651	07/12/19 13:44	KNC	TAL KNX
Instrument ID: DUO										
Step 7	Prep	Residual			1.000 g	50 mL	31615	07/12/19 09:08	KNC	TAL KNX
Step 7	Analysis	6010B SEP		1			31713	07/15/19 12:00	KNC	TAL KNX
Instrument ID: DUO										
Step 7	Prep	Residual			1.000 g	50 mL	31615	07/12/19 09:08	KNC	TAL KNX
Step 7	Analysis	6010B SEP		10			31713	07/15/19 13:14	KNC	TAL KNX
Instrument ID: DUO										
Step 7	Prep	Residual			1.000 g	50 mL	31615	07/12/19 09:08	KNC	TAL KNX
Step 7	Analysis	6010B SEP		2			31713	07/15/19 17:16	KNC	TAL KNX
Instrument ID: DUO										
Total/NA	Prep	Total			1.000 g	50 mL	30683	06/11/19 08:00	KNC	TAL KNX
Total/NA	Prep	7470A			5.0 mL	50.0 mL	30859	06/16/19 08:00	DKW	TAL KNX
Total/NA	Analysis	7470A		1			30868	06/16/19 14:06	DKW	TAL KNX
Instrument ID: HG										

Laboratory References:

TAL KNX = Eurofins TestAmerica, Knoxville, 5815 Middlebrook Pike, Knoxville, TN 37921, TEL (865)291-3000

Method Summary

Client: Golder Associates Inc.
Project/Site: Martin Lake Ash Ponds - SEP + Totals

Job ID: 140-15490-1

Method	Method Description	Protocol	Laboratory
6010B	Metals (ICP)	SW846	TAL KNX
6010B	SEP Metals (ICP) - Total	SW846	TAL KNX
6010B SEP	SEP Metals (ICP)	SW846	TAL KNX
7470A	SEP Mercury (CVAA) - Total	SW846	TAL KNX
Moisture	Percent Moisture	EPA	TAL KNX
3010A	Preparation, Total Metals	SW846	TAL KNX
3050B	Preparation, Metals	SW846	TAL KNX
7470A	Preparation, Mercury	SW846	TAL KNX
Acid/Sulfide	Sequential Extraction Procedure, Acid/Sulfide Fraction	TAL-KNOX	TAL KNX
Carbonate	Sequential Extraction Procedure, Carbonate Fraction	TAL-KNOX	TAL KNX
Exchangeable	Sequential Extraction Procedure, Exchangeable Fraction	TAL-KNOX	TAL KNX
Metal Hydroxide	Sequential Extraction Procedure, Metal Hydroxide Fraction	TAL-KNOX	TAL KNX
Non-Crystalline	Sequential Extraction Procedure, Non-crystalline Materials	TAL-KNOX	TAL KNX
Organic-Bound	Sequential Extraction Procedure, Organic Bound Fraction	TAL-KNOX	TAL KNX
Residual	Sequential Extraction Procedure, Residual Fraction	TAL-KNOX	TAL KNX
Total	Preparation, Total Material	TAL-KNOX	TAL KNX

Protocol References:

EPA = US Environmental Protection Agency

SW846 = "Test Methods For Evaluating Solid Waste, Physical/Chemical Methods", Third Edition, November 1986 And Its Updates.

TAL-KNOX = TestAmerica Laboratories, Knoxville, Facility Standard Operating Procedure.

Laboratory References:

TAL KNX = Eurofins TestAmerica, Knoxville, 5815 Middlebrook Pike, Knoxville, TN 37921, TEL (865)291-3000

Sample Summary

Client: Golder Associates Inc.
Project/Site: Martin Lake Ash Ponds - SEP + Totals

Job ID: 140-15490-1

Lab Sample ID	Client Sample ID	Matrix	Collected	Received	Asset ID
140-15490-1	AP-2019-1 (30-31)	Solid	06/03/19 11:36	06/05/19 09:20	
140-15490-2	AP-2019-2 (35-36)	Solid	06/03/19 13:20	06/05/19 09:20	
140-15490-3	AP-2019-3 (18-19)	Solid	06/03/19 15:20	06/05/19 09:20	

LUMINANT

- 1
- 2
- 3
- 4
- 5
- 6
- 7
- 8
- 9
- 10
- 11
- 12
- 13

Chain of Custody Record

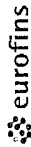

Client Information Client Contact: Will Vienne Company: Golder Associates Inc. Address: 2201 Double Creek Dr Suite 4004 City: Round Rock State, Zip: TX, 78664 Phone: 512-671-3434(Tel) Email: William_Vienne@golder.com Project Name: Martin Lake Ash Ponds - SEP + Totals Site:		Sampler: <u>Kelsey Worley</u> Phone: <u>281-750-2734</u> Lab PM: <u>Walker Wasmund, Terry</u> E-Mail: <u>terry.wasmund@testamericainc.com</u> Carrier Tracking No(s): COC No: 140-6683-2229.1 Page: Page 1 of 1 Job #:	
Due Date Requested: TAT Requested (days): <u>Standard</u> PO #: 19122434-C WO #: 1922434-C Project #: 14005268 SSOW#:		Analysis Requested	
Preservation Codes: A - HCl B - NaOH C - Zn Acetate D - Nitric Acid E - NaHSO4 F - MeOH G - Anchlor H - Ascorbic Acid I - Ice J - DI Water K - EDTA L - EDA Other:		Preservation Codes: M - Hexane N - None O - AsNaO2 P - Na2O4S Q - Na2SO3 R - Na2S2O3 S - H2SO4 T - TSP Dodecahydrate U - Acetone V - MCAA W - pH 4.5 Z - other (specify)	
Sample Identification AP-2019-1 (30-31) AP-2019-2 (35-36) AP-2019-3 (18-19) BT: 1.2°C FedEx Co. Custody Seal intact TK# 7876 7/28 2042 KW 6/5/19		Matrix (Newer, Spotted, On-water, Oil, BT=Blank, A=Air) S S S	
Sample Date 06/03/19 06/03/19 06/03/19		Sample Time 1136 1320 1520	
Sample Type (C=Comp, G=grab) C C C		Field Filtered Sample (Yes or No) X X X	
Performance/MS/SP (Ref or No) 6010B - SEP - 7-Step SEP (12 Metals) 6010B - Total B, Cr, Pb		Total Number of Containers On Ice " " " "	
Special Instructions/Note: Special Instructions/QC Requirements: Sample Disposal (A fee may be assessed if samples are retained longer than 1 month) <input type="checkbox"/> Return To Client <input checked="" type="checkbox"/> Disposal By Lab <input type="checkbox"/> Archive For _____ Months Deliverable Requested: <input type="checkbox"/> Flammable <input type="checkbox"/> Skin Irritant <input type="checkbox"/> Poison B <input type="checkbox"/> Unknown <input type="checkbox"/> Radiological Empty Kit Relinquished by: _____ Date: _____ Time: _____ Relinquished by: <u>Worley</u> Date/Time: <u>6/19/19 1245</u> Relinquished by: _____ Date/Time: _____ Relinquished by: _____ Date/Time: _____ Custody Seals Intact: <input type="checkbox"/> Yes <input type="checkbox"/> No Custody Seal No.:		Method of Shipment: _____ Received by: <u>WV</u> Date/Time: <u>6/19/19 1245</u> Received by: _____ Date/Time: _____ Received by: _____ Date/Time: _____ Cooler Temperature(s) °C and Other Remarks:	



TESTAMERICA KNOXVILLE SAMPLE RECEIPT/CONDITION UPON RECEIPT ANOMALY CHECKLIST

Review Items	Yes	No	NA	If No, what was the problem?	Comments/Actions Taken
1. Are the shipping containers intact?	/			<input type="checkbox"/> Containers, Broken	
2. Were ambient air containers received intact?			/	<input type="checkbox"/> Checked in lab	
3. The coolers/containers custody seal if present, is it intact?	/			<input type="checkbox"/> Yes <input type="checkbox"/> NA	
4. Is the cooler temperature within limits? (> freezing temp. of water to 6 °C, VOST: 10°C) Thermometer ID : <u>SLD</u> Correction factor: <u>F.O.</u>	/			<input type="checkbox"/> Cooler Out of Temp, Client Contacted, Proceed/Cancel <input type="checkbox"/> Cooler Out of Temp, Same Day Receipt	
5. Were all of the sample containers received intact?	/			<input type="checkbox"/> Containers, Broken	
6. Were samples received in appropriate containers?	/			<input type="checkbox"/> Containers, Improper; Client Contacted; Proceed/Cancel	
7. Do sample container labels match COC? (IDs, Dates, Times)	/			<input type="checkbox"/> COC & Samples Do Not Match <input type="checkbox"/> COC Incorrect/Incomplete <input type="checkbox"/> COC Not Received	
8. Were all of the samples listed on the COC received?	/			<input type="checkbox"/> Sample Received, Not on COC <input type="checkbox"/> Sample on COC, Not Received	
9. Is the date/time of sample collection noted?	/			<input type="checkbox"/> COC; No Date/Time; Client Contacted	Labeling Verified by: _____ Date: _____
10. Was the sampler identified on the COC?	/			<input type="checkbox"/> Sampler Not Listed on COC	
11. Is the client and project name/# identified?	/			<input type="checkbox"/> COC Incorrect/Incomplete	
12. Are tests/parameters listed for each sample?	/			<input type="checkbox"/> COC No tests on COC	
13. Is the matrix of the samples noted?	/			<input type="checkbox"/> COC Incorrect/Incomplete	pH test strip lot number: _____
14. Was COC relinquished? (Signed/Dated/Timed)	/			<input type="checkbox"/> COC Incorrect/Incomplete	Box 16A: pH Preservation Box 18A: Residual Chlorine
15. Were samples received within holding time?	/			<input type="checkbox"/> Holding Time - Receipt	Preservative: _____
16. Were samples received with correct chemical preservative (excluding Encore)?				<input type="checkbox"/> pH Adjusted, pH Included (See box 16A) <input type="checkbox"/> Incorrect Preservative	Lot Number: _____ Exp Date: _____ Analyst: _____
17. Were VOA samples received without headspace?			/	<input type="checkbox"/> Headspace (VOA only) <input type="checkbox"/> Residual Chlorine	Date: _____ Time: _____
18. Did you check for residual chlorine, if necessary? (e.g. 1613B, 1668) Chlorine test strip lot number: _____			/		
19. For 1613B water samples is pH<9?			/	<input type="checkbox"/> If no, notify lab to adjust	
20. For rad samples was sample activity info. Provided?			/	<input type="checkbox"/> Project missing info	
Project #: <u>1405267</u> PM Instructions: _____					

Sample Receiving Associate: [Signature] Date: 6/5/19 QA026R31.doc, 112618



APPENDIX C

**GROUNDWATER SAMPLING
RECORDS**

LUMINANT



GOLDER

RECORD OF WATER LEVEL READINGS

Project Name: LUMINANT - MISES - PONDS Location: THUM, TX Project No.: 19122262-C

Borehole No.	Date	Time	Measuring Device / Serial No.	Measurement Point (M.P)	Water Level Below M.P.	Correction To Survey Mark	Survey Mark Elevation	Water Level Elevation	By	Comments
H-31	5-14-19	0704	SOLINST	TOC	22.73				JTB	
H-32	5-14-19	0759	SOLINST	TOC	23.16				JTB	
H-27	5-14-19	0903	SOLINST	TOC	22.02				JTB	
H-29	5-14-19	1050	SOLINST	TOC	22.61				JTB	
H-28	5-14-19	1155	SOLINST	TOC	7.12				JTB	
H-26	5-14-19	1350	SOLINST	TOC	13.21				JTB	
H-33	5-14-19	1449	SOLINST	TOC	13.42				JTB	

GROUNDWATER SAMPLING RECORD

PAGE 1 of 1

Project Number: 19122262-C Project Name: LUMINAUT-MLSES

Date: 5-14-19

Sample Number: <u>H-26</u>	Starting Water Level (ft. BMP): <u>13.21</u>
Sampling Location (well ID, etc.): <u>H-26</u>	Casing Stickup (ft.): <u>-</u>
Sampled by: <u>JTB</u>	Starting Water Level (ft. BGL): <u>13.21</u>
Measuring Point (MP) of Well: <u>TOC/PVC</u>	Total Depth (ft. BGL): <u>-</u>
Screened Interval (ft. BGL): <u>-</u>	Casing Diameter (In ID): <u>2.0</u>
Filter Pack Interval (ft. BGL): <u>-</u>	Casing Volume (gal.): <u>-</u>

QUALITY ASSURANCE

METHODS (describe):

Cleaning Equipment:

Purging: peristaltic / bladder

Sampling: Dave

Disposal of Discharged Water: on site

INSTRUMENTS (Indicate make, model, I.D.)

Water Level: KECIC

Thermometer: HORIBA

pH Meter: HORIBA

Field Calibration: 7-4

Conductivity Meter: HORIBA

Field Calibration: 1413

Filter / Filter Size:

Other:

SAMPLING MEASUREMENTS

Time	Cum. Vol. (gal. or L)	Purge Rate (gal. or L/m)	Temp. (°C)	pH	Spec. Cond. (mmhos/cm)	D.O.	Redox (mV)	Turbidity & Color	Water Depth (ft BMP)
1401	-	.2	23.1	6.81	1730	0.86	-29	8.1	13.44
1406		↓	22.7	6.82	1760	0.63	-31	7.1	13.46
1413		↓	22.8	6.83	1760	0.64	-31	7.7	13.47

Water Level (ft. BMP) at End of Purge: 13.47

Sample Intake Depth (ft. BMP):

SAMPLE INVENTORY

Time	Bottles Collected			Filtration (Y/N)	Preservation	Remarks (quality control sample, other)
	Volume	Composition (G, P)	No.			
1425	250ML	P	1	N	-	GEN CHEM
1425	500ML	P	1	N	HNO ₃	METALS

Comments:

Pastor, Behling & Wheeler, LLC
 2201 Double Creek Dr., Suite 4004
 Round Rock, TX 78664
 (512) 671-3434 Fax (512) 671-3446

GROUNDWATER SAMPLING RECORD

PAGE 1 of 1

Project Number: 19122262-C Project Name: LUMINAUT-MLSES

Date: 5-14-19

Sample Number: H-27

Starting Water Level (ft. BMP): 22.02

Sampling Location (well ID, etc.): H-27

Casing Stickup (ft.): -

Sampled by: JTB

Starting Water Level (ft. BGL): 22.02

Measuring Point (MP) of Well: TOC/PVC

Total Depth (ft. BGL): -

Screened Interval (ft. BGL): -

Casing Diameter (In ID): 2.0

Filter Pack Interval (ft. BGL): -

Casing Volume (gal.): -

QUALITY ASSURANCE

METHODS (describe):

Cleaning Equipment:

Purging:

Disposal of Discharged Water:

aluminum 1/2 DI line
peristaltic / bladder
on site

Sampling:

Dame

INSTRUMENTS (Indicate make, model, I.d.)

Water Level:

pH Meter:

Conductivity Meter:

Filter / Filter Size:

Thermometer:

Field Calibration:

Field Calibration:

Other:

KECIC

HORIBA

HORIBA

HORIBA

7-4

14/3

SAMPLING MEASUREMENTS

Time	Cum. Vol. (gal. of L)	Purge Rate (gal. of L / m)	Temp. (°C)	pH	Spec. Cond. (mmhos/cm)	D.O	Redox (mV)	Turbidity & Color	Water Depth (ft BMP)
<u>0916</u>	<u>-</u>	<u>.2</u>	<u>22.1</u>	<u>6.74</u>	<u>1610</u>	<u>0.49</u>	<u>-79</u>	<u>7.7</u>	<u>22.23</u>
<u>0921</u>		<u>↓</u>	<u>22.4</u>	<u>6.77</u>	<u>1640</u>	<u>0.51</u>	<u>-81</u>	<u>7.9</u>	<u>22.24</u>
<u>0927</u>		<u>↓</u>	<u>22.4</u>	<u>6.78</u>	<u>1630</u>	<u>0.52</u>	<u>-82</u>	<u>7.9</u>	<u>22.23</u>

Water Level (ft. BMP) at End of Purge: 22.23

Sample Intake Depth (ft. BMP):

SAMPLE INVENTORY

Time	Bottles Collected			Filtration (Y/N)	Preservation	Remarks (quality control sample, other)
	Volume	Composition (G, P)	No.			
<u>0940</u>	<u>250ML</u>	<u>P</u>	<u>1</u>	<u>N</u>	<u>-</u>	<u>GEN CHEM</u>
<u>0940</u>	<u>500ML</u>	<u>P</u>	<u>1</u>	<u>N</u>	<u>HNO3</u>	<u>METALS</u>

Comments:

Pastor, Behling & Wheeler, LLC
2201 Double Creek Dr., Suite 4004
Round Rock, TX 78664
(512) 671-3434 Fax (512) 671-3446

GROUNDWATER SAMPLING RECORD

PAGE 1 of 1

Project Number: 19122262-C Project Name: LUMINAUT-MLSES Date: 5-14-19

Sample Number: H-28 Starting Water Level (ft. BMP): 7.12

Sampling Location (well ID, etc.): H-28 Casing Stickup (ft.): -

Sampled by: JTB Starting Water Level (ft. BGL): 7.12

Measuring Point (MP) of Well: TOC/PVC Total Depth (ft. BGL): -

Screened Interval (ft. BGL): - Casing Diameter (In ID): 2.0

Filter Pack Interval (ft. BGL): - Casing Volume (gal.): -

QUALITY ASSURANCE

METHODS (describe):

Cleaning Equipment:

Purging: peristaltic / bladder Sampling: Dame

Disposal of Discharged Water: on site

INSTRUMENTS (Indicate make, model, I.D.)

Water Level: KECIC Thermometer: HOEIBA

pH Meter: HOEIBA Field Calibration: 7-4

Conductivity Meter: HOEIBA Field Calibration: 1413

Filter / Filter Size: _____ Other: _____

SAMPLING MEASUREMENTS

Time	Cum. Vol. (gal. or L)	Purge Rate (gal. or L/m)	Temp (°C)	pH	Spec. Cond. (mmhos/cm)	D.O	Redox (mV)	Turbidity & Color	Water Depth (ft BMP)
1207	-	.2	22.6	6.29	1580	0.39	-34	3.8	7.29
1211		↓	22.9	6.31	1520	0.31	-39	4.6	7.31
1218		↓	22.9	6.32	1510	0.32	-39	4.8	7.32

Water Level (ft. BMP) at End of Purge: 7.32 Sample Intake Depth (ft. BMP): _____

SAMPLE INVENTORY

Time	Bottles Collected			Filtration (Y/N)	Preservation	Remarks (quality control sample, other)
	Volume	Composition (G, P)	No.			
1230	250ML	P	1	N	-	GEN CHEM
1230	500ML	P	1	N	HNO ₃	METALS

Comments: _____

Pastor, Behling & Wheeler, LLC
 2201 Double Creek Dr., Suite 4004
 Round Rock, TX 78664
 (512) 671-3434 Fax (512) 671-3446

GROUNDWATER SAMPLING RECORD

PAGE 1 of 1

Project Number: 19122262-C Project Name: LUMINAUT-MLSES

Date: 5-14-19

Sample Number: H-29

Starting Water Level (ft. BMP): 22.61

Sampling Location (well ID, etc.): H-29

Casing Stickup (ft.): -

Sampled by: JJB

Starting Water Level (ft. BGL): 22.61

Measuring Point (MP) of Well: TOC/PVC

Total Depth (ft. BGL): -

Screened Interval (ft. BGL): -

Casing Diameter (In. ID): 2.0

Filter Pack Interval (ft. BGL): -

Casing Volume (gal.): -

QUALITY ASSURANCE

METHODS (describe):

Cleaning Equipment:

Purging:

Sampling:

Disposal of Discharged Water:

acetonox & DI water
peristaltic / bladder Dame
on site

INSTRUMENTS (Indicate make, model, I.d.)

Water Level:

Thermometer:

pH Meter:

Field Calibration:

Conductivity Meter:

Field Calibration:

Filter / Filter Size:

Other:

KECIC HOEIBA
HOEIBA 7-4
HOEIBA 14/3

SAMPLING MEASUREMENTS

Time	Cum. Vol. (gal. or L)	Purge Rate (gal. or L/m)	Temp (°C)	pH	Spec. Cond. (mmhos/cm)	D.O	Redox (mV)	Turbidity & Color	Water Depth (ft BMP)
<u>1102</u>	<u>-</u>	<u>.2</u>	<u>21.9</u>	<u>6.46</u>	<u>1710</u>	<u>0.71</u>	<u>-86</u>	<u>7.2</u>	<u>22.88</u>
<u>1107</u>	<u>-</u>	<u>1</u>	<u>22.6</u>	<u>6.51</u>	<u>1730</u>	<u>0.62</u>	<u>-87</u>	<u>6.2</u>	<u>22.89</u>
<u>1114</u>	<u>-</u>	<u>1</u>	<u>22.7</u>	<u>6.52</u>	<u>1730</u>	<u>0.63</u>	<u>-87</u>	<u>6.1</u>	<u>22.89</u>

Water Level (ft. BMP) at End of Purge: 22.89

Sample Intake Depth (ft. BMP):

SAMPLE INVENTORY

Bottles Collected				Filtration (Y/N)	Preservation	Remarks (quality control sample, other)
Time	Volume	Composition (G, P)	No.			
<u>1125</u>	<u>250ML</u>	<u>P</u>	<u>1</u>	<u>N</u>	<u>-</u>	<u>GEN CHEM</u>
<u>1125</u>	<u>500ML</u>	<u>P</u>	<u>1</u>	<u>N</u>	<u>HNO3</u>	<u>METALS</u>

Comments:

Pastor, Behling & Wheeler, LLC
 2201 Double Creek Dr., Suite 4004
 Round Rock, TX 78664
 (512) 671-3434 Fax (512) 671-3446

GROUNDWATER SAMPLING RECORD

Project Number: 19122262-C Project Name: LUMINAUT-MLSES Date: 5-14-19

Sample Number: <u>H-31</u>	Starting Water Level (ft. BMP): <u>22.73</u>
Sampling Location (well ID, etc.): <u>H-31</u>	Casing Stickup (ft.): <u>-</u>
Sampled by: <u>JJB</u>	Starting Water Level (ft. BGL): <u>22.73</u>
Measuring Point (MP) of Well: <u>TOC/PVC</u>	Total Depth (ft. BGL): <u>-</u>
Screened Interval (ft. BGL): <u>-</u>	Casing Diameter (In ID): <u>2.0</u>
Filter Pack Interval (ft. BGL): <u>-</u>	Casing Volume (gal.): <u>-</u>

QUALITY ASSURANCE

METHODS (describe):

Cleaning Equipment:

Purging: peristaltic / bladder

Sampling: Dame

Disposal of Discharged Water: on site

INSTRUMENTS (Indicate make, model, I.D.)

Water Level: <u>KECIC</u>	Thermometer: <u>HORIBA</u>
pH Meter: <u>HORIBA</u>	Field Calibration: <u>7-4</u>
Conductivity Meter: <u>HORIBA</u>	Field Calibration: <u>14/3</u>
Filter / Filter Size:	Other:

SAMPLING MEASUREMENTS

Time	Cum. Vol. (gal. of L)	Purge Rate (gal. of L/m)	Temp (oC)	pH	Spec. Cond. (mmhos/cm)	D.O	Redox (mV)	Turbidity & Color	Water Depth (ft BMP)
0707	-	.2	22.6	6.49	1670	0.79	-76	4.6	22.92
0722		↓	22.5	6.41	1630	0.61	-77	5.8	22.93
0726		↓	22.4	6.42	1620	0.60	-77	5.6	22.93

Water Level (ft. BMP) at End of Purge: 22.93

Sample Intake Depth (ft. BMP):

SAMPLE INVENTORY

Time	Bottles Collected			Filtration (Y/N)	Preservation	Remarks (quality control sample, other)
	Volume	Composition (G, P)	No.			
0740	250ML	P	1	N	-	GEN CHEM
0740	500ML	P	1	N	HNO3	METALS

Comments:

Pastor, Behling & Wheeler, LLC
 2201 Double Creek Dr., Suite 4004
 Round Rock, TX 78664
 (512) 671-3434 Fax (512) 671-3446

GROUNDWATER SAMPLING RECORD

PAGE 1 of 1

Project Number: 19122262-C Project Name: LUMINAUT-MLSES

Date: 5-14-19

Sample Number: <u>H-32</u>	Starting Water Level (ft. BMP): <u>23.16</u>
Sampling Location (well ID, etc.): <u>H-32</u>	Casing Stickup (ft.): <u>-</u>
Sampled by: <u>JTB</u>	Starting Water Level (ft. BGL): <u>23.16</u>
Measuring Point (MP) of Well: <u>TOC/PUC</u>	Total Depth (ft. BGL): <u>-</u>
Screened Interval (ft. BGL): <u>-</u>	Casing Diameter (In ID): <u>2.0</u>
Filter Pack Interval (ft. BGL): <u>-</u>	Casing Volume (gal.): <u>-</u>

QUALITY ASSURANCE

METHODS (describe):

Cleaning Equipment:

Purging: peristaltic / bladder

Sampling: Dame

Disposal of Discharged Water: on site

INSTRUMENTS (Indicate make, model, I.d.)

Water Level: KECIC

Thermometer: HORIBA

pH Meter: HORIBA

Field Calibration: 7-4

Conductivity Meter: HORIBA

Field Calibration: 14/3

Filter / Filter Size:

Other:

SAMPLING MEASUREMENTS

Time	Cum. Vol. (gal. of L)	Purge Rate (gal. or L/m)	Temp (°C)	pH	Spec. Cond. (mmhos/cm)	D.O	Redox (mV)	Turbidity & Color	Water Depth (ft BMP)
0807	-	.2	22.4	5.99	1510	0.41	-71	4.8	23.34
0812		↓	22.7	6.01	1540	0.31	-76	9.2	23.35
0818		↓	22.6	6.02	1540	0.32	-77	8.7	23.35

Water Level (ft. BMP) at End of Purge: 23.35

Sample Intake Depth (ft. BMP):

SAMPLE INVENTORY

Time	Bottles Collected			Filtration (Y/N)	Preservation	Remarks (quality control sample, other)
	Volume	Composition (G, P)	No.			
0825	250ML	P	1	N	-	GEN CHEM
0825	500ML	P	1	N	HNO3	METALS

Comments:

Pastor, Behling & Wheeler, LLC
 2201 Double Creek Dr., Suite 4004
 Round Rock, TX 78664
 (512) 671-3434 Fax (512) 671-3446

GROUNDWATER SAMPLING RECORD

PAGE 1 of 1

Project Number: 19122262-C Project Name: LUMINAUT-MLSES

Date: 5-14-19

Sample Number: <u>H-33</u>	Starting Water Level (ft. BMP): <u>13.42</u>
Sampling Location (well ID, etc.): <u>H-33</u>	Casing Stickup (ft.): <u>-</u>
Sampled by: <u>JTB</u>	Starting Water Level (ft. BGL): <u>13.42</u>
Measuring Point (MP) of Well: <u>TOC/PVC</u>	Total Depth (ft. BGL): <u>-</u>
Screened Interval (ft. BGL): <u>-</u>	Casing Diameter (In ID): <u>2.0</u>
Filter Pack Interval (ft. BGL): <u>-</u>	Casing Volume (gal.): <u>-</u>

QUALITY ASSURANCE

METHODS (describe):

Cleaning Equipment:

Purging:

Disposal of Discharged Water:

aluminum & DI water
peristaltic / bladder Sampling: Dame
on site

INSTRUMENTS (Indicate make, model, I.D.)

Water Level:

pH Meter:

Conductivity Meter:

Filter / Filter Size:

Thermometer:

Field Calibration:

Field Calibration:

Other:

KECIC Thermometer: HORIBA
HORIBA Field Calibration: 7-4
HORIBA Field Calibration: 14/3

SAMPLING MEASUREMENTS

Time	Cum. Vol. (gal. of L)	Purge Rate (gal. of L/m)	Temp. (oC)	pH	Spec. Cond. (mmhos/cm)	D.O.	Redox (mV)	Turbidity & Color	Water Depth (ft BMP)
1501	-	.2	23.4	6.81	1620	0.77	-29	5.9	13.67
1506		↓	23.6	6.82	1640	0.63	-26	7.8	13.66
1512		↓	23.6	6.81	1650	0.62	-26	7.4	13.66

Water Level (ft. BMP) at End of Purge: 13.66

Sample Intake Depth (ft. BMP):

SAMPLE INVENTORY

Time	Bottles Collected			Filtration (Y/N)	Preservation	Remarks (quality control sample, other)
	Volume	Composition (G, P)	No.			
1530	250ML	P	1	N	-	GEN CHEM
1530	500ML	P	1	N	HNO3	METALS

Comments:

Pastor, Behling & Wheeler, LLC
 2201 Double Creek Dr., Suite 4004
 Round Rock, TX 78664
 (512) 671-3434 Fax (512) 671-3446

LUMINANT



golder.com

**APPENDIX F7 – SEMI-ANNUAL REMEDY SELECTION PROGRESS REPORTS
(MARCH 4, 2020 AND SEPTEMBER 3, 2020)**



March 4, 2020

**SEMIANNUAL REMEDY SELECTION PROGRESS REPORT
MARTIN LAKE STEAM ELECTRIC STATION – ASH POND AREA**

In accordance with Title 40 Code of Federal Regulations (C.F.R.) § 257.97(a), the owner or operator of a coal combustion residuals (CCR) unit must prepare a semiannual report describing the progress in selecting and designing a remedy for statistically significant levels (SSLs) of constituents listed in Appendix IV of 40 C.F.R. Part 257 over the groundwater protection standards established in accordance with 40 C.F.R. § 257.95(h).

This report is for the Ash Pond Area at the Martin Lake Steam Electric Station.

As stated in the notifications dated February 6, 2019 and October 7, 2019, SSLs for beryllium and cobalt were identified at the Ash Pond Area during assessment monitoring completed in accordance with 40 C.F.R. § 257.95.

In response to the SSLs, an Assessment of Corrective Measures (ACM) report was completed for the Ash Pond Area in September 2019 as required by 40 C.F.R. § 257.96. The ACM report evaluated retrofitting the Ash Ponds liner systems for purposes of source control. Further evaluation of monitored natural attenuation, groundwater extraction and treatment or a vertical hydraulic barrier is ongoing for purposes of selecting a remedy under 40 C.F.R. § 257.97

A public meeting was held on November 13, 2019 at the Henderson Chamber of Commerce in Henderson, Texas to discuss the results of the of the ACM in accordance with 40 C.F.R. § 257.96(e).

Design of the Ash Pond liner system is in progress and the Retrofit Plan has been posted to the Operating Record. Selection of the groundwater remedy for the Ash Pond Area is currently in the feasibility study phase.



September 3, 2020

SEMI-ANNUAL REMEDY SELECTION PROGRESS REPORT MARTIN LAKE STEAM ELECTRIC STATION – ASH POND AREA

In accordance with Title 40 Code of Federal Regulations (C.F.R.) § 257.97(a), the owner or operator of a coal combustion residuals (CCR) unit must prepare a semiannual report describing the progress in selecting and designing a remedy for statistically significant levels (SSLs) of constituents listed in Appendix IV of 40 C.F.R. Part 257 over the groundwater protection standards established in accordance with 40 C.F.R. § 257.95(h).

This report is for the Ash Pond Area at the Martin Lake Steam Electric Station.

As stated in the notification dated February 6, 2019, SSLs for beryllium, cobalt and lithium were identified at the Ash Ponds during 2018 assessment monitoring completed in accordance with 40 C.F.R. § 257.95. However, no SSLs for lithium were identified in subsequent semi-annual assessment monitoring events completed in 2019 and 2020. As stated in the notifications dated October 7, 2019, February 7, 2020 and August 21, 2020, SSLs for beryllium and cobalt were identified at the Ash Pond Area during 2019 and 2020 assessment monitoring completed in accordance with 40 C.F.R. § 257.95.

In response to the SSLs, an Assessment of Corrective Measures (ACM) report was completed for the Ash Pond Area in September 2019 as required by 40 C.F.R. § 257.96. The ACM report concluded that the source control remedy would be retrofitting the liner system in the Ash Ponds and the groundwater remedy would be monitored natural attenuation (MNA), groundwater extraction and treatment or a vertical hydraulic barrier.

A public meeting was held on November 13, 2019 at the Henderson Chamber of Commerce in Henderson, Texas to discuss the results of the of the ACM in accordance with 40 C.F.R. § 257.96(e).

A notification of intent to retrofit the Ash Pond Area liner system was posted on June 29, 2020. Design of the Ash Pond Area liner system retrofit has been completed and construction is underway.

A feasibility study to evaluate MNA as a potential groundwater remedy for the Ash Pond Area is currently being performed. Feasibility study activities completed since March 4, 2020 include collection of additional groundwater samples to supplement previous soil and groundwater data and development of site-specific geochemical and groundwater models in order to understand the natural attenuation mechanisms occurring at the Ash Pond Area and evaluate the effectiveness of natural attenuation in meeting applicable groundwater protection standards.

APPENDIX F8 – STRUCTURAL STABILITY ASSESSMENT



REPORT

STRUCTURAL STABILITY ASSESSMENT REPORT

Martin Lake Steam Electric Station

Submitted To: Luminant
1601 Bryan Street
Dallas, TX 75201

Submitted By: Golder Associates Inc.
500 Century Plaza Drive, Suite 190
Houston, TX 77073 USA



Professional Engineering Firm
Registration Number F-2578

October 2016

Project No. 164816402





Table of Contents

- 1.0 INTRODUCTION..... 1
 - 1.1 Purpose 1
 - 1.2 Site Background..... 1
 - 1.2.1 The Bottom Ash Ponds (BAPs)..... 1
 - 1.2.2 New Scrubber Pond (NSP) 1
 - 1.2.3 Permanent Disposal Pond-5 (PDP-5)..... 2
 - 1.3 Previous Slope Stability Evaluations..... 2
- 2.0 SUBSURFACE CONDITIONS..... 3
 - 2.1 Site Geology..... 3
 - 2.1.1 Bottom Ash Ponds and Scrubber Pond 3
 - 2.1.1.1 Subsurface Investigations and Laboratory Testing..... 3
 - 2.1.1.2 Subsurface Site Conditions..... 4
 - 2.1.2 Permanent Disposal Pond - 5..... 4
 - 2.1.2.1 Subsurface Investigations and Laboratory Testing..... 4
- 3.0 STRUCTURAL STABILITY ASSESSMENT - §257.73(d)(1)(i)-(vii)..... 6
 - 3.1 Foundations and Abutments - §257.73(d)(1)(i)..... 6
 - 3.2 Slope Protection - §257.73(d)(1)(ii)..... 6
 - 3.3 Dikes (Embankment) - §257.73(d)(1)(iii)..... 6
 - 3.3.1 Bottom Ash Ponds and Scrubber Pond 6
 - 3.3.2 Permanent Disposal Pond – 5 7
 - 3.4 Vegetated Slopes - §257.73(d)(1)(iv)..... 7
 - 3.5 Spillways - §257.73(d)(1)(v)..... 7
 - 3.6 Hydraulic Structures - §257.73(d)(1)(vi)..... 7
 - 3.7 Downstream Slopes Adjacent to Water Body - §257.73(d)(1)(vii) 8
 - 3.8 Structural Stability Deficiencies - §257.73(d)(2)..... 8
- 4.0 CONCLUSION 9
- 5.0 CERTIFICATION..... 10
- 6.0 REFERENCES..... 11

List of Figures

Figure 1 General Site Map

List of Appendices

Appendix A Boring Location Map & Boring Logs
 Appendix B Laboratory Test Results





1.0 INTRODUCTION

1.1 Purpose

The “Disposal of Coal Combustion Residuals (CCR) from Electric Utilities rule” (40 Code of Federal Regulations (40 CFR) Part 257), effective October 19, 2015, requires that existing CCR surface impoundments meeting the requirements of §257.73(b) conduct initial and periodic structural stability assessments in accordance with §257.73(d). This report provides the structural stability assessment for the Martin Lake Steam Electric Station’s (MLSES’s) CCR Impoundments, identified as the Bottom Ash Ponds (BAPs) – the West Ash Pond (WAP) and the East Ash Pond (EAP) – the New Scrubber Pond (NSP), and the Permanent Disposal Pond-5 (PDP-5).

1.2 Site Background

The MLSES generates bottom ash, fly ash, and flue gas desulfurization (FGD) material during electricity generation. The following surface impoundments, shown on Figure 1, are in operation at the MLSES and subject to the CCR rule.

1.2.1 The Bottom Ash Ponds (BAPs)

The BAPs include the West Ash Pond (WAP) and the East Ash Pond (EAP). The WAP and EAP receive sluice water from bottom ash dewatering bins and other process wastewater sources that typically include bottom ash fines. The BAPs were originally constructed in 1977 with a 2-foot thick compacted clay liner. In 1989, the WAP was relined with a 60-mil high density polyethylene (HDPE) geomembrane over 3 feet of clay on the sideslopes, and the floor with a double 60-mil HDPE geomembrane with a geonet leak detection layer overlying an 18-inch thick clay liner. Both the sideslopes and floor are overlain with a 4-inch thick concrete revetment mat. In 2010 the sideslopes and floor of the EAP were relined with a double 60-mil HDPE geomembrane with a geonet leak detection layer overlying an 18-inch thick clay layer. A geotextile layer was placed between the lower geomembrane and the clay. The liner system on the sideslopes and floor of the EAP are overlain with a 4-inch thick concrete revetment mat.

1.2.2 New Scrubber Pond (NSP)

The NSP, abutting the southeastern portion of the WAP and the southern portion of the EAP, is used to manage FGD wastes and discharge from the sludge thickener sumps, the plant yard sumps, and stormwater management areas. Water collecting in the NSP serves as wet-well make-up water as well as emergency make-up water in the scrubber area. The NSP was originally constructed with the BAPs and lined with clay liner. In 1989, the NSP was relined with a double 60-mil HDPE geomembrane with a geonet leak detection layer. A geotextile layer was placed between the lower geomembrane and the subgrade and a 4-inch thick concrete revetment mat covers the upper geomembrane.



1.2.3 Permanent Disposal Pond-5 (PDP-5)

PDP-5 is primarily used to manage excess liquids including stormwater and excess process wastewater from both the New Scrubber Pond and Bottom Ash Ponds. Recovered CCR wastewaters are received in PDP-5 during cleaning cycles. PDP-5 was constructed in 2010/2011, above PDP-1, PDP-2, and PDP-3, which were previously closed as landfills. PDP-5 is lined with a 3-foot thick clay liner on the sideslopes and a 2-foot thick clay liner on the floor, both overlain with a 0.5-foot thick protective cover soil layer.

1.3 Previous Slope Stability Evaluations

Golder and E TTL Engineers and Consultants (E TTL) have previously performed evaluations on the BAPs, the NSP and PDP-5 as part of the following reports submitted to Luminant:

- Ash and Scrubber Ponds and Permanent Disposal Pond #4, Stability Investigation Report, Luminant Martin Lake SES, Rusk County, Texas, Golder, dated December 2012.
- Geotechnical Investigation, Luminant Martin Lake SES, Reline East Ash Disposal Pond, Tatum, Texas, E TTL, dated December 2008.

The studies found the BAPs and NSP slopes to be adequately stable.

E TTL performed stability evaluations on PDP-5 in 2009, as presented in the following report:

- Geotechnical Investigation, Luminant Martin Lake SES, Vertical Expansion of Permanent Disposal Ponds 1, 2, and 3, Tatum, Texas. E TTL Engineers and Consultants Inc. Tyler, Texas, dated July 2008.
- Geotechnical Investigation, Luminant Martin Lake SES, Vertical Expansion of Permanent Disposal Ponds 1, 2, and 3, Tatum, Texas – Supplemental Seepage and Slope Stability. E TTL Engineers and Consultants Inc., dated October 2009.

The above reports found the design slopes of PDP-5 to be stable as long as drainage is functional, preventing the embankments from saturating.



2.0 SUBSURFACE CONDITIONS

The MLSES site is located in the Martin Creek area which is situated in the Sabine River Valley and lies on the west flank of the Sabine Uplift. The formations in the region comprise sedimentary deposits of continental and marine origin, mainly the lower Wilcox Group flanked by younger beds like the Carrizo Sand. In the Martin Creek area, the Wilcox formation is estimated to be about 650- to 700-feet thick and consists of sandy clays, silty sands, clays, and lignite in varying amounts. The Rockdale formation is the major component in the area among the sediments of the Wilcox group occupying approximately the middle four-fifths of the Wilcox Section. The Wilcox Group is underlain by the Paleocene Midway Group (containing Upper Willis and Lower Kincaid), which is estimated to be 900-feet thick around the site, and is composed mainly of silty clay and clay. The Midway Group overlies a section of Cretaceous Rocks that are approximately 7000-feet thick (Rone Engineers, 1984).

2.1 Site Geology

2.1.1 Bottom Ash Ponds and Scrubber Pond

2.1.1.1 Subsurface Investigations and Laboratory Testing

Information from previous subsurface investigations was used to characterize the subsurface site conditions. In 2008, E TTL conducted a subsurface investigation for the EAP as part of an effort to reline the pond. E TTL drilled twelve borings along the crest of the EAP embankment at approximate elevation 330 feet – mean sea level (ft-msl). All borings were 40-feet deep except one which was 100-feet deep. The boring map and boring logs are presented in Appendix A. Geotechnical laboratory testing – moisture contents, Atterberg limits, grain size distribution, and consolidated-undrained (CU) triaxial compression tests - was conducted on selected samples. The soil index testing results presented as part of the boring logs, while the CU test results from E TTL are summarized in Appendix B.

Golder conducted a subsurface investigation for the WAP and NSP in December 2012. Golder completed eight, 50- to 60-foot deep borings along the crest of the pond embankments at approximate elevation 330 ft-msl. The boring map and boring logs are presented in Appendix A. As part of the investigation, laboratory testing was performed on selected samples in accordance with commonly accepted methods and practices. Undisturbed and disturbed soil samples were tested to determine water content, Atterberg limits, grain size distribution, and shear strength. Water content determination was performed in accordance with ASTM D2216; Atterberg limits were determined in accordance with ASTM D4318; and grain size distribution was performed in accordance with ASTM D422. Shear strength testing consisted of unconsolidated-undrained (UU) triaxial compression in general accordance with ASTM D2850. Laboratory test results are presented in Appendix B.



The findings from the above subsurface investigations were reviewed for their applicability to this study, and are summarized in the following sections.

2.1.1.2 Subsurface Site Conditions

The above borings consisted of fill and native soils. The soils encountered in the borings generally consisted of stiff to hard sandy clays and firm to very dense sands. The subsurface stratigraphy generally consisted of interchanging layers of clays, sandy clays, clayey sands and non-plastic sands. The clayey sand layers ranged in thickness from 2 to 16 feet where encountered. The sandy clay and clay layers are described as firm to hard, low to high plasticity clays and vary in thickness from 2 to 38 feet. Loose to very dense, silty or poorly graded sand was typically encountered beneath or interlayered with the sandy clay/clayey sand strata. The 100-foot boring by E TTL showed deeper layers of very dense silty sand with intermittent layers of hard low plasticity clay.

Water was encountered in each of the eight borings performed by Golder, ranging between El. 296.1 to 303.3 ft-msl. The average water elevation measured in the Golder boreholes, during drilling, was at El. 300.3 ft-msl. The E TTL borings measured the water level to range between El. 304 to 309 ft-msl, with an average water level of El. 306 ft-msl, coinciding with the normal pool elevation of the adjacent Martin Lake (a man-made reservoir).

Groundwater levels measured in 2015, from wells surrounding the BAPs, varied from approximately El. 304 ft-msl in the southeast corner to El. 307 ft-msl in the northwest corner.

2.1.2 Permanent Disposal Pond - 5

2.1.2.1 Subsurface Investigations and Laboratory Testing

In 2008, E TTL performed a pre-construction subsurface investigation for PDP-5 that included a total of eleven borings within the PDP-5 footprint. In addition, three cone penetrometer tests (CPTs) were performed. As part of a supplemental investigation in 2009, E TTL drilled a further three borings within the pond footprint. The map of the borings, and boring and CPT logs are presented in Appendix A.

E TTL performed laboratory tests including natural moisture contents (ASTM D2216), Atterberg limits (ASTM D4318), particle size distributions (ASTM D 1140 and ASTM D422). Unconsolidated-undrained (UU) triaxial compression tests (ASTM D2850) were performed to determine the strength characteristics of cohesive substrata. Direct shear tests (ASTM D3080) were performed on coarser materials including remolded bulk ash samples. Consolidation tests (ASTM D2435) and permeability tests (ASTM D5084) were also performed but are not relevant to the current study. The results of the laboratory tests performed by E TTL are presented in Appendix B.



2.1.2.2 Subsurface Site Conditions

Most of the above borings were drilled through the bottom ash within closed PDP-1, 2, and 3. Based on particle size, the ash classifies as very loose to medium dense poorly graded sands in some locations, to silts in other locations and depths. The borings passing through existing embankments of PDP-1, 2, and 3 contained medium stiff to very stiff clay of low plasticity and/or high plasticity clay with clayey sand. Native soils were identified in deeper borings as very dense silt with hard low plasticity clay seams.

Two borings located outside of the ash encountered groundwater approximately between El. 355 to 368 ft-msl. Groundwater levels measured in 2015, from wells surrounding PDP-5, indicate that the groundwater level varies from approximately El. 355 ft-msl in the north to El. 375 ft-msl in the south.

LUMINANT



3.0 STRUCTURAL STABILITY ASSESSMENT - §257.73(d)(1)(i)-(vii)

The CCR rules require conducting periodic structural stability assessments by a qualified professional engineer to document whether the design, construction, operation and maintenance is consistent with recognized and generally accepted good engineering practices for the maximum volume of CCR and CCR wastewater that can be impounded therein.

3.1 Foundations and Abutments - §257.73(d)(1)(i)

As noted above, the foundation soils for the BAPs and NSP generally consist of stiff to hard sandy clays and compact to dense sand. As discussed below, the embankment fill appears to be well-compacted. The foundation soils and abutments of the BAPs and NSP are stable.

Parts of the foundation soils for PDP-5 embankments are founded on the existing bottom ash of underlying PDP-1, 2, and 3 which were previously closed as landfills. Based on particle size, the bottom ash classifies as very loose to medium dense, poorly graded sand at some locations and silts at other locations and depths. Based on the above mentioned ETTL reports and the preparation of foundation materials during construction, the foundations and abutments are generally considered to be stable. The possibility of liquefaction of bottom ash in the foundation is considered in the Safety Factor Assessment report (Golder, 2016).

3.2 Slope Protection - §257.73(d)(1)(ii)

The downstream slopes of the BAPs, NSP and PDP-5 embankments are protected from erosion and deterioration by the establishment of a vegetative cover. Portions of the EAP and the NSP adjacent to Martin Lake are protected from wave action with roller compacted concrete. The vegetative cover is inspected weekly for erosion, signs of seepage, animal burrows, sloughing, and plants that could negatively impact the embankment. For the BAPs and NSP, the interior slopes are protected from wave action by concrete revetment mats or riprap. The interior slopes of PDP-5 are covered with vegetative cover for erosion protection.

3.3 Dikes (Embankment) - §257.73(d)(1)(iii)

3.3.1 Bottom Ash Ponds and Scrubber Pond

No construction documentation or testing details of the original BAPs and NSP embankment fills are available. Based on the borings, the embankments were constructed using a clayey fill likely from an on-site borrow source. Golder's subsurface investigation of 2012 and ETTL's investigation of the EAP in 2008 comprised boreholes drilled into the embankment. These borings found the embankment soils to generally consist of stiff to hard sandy clay, clayey sand, and clay, consistent with well-compacted fill. No significant repairs have been performed to the BAPs and NSP embankments since their initial construction, except the relining of the WAP and NSP in 1989, and the relining of the EAP in 2010. Based on a review of past



inspection reports and on recent observations, the BAPs and NSP embankments are sufficient to withstand the range of loading conditions they are subjected to.

3.3.2 Permanent Disposal Pond – 5

PDP-5 was constructed with on-site soils in 2010/2011. A 3-foot thick clay layer was placed over PDP-1, PDP-2 and PDP-3, beneath the new PDP-5 embankment. Sections of the embankment overlie the bottom ash from the closed ponds.

The clay liner was specified to be installed and compacted in 6-inch lifts, to at least 95% Standard Proctor maximum dry density at optimum moisture content to 4% above. The embankment was specified to be constructed in loose lifts of 8-inch maximum thickness, followed by compaction to 95% standard Proctor maximum dry density.

Based on a review of past inspection reports and on recent observations, each of the embankments are sufficient to withstand the range of loading conditions they are subjected to.

3.4 Vegetated Slopes - §257.73(d)(1)(iv)

As of June 14, 2016 the US Court of Appeals for the District of Columbia Circuit issued an Order that remanded and vacated the CCR rule requirement that vegetation on the exterior portions of dikes on CCR surface impoundments be maintained not to exceed six inches in height. EPA will issue a new rulemaking in the future to address this issue.

Each of the surface impoundments at the MLSES are inspected weekly. Luminant maintains the vegetation in a manner that ensures adequate inspections can be conducted.

3.5 Spillways - §257.73(d)(1)(v)

There are no spillways on any of the surface impoundments.

3.6 Hydraulic Structures - §257.73(d)(1)(vi)

The only subsurface penetrations in the BAPs and NSP are 24-inch dewatering lines that pass through the WAP and the NSP embankments, which are used for decanting process wastewater from within the ponds. These dewatering lines connect to a collection sump at the low pressure ash water pump station located to the south of the NSP. All other piping passes above the crest of the embankments.

According to as-built drawings prepared by HDR Engineering, Inc., a 14-inch diameter HDPE overflow pipe, encased in a 20-inch diameter HDPE pipe passes through the southern embankment. Flow through this pipe is controlled with a valve located near the toe of the embankment. Discharge from PDP-5 is accomplished using a submersible pump suspended from a pump platform adjacent to the overflow pipe along the southern embankment. All other piping passes above the crest of the embankment.



No significant deterioration, deformation, distortion, bedding deficiencies, sedimentation, or debris were observed that may negatively affect the operation of the surface impoundments.

3.7 Downstream Slopes Adjacent to Water Body - §257.73(d)(1)(vii)

The east slope of the EAP and the south slope of the NSP are adjacent to Martin Lake. The normal pool elevation of Martin Lake is at El. 306 ft-msl. This water level is relatively shallow against the exterior slope. Moreover, the exterior slopes of both the east side of the EAP and the south side of the NSP are lined with roller compacted concrete to protect these slopes from erosion, as well as seepage. Nevertheless, the impact of drawdown of Martin Lake on the stability of the BAP and NSP embankments is considered in the Safety Factor Assessment report (Golder, 2016). The results of stability analysis indicate that the factor of safety for rapid drawdown conditions is approximately 1.6, which exceeds the typically required value of 1.30.

3.8 Structural Stability Deficiencies - §257.73(d)(2)

No structural stability deficiencies were identified during this assessment.

LUMINANT



4.0 CONCLUSION

Based on our review of the information provided by Luminant, on information prepared by Golder Associates Inc., and on our on-site observations, no structural stability deficiencies were identified in the surface impoundments during this assessment.

Golder appreciates the opportunity to assist Luminant with this project. If you have any questions, or require further assistance from Golder, please contact the undersigned at (281) 821-6868.

GOLDER ASSOCIATES INC.

Varenya Kumar
Staff Engineer

VK/JBF/kc

Jeffrey B. Fassett, PE
Associate Geotechnical Engineer

LUMINANT



5.0 CERTIFICATION

I hereby certify that this report has been prepared in general accordance with normally accepted civil engineering practices and in accordance with the requirements of 40 CFR 257.73(d).



Jeffrey B. Fassett, PE
Golder Associates Inc.
Firm Registration Number F-2578

LUMINANT



6.0 REFERENCES

ETTL Engineers and Consultants Inc. 2008. Geotechnical Investigation, Luminant Martin Lake SES, Vertical Expansion of Permanent Disposal Ponds 1, 2, and 3, Tatum, Texas.

ETTL Engineers and Consultants Inc. 2009. Geotechnical Investigation, Luminant Martin Lake SES, Vertical Expansion of Permanent Disposal Ponds 1, 2, and 3, Tatum, Texas – Supplemental Seepage.

Golder Associates Inc. 2012. Ash and Scrubber Ponds and Permanent Disposal Pond #4 – Stability Investigation Report, Luminant Martin Lake Power Plant, Rusk County, Texas.

Golder Associates Inc. 2016. Safety Factor Assessment Report, Luminant Martin Lake Steam Electric Station.

HDR Engineering Inc. 2011. Martin Lake Steam Electric Station, Rusk County, Texas – Permanent Disposal Pond #5 – As Recorded Drawings.

Pastor, Behling & Wheeler Inc. 2016. Annual CCR Inspection Report. Luminant Martin Lake Steam Electric Station, Ash Pond Area, Permanent Disposal Pond No. 5 & A1 Area Landfill, Rusk & Panola County, Texas

LUMINANT



REFERENCE(S)
AERIAL PHOTO SOURCED FROM GOOGLE EARTH PRO DATED: 2015-10-01

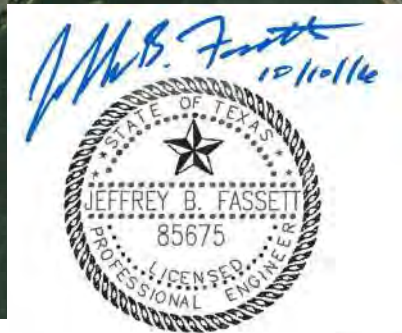

Professional Engineering Firm
Registration Number F-2578



CLIENT
**LUMINANT POWER
MARTIN LAKE**

PROJECT
**2016 COAL COMBUSTION RESIDUALS
ENGINEERING SERVICES**

CONSULTANT	YYYY-MM-DD	2016-09-22
	PREPARED	VK
	DESIGNED	TNB
	REVIEWED	MX
	APPROVED	JBF



TITLE
GENERAL SITE MAP

PROJECT NO.
164816402

REV.

FIGURE
1

APPENDIX A
BORING LOCATION MAP & BORING LOGS

BOTTOM ASH PONDS AND SCRUBBER POND

LUMIVANT

NOTE: Figure Reference - Golder Associates Inc. 2012. Ash and Scrubber Ponds and Permanent Disposal Pond #4 – Stability Investigation Report, Luminant Martin Lake Power Plant, Rusk County, Texas.



LEGEND

● BH-101 BORING LOCATION

REFERENCE

1.) AERIAL SHOWN LICENSED FROM GOOGLE EARTH PROFESSIONAL.

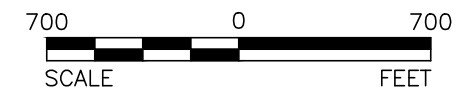

REV	DATE	DES	REVISION DESCRIPTION	CADD	CHK	RWW

PROJECT LUMINANT - MARTIN LAKE
ASH & SCRUBBER POND SLOPE STABILITY INVESTIGATION REPORT
RUSK COUNTY, TEXAS

TITLE

BORING LOCATIONS

		PROJECT No. 123-94128	FILE No. 12394128A003
DESIGN	MGP	12/04/12	SCALE AS SHOWN REV. 0
CADD	RG	12/04/12	FIGURE 1
CHECK	MGP	12/04/12	
REVIEW	PCM	12/04/12	

Drawing file: 12394128A003.dwg Dec 06, 2012 - 11:05am

© 2012 Google

Google™ earth



500 Century Plaza Drive, Suite 190
Houston, Texas 77073
Telephone: (281) 821-6868
Fax: (281) 821-6870

BORING NUMBER BH-201

PAGE 1 OF 2

CLIENT Luminant
PROJECT NUMBER 123-94128
DATE STARTED 10/28/12 COMPLETED 10/28/12
DRILLING CONTRACTOR WEST Drilling
DRILLING METHOD Hollow Stem Auger
LOGGED BY FW CHECKED BY MP
NOTES _____

PROJECT NAME Pond Slope Stability
PROJECT LOCATION Martin Lake
GROUND ELEVATION 330 ft HOLE SIZE 8 inches
GROUND WATER LEVELS:
▽ AT TIME OF DRILLING 28.30 ft / Elev 301.70 ft
AT END OF DRILLING ---
AFTER DRILLING ---

GEOTECH BH PLOTS - GINT STD US LAB.GDT - 12/4/12 15:58 - P.1 - 2012 PROJECT FOLDERS\123-94128 LUMINANT POND SLOPE STABILITY\MARTIN LAKE\LAB TESTING\94128\MARTINLAKE.GPJ

DEPTH (ft)	GRAPHIC LOG	MATERIAL DESCRIPTION	SAMPLE TYPE NUMBER	RECOVERY % (RQD)	BLOW COUNTS (N VALUE)	POCKET PEN. (tsf)	DRY UNIT WT. (pcf)	▲ SPT N VALUE ▲			
								PL	MC	LL	
								□ FINES CONTENT (%) □			
								20	40	60	80
0		Remove 8" sandy gravel as road base									
0-4		(CL) SILTY CLAY, low plasticity, some sand, trace gravels, red, dry, hard	SH 1	44		5.0					
4-5		(SC) CLAYEY SAND, non-plastic, some silt, tan and gray, dry, compact	SS 2	58	15-10-7 (17)						
5-6		(CL) SANDY CLAY, low plasticity, some silt, red, tan, and gray, mottled, dry, stiff	SH 3	44		3.5					
6-7		(SC) CLAYEY SAND, fine, subangular, non-plastic, little silt, tan and gray, mottled, dry	SH 4	38		1.5					
7-10		(CL) SANDY CLAY, low plasticity, little silt and gravel, red, tan, and gray, mottled, dry, hard	SH 5	42		4.5					
10-13		some silt, no gravel, very stiff at 13.0'									
13-15			SH 6	58		3.5					
15-18		some sand veins at 18.0'									
18-20			SH 7	38		3.0					
20-23		gray, moist at 23.0'									
23-25			SH 8	58		2.5					
25-30		(SC) CLAYEY SAND, fine, subangular, low plasticity, some to little silt	SH 9	71		2.0					
30-33		some silt, tan and gray, mottled, moist at 33.0'									
33-35			SS 10	100	9-7-9 (16)						

(Continued Next Page)



500 Century Plaza Drive, Suite 190
Houston, Texas 77073
Telephone: (281) 821-6868
Fax: (281) 821-6870

BORING NUMBER BH-201

CLIENT Luminant PROJECT NAME Pond Slope Stability
PROJECT NUMBER 123-94128 PROJECT LOCATION Martin Lake

DEPTH (ft)	GRAPHIC LOG	MATERIAL DESCRIPTION	SAMPLE TYPE NUMBER	RECOVERY % (RQD)	BLOW COUNTS (N VALUE)	POCKET PEN. (tsf)	DRY UNIT WT. (pcf)	▲ SPT N VALUE ▲	
								PL	MC LL
								□ FINES CONTENT (%) □	
								20	40 60 80
35									
40		some silty sand veins at 38.0'	SH 11	50		2.0		●	□
45		(SM) SILTY SAND, fine, subangular, non-plastic, little clay, tan and red, wet, compact	SS 12	100	11-11-11 (22)			●	
		(SP) SAND, medium to fine, subangular, poorly graded, some silt, tan, wet, compact	SS 13	100	5-9-11 (20)			▲	
50								●	

Bottom of borehole at 50.0 feet.

GEOTECH BH PLOTS - GINT STD US LAB.GDT - 12/4/12 15:58 - P.1_2012 PROJECT FOLDERS\123-94128 LUMINANT POND SLOPE STABILITY\MARTIN LAKE\LAB TESTING\94128\MARTINLAKE.GPJ

LUMINANT



500 Century Plaza Drive, Suite 190
Houston, Texas 77073
Telephone: (281) 821-6868
Fax: (281) 821-6870

BORING NUMBER BH-202

PAGE 1 OF 2

CLIENT Luminant
PROJECT NUMBER 123-94128
DATE STARTED 10/29/12 **COMPLETED** 10/29/12
DRILLING CONTRACTOR WEST Drilling
DRILLING METHOD Hollow Stem Auger
LOGGED BY FW **CHECKED BY** MP
NOTES _____

PROJECT NAME Pond Slope Stability
PROJECT LOCATION Martin Lake
GROUND ELEVATION 330 ft **HOLE SIZE** 8 inches
GROUND WATER LEVELS:
▽ **AT TIME OF DRILLING** 26.70 ft / Elev 303.30 ft
AT END OF DRILLING ---
AFTER DRILLING ---

DEPTH (ft)	GRAPHIC LOG	MATERIAL DESCRIPTION	SAMPLE TYPE NUMBER	RECOVERY % (RQD)	BLOW COUNTS (N VALUE)	POCKET PEN. (tsf)	DRY UNIT WT. (pcf)	▲ SPT N VALUE ▲			
								PL	MC	LL	
								□ FINES CONTENT (%) □			
								20	40	60	80
0		Remove 6" sandy gravel from road bed									
0-2		(CH) CLAY, medium to high plasticity, some silt, trace fine sand, tan and gray, dry, very stiff to hard some sand at 2.0'	SH 1	50		4.5					
2-3			SH 2	63		3.5					
3-4			SH 3	50		5.0					
4-5			SH 4	63		3.75					
5-10		(CL) SANDY CLAY, low plasticity, some to little silt, tan and gray, mottled, moist, firm	SH 5	42		4.0					
10-13		some sand seams, very stiff at 13.0'									
13-14			SH 6	42		3.0					
14-20		(CL) SILTY CLAY, medium to high plasticity, little fine sand, brown, moist, firm	SH 7	58		1.0					
20-23		low plasticity, gray, moist at 23.0'									
23-24			SH 8	71		5.0					
24-30											
30-31		(SM) SILTY SAND, fine, subangular, non-plastic, some clay, gray and tan, wet, compact	SS 9	83	7-7-9 (16)						
31-35		(SC) CLAYEY SAND, fine, subangular, low plasticity, some silt, tan and gray, wet, compact	SS 10	100	3-5-6 (11)						

(Continued Next Page)

GEOTECH BH PLOTS - GINT STD US LAB.GDT - 12/4/12 15:58 - P.1 - 2012 PROJECT FOLDERS\123-94128 LUMINANT POND SLOPE STABILITY\MARTIN LAKE\LAB TESTING\94128\MARTINLAKE.GPJ



500 Century Plaza Drive, Suite 190
 Houston, Texas 77073
 Telephone: (281) 821-6868
 Fax: (281) 821-6870

BORING NUMBER BH-202

CLIENT Luminant PROJECT NAME Pond Slope Stability
 PROJECT NUMBER 123-94128 PROJECT LOCATION Martin Lake

DEPTH (ft)	GRAPHIC LOG	MATERIAL DESCRIPTION	SAMPLE TYPE NUMBER	RECOVERY % (RQD)	BLOW COUNTS (N VALUE)	POCKET PEN. (tsf)	DRY UNIT WT. (pcf)	▲ SPT N VALUE ▲	
								PL	MC LL
								□ FINES CONTENT (%) □	
								20	40 60 80
35									
40		interbedded clay and sand seams at 38.0'	SS 11	100	8-7-8 (15)			▲ ●	
45		no seams at 43.0'	SS 12	89	4-4-4 (8)			▲ ●	
50		(SP) SAND, medium to fine, poorly graded, subangular, non-plastic, some silt and clay, wet, loose	SS 13	100	2-3-4 (7)			▲ ●	

Bottom of borehole at 50.0 feet.

GEOTECH BH PLOTS - GINT STD US LAB.GDT - 12/4/12 15:58 - P.1_2012 PROJECT FOLDERS\123-94128 LUMINANT POND SLOPE STABILITY\MARTIN LAKE\LAB TESTING\94128\MARTINLAKE.GPJ

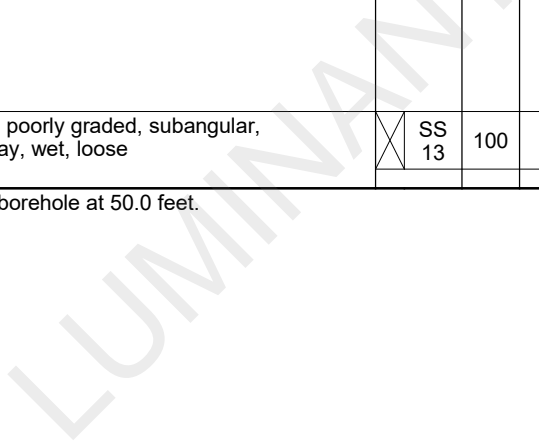



500 Century Plaza Drive, Suite 190
Houston, Texas 77073
Telephone: (281) 821-6868
Fax: (281) 821-6870

BORING NUMBER BH-203

CLIENT Luminant
PROJECT NUMBER 123-94128
DATE STARTED 10/30/12 **COMPLETED** 10/30/12
DRILLING CONTRACTOR WEST Drilling
DRILLING METHOD Hollow Stem Auger
LOGGED BY FW **CHECKED BY** MP
NOTES _____

PROJECT NAME Pond Slope Stability
PROJECT LOCATION Martin Lake
GROUND ELEVATION 330 ft **HOLE SIZE** 8 inches
GROUND WATER LEVELS:
 ▽ **AT TIME OF DRILLING** 28.80 ft / Elev 301.20 ft
AT END OF DRILLING ---
AFTER DRILLING ---

DEPTH (ft)	GRAPHIC LOG	MATERIAL DESCRIPTION	SAMPLE TYPE NUMBER	RECOVERY % (RQD)	BLOW COUNTS (N VALUE)	POCKET PEN. (tsf)	DRY UNIT WT. (pcf)	▲ SPT N VALUE ▲		
								PL	MC	LL
								□ FINES CONTENT (%) □		
0		remove 14" sandy GRAVEL as roadbed								
1		(CL) SILTY CLAY, low plasticity, little sand, gray and tan, mottled, dry, very stiff	SH 1	44		2.75		●		
2		(CL) SANDY CLAY, low plasticity, some silt, gray and tan, mottled, dry, stiff	SH 2	50		1.5		●		
3		low plasticity, some sand veins, soft	SH 3	42		1.25		●		
4		(CL-CH) CLAY, low plasticity to medium plasticity, some silt, dark to light gray, dry, stiff	SH 4	67		1.75		●	—	
5		very stiff at 8.0'	SH 5	50		3.25		●		
10										
15		low plasticity, some silt and fine sand, little coarse sand and fine gravels, subrounded, red and tan, stiff at 13.0'	SH 6	38		1.5		●		
20		(CL) SANDY CLAY, low plasticity, some silt, tan and gray, mottled, dry, stiff	SH 7	44		2.0		●		
25		(SC) CLAYEY SAND, low plasticity, some silt, tan and gray, mottled, compact, moist	SS 8	94	3-7-7 (14)			●		
28.80	▽	low plasticity, with grey silty clay, some sand, tan at 28.0'	SS 9	94	4-7-8 (15)			●	▲	
35		(SM) SILTY SAND, non-plastic, grading to sand, some silt, little to trace clay, gray, wet, compact	SS 10	100	3-8-9 (17)			●	▲	

(Continued Next Page)

GEO TECH BH PLOTS - GINT STD US LAB.GDT - 12/4/12 15:58 - P.1 - 2012 PROJECT FOLDERS\123-94128 LUMINANT POND SLOPE STABILITY\MARTIN LAKE\LAB TESTING\94128\MARTINLAKE.GPJ



500 Century Plaza Drive, Suite 190
Houston, Texas 77073
Telephone: (281) 821-6868
Fax: (281) 821-6870

BORING NUMBER BH-203

CLIENT Luminant PROJECT NAME Pond Slope Stability

PROJECT NUMBER 123-94128 PROJECT LOCATION Martin Lake

DEPTH (ft)	GRAPHIC LOG	MATERIAL DESCRIPTION	SAMPLE TYPE NUMBER	RECOVERY % (RQD)	BLOW COUNTS (N VALUE)	POCKET PEN. (tsf)	DRY UNIT WT. (pcf)	▲ SPT N VALUE ▲	
								PL	MC LL
								□ FINES CONTENT (%) □	
								20 40 60 80	
35									
40		some clay and silt veins, tan at 38.0'	SS 11	100	3-6-6 (12)			▲	●
45		(SC) CLAYEY SAND, low plasticity, some silt, tan and brown, wet, compact	SS 12	100	4-8-10 (18)			▲	
50		(SM) SILTY SAND, non-plastic, trace clay, tan and gray, wet, dense	SS 13	100	8-14-20 (34)				▲

Bottom of borehole at 50.0 feet.

GEOTECH BH PLOTS - GINT STD US LAB.GDT - 12/4/12 15:58 - P.1_2012 PROJECT FOLDERS\123-94128 LUMINANT POND SLOPE STABILITY\MARTIN LAKE\LAB TESTING\94128\MARTINLAKE.GPJ

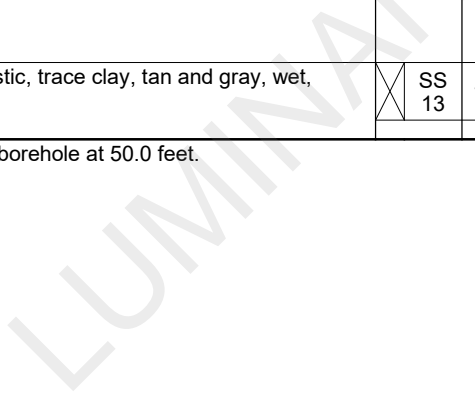



500 Century Plaza Drive, Suite 190
Houston, Texas 77073
Telephone: (281) 821-6868
Fax: (281) 821-6870

BORING NUMBER BH-204

CLIENT Luminant
PROJECT NUMBER 123-94128
DATE STARTED 10/30/12 **COMPLETED** 10/30/12
DRILLING CONTRACTOR WEST Drilling
DRILLING METHOD Hollow Stem Auger
LOGGED BY FW **CHECKED BY** MP
NOTES _____

PROJECT NAME Pond Slope Stability
PROJECT LOCATION Martin Lake
GROUND ELEVATION 330 ft **HOLE SIZE** 8 inches
GROUND WATER LEVELS:
▽ **AT TIME OF DRILLING** 31.80 ft / Elev 298.20 ft
AT END OF DRILLING ---
AFTER DRILLING ---

GEOTECH BH PLOTS - GINT STD US LAB.GDT - 12/4/12 15:58 - P.1 - 2012 PROJECT FOLDERS\123-94128 LUMINANT POND SLOPE STABILITY\MARTIN LAKE\LAB TESTING\94128\MARTINLAKE.GPJ

DEPTH (ft)	GRAPHIC LOG	MATERIAL DESCRIPTION	SAMPLE TYPE NUMBER	RECOVERY % (RQD)	BLOW COUNTS (N VALUE)	POCKET PEN. (tsf)	DRY UNIT WT. (pcf)	▲ SPT N VALUE ▲			
								PL	MC	LL	
								□ FINES CONTENT (%) □			
								20	40	60	80
0		removed SANDY GRAVEL from roadbed									
1		(CL) SILTY CLAY, low plasticity, some sand, tan and gray, mottled, dry, hard	SH 1	67		4.25		●			
2		(CL) LEAN CLAY, low plasticity, some silt, sand, and sand veins, red and gray, dry, very stiff	SH 2	50		3.0		●			
3		(SC) CLAYEY SAND, low plasticity, some silt and black sandy gravel veins, tan and gray, dry	SH 3	33		5.0		●			
4		(CL) SANDY CLAY, low plasticity, little silt, tan and gray, dry, stiff	SH 4	58		2.0		●			
5		(SC) CLAYEY SAND, non-plastic to low plasticity, little silty clay seam, tan, brown, with little gray, dry	SH 5	44		2.5		●			
10		(CL) LEAN CLAY, low to medium plasticity, some silt, trace fine sand, tan, brown, and gray, mottled, dry, stiff	SH 6	67		2.0					
15		some sand, little silt	SH 7	67		1.5					
20		(CL) SANDY CLAY, low plasticity, little silt, tan and gray, moist, very stiff	SH 8	46		3.0					
25		(ML) SANDY SILT, low plasticity to non-plastic, fine, subangular, some clay, tan and gray, moist, soft	SS 9	100	2-1-3 (4)			▲ ● □			
30	▽	(SM) SILTY SAND, low plasticity to non-plastic, fine, subangular, gray with little brown, dense	SS 10	94	11-14-18 (32)			● ▲			
35											

(Continued Next Page)



500 Century Plaza Drive, Suite 190
Houston, Texas 77073
Telephone: (281) 821-6868
Fax: (281) 821-6870

BORING NUMBER BH-204

CLIENT Luminant PROJECT NAME Pond Slope Stability
PROJECT NUMBER 123-94128 PROJECT LOCATION Martin Lake

DEPTH (ft)	GRAPHIC LOG	MATERIAL DESCRIPTION	SAMPLE TYPE NUMBER	RECOVERY % (RQD)	BLOW COUNTS (N VALUE)	POCKET PEN. (tsf)	DRY UNIT WT. (pcf)	▲ SPT N VALUE ▲		
								20	40	60
								PL MC LL 20 40 60 80		
								<input type="checkbox"/> FINES CONTENT (%) <input type="checkbox"/> 20 40 60 80		
35										
40		(SC) CLAYEY SAND, fine, subangular, interbedded with gray, silty sand, some clay, tan, wet, compact	SS 11	94	4-5-6 (11)				▲	●
45		(CH) CLAY, medium plasticity, little silt, trace fine sand, gray, wet, stiff	SS 12	100	3-5-7 (12)				▲	●
50			SH 13	75		2.0				●

Bottom of borehole at 50.0 feet.

GEOTECH BH PLOTS - GINT STD US LAB.GDT - 12/4/12 15:58 - P.1_2012 PROJECT FOLDERS\123-94128 LUMINANT POND SLOPE STABILITY\MARTIN LAKE\LAB TESTING\94128\MARTINLAKE.GPJ

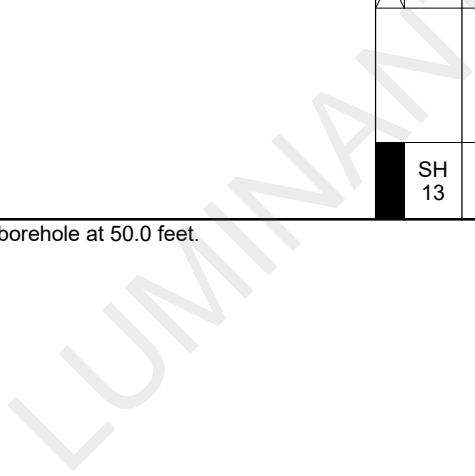



500 Century Plaza Drive, Suite 190
Houston, Texas 77073
Telephone: (281) 821-6868
Fax: (281) 821-6870

BORING NUMBER BH-205

PAGE 1 OF 2

CLIENT Luminant
PROJECT NUMBER 123-94128
DATE STARTED 10/30/12 **COMPLETED** 10/30/12
DRILLING CONTRACTOR WEST Drilling
DRILLING METHOD Hollow Stem Auger
LOGGED BY FW **CHECKED BY** MP
NOTES _____

PROJECT NAME Pond Slope Stability
PROJECT LOCATION Martin Lake
GROUND ELEVATION 330.5 ft **HOLE SIZE** 8 inches
GROUND WATER LEVELS:
▽ **AT TIME OF DRILLING** 29.40 ft / Elev 301.10 ft
AT END OF DRILLING ---
AFTER DRILLING ---

GEO TECH BH PLOTS - GINT STD US LAB.GDT - 12/4/12 15:58 - P.1 - 2012 PROJECT FOLDERS\123-94128 LUMINANT POND SLOPE STABILITY\MARTIN LAKE\LAB TESTING\94128\MARTINLAKE.GPJ

DEPTH (ft)	GRAPHIC LOG	MATERIAL DESCRIPTION	SAMPLE TYPE NUMBER	RECOVERY % (RQD)	BLOW COUNTS (N VALUE)	POCKET PEN. (tsf)	DRY UNIT WT. (pcf)	▲ SPT N VALUE ▲			
								PL	MC	LL	
								□ FINES CONTENT (%) □			
								20	40	60	80
0		(CL) LEAN CLAY, medium plasticity, some silt, trace sand, tan and gray, mottled, dry, hard									
		with silty sand seams, very stiff at 2.0'	SH 1	50		4.0					
		stiff at 4.0'	SH 2	60		3.5					
5		very stiff at 6.0'	SH 3	40		1.25					
			SH 4	58		3.75					
			SH 5	44		3.5					
10		some to little silt at 13.0'									
			SH 6	42		3.0					
15		some clayey sand seams, stiff at 18.0'									
			SH 7	40		1.5					
20		(CL) SILTY CLAY, low plasticity, some sand, dark gray, moist, stiff									
			SH 8	67		1.75					
25		(CL) SANDY SILTY CLAY, low plasticity, little clay, light gray with little brown, moist, stiff									
			SS 9	67	2-5-7 (12)						
30		(CL) SANDY CLAY, low plasticity, some silt, tan and gray, moist, very stiff									
			SH 10	60		3.0					
35											

(Continued Next Page)



500 Century Plaza Drive, Suite 190
Houston, Texas 77073
Telephone: (281) 821-6868
Fax: (281) 821-6870

BORING NUMBER BH-205

CLIENT Luminant PROJECT NAME Pond Slope Stability
PROJECT NUMBER 123-94128 PROJECT LOCATION Martin Lake

DEPTH (ft)	GRAPHIC LOG	MATERIAL DESCRIPTION	SAMPLE TYPE NUMBER	RECOVERY % (RQD)	BLOW COUNTS (N VALUE)	POCKET PEN. (tsf)	DRY UNIT WT. (pcf)	▲ SPT N VALUE ▲	
								PL	MC LL
								□ FINES CONTENT (%) □	
								20	40 60 80
35									
40		(SC) CLAYEY SAND, interbedded with gray silty SAND, fine, subangular, little clay, compact, wet	SS 11	100	3-6-8 (14)			▲ ●	
45		(SP) SAND, fine, subangular, non-plastic, some clay, little silt, tan and brown, wet, compact	SS 12	100	4-9-12 (21)			▲ ●	
50		medium to fine, tan at 48.0'	SS 13	100	3-6-11 (17)			▲ ●	
55		very loose at 53.0'	SS 14	33				□ ●	
60		Bottom of borehole at 60.0 feet.							

GEOTECH BH PLOTS - GINT STD US LAB.GDT - 12/4/12 15:58 - P.1 - 2012 PROJECT FOLDERS\123-94128 LUMINANT POND SLOPE STABILITY\MARTIN LAKE\LAB TESTING\94128\MARTINLAKE.GPJ



500 Century Plaza Drive, Suite 190
Houston, Texas 77073
Telephone: (281) 821-6868
Fax: (281) 821-6870

BORING NUMBER BH-206

PAGE 1 OF 2

CLIENT Luminant
PROJECT NUMBER 123-94128
DATE STARTED 10/30/12 **COMPLETED** 10/30/12
DRILLING CONTRACTOR WEST Drilling
DRILLING METHOD Hollow Stem Auger
LOGGED BY FW **CHECKED BY** MP
NOTES _____

PROJECT NAME Pond Slope Stability
PROJECT LOCATION Martin Lake
GROUND ELEVATION 330.5 ft **HOLE SIZE** 8 inches
GROUND WATER LEVELS:
▽ **AT TIME OF DRILLING** 30.20 ft / Elev 300.30 ft
AT END OF DRILLING ---
AFTER DRILLING ---

DEPTH (ft)	GRAPHIC LOG	MATERIAL DESCRIPTION	SAMPLE TYPE NUMBER	RECOVERY % (RQD)	BLOW COUNTS (N VALUE)	POCKET PEN. (tsf)	DRY UNIT WT. (pcf)	▲ SPT N VALUE ▲			
								PL	MC	LL	
								□ FINES CONTENT (%) □			
								20	40	60	80
0		(CL) SANDY CLAY, low plasticity, some silt, tan and gray, mottled, dry, stiff	SH 1	44		2.25		●			
		decreased sand content, very stiff at 2.0'	SH 2	67		3.5		●	—		
5		interbedded with silty clay layers, very stiff at 4.0'	SH 3	50		2.25		●			
		some silty sand veins, very stiff at 6.0'	SH 4	67		3.5		●			
10			SH 5	52		3.5		●			
15		trace organics, hard at 13.0'	SH 6	54		4.5		●			
20		with clayey sand veins, hard at 18.0'	SH 7	50		5.0		●			
25		some red, moist at 23.0'	SH 8	50		4.5		●			
30	▽	(CH) SANDY CLAY, medium to high plasticity, some silt, tan and gray, very stiff	SH 9	52		3.25		●	—		
35		increased sand and silt content, dark gray, stiff at 33.0'	SH 10	56		1.5		●			

(Continued Next Page)

GEO TECH BH PLOTS - GINT STD US LAB.GDT - 12/4/12 15:58 - P.1 - 2012 PROJECT FOLDERS\123-94128 LUMINANT POND SLOPE STABILITY\MARTIN LAKE\LAB TESTING\94128\MARTINLAKE.GPJ



CLIENT Luminant

PROJECT NAME Pond Slope Stability

PROJECT NUMBER 123-94128

PROJECT LOCATION Martin Lake

DEPTH (ft)	GRAPHIC LOG	MATERIAL DESCRIPTION	SAMPLE TYPE NUMBER	RECOVERY % (RQD)	BLOW COUNTS (N VALUE)	POCKET PEN. (tsf)	DRY UNIT WT. (pcf)	▲ SPT N VALUE ▲	
								PL	MC LL
								□ FINES CONTENT (%) □	
								20	40 60 80
35									
40		(SC) CLAYEY SAND, fine, subangular, low plasticity, some to little silt, gray, tan, and red, mottled, wet, compact	SS 11	100	5-6-6 (12)			▲ ●	
45		(SM) SILTY SAND, fine, subangular, non-plastic, some clay, wet, loose	SS 12	100	3-4-5 (9)			▲ ●	
50		(SP) SAND, medium to fine, trace coarse, poorly graded, subangular, non-plastic, some silt, tan, wet, compact	SS 13	100	2-6-12 (18)			▲ ●	
55		no coarse, trace clay at 53.0'	SS 14	100	5-8-13 (21)			●	
60		dense at 58.0'	SS 15	100	9-18-23 (41)			● ▲	

Bottom of borehole at 60.0 feet.

GEOTECH BH PLOTS - GINT STD US LAB.GDT - 12/4/12 15:58 - P.1 - 2012 PROJECT FOLDERS\123-94128 LUMINANT POND SLOPE STABILITY\MARTIN LAKE\LAB TESTING\94128\MARTINLAKE.GPJ



500 Century Plaza Drive, Suite 190
Houston, Texas 77073
Telephone: (281) 821-6868
Fax: (281) 821-6870

BORING NUMBER BH-207

PAGE 1 OF 2

CLIENT Luminant
PROJECT NUMBER 123-94128
DATE STARTED 10/31/12 **COMPLETED** 10/31/12
DRILLING CONTRACTOR WEST Drilling
DRILLING METHOD Hollow Stem Auger
LOGGED BY FW **CHECKED BY** MP
NOTES _____

PROJECT NAME Pond Slope Stability
PROJECT LOCATION Martin Lake
GROUND ELEVATION 330.5 ft **HOLE SIZE** 8 inches
GROUND WATER LEVELS:
▽ **AT TIME OF DRILLING** 34.40 ft / Elev 296.10 ft
AT END OF DRILLING ---
AFTER DRILLING ---

GEOTECH BH PLOTS - GINT STD US LAB.GDT - 12/4/12 15:58 - P.1 - 2012 PROJECT FOLDERS\123-94128 LUMINANT POND SLOPE STABILITY\MARTIN LAKE\LAB TESTING\94128\MARTINLAKE.GPJ

DEPTH (ft)	GRAPHIC LOG	MATERIAL DESCRIPTION	SAMPLE TYPE NUMBER	RECOVERY % (RQD)	BLOW COUNTS (N VALUE)	POCKET PEN. (tsf)	DRY UNIT WT. (pcf)	▲ SPT N VALUE ▲				
								20	40	60	80	
0		remove 8" of SANDY GRAVEL from roadbed										
		(CL) SILTY CLAY, low plasticity, trace fine sand, gray, dry, hard	SH 1	33		5.0						
		(CL) SANDY CLAY, low plasticity, some silt and interbedded sand seams, tan and gray, mottled, dry, firm	SH 2	58		3.0						
5		(SP) SAND, poorly graded, non-plastic, some silt, clay, and gravel, black and tan, dry	SH 3	38		0.0						
		(CL) SANDY CLAY, low plasticity, some silt, gray and tan, dry, firm	SH 4	54		3.0						
		hard at 8.0'	SH 5	50		5.0						
		decrease sand content, stiff at 13.0'	SH 6	56		3.75						
		some sand seams at 18.0'	SH 7	52		2.5						
25		(SM) SILTY SAND, non-plastic, fine, subangular, little clay, gray, moist	SH 8	33								
30		(CL) SILTY CLAY, non-plastic, some sand, gray, moist, hard	SH 9	60		5.0						
35		(SM) SILTY SAND, non-plastic, fine, subangular, little clay, gray with little tan, moist, compact	SS 10	89	6-7-7 (14)							

(Continued Next Page)



CLIENT Luminant PROJECT NAME Pond Slope Stability
PROJECT NUMBER 123-94128 PROJECT LOCATION Martin Lake

DEPTH (ft)	GRAPHIC LOG	MATERIAL DESCRIPTION	SAMPLE TYPE NUMBER	RECOVERY % (RQD)	BLOW COUNTS (N VALUE)	POCKET PEN. (tsf)	DRY UNIT WT. (pcf)	▲ SPT N VALUE ▲	
								PL	MC LL
								□ FINES CONTENT (%) □	
								20	40 60 80
35									
40		(SC) CLAYEY SAND, non-plastic, fine, subangular, some silt, gray and tan, wet, loose	SS 11	67	2-3-4 (7)				
45		compact at 43.0'	SS 12	100	3-5-5 (10)				
50			SS 13	100	3-5-6 (11)				
55		(SP) SAND, medium to fine, non-plastic, some silt and clay, gray and tan, wet, loose	SS 14	89	2-2-5 (7)				
60		(CL) SILTY CLAY, low plasticity, trace fine sand, gray, wet, very stiff	SS 15	100	3-7-12 (19)				

Bottom of borehole at 60.0 feet.

GEOTECH BH PLOTS - GINT STD US LAB.GDT - 12/4/12 15:58 - P.1 - 2012 PROJECT FOLDERS\123-94128 LUMINANT POND SLOPE STABILITY\MARTIN LAKE\LAB TESTING\94128\MARTINLAKE.GPJ



500 Century Plaza Drive, Suite 190
Houston, Texas 77073
Telephone: (281) 821-6868
Fax: (281) 821-6870

BORING NUMBER BH-208

PAGE 1 OF 2

CLIENT Luminant
PROJECT NUMBER 123-94128
DATE STARTED 10/31/12 **COMPLETED** 10/31/12
DRILLING CONTRACTOR WEST Drilling
DRILLING METHOD Hollow Stem Auger
LOGGED BY FW **CHECKED BY** MP
NOTES _____

PROJECT NAME Pond Slope Stability
PROJECT LOCATION Martin Lake
GROUND ELEVATION 330.5 ft **HOLE SIZE** 8 inches
GROUND WATER LEVELS:
▽ **AT TIME OF DRILLING** 30.00 ft / Elev 300.50 ft
AT END OF DRILLING ---
AFTER DRILLING ---

DEPTH (ft)	GRAPHIC LOG	MATERIAL DESCRIPTION	SAMPLE TYPE NUMBER	RECOVERY % (RQD)	BLOW COUNTS (N VALUE)	POCKET PEN. (tsf)	DRY UNIT WT. (pcf)	▲ SPT N VALUE ▲				
								20	40	60	80	
0		remove 12" of SANDY GRAVEL from roadbed										
2.0		(CL) SANDY CLAY, low plasticity, some silt, tan and gray, dry, stiff to very stiff at 2.0'	SH 1	44		3.5						
4.0		hard at 4.0'	SH 2	50		4.0						
5.0			SH 3	54		5.0						
7.0		SILTY SAND, nonplastic, some clay, dry	SH 4	31		1.5						
10.0		(CL) SANDY CLAY, low plasticity, some silt, tan, gray, and red, dry, soft to firm	SH 5	50		2.0						
15.0			SH 6	40		2.5						
18.0		very stiff at 18.0'	SH 7	50		3.5						
23.0		hard at 23.0'	SH 8	46		5.0						
28.0		some sand seams, moist, very stiff at 28.0'	SH 9	54		3.0						
35.0		(SC) CLAYEY SAND, fine, subangular, some silt, tan, gray, and red, moist	SH 10	60		2.5						

GEO TECH BH PLOTS - GINT STD US LAB.GDT - 12/4/12 15:58 - P.1 - 2012 PROJECT FOLDERS\123-94128 LUMINANT POND SLOPE STABILITY\MARTIN LAKE\LAB TESTING\94128\MARTINLAKE.GPJ

(Continued Next Page)



500 Century Plaza Drive, Suite 190
Houston, Texas 77073
Telephone: (281) 821-6868
Fax: (281) 821-6870

BORING NUMBER BH-208

PAGE 2 OF 2

CLIENT Luminant PROJECT NAME Pond Slope Stability
PROJECT NUMBER 123-94128 PROJECT LOCATION Martin Lake

DEPTH (ft)	GRAPHIC LOG	MATERIAL DESCRIPTION	SAMPLE TYPE NUMBER	RECOVERY % (RQD)	BLOW COUNTS (N VALUE)	POCKET PEN. (tsf)	DRY UNIT WT. (pcf)	▲ SPT N VALUE ▲	
								20 40 60 80	20 40 60 80
								PL	MC LL
								20 40 60 80	20 40 60 80
								□ FINES CONTENT (%) □	
								20 40 60 80	20 40 60 80
35									
40		wet at 38.0'	SH 11	50					
45		loose at 43.0'	SS 12	100	3-2-3 (5)				
50		(SP) SAND, fine, little medium, non-plastic, subangular, little clay, tan, compact	SS 13	72	1-6-8 (14)				
55		(SC) CLAYEY SAND, medium, some silt, brown (SM) SILTY SAND, fine, subangular, non-plastic, little clay, gray, compact	SS 14	100	3-6-7 (13)				
60		(CL) SILTY CLAY, low plasticity, dark gray, dense SANDY GRAVEL, non-plastic, planar, lignite coal seam, black, hard	SS 15	100	7-43-50 (93)				

Bottom of borehole at 60.0 feet.

GEOTECH BH PLOTS - GINT STD US LAB.GDT - 12/4/12 15:58 - P.1 - 2012 PROJECT FOLDERS\123-94128 LUMINANT POND SLOPE STABILITY\MARTIN LAKE\LAB TESTING\94128\MARTINLAKE.GPJ



500 Century Plaza Drive, Suite 190
Houston, Texas 77073
Telephone: (281) 821-6868
Fax: (281) 821-6870

BORING NUMBER BH-209

PAGE 1 OF 2

CLIENT Luminant
PROJECT NUMBER 123-94128
DATE STARTED 11/1/12 **COMPLETED** 11/1/12
DRILLING CONTRACTOR WEST Drilling
DRILLING METHOD Hollow Stem Auger
LOGGED BY FW **CHECKED BY** MP
NOTES _____

PROJECT NAME Pond Slope Stability
PROJECT LOCATION Martin Lake
GROUND ELEVATION 360 ft **HOLE SIZE** 8 inches
GROUND WATER LEVELS:
▽ **AT TIME OF DRILLING** 46.20 ft / Elev 313.80 ft no reading, cave in at 46
AT END OF DRILLING ---
AFTER DRILLING ---

DEPTH (ft)	GRAPHIC LOG	MATERIAL DESCRIPTION	SAMPLE TYPE NUMBER	RECOVERY % (RQD)	BLOW COUNTS (N VALUE)	POCKET PEN. (tsf)	DRY UNIT WT. (pcf)	▲ SPT N VALUE ▲		
								20	40	60
0		(SC) CLAYEY SAND, fine, subangular, medium plasticity, some fine rounded gravel, red and brown, dry	SH 1	33		5.0		●		
		trace fine rounded gravel, tan and gray, mottled at 2.0'	SH 2	38		5.0		●		
5		little silt, no gravel at 4.0'	SH 3	38		5.0		●	—	—
		some silt at 6.0'	SH 4	29		4.5		●		
10		(CL) SANDY CLAY, low plasticity, some silt, tan and gray, dry, firm	SS 5	33	2-2-5 (7)			▲ ●		
		some red, hard at 13.0'	SH 6	21		5.0		●		
20		gray, moist, very stiff at 18.0'	SH 7	29		2.5		●		
25		(CL) LEAN CLAY, low plasticity, some silt, trace fine sand, gray and tan, moist, stiff	SS 8	67	4-6-8 (14)			▲		
		little silt, hard, gray at 28.0'	SH 9	50		5.0		●	—	—
35		grading to clayey sand, very stiff at 33.0'	SH 10	42		3.0		●		

(Continued Next Page)

GEOTECH BH PLOTS - GINT STD US LAB.GDT - 12/4/12 15:58 - P.1 - 2012 PROJECT FOLDERS\123-94128 LUMINANT POND SLOPE STABILITY\MARTIN LAKE\LAB TESTING\94128\MARTINLAKE.GPJ



CLIENT Luminant PROJECT NAME Pond Slope Stability
PROJECT NUMBER 123-94128 PROJECT LOCATION Martin Lake

DEPTH (ft)	GRAPHIC LOG	MATERIAL DESCRIPTION	SAMPLE TYPE NUMBER	RECOVERY % (RQD)	BLOW COUNTS (N VALUE)	POCKET PEN. (tsf)	DRY UNIT WT. (pcf)	▲ SPT N VALUE ▲			
								20	40	60	80
								PL	MC	LL	
								20	40	60	80
								□ FINES CONTENT (%) □			
								20	40	60	80
35											
40		some silt and sand, gray, tan, and brown, hard at 38.0'	SS 11	100	7-13-14 (27)						
45		(CL) SILTY CLAY, low plasticity, dark gray, moist, hard	SS 12	100	12-20-26 (46)						
50		(SM) SILTY SAND, fine, subangular, non-plastic, some clay, tan and gray, moist, very dense	SS 13	100	14-27-36 (63)						

Bottom of borehole at 50.0 feet.

GEOTECH BH PLOTS - GINT STD US LAB.GDT - 12/4/12 15:58 - P.1 - 2012 PROJECT FOLDERS\123-94128 LUMINANT POND SLOPE STABILITY\MARTIN LAKE\LAB TESTING\94128\MARTINLAKE.GPJ

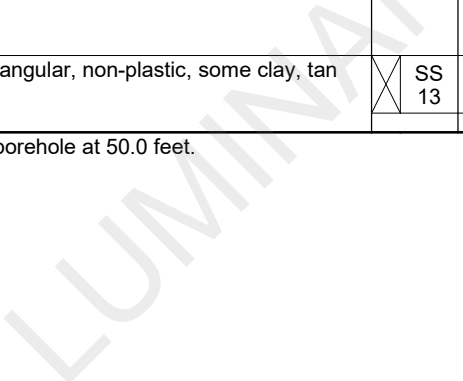



500 Century Plaza Drive, Suite 190
Houston, Texas 77073
Telephone: (281) 821-6868
Fax: (281) 821-6870

BORING NUMBER BH-210

PAGE 1 OF 2

CLIENT Luminant
PROJECT NUMBER 123-94128
DATE STARTED 11/1/12 **COMPLETED** 11/1/12
DRILLING CONTRACTOR WEST Drilling
DRILLING METHOD Hollow Stem Auger
LOGGED BY FW **CHECKED BY** MP
NOTES _____

PROJECT NAME Pond Slope Stability
PROJECT LOCATION Martin Lake
GROUND ELEVATION 360 ft **HOLE SIZE** 8 inches
GROUND WATER LEVELS:
▽ **AT TIME OF DRILLING** 47.00 ft / Elev 313.00 ft no reading, cave in at 47
AT END OF DRILLING ---
AFTER DRILLING ---

GEOTECH BH PLOTS - GINT STD US LAB.GDT - 12/4/12 15:58 - P.1 - 2012 PROJECT FOLDERS\123-94128 LUMINANT POND SLOPE STABILITY\MARTIN LAKE\LAB TESTING\94128\MARTINLAKE.GPJ

DEPTH (ft)	GRAPHIC LOG	MATERIAL DESCRIPTION	SAMPLE TYPE NUMBER	RECOVERY % (RQD)	BLOW COUNTS (N VALUE)	POCKET PEN. (tsf)	DRY UNIT WT. (pcf)	▲ SPT N VALUE ▲			
								PL	MC	LL	
								□ FINES CONTENT (%) □			
								20	40	60	80
0		(SC) CLAYEY SAND, fine, subangular, some silt, little fine rounded gravel, red, dry trace roots at 1.0' tan, gray, and red, mottled at 2.0'	SH 1	25		5.0		●			
			SH 2	21		5.0		●			
5		compact at 4.0'	SS 3	67	4-7-10 (17)			●			
			SS 4	39	3-6-6 (12)			●			
			SS 5	33	3-4-6 (10)			▲			
15		(CL) SANDY CLAY, low to medium plasticity, little silt, red and gray, dry, very stiff	SH 6	21		3.0		●			
20		some silt and sand seams, gray and tan, moist, very stiff at 18.0'	SH 7	89		3.5		●			
25		little red, hard at 23.0'	SH 8	50		4.5		●			
30		trace subrounded fine gravels and coarse sand at 28.0'	SH 9	29		4.0		●			
35		(SC) CLAYEY SAND, fine, subangular, some silt, brown and tan, moist	SH 10	35		4.0		●			

(Continued Next Page)



CLIENT Luminant PROJECT NAME Pond Slope Stability
PROJECT NUMBER 123-94128 PROJECT LOCATION Martin Lake

DEPTH (ft)	GRAPHIC LOG	MATERIAL DESCRIPTION	SAMPLE TYPE NUMBER	RECOVERY % (RQD)	BLOW COUNTS (N VALUE)	POCKET PEN. (tsf)	DRY UNIT WT. (pcf)	▲ SPT N VALUE ▲		
								20	40	60
								PL MC LL 20 40 60 80		
								<input type="checkbox"/> FINES CONTENT (%) <input type="checkbox"/> 20 40 60 80		
35										
40		(SM) SILTY SAND, fine, subangular, non-plastic, little clay, dark gray, moist, compact	SS 11	50	4-5-5 (10)					
45		(CL) SILTY CLAY, low plasticity, little fine sand, gray, moist, stiff	SS 12	94	2-4-5 (9)					
50		(SM) SILTY SAND, fine, subangular, non-plastic, some clay, gray and tan, mottled, wet, compact	SS 13	100	4-7-8 (15)					
55			SS 14	89	5-9-9 (18)					
60		little tan, dense at 58.0'	SS 15	100	7-14-17 (31)					
65			SS 16	100	11-15-19 (34)					
70		some dark brown clay seams at 68.0'	SS 17	100	10-15-25 (40)					

Bottom of borehole at 70.0 feet.

GEOTECH BH PLOTS - GINT STD US LAB.GDT - 12/4/12 15:58 - P.1 - 2012 PROJECT FOLDERS\123-94128 LUMINANT POND SLOPE STABILITY\MARTIN LAKE\LAB TESTING\94128\MARTINLAKE.GPJ



500 Century Plaza Drive, Suite 190
Houston, Texas 77073
Telephone: (281) 821-6868
Fax: (281) 821-6870

BORING NUMBER BH-211

PAGE 1 OF 2

CLIENT Luminant
PROJECT NUMBER 123-94128
DATE STARTED 11/2/12 COMPLETED 11/2/12
DRILLING CONTRACTOR WEST Drilling
DRILLING METHOD Hollow Stem Auger
LOGGED BY FW CHECKED BY MP
NOTES _____

PROJECT NAME Pond Slope Stability
PROJECT LOCATION Martin Lake
GROUND ELEVATION 360 ft HOLE SIZE 8 inches
GROUND WATER LEVELS:
▽ AT TIME OF DRILLING 60.20 ft / Elev 299.80 ft no reading, cave in at 60
AT END OF DRILLING ---
AFTER DRILLING ---

DEPTH (ft)	GRAPHIC LOG	MATERIAL DESCRIPTION	SAMPLE TYPE NUMBER	RECOVERY % (RQD)	BLOW COUNTS (N VALUE)	POCKET PEN. (tsf)	DRY UNIT WT. (pcf)	▲ SPT N VALUE ▲			
								PL	MC	LL	
								□ FINES CONTENT (%) □			
								20	40	60	80
0		(SC) CLAYEY SAND, some silt and fine rounded gravel, red, dry									
		fine, subangular, gray, tan, and red at 2.0'	SH 1	29		5.0					
		trace fine gravels and coarse sand, loose at 4.0'	SH 2	29		3.5					
5		some sandy clay seams, compact at 6.0'	SS 3	50	2-3-6 (9)						
		increase clay and silt content at 8.0'	SS 4	39	4-5-8 (13)						
10			SS 5	72	4-8-8 (16)						
15		(CL-CH) SANDY CLAY, low to medium plasticity, little silt, gray, tan, and red, dry, stiff	SS 6	33	2-5-6 (11)						
		some silt at 18.0'	SH 7	50		3.25					
20		brown and tan at 23.0'	SH 8	44		5.0					
25			SH 9	25							
30		(ML) SANDY SILT, little clay, tan, moist									
35		(SM) SILTY SAND, fine, subangular, some clay, tan and gray, dense	SS 10	67	7-15-19 (34)						

(Continued Next Page)

GEOTECH BH PLOTS - GINT STD US LAB.GDT - 12/4/12 15:58 - P.1 - 2012 PROJECT FOLDERS\123-94128 LUMINANT POND SLOPE STABILITY\MARTIN LAKE\LAB TESTING\94128\MARTINLAKE.GPJ



CLIENT Luminant PROJECT NAME Pond Slope Stability
PROJECT NUMBER 123-94128 PROJECT LOCATION Martin Lake

DEPTH (ft)	GRAPHIC LOG	MATERIAL DESCRIPTION	SAMPLE TYPE NUMBER	RECOVERY % (RQD)	BLOW COUNTS (N VALUE)	POCKET PEN. (tsf)	DRY UNIT WT. (pcf)	▲ SPT N VALUE ▲		
								20	40	60
								PL MC LL 20 40 60 80		
								<input type="checkbox"/> FINES CONTENT (%) <input type="checkbox"/> 20 40 60 80		
35										
40			SS 11	89	9-17-25 (42)					
45			SS 12	100	10-14-18 (32)					
50		(SC) CLAYEY SAND, low plasticity, fine, subangular, some silt and lean clay, gray and tan, wet, dense	SS 13	89	9-14-18 (32)					
55		(SP) SAND, fine, subangular, non-plastic, some silt, little to trace clay, tan, wet, very dense	SS 14	100	17-29-38 (67)					
60		little medium at 58.0'	SS 15	78	14-28-33 (61)					
65			SS 16	100	17-29-34 (63)					
70		(SM) SILTY SAND, fine, subangular, non-plastic, little to trace clay, gray and tan, wet, very dense	SS 17	72	18-27-37 (64)					
Bottom of borehole at 70.0 feet.										

GEOTECH BH PLOTS - GINT STD US LAB.GDT - 12/4/12 15:58 - P.1 - 2012 PROJECT FOLDERS\123-94128 LUMINANT POND SLOPE STABILITY\MARTIN LAKE\LAB TESTING\94128\MARTINLAKE.GPJ

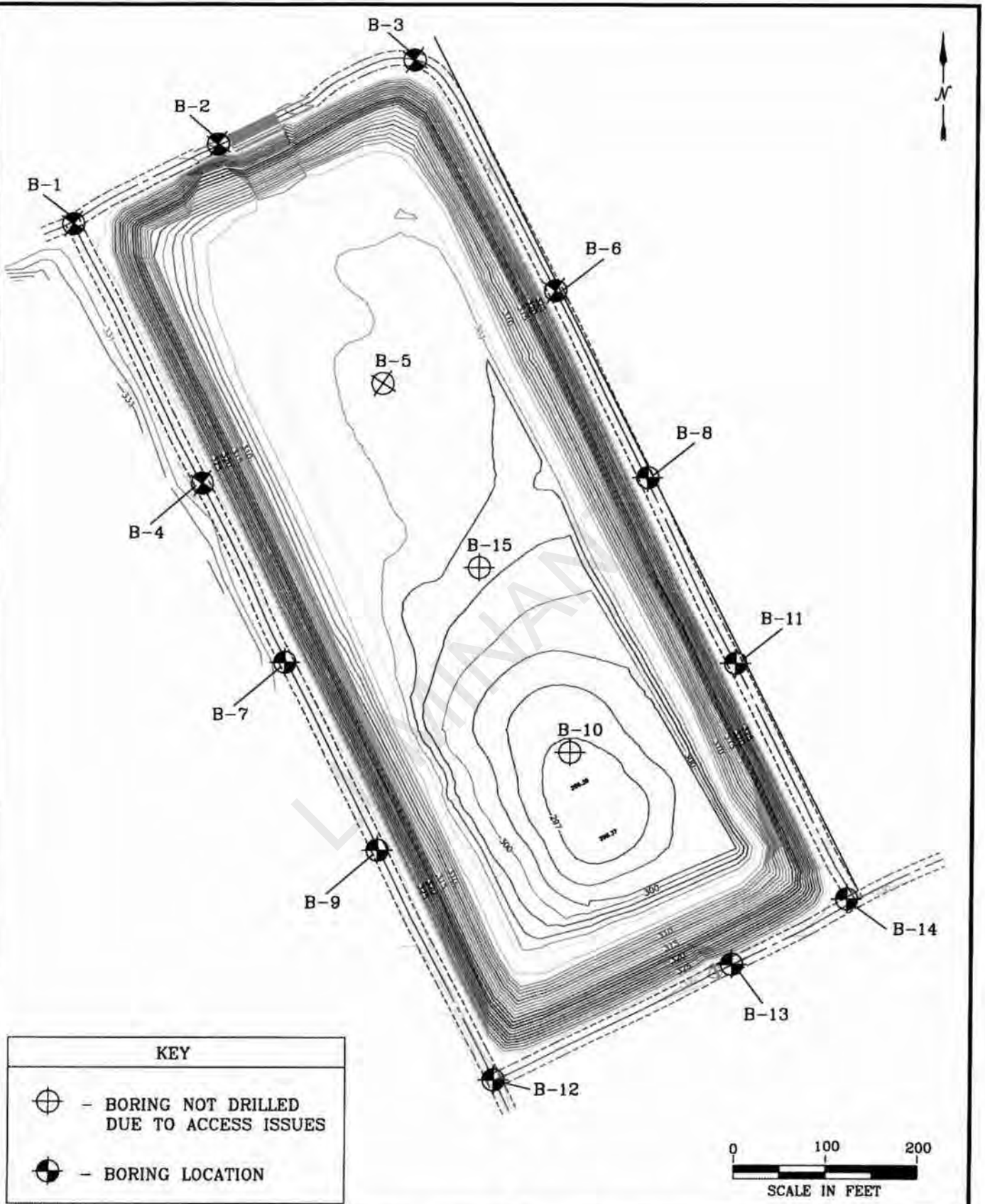

KEY	
	- BORING NOT DRILLED DUE TO ACCESS ISSUES
	- BORING LOCATION

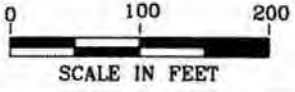

**ETTL
ENGINEERS &
CONSULTANTS**
MAIN OFFICE
1717 East Greer
Ft. Worth, Texas 75102
(803) 595-4421

**MARTIN LAKE
LUMINANT
EAST ASH DISPOSAL POND
RUSK COUNTY, TEXAS**

PLATE 1 - PLAN OF BORINGS
JOB NO.: G 2972-08
DATE: NOV. 2008 SCALE: AS SHOWN

APPROVED BY:

DRAWN BY:
K.C.R.



**ETTL
ENGINEERS &
CONSULTANTS**

MAIN OFFICE
1717 East Erwin
Tyler, Texas 75702
(903) 595-4421

MATERIAL DESCRIPTION

SANDY LEAN CLAY (CL) hard; red, tan, and gray;
mottled
--very stiff
--with trace lignite

CL

SM

SILTY SAND (SM) medium dense; red, tan, and
gray
--with gravel

LEAN CLAY WITH SAND (CL) very stiff; red, tan,
and gray; interbedded; laminated
Bottom of Boring @ 40'

LOG OF BORING B-1

PROJECT: Martin Lake - Luminant East Ash Disposal
Rusk County, Texas

PROJECT NO.: G 2972-08

BORING TYPE: Flight Auger

DATE: 10/8/08

SURFACE ELEVATION

FIELD STRENGTH DATA	BLOW COUNT ● 20 40 60 80 ▲ Qu (tsf) ▲ 1 2 3 4 ■ PPR (tsf) ■ 1.0 2.0 3.0 4.0 ◆ Torvane (tsf) ◆ 1.0 2.0 3.0 4.0	DRY DENSITY (pcf)	COMPRESSIVE STRENGTH (tsf)	FAILURE STRAIN (%)	CONFINING PRESSURE (psi)	Natural Moisture Content and Atterberg Limits		MOISTURE CONTENT (%)	ATTERBERG LIMITS (%)	MINUS #200 SIEVE (%)	OTHER TESTS PERFORMED (Page Ref. #)
						Plastic Limit	Liquid Limit				
P=4.5+	■					28	14	9	LL 28 PL 14	55	+40 Sieve =0%, +4 Sieve =0%
P=3.75	■										
P=3.0	■										
P=2.75	■					37	14	16	LL 37 PL 14	66	+40 Sieve =1%, +4 Sieve =0%
P=4.5+	■										
N=11	●										
N=16	●										
N=19	●										
N=22	●										
N=17	●					39	16	17	LL 39 PL 16	70	+40 Sieve =1%, +4 Sieve =0%

Notes:

GPS Coordinates: N 32° 15.850', W 94° 33.910'

Key to Abbreviations:
N - SPT Data (Blows/Ft)
P - Pocket Penetrometer (tsf)
T - Torvane (tsf)
L - Lab Vane Shear (tsf)

USC

WATER LEVEL

SAMPLES

DEPTH (ft)

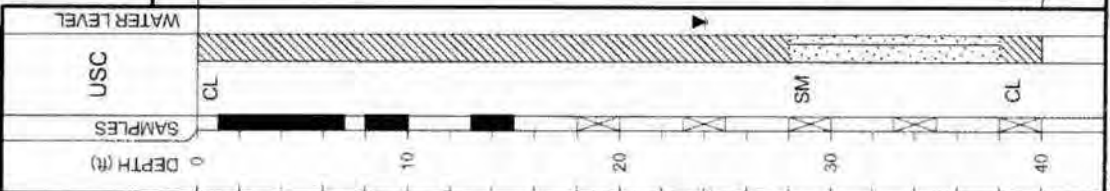

Water Level

Water Observations:
Seepage @ 28' while drilling. Water level
@ 26' and open to 33' upon completion. Water level @ 24' and
open to 27' on 10/9/08.



**ETTL
ENGINEERS &
CONSULTANTS**

MAIN OFFICE
1717 East Erwin
Tyler, Texas 75702
(903) 595-4421

MATERIAL DESCRIPTION

CLAYEY SAND(SC) tan, gray, and red, mottled;
with gravel

SANDY LEAN CLAY(CL) very stiff, tan, gray, and
red, mottled

--stiff

--red and gray, mottled

--tan, red, and gray, mottled

SILTY SAND(SM) medium dense; gray

Bottom of Boring @ 40'

LOG OF BORING B-11

PROJECT: Martin Lake - Luminant East Ash Disposal
Rusk County, Texas

PROJECT NO.: G 2972-08

BORING TYPE: Flight Auger

DATE: 10/7/08

SURFACE ELEVATION

FIELD STRENGTH DATA	BLOW COUNT				DRY DENSITY (pcf)	COMPRESSION STRENGTH (tsf)	FAILURE STRAIN (%)	CONFINING PRESSURE (psi)	Natural Moisture Content and Atterberg Limits			MOISTURE CONTENT (%)	OTHER TESTS PERFORMED (Page Ref. #)
	1	2	3	4					Plastic Limit	Moisture Content	Liquid Limit		
P=3.0	1	2	3	4					28	12	16	33	+40 Sieve =28%, +4 Sieve =24%
P=2.25									13	13	19	56	+40 Sieve =1%, +4 Sieve =0%
N=17									16	38	24	68	+40 Sieve =1%, +4 Sieve =0%
N=11													
P=2.25													
P=3.25													
P=2.25													
N=15													
N=16													

Key to Abbreviations:
N - SPT Data (Blows/Ft)
P - Pocket Penetrometer (tsf)
T - Torvane (tsf)
L - Lab Vane Shear (tsf)

Notes:

GPS Coordinates: N 32°15.773', W 94°33.782'

Water Observations:
Seepage @ 38' while drilling. Water level @ 36' and open to 37' upon completion. Water level @ 21' and open to 22' on 10/8/08.

Est.: Measured: Perched:



**ETTL
ENGINEERS &
CONSULTANTS**

MAIN OFFICE
1717 East Erwin
Tyler, Texas 75702
(903) 595-4421

MATERIAL DESCRIPTION

SANDY LEAN CLAY (CL) brown; with gravel
-mottled; tan, red, and gray; with sand seams
-with silty sand
LEAN CLAY WITH SAND (CL) very stiff; tan, red, and gray; mottled
-with sand seams
SILTY SAND (SM) dense; gray and red; mottled
SANDY LEAN CLAY (CL) very stiff; gray, red, and tan; mottled
Bottom of Boring @ 40'

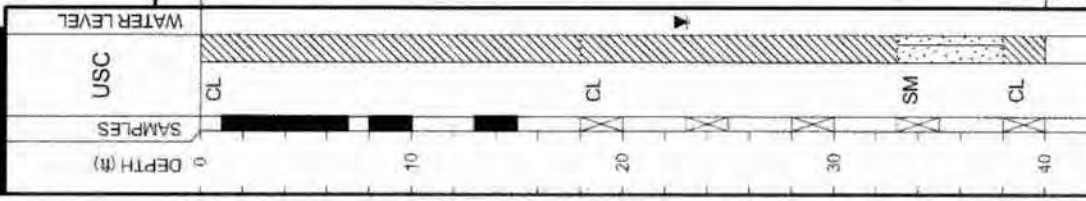

LOG OF BORING B-12
PROJECT: Martin Lake - Luminant East Ash Disposal
Rusk County, Texas
PROJECT NO.: G 2972-08
BORING TYPE: Flight Auger

FIELD STRENGTH DATA	BLOW COUNT 20 40 60 80	Cu (tsf) ▲ 1 2 3 4	PPR (tsf) ■ 1.0 2.0 3.0 4.0	Torvane (tsf) ◆ 1.0 2.0 3.0 4.0	DRY DENSITY (pcf)	COMPRESSIVE STRENGTH (tsf)	FAILURE STRAIN (%)	CONFINING PRESSURE (psi)	Natural Moisture Content and Atterberg Limits			MOISTURE CONTENT (%)	ATTERBERG LIMITS (%)			OTHER TESTS PERFORMED (Page Ref. #)
									Plastic Limit	Moisture Content	Liquid Limit		LIQUID LIMIT	PLASTIC LIMIT	PLASTICITY INDEX	
P=3.5											32	15	17	54	+40 Sieve =1%, +4 Sieve =0%, +40 Sieve =0%	
N=18											30	14	16	75	+40 Sieve =1%, +4 Sieve =0%	
N=15																
N=22																
N=38																
N=18																

Notes:
GPS Coordinates: N 32° 15.696', W 94° 33.830'
Key to Abbreviations:
N - SPT Data (Blows/Ft)
P - Pocket Penetrometer (tsf)
T - Torvane (tsf)
L - Lab Vane Shear (tsf)

Water Level: Measured; Perched; Seepage @ 33' while drilling. Water level @ 34' and open to 35' upon completion. Water level @ 23' and open to 31' on 10/10/08.



**EITL
ENGINEERS &
CONSULTANTS**

MAIN OFFICE
1717 East Erwin
Tyler, Texas 75702
(903) 595-4421

DEPTH (ft)
SAMPLES
USC
WATER LEVEL

MATERIAL DESCRIPTION

SANDY LEAN CLAY (CL) very stiff; tan, gray, and red; mottled
 LEAN CLAY WITH SAND (CL) very stiff; tan, gray, and red; mottled
 -tan and brown
 CLAYEY SAND (SC) dense; tan, brown, and red; with gravel
 LEAN CLAY WITH SAND (CL) very stiff; tan, brown, and red; with lignite
 -red and tan
 -tan, red, and gray; mottled
 CLAYEY SAND (SC) loose; tan, red, and gray; with trace gravel and fern material
 -medium dense
 Bottom of Boring @ 40'

Water Level
 Water Observations:
 @ 36' and open to 38' upon completion. Water level @ 25' and open to 26' on 10/8/08.

Est: Measured: Perched:
 Seepage @ 37' while drilling. Water level @ 36' and open to 38' upon completion. Water level @ 25' and open to 26' on 10/8/08.

Key to Abbreviations:
 N - SPT Data (Blows/Ft)
 P - Pocket Penetrometer (tsf)
 T - Torvane (tsf)
 L - Lab Vane Shear (tsf)

Notes:
 GPS Coordinates: N 32°15.713', W 94°33.777'

LOG OF BORING B-13

PROJECT: Martin Lake - Luminant East Ash Disposal
 Rusk County, Texas

PROJECT NO.: G 2972-08

BORING TYPE: Flight Auger

DATE

10/7/08

SURFACE ELEVATION

MOISTURE CONTENT (%)		ATTERBERG LIMITS (%)			OTHER TESTS PERFORMED (Page Ref. #)
LIQUID LIMIT	PLASTIC LIMIT	PLASTICITY INDEX	MINUS #200 SIEVE (%)		
15	39	16	23	70	+40 Sieve =6%
10	40	16	24	47	+40 Sieve =36%, +4 Sieve =33%
17	38	16	22	74	+40 Sieve =3%, +4 Sieve =0%
18	36	17	19	43	+40 Sieve =36%, +4 Sieve =25%

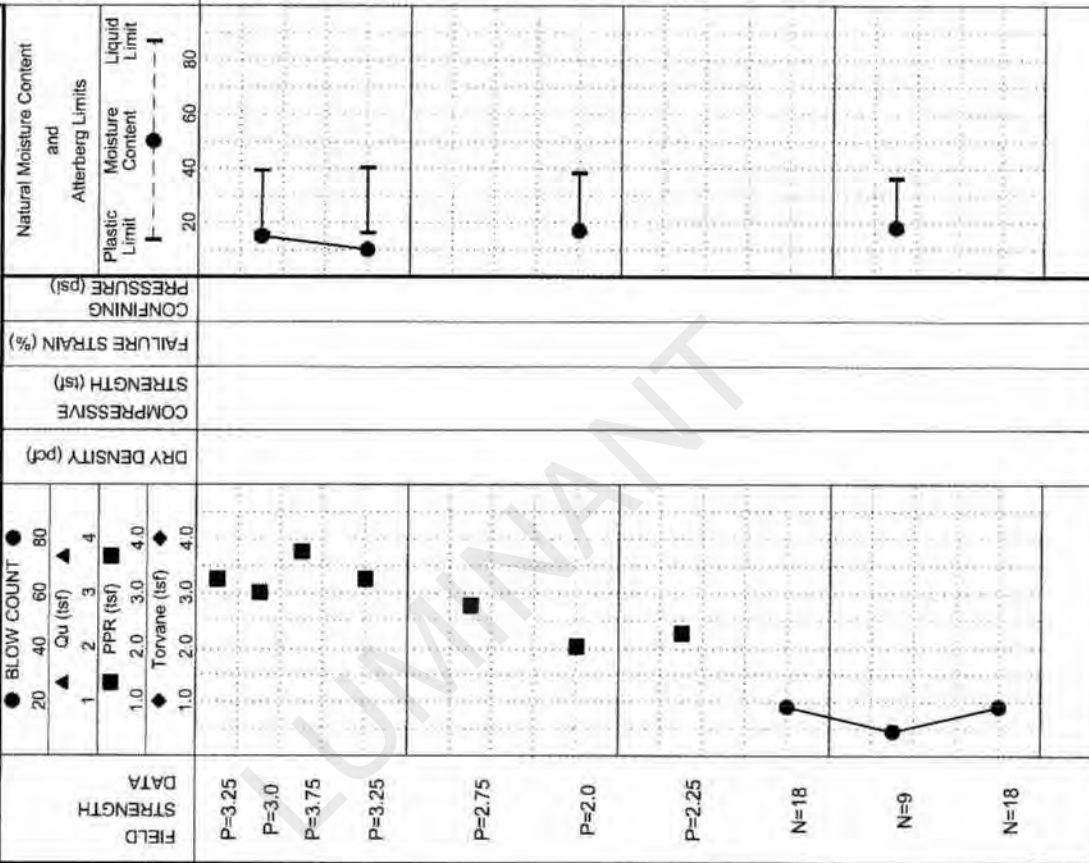

Notes:
 GPS Coordinates: N 32°15.713', W 94°33.777'



**ETTL
ENGINEERS &
CONSULTANTS**

MAIN OFFICE
1717 East Erwin
Tyler, Texas 75702
(903) 595-4421

LOG OF BORING B-14

PROJECT: Martin Lake - Luminant East Ash Disposal
Rusk County, Texas
BORING TYPE: Flight Auger
PROJECT NO.: G 2972-08

DATE
10/6/08

SURFACE ELEVATION

ATTERBERG LIMITS (%)		MOISTURE CONTENT (%)	MINUS #200 SIEVE (%)	OTHER TESTS PERFORMED (Page Ref. #)
LIQUID LIMIT (LL)	PLASTIC LIMIT (PL)			
40	16	14	53	+40 Sieve =50%, +4 Sieve =49%
29	13	13	63	+40 Sieve =1%, +4 Sieve =0%
31	16	16	58	+40 Sieve =2%, +4 Sieve =0%
40	14	12	77	+40 Sieve =1%, +4 Sieve =0%

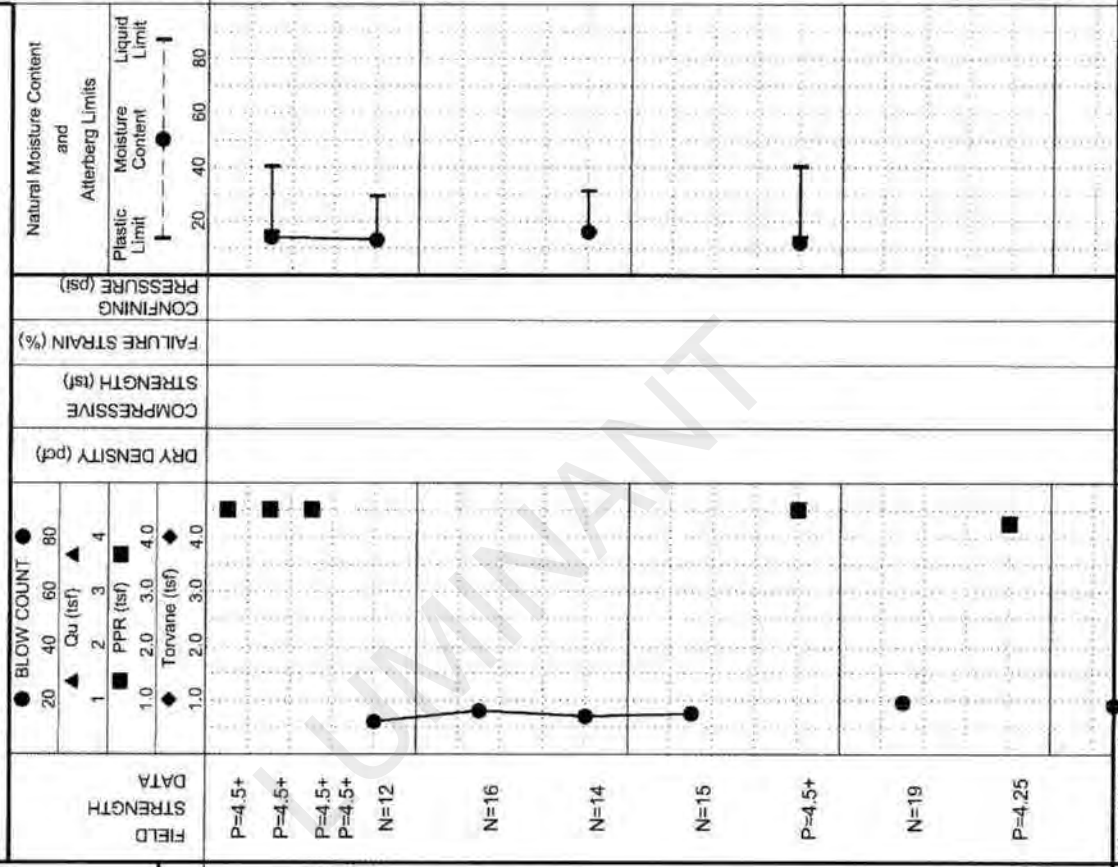

DEPTH (ft)	SAMPLES	USC	WATER LEVEL	MATERIAL DESCRIPTION
0				
0-4		CL		SANDY LEAN CLAY (CL) hard; tan, gray, and red; mottled; with gravel
4-12				-stiff
12-16		CL		SANDY LEAN CLAY (CL) very stiff; tan, gray, and red; mottled
16-19				-stiff, interbedded
19-25				-hard; brown, tan, and red
25-40		SM		-hard; with gray and brown silty sand SILTY SAND (SM) medium dense; red and gray; saturated

Notes:
GPS Coordinates: N 32° 15.723', W 94° 33.756'

Key to Abbreviations:
N - SPT Data (Blows/Ft)
P - Pocket Penetrometer (tsf)
T - Torvane (tsf)
L - Lab Vane Shear (tsf)

Water Level: Measured: Perched:
Water level @ 22' and open to 89' upon completion. Water level @ 26' and open to 27' on 10/9/08.



ETTL
ENGINEERS &
CONSULTANTS

MAIN OFFICE
 1717 East Erwin
 Tyler, Texas 75702
 (903) 595-4421

MATERIAL DESCRIPTION

USC
 WATER LEVEL
 DEPTH (#)
 SAMPLES
 50
 60
 70
 80
 CL
 SM
 CL
 -red and tan
 LEAN CLAY WITH SAND(CL) hard; red and tan; interbedded; laminated; with ferric material seams
 -with black lignite seams
 SILTY SAND(SM) very dense; gray; with fat clay partings
 -gray
 LEAN CLAY(CL) hard; gray

Water Level
 Est. Measured: Perched:
 Water Observations:
 Water level @ 22' and open to 89' upon completion. Water level @ 26' and open to 27' on 10/9/08.

LOG OF BORING B-14

PROJECT: Martin Lake - Luminant East Ash Disposal
 Rusk County, Texas
 BORING TYPE: Flight Auger
 PROJECT NO.: G 2972-08

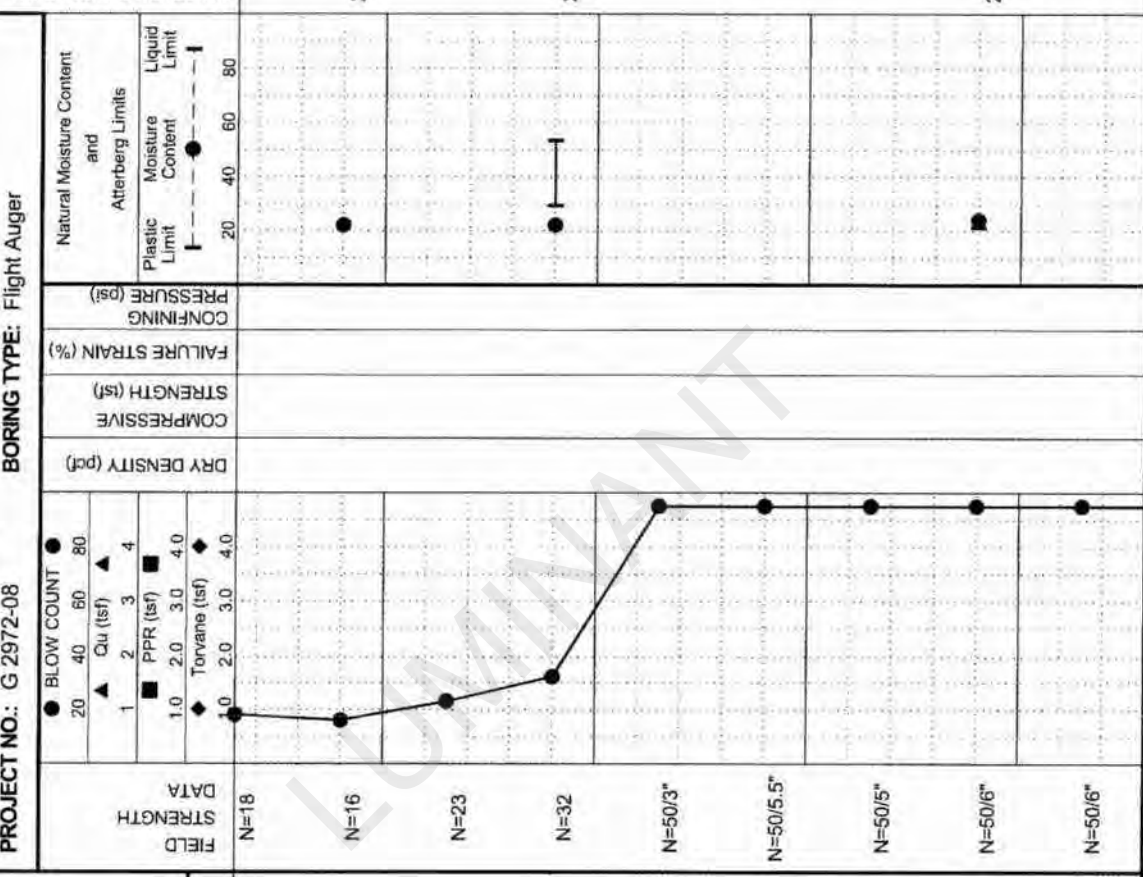

DATE: 10/6/08
 SURFACE ELEVATION

MOISTURE CONTENT (%)	LIQUID LIMIT (%)	PLASTIC LIMIT (%)	ATTERBERG PLASTICITY INDEX (%)	MINUS #200 SIEVE (%)	OTHER TESTS PERFORMED (Page Ref. #)
22	25	25	25	25	
22	25	25	25	25	
24	21	21	21	21	
24	21	21	21	21	
24	21	21	21	21	
24	21	21	21	21	
24	21	21	21	21	
24	21	21	21	21	

Notes:
 GPS Coordinates: N 32° 15.723', W 94° 33.756'

Key to Abbreviations:
 N - SPT Data (Blows/Ft)
 P - Pocket Penetrometer (tsf)
 T - Torvane (tsf)
 L - Lab Vane Shear (tsf)



**ETTL
ENGINEERS &
CONSULTANTS**

MAIN OFFICE
1717 East Erwin
Tyler, Texas 75702
(903) 595-4421

MATERIAL DESCRIPTION

--with black lignite

--dark brown; with silt seams; with lignite seam

Bottom of Boring @ 100'

DEPTH (ft)
90
100
WATER LEVEL
USC
SAMPLES

Water Level Observations:
Water level @ 22' and open to 89' upon completion. Water level @ 26' and open to 27' on 10/9/08.

Est. Measured: Perched:
Water level @ 22' and open to 89' upon completion. Water level @ 26' and open to 27' on 10/9/08.

Key to Abbreviations:
N - SPT Data (Blow/ft)
P - Pocket Penetrometer (tsf)
T - Torvane (tsf)
L - Lab Vane Shear (tsf)

Notes:

GPS Coordinates: N 32° 15.723', W 94° 33.756'

LOG OF BORING B-14

PROJECT: Martin Lake - Luminant East Ash Disposal
Rusk County, Texas

PROJECT NO.: G 2972-08

BORING TYPE: Flight Auger

DATE

10/6/08

SURFACE ELEVATION

FIELD STRENGTH DATA	BLOW COUNT ● 20 40 60 80 ▲ Qu (tsf) ▲ 1 2 3 4	DRY DENSITY (pcf)	COMPRESSIVE STRENGTH (tsf)	FAILURE STRAIN (%)	CONFINING PRESSURE (psf)	Natural Moisture Content and Atterberg Limits		MOISTURE CONTENT (%)	OTHER TESTS PERFORMED (Page Ref. #)
						Plastic Limit	Liquid Limit		
N=50/3.5"	● 20 40 60 80 ▲ Qu (tsf) ▲ 1 2 3 4 ■ PPR (tsf) ■ 1.0 2.0 3.0 4.0 ◆ Torvane (tsf) ◆ 1.0 2.0 3.0 4.0								
N=50/6"									
N=88									

ATTERBERG LIMITS (%)

LIQUID LIMIT (LL)
PLASTIC LIMIT (PL)
PLASTICITY INDEX (PI)
MINUS #200 SIEVE (%)

DATE: 10/6/08



**ETTL
ENGINEERS &
CONSULTANTS**

MAIN OFFICE
1717 East Erwin
Tyler, Texas 75702
(903) 595-4421

WATER LEVEL

USC

SAMPLES

DEPTH (ft)

MATERIAL DESCRIPTION

SANDY LEAN CLAY (CL) very stiff, tan, red, and gray

-hard, red, tan, and gray; mottled

-with some gravel

-tan, red, and gray; mottled

-gray, red, and tan; mottled

SILTY SAND (SM) medium dense; red and gray; saturated

Bottom of Boring @ 40'

Water Level

Est

Measured

Perched

✓

Water Observations:

Seepage @ 32' while drilling. Water level @ 29' and open to 32' upon completion. Water level @ 25' and open to 25' on 10/9/08.

Key to Abbreviations:

N - SPT Data (Blows/Ft)

P - Pocket Penetrometer (tsf)

T - Torvane (tsf)

L - Lab Vane Shear (tsf)

Notes:

GPS Coordinates: N 32°15.860', W 94°33.890'

LOG OF BORING B-2

PROJECT: Martin Lake - Luminant East Ash Disposal
Rusk County, Texas

PROJECT NO.: G 2972-08

BORING TYPE: Flight Auger

DATE

10/8/08

SURFACE ELEVATION

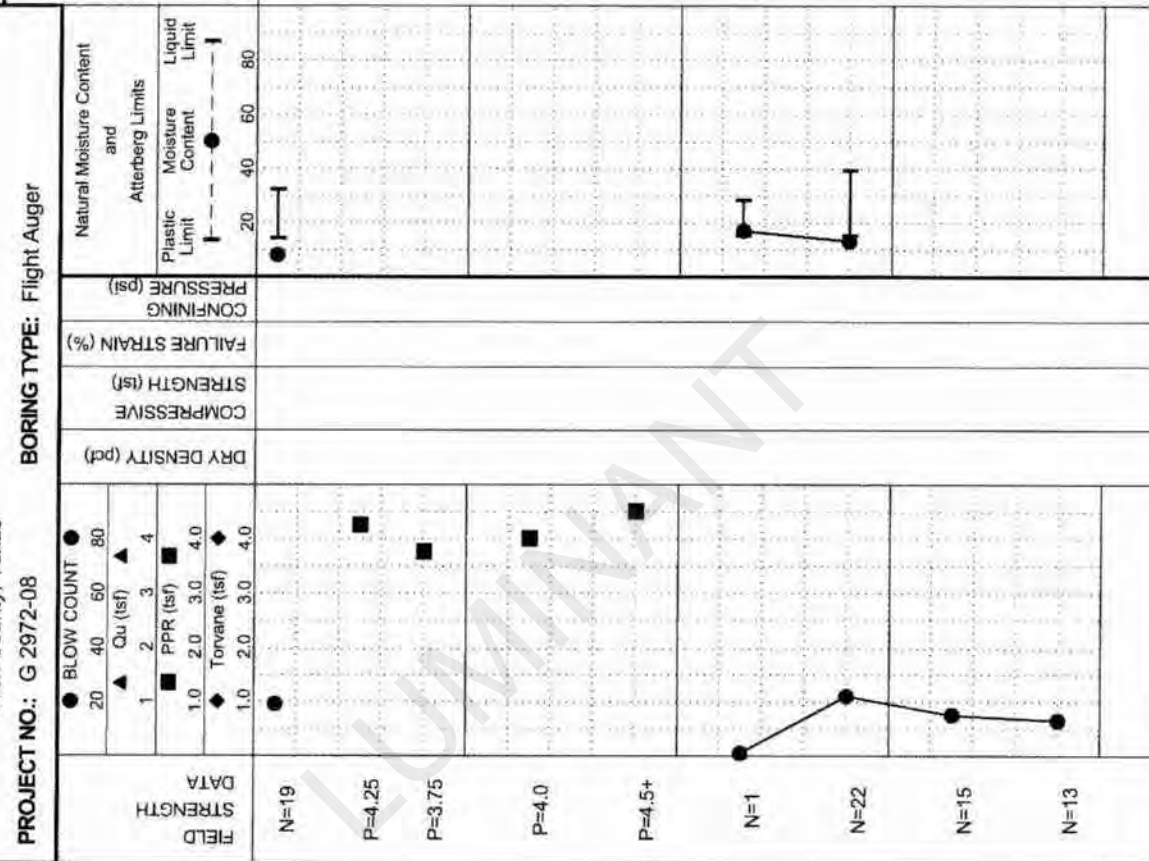

Water Level

Est

Measured

Perched

✓

Water Observations:

Seepage @ 32' while drilling. Water level @ 29' and open to 32' upon completion. Water level @ 25' and open to 25' on 10/9/08.

Key to Abbreviations:

N - SPT Data (Blows/Ft)

P - Pocket Penetrometer (tsf)

T - Torvane (tsf)

L - Lab Vane Shear (tsf)

Notes:

GPS Coordinates: N 32°15.860', W 94°33.890'



**ETTL
ENGINEERS &
CONSULTANTS**

MAIN OFFICE
1717 East Erwin
Tyler, Texas 75702
(903) 595-4421

MATERIAL DESCRIPTION

SANDY LEAN CLAY (CL) very stiff, tan, red, and gray, mottled

--stiff

CLAYEY SAND (SC) medium dense; red

--gray

LEAN CLAY WITH SAND (CL) stiff, red, tan, and gray, mottled

--with sand seams

CLAYEY SAND (SC) medium dense; gray and red; mottled; with clay seams

Bottom of Boring @ 40'

LOG OF BORING B-3

PROJECT: Martin Lake - Luminant East Ash Disposal
Rusk County, Texas

PROJECT NO.: G 2972-08

BORING TYPE: Flight Auger

DATE: 10/8/08

SURFACE ELEVATION

DEPTH (ft)	USC	WATER LEVEL	FIELD STRENGTH DATA	BLOW COUNT				DRY DENSITY (pcf)	COMPRESSIVE STRENGTH (tsf)	FAILURE STRAIN (%)	CONFINING PRESSURE (psi)	Natural Moisture Content and Atterberg Limits			MOISTURE CONTENT (%)	ATTEBERG LIMITS (%)	MINUS #200 SIEVE (%)	OTHER TESTS PERFORMED (Page Ref. #)
				BLOW COUNT	Qu (tsf)	PPR (tsf)	Torvane (tsf)					Plastic Limit	Moisture Content	Liquid Limit				
0	CL		P=3.5	1	2.5	1.0	3.5					20	33	13	20	68	+40 Sieve =1%, +4 Sieve =0%	
10			P=2.5	2	2.5	1.0	3.5					20	37	15	22	19	+40 Sieve =15%, +4 Sieve =7%	
20	SC		P=3.0	3	2.5	1.0	3.5					20	34	16	18	71	+40 Sieve =5%, +4 Sieve =0%	
30	CL		P=3.5	4	2.5	1.0	3.5					20	34	16	18	71	+40 Sieve =5%, +4 Sieve =0%	
40	SC		P=1.5	1	2.5	1.0	3.5					20	34	16	18	71	+40 Sieve =5%, +4 Sieve =0%	
			N=15	15	2.5	1.0	3.5					20	34	16	18	71	+40 Sieve =5%, +4 Sieve =0%	
			N=4	4	2.5	1.0	3.5					20	34	16	18	71	+40 Sieve =5%, +4 Sieve =0%	
			N=15	15	2.5	1.0	3.5					20	34	16	18	71	+40 Sieve =5%, +4 Sieve =0%	
			N=13	13	2.5	1.0	3.5					20	34	16	18	71	+40 Sieve =5%, +4 Sieve =0%	
			N=13	13	2.5	1.0	3.5					20	34	16	18	71	+40 Sieve =5%, +4 Sieve =0%	

Water Observations:
Seepage @ 29' while drilling. Water level @ 28' and open to 34' upon completion. Water level @ 25' and open to 32' on 10/9/08.

Est: Measured: Perched:

Water Level

Key to Abbreviations:
N - SPT Data (Blow/ft)
P - Pocket Penetrometer (tsf)
T - Torvane (tsf)
L - Lab Vane Shear (tsf)

Notes:
GPS Coordinates: N 32°15.876', W 94°33.842'

LOG OF BORING B-6

PROJECT: Martin Lake - Luminant East Ash Disposal
 Rusk County, Texas
PROJECT NO.: G 2972-08
BORING TYPE: Flight Auger

DATE: 10/7/08
SURFACE ELEVATION:

OTHER TESTS PERFORMED: (Page Ref. #)

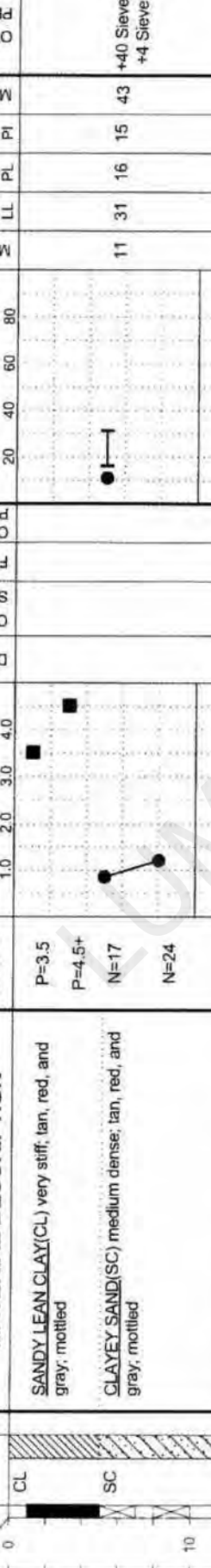

DEPTH (ft)	USC	FIELD STRENGTH DATA	BLOW COUNT	DRY DENSITY (pcf)	COMPRESSIVE STRENGTH (tsf)	FAILURE STRAIN (%)	CONFINING PRESSURE (psi)	Natural Moisture Content and Atterberg Limits	MOISTURE CONTENT (%)	ATTERBERG LIMITS (%)	MINUS #200 SIEVE (%)	OTHER TESTS PERFORMED (Page Ref. #)
0 - 3.5	CL	P=3.5	1.0, 2.0, 3.0, 4.0						11	LL 31, PL 16, PI 15	43	+40 Sieve =1%, +4 Sieve =0%
3.5 - 4.5	SC	P=4.5+	1.0, 2.0, 3.0, 4.0						19	LL 45, PL 16, PI 29	88	+40 Sieve =0%, +4 Sieve =0%
4.5 - 17	CL	N=17	1.0, 2.0, 3.0, 4.0						14	LL 46, PL 17, PI 29	74	+40 Sieve =0%, +4 Sieve =0%
17 - 24	CL	N=24	1.0, 2.0, 3.0, 4.0						18	LL 46, PL 17, PI 29	84	+40 Sieve =8%, +4 Sieve =3%
24 - 1.75	CL	P=1.75	1.0, 2.0, 3.0, 4.0									
1.75 - 3.25	CL	P=3.25	1.0, 2.0, 3.0, 4.0									
3.25 - 19	CL	N=19	1.0, 2.0, 3.0, 4.0									
19 - 25	CL	N=25	1.0, 2.0, 3.0, 4.0									
25 - 18	CL	N=18	1.0, 2.0, 3.0, 4.0									
18 - 18	CL	N=18	1.0, 2.0, 3.0, 4.0									

MATERIAL DESCRIPTION

SANDY LEAN CLAY (CL) very stiff, tan, red, and gray; mottled

CLAYEY SAND (SC) medium dense; tan, red, and gray; mottled

LEAN CLAY (CL) stiff, tan, red, and gray; mottled

-very stiff, brown, gray, and red; with sand; trace ferric material and lignite

-with sand seams

-tan, red, and gray; mottled

-tan and gray; mottled

SILTY SAND (SM) tan and gray

SANDY LEAN CLAY (CL) very stiff, tan and gray

Bottom of Boring @ 40'

Water Level: Measured: Perched:

Water Observations: Seepage @ 28' while drilling. Water level @ 26' and open to 34' upon completion. Water level @ 25' and open to 27' on 10/8/08.

Notes: GPS Coordinates: N 32°15.833', W 94°33.814'

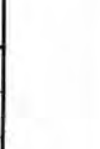

ETTL ENGINEERS & CONSULTANTS

MAIN OFFICE
 1717 East Erwin
 Tyler, Texas 75702
 (903) 595-4421



**ETTL
ENGINEERS &
CONSULTANTS**

MAIN OFFICE
1717 East Erwin
Tyler, Texas 75702
(903) 595-4421

MATERIAL DESCRIPTION

SANDY LEAN CLAY (CL) hard; tan, red, and gray; mottled
 SANDY SILTY CLAY (CL-ML) very stiff; tan, red, and gray; mottled
 LEAN CLAY WITH SAND (CL) very stiff; tan, red, and gray; mottled
 -stiff
 FAT CLAY (CH) stiff, gray, red, and tan; mottled
 SILTY SAND (SM) medium dense; tan, red, gray, mottled
 SANDY LEAN CLAY (CL) very stiff; red, tan, and gray; mottled

Bottom of Boring @ 40'

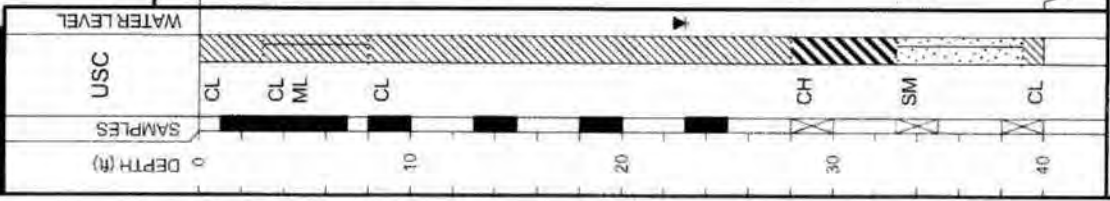

LOG OF BORING B-7
 PROJECT: Martin Lake - Luminant East Ash Disposal
 Rusk County, Texas
 PROJECT NO.: G 2972-08
 BORING TYPE: Flight Auger

FIELD STRENGTH DATA	BLOW COUNT 20 40 60 80 ▲ Qu (tsf) ▲ 1 2 3 4 ■ PPR (tsf) ■ ◆ Torvane (tsf) ◆	DRY DENSITY (pcf)	COMPRESSIONIVE STRENGTH (tsf)	FAILURE STRAIN (%)	CONFINING PRESSURE (psi)	Natural Moisture Content and Atterberg Limits		MOISTURE CONTENT (%)	ATTERBERG LIMITS (%)	MINUS #200 SIEVE (%)	OTHER TESTS PERFORMED (Page Ref. #)
						Plastic Limit	Liquid Limit				
P=4.0	■					20	30	16	LL 21, PL 14, PI 7	63	+40 Sieve =0%, +4 Sieve =0%
P=3.0	■					20	30	15	LL 34, PL 16, PI 18	74	+40 Sieve =1%, +4 Sieve =0%
P=3.0	■					20	30	15	LL 36, PL 15, PI 21	72	+40 Sieve =0%, +4 Sieve =0%
P=3.25	■					20	30	25	LL 55, PL 19, PI 36	88	+40 Sieve =1%, +4 Sieve =0%
P=1.5	■					20	30				
P=1.5	■					20	30				
N=11	●					20	30				
N=10	●					20	30				
N=20	●					20	30				

DATE: 10/8/08
 SURFACE ELEVATION:
 Notes:
 Key to Abbreviations:
 N - SFT Data (Blows/Ft)
 P - Pocket Penetrometer (tsf)
 T - Torvane (tsf)
 L - Lab Vane Shear (tsf)
 GPS Coordinates: N 32° 15.775', W 94° 33.875'



**ETTL
ENGINEERS &
CONSULTANTS**

MAIN OFFICE
1717 East Erwin
Tyler, Texas 75702
(903) 595-4421

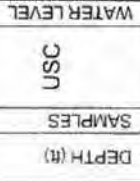

MATERIAL DESCRIPTION

SANDY LEAN CLAY (CL) hard; tan, red, and gray; mottled

-very stiff

-red and gray; mottled

SILTY SAND (SM) dense; red, tan, and reddish gray; mottled; saturated

Bottom of Boring @ 40'

Water Observations:
@ 35' and open to 36' upon completion. Water level @ 23' and open to 27' on 10/8/08.

Est: Measured: Perched:
Seepage @ 38' while drilling. Water level @ 35' and open to 36' upon completion. Water level @ 23' and open to 27' on 10/8/08.

LOG OF BORING B-8											
PROJECT: Martin Lake - Luminant East Ash Disposal Rusk County, Texas											
PROJECT NO.: G 2972-08											
BORING TYPE: Flight Auger											
DATE: 10/7/08											
SURFACE ELEVATION											
DEPTH (ft)	FIELD STRENGTH	BLOW COUNT		DRY DENSITY (pcf)	COMPRESSIVE STRENGTH (tsf)	FAILURE STRAIN (%)	CONFINING PRESSURE (psi)	Afterberg Limits		OTHER TESTS PERFORMED (Page Ref. #)	
		BLOW COUNT	Qu (tsf)					PLASTIC LIMIT	LIQUID LIMIT		
		1	2	3	4			LL	PL	PI	
0 - 4.5	P=4.5+	1	2	3	4			30	13	17	+40 Sieve =2%, +4 Sieve =0%
4.5 - 3.5	P=4.5+	1	2	3	4			29	13	16	+40 Sieve =0%, +4 Sieve =0%
3.5 - 4.0	P=3.5	1	2	3	4			44	18	26	+40 Sieve =3%, +4 Sieve =0%
4.0 - 3.5	P=4.0	1	2	3	4			36	16	20	+40 Sieve =9%, +4 Sieve =3%
3.5 - 15	P=3.5	1	2	3	4						
15 - 2.5	N=15	1	2	3	4						
2.5 - 15	P=2.5	1	2	3	4						
15 - 16	N=15	1	2	3	4						
16 - 26	N=16	1	2	3	4						
26 - 40	N=26	1	2	3	4						

Notes:
GPS Coordinates: N 32° 15.803', W 94° 33.798'

Key to Abbreviations:
N - SPT Data (Blows/Ft)
P - Pocket Penetrometer (tsf)
T - Torvane (tsf)
L - Lub Vane Shear (tsf)



**ETTL
ENGINEERS &
CONSULTANTS**

MAIN OFFICE
1717 East Erwin
Tyler, Texas 75702
(903) 595-4421

LOG OF BORING B-9
PROJECT: Martin Lake - Luminant East Ash Disposal
Rusk County, Texas
BORING TYPE: Flight Auger
PROJECT NO.: G 2972-08
DATE: 10/9/08
SURFACE ELEVATION

DEPTH (ft)	SAMPLES	USC	WATER LEVEL	FIELD STRENGTH DATA	BLOW COUNT 20 40 60 80 ▲ Ou (tsf) ▲ 1 2 3 4 ■ PPR (tsf) ■ 1.0 2.0 3.0 4.0 ◆ Torvane (tsf) ◆	DRY DENSITY (pcf)	COMPRESSIONIVE STRENGTH (tsf)	FAILURE STRAIN (%)	CONFINING PRESSURE (psi)	Natural Moisture Content and Atterberg Limits		MOISTURE CONTENT (%)	ATTERBERG LIMITS (%)			OTHER TESTS PERFORMED (Page Ref. #)
										Plastic Limit	Liquid Limit		PL	PL	PI	
0																
0-10		CL		P=4.5+ P=4.5 P=2.5 P=3.25	●						14	29	14	15	59	+40 Sieve =2%, +4 Sieve =0%
10-20				SF	●						14	36	15	21	58	+40 Sieve =1%, +4 Sieve =0%
20-30				P=2.5	●						13	38	14	24	56	+40 Sieve =1%, +4 Sieve =0%
30-40				N=16 N=23 N=14 N=23	●											
40																

Notes:
GPS Coordinates: N 32°15.745', W 94°33.857'

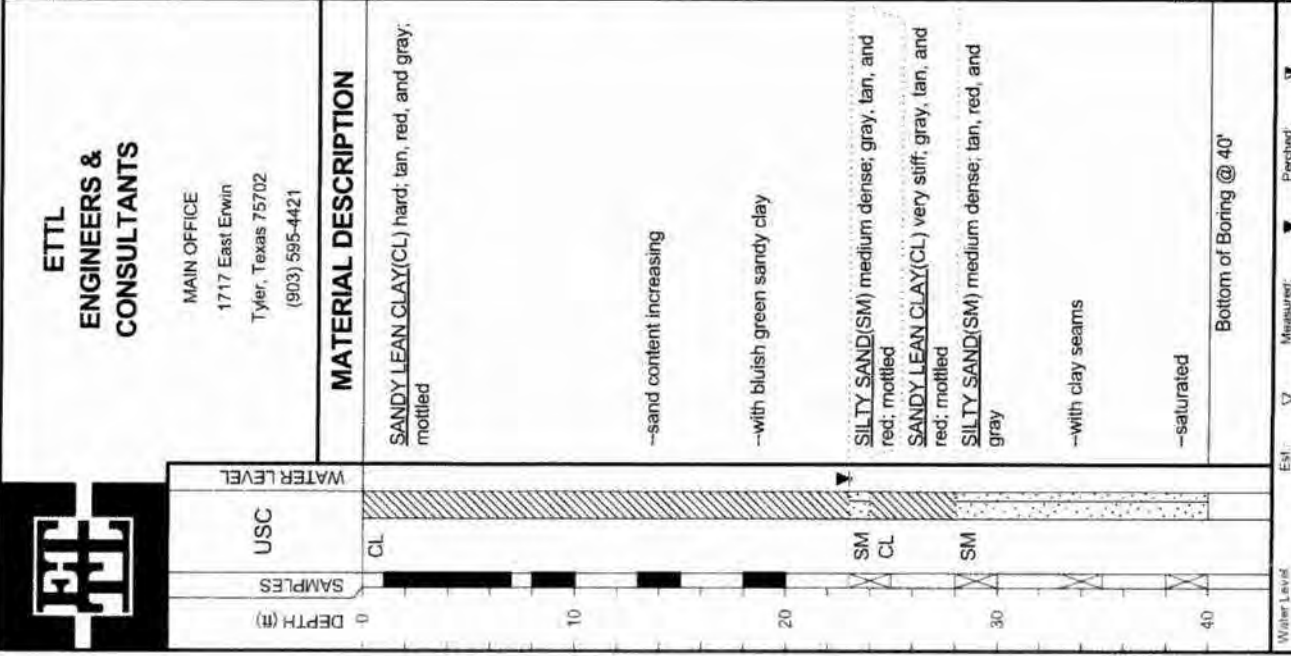

Key to Abbreviations:
N - SPT Data (Blows/Ft)
P - Pocket Penetrometer (tsf)
T - Torvane (tsf)
L - Lab Vane Shear (tsf)

Water Observations:
Seepage @ 28' while drilling. Water level @ 23' and open to 31' upon completion. Water level @ 23' and open to 29' on 10/10/08.

Est: [] Measured: [] Perched: []

PERMANENT DISPOSAL POND - 5

LUMINANT

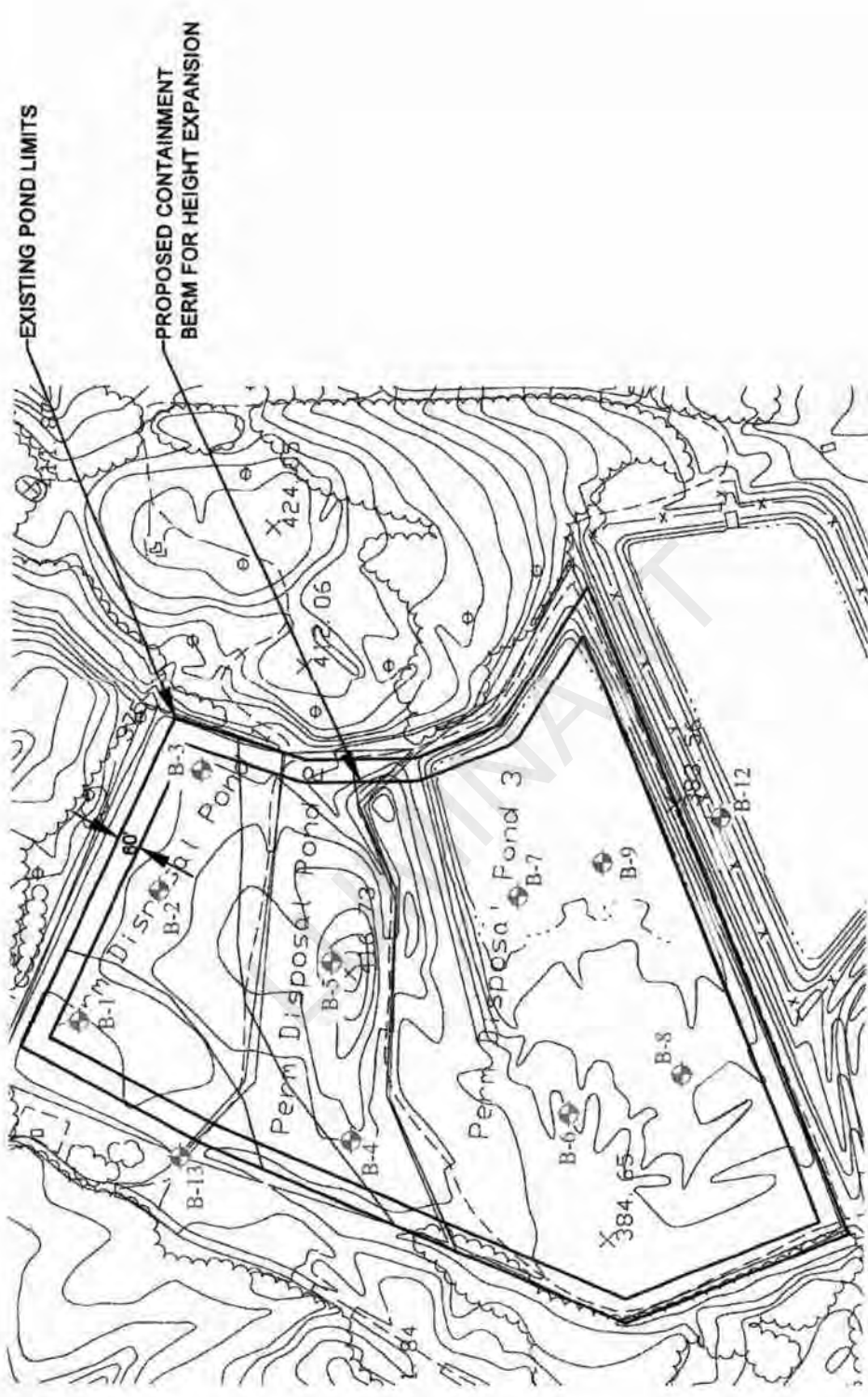

 ETTL ENGINEERS & CONSULTANTS <small>1000 West 10th Street Suite 200 Fort Worth, TX 76102</small>	LUMINANT MARTIN LAKE PDP 1-3 TATUM, TEXAS	PLATE 1 - PLAN OF BORINGS	APPROVED BY:
	DATE: MARCH 2008	SCALE: N.T.S.	DRAIN BY: K.C.R.



**ETTL
ENGINEERS &
CONSULTANTS**

MAIN OFFICE
1717 East Erwin
Tyler, Texas 75702
(903) 595-4421

MATERIAL DESCRIPTION

SILTY SAND(SM) loose; tan; moist; with ferric oxide; with organics
ASH SEDIMENT medium dense; black and gray; coarse to very fine-grained sand
-black
-loose; black and gray; coarse to very fine-grained sand

Bottom of Boring @ 20'

Water Level
Water Observations:
1' and caved to 6' on 2/29/08.

Est: Measured: Perched:
Seepage @ 7' while drilling. Water level @ 1' and caved to 6' on 2/29/08.

FIELD STRENGTH DATA		BLOW COUNT		DRY DENSITY (pcf)		COMPRESSIONIVE STRENGTH (tsf)		FAILURE STRAIN (%)		CONFINING PRESSURE (psi)		Natural Moisture Content and Atterberg Limits		MOISTURE CONTENT (%)		ATTERBERG LIMITS(%)		MINUS #200 SIEVE (%)		OTHER TESTS	
FIELD STRENGTH	DATA	BLOW COUNT	Qu (tsf)	PPR (tsf)	Torvane (tsf)	COMPRESSIONIVE STRENGTH (tsf)	FAILURE STRAIN (%)	CONFINING PRESSURE (psi)	Plastic Limit	Liquid Limit	MOISTURE CONTENT (%)	LL	PL	PI	MOISTURE CONTENT (%)	PL	PI	MINUS #200 SIEVE (%)	OTHER TESTS		
N=5		1	1.0	1.0	1.0				20	20	17	16	14	2	34			34	+40 Sieve =8%, +4 Sieve =3%		
N=22		2	2.0	2.0	2.0	101			20	20	23	23			23			23	+40 Sieve =55%, +4 Sieve =26%		
N=17		3	3.0	3.0	3.0	82			20	20	28	28			36			53			
N=8		4	4.0	4.0	4.0				20	20	32	32									
N=9																					

Key to Abbreviations:
N - SPT Data (Blows/Ft)
P - Pocket Penetrometer (tsf)
T - Torvane (tsf)
L - Lab Vane Shear (tsf)

Notes:
GPS Coordinates: N 32°15.790', W 94°34.996'. Minus #200 Sieve (53%) @ 18' (Hydrometer - Specific Gravity 2.608). Dry Density (82) @ 8' (Hydraulic Conductivity K=2.79E-04 cm/sec).

LOG OF BORING B-1

PROJECT: Luminant Martin Lake PDP 1-3
Tatum, Texas

PROJECT NO.: G 2810-08
BORING TYPE: Flight Auger

DATE: 2/22/08

SURFACE ELEVATION: 390'

(Page Ref. #)
PERFORMED



**ETTL
ENGINEERS &
CONSULTANTS**

MAIN OFFICE
1717 East Erwin
Tyler, Texas 75702
(903) 595-4421

MATERIAL DESCRIPTION

CLAYEY SAND(SC) medium dense; red and orange
 -loose; gray, red, and orange
 LEAN CLAY WITH SAND(CL) stiff; red, orange, and tan
 -gray and red
 -red and orange
 CLAYEY SAND(SC) medium dense; red and orange
 -with iron oxide cemented sandstone gravel
 SILTY SAND(SM) medium dense; gray, red, and orange
 SANDY LEAN CLAY(CL) medium dense; red, orange, and gray
 -red and orange; with iron oxide cemented sandstone seam @ 45'
 SILTY SAND(SM) medium dense; gray, orange, and tan

Est.: Measured: Priced:

Dry and open to 25' on 2/29/08.

Water Observations:

Water Level

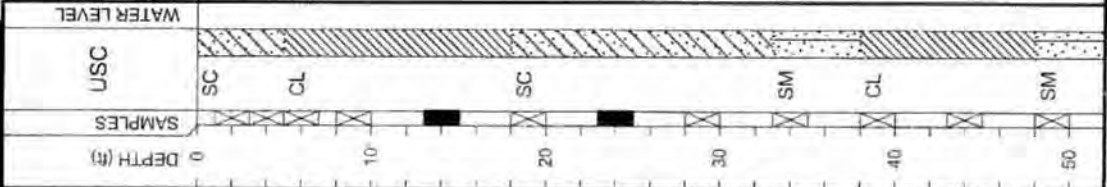

LOG OF BORING B-12

PROJECT: Luminant Martin Lake PDP 1-3
Tatum, Texas

PROJECT NO.: G 2810-08

BORING TYPE: Rotary Wash

DATE: 2/27/08

SURFACE ELEVATION
380'

MOISTURE CONTENT (%)		ATTERBERG LIMITS (%)		MINUS #200 SIEVE (%)	OTHER TESTS PERFORMED (Page Ref. #)
LIQUID LIMIT (LL)	PLASTIC LIMIT (PL)	LIQUID LIMIT (LL)	PLASTICITY INDEX (PI)		
16	35	15	20	37	+40 Sieve =10%, +4 Sieve =3%
24	47	19	28	79	+40 Sieve =3%, +4 Sieve =0%
17	36	15	21	44	+40 Sieve =21%, +4 Sieve =18%
20	40	16	24	61	+40 Sieve =5%, +4 Sieve =3%

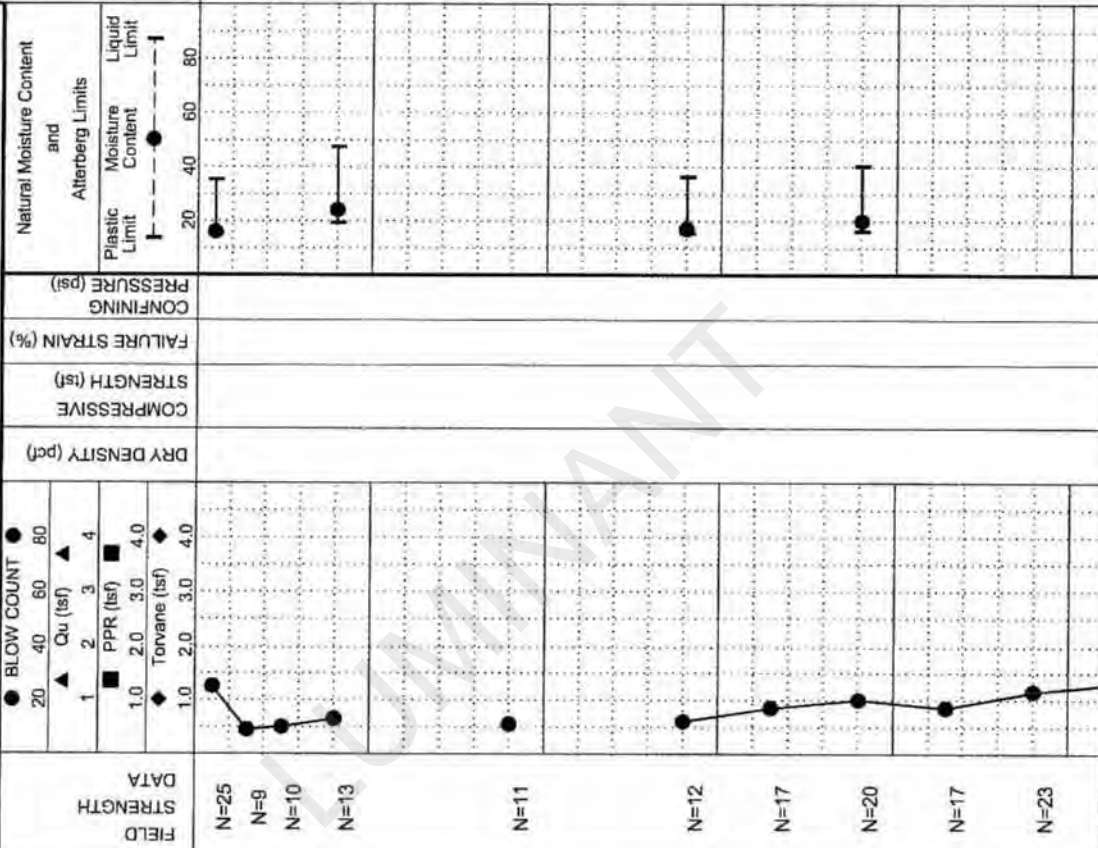

Key to Abbreviations:

- N - SPT Data (Blows/Ft)
- P - Pocket Penetrometer (tsf)
- T - Torvane (tsf)
- L - Lab Vane Shear (tsf)

Notes:

GPS Coordinates: N 32°15.513', W 94°34.904'



**ETTL
ENGINEERS &
CONSULTANTS**

MAIN OFFICE
1717 East Erwin
Tyler, Texas 75702
(803) 595-4421

MATERIAL DESCRIPTION

-gray, red, brown
-gray and brown
SILT(ML) dense; brown and gray
-very dense
LEAN CLAY WITH SAND(CL) hard, gray
SILT(ML) very dense; gray

Bottom of Boring @ 100'

WATER LEVEL
USC
SAMPLES
DEPTH (ft)

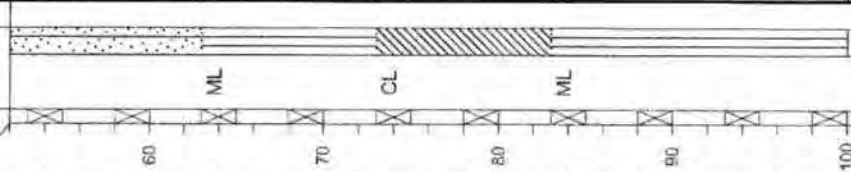

Est: Measured: Perched:
Dry and open to 25' on 2/29/08.

Water Level
Water Observations:

LOG OF BORING B-12

PROJECT: Luminant Martin Lake PDP 1-3
Tatum, Texas

PROJECT NO.: G 2810-08

BORING TYPE: Rotary Wash

DATE

2/27/08

SURFACE ELEVATION
380'

MOISTURE CONTENT (%)

LIQUID LIMIT

PLASTIC LIMIT

PLASTICITY INDEX

MINUS #200 SIEVE (%)

OTHER TESTS

(Page Ref. #)

NATURAL MOISTURE CONTENT
and
Atterberg Limits

PLASTIC LIMIT

LIQUID LIMIT

PLASTICITY INDEX

MINUS #200 SIEVE (%)

OTHER TESTS

(Page Ref. #)

COMPRESSIVE
STRENGTH (tsf)

FAILURE STRAIN (%)

CONFINING
PRESSURE (psi)

DRY DENSITY (pcf)

FIELD
STRENGTH

N=26

N=28

N=46

N=66

N=50/3"

N=50/4"

N=71

N=50/5"

N=70

N=80

DATA

BLOW COUNT

Qu (tsf)

PPR (tsf)

Torvane (tsf)

99

102

107

99

102

107

99

102

107

99

102

107

99

102

107

99

102

107

99

102

107

99

102

107

99

102

107

99

102

107

99

102

107

Key to Abbreviations:
N - SPT Data (Blows/ft)
P - Pocket Penetrometer (tsf)
T - Torvane (tsf)
L - Lab Vane Shear (tsf)

Notes:

GPS Coordinates: N 32°15.513', W 94°34.904'



**ETTL
ENGINEERS &
CONSULTANTS**

MAIN OFFICE
1717 East Erwin
Tyler, Texas 75702
(903) 595-4421

MATERIAL DESCRIPTION

CLAYEY SAND(SC) medium dense; red

-brown and gray
-dense; red and tan

-tan, red, and gray

FAT CLAY(CH) stiff; red, gray, and tan

-with iron laminations

LEAN CLAY(CL) very stiff; gray

-hard

-gray and brown; with iron oxide cemented sandstone seams

SANDY SILT(ML) very dense; gray; with clay seams

WATER LEVEL

USC

SAMPLES

DEPTH (ft)

0

10

20

30

40

50

Water Level

Water Observations

Seepage @ 29' while drilling. Water level @ 28' and open upon completion. Water level @ 12' and caved to 14' on 2/29/08.

Est. Measured: Perched:

Key to Abbreviations:

- N - SPT Data (Blows/Ft)
- P - Pocket Penetrometer (tsf)
- T - Torvane (tsf)
- L - Lab Vane Shear (tsf)

Notes:

GPS Coordinates: N 32°15.752', W 94°35.072'.

LOG OF BORING B-13

PROJECT: Luminant Martin Lake PDP 1-3
Tatum, Texas

PROJECT NO.: G 2810-08

BORING TYPE: Rotary Wash

DATE

2/19/08

SURFACE ELEVATION
380'

OTHER TESTS
PERFORMED
(Page Ref. #)

MOISTURE CONTENT (%)

LL

PL

PI

MINUS #200 SIEVE (%)

Natural Moisture Content

Plastic Limit

Moisture Content

Liquid Limit

Atterberg Limits

DRY DENSITY (pcf)

COMPRESSIVE STRENGTH (tsf)

FAILURE STRAIN (%)

CONFINING PRESSURE (psi)

Natural Moisture Content

Atterberg Limits

Plastic Limit

Moisture Content

Liquid Limit

Atterberg Limits

Plastic Limit

Moisture Content

Liquid Limit

Atterberg Limits

Plastic Limit

Moisture Content

Liquid Limit

Atterberg Limits

Plastic Limit

Moisture Content

Liquid Limit

Atterberg Limits

Plastic Limit

Moisture Content

Liquid Limit

Atterberg Limits

Plastic Limit

Moisture Content

Liquid Limit

Atterberg Limits

Plastic Limit

Moisture Content

Liquid Limit

Atterberg Limits

Plastic Limit

Moisture Content

Liquid Limit

Atterberg Limits

Plastic Limit

Moisture Content

Liquid Limit

Atterberg Limits

Plastic Limit

FIELD STRENGTH

N=11

N=16

N=38

N=47

N=37

P=1.5

P=1.5

P=1.5

N=26

P=4.5+

P=4.5+

N=63

N=63

BLOW COUNT

Qu (tsf)

PPR (tsf)

Torvane (tsf)

20

40

60

80

1

2

3

4

1.0

2.0

3.0

4.0

1.0

2.0

3.0

4.0

1.0

2.0

3.0

4.0

1.0

2.0

3.0

4.0

1.0

2.0

3.0

4.0

1.0

2.0

3.0

4.0

1.0

2.0

3.0

4.0

1.0

2.0

3.0

COMPRESSIVE STRENGTH (tsf)

FAILURE STRAIN (%)

CONFINING PRESSURE (psi)

Natural Moisture Content

Plastic Limit

Moisture Content

Liquid Limit

Atterberg Limits

Plastic Limit

Moisture Content

Liquid Limit

Atterberg Limits

Plastic Limit

Moisture Content

Liquid Limit

Atterberg Limits

Plastic Limit

Moisture Content

Liquid Limit

Atterberg Limits

Plastic Limit

Moisture Content

Liquid Limit

Atterberg Limits

Plastic Limit

Moisture Content

Liquid Limit

Atterberg Limits

Plastic Limit

Moisture Content

Liquid Limit

Atterberg Limits

Plastic Limit

Moisture Content

Liquid Limit

Atterberg Limits

Plastic Limit

Moisture Content

Liquid Limit

Atterberg Limits

Plastic Limit

Moisture Content

Liquid Limit

Atterberg Limits

Plastic Limit

Moisture Content

Liquid Limit

MOISTURE CONTENT (%)

LL

PL

PI

MINUS #200 SIEVE (%)

OTHER TESTS
PERFORMED
(Page Ref. #)

+40 Sieve =3%,
+4 Sieve =1%

+40 Sieve =7%,
+4 Sieve =1%

+40 Sieve =2%,
+4 Sieve =0%

+40 Sieve =2%,
+4 Sieve =0%

+40 Sieve =3%,
+4 Sieve =1%

+40 Sieve =7%,
+4 Sieve =1%

+40 Sieve =2%,
+4 Sieve =0%

+40 Sieve =2%,
+4 Sieve =0%

+40 Sieve =3%,
+4 Sieve =1%

+40 Sieve =7%,
+4 Sieve =1%

+40 Sieve =2%,
+4 Sieve =0%

+40 Sieve =2%,
+4 Sieve =0%

+40 Sieve =3%,
+4 Sieve =1%

+40 Sieve =7%,
+4 Sieve =1%

+40 Sieve =2%,
+4 Sieve =0%

+40 Sieve =2%,
+4 Sieve =0%

+40 Sieve =3%,
+4 Sieve =1%



**ETTL
ENGINEERS &
CONSULTANTS**

MAIN OFFICE
1717 East Erwin
Tyler, Texas 75702
(903) 595-4421

MATERIAL DESCRIPTION

—hard; laminated with sand seams
 —very stiff; gray and green; with sand seams
 LEAN CLAY (CL) hard; gray; laminated with sand seams
 SILTY SAND (SM) very dense; gray
 SILT (ML) very dense; gray
 —with clay seams
 Bottom of Boring @ 100'

WATER LEVEL
 USC
 SAMPLES
 DEPTH (ft)

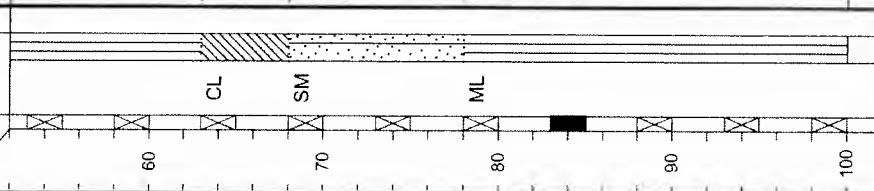

LOG OF BORING B-13

PROJECT: Luminant Martin Lake PDP 1-3
Tatum, Texas

PROJECT NO.: G 2810-08

BORING TYPE: Rotary Wash

DATE

2/19/08

SURFACE ELEVATION
380'

ATTERBERG
LIMITS(%)

LIQUID LIMIT

PLASTIC LIMIT

PLASTICITY INDEX

MINUS #200 SIEVE (%)

OTHER TESTS
PERFORMED
(Page Ref #)

26 47 23 96
 +40 Sieve =2%,
 +4 Sieve =0%

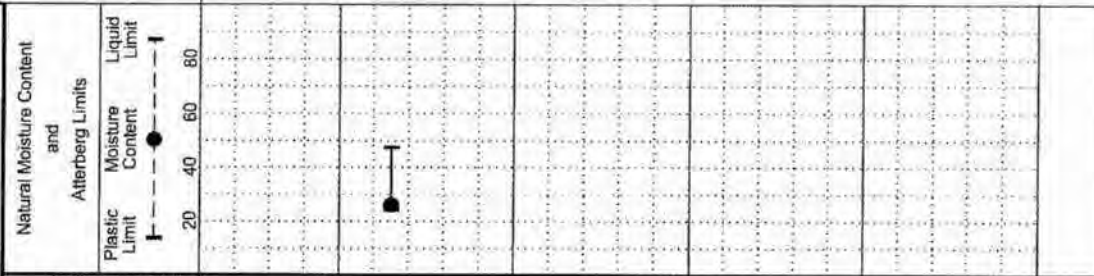

COMPRESSION
STRENGTH (tsf)
 FAILURE STRAIN (%)
 CONFINING PRESSURE (psi)

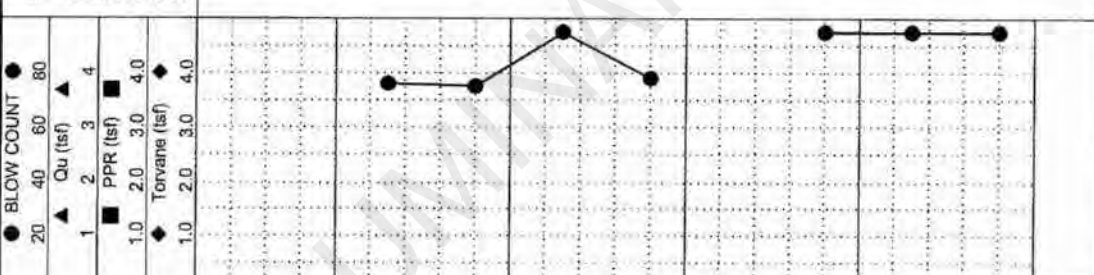

FIELD STRENGTH DATA
 BLOW COUNT
 Qu (tsf)
 PPR (tsf)
 Torvane (tsf)

Key to Abbreviations:
 N - SPT Data (Blows/FT)
 P - Pocket Penetrometer (tsf)
 T - Torvane (tsf)
 L - Lab Vane Shear (tsf)

Notes:
 GPS Coordinates: N 32° 15.752', W 94° 35.072'.

Est. Measured Perched:
 Seepage @ 29' while drilling. Water level @ 28' and open upon completion. Water level @ 12' and caved to 14' on 2/29/08.
 Water Level Observations:
 Water Level



**ETTL
ENGINEERS &
CONSULTANTS**

MAIN OFFICE
1717 East Erwin
Tyler, Texas 75702
(903) 595-4421

MATERIAL DESCRIPTION

SANDY FAT CLAY(CH) stiff; red and orange

-with sand

ASH SEDIMENT medium dense; black

-very loose; with organic odor

-light gray

Bottom of Boring @ 25'

USC
SAMPLES
DEPTH (ft)

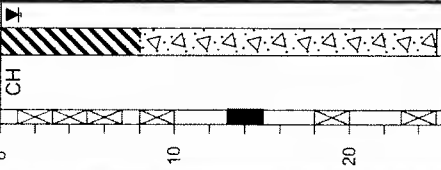

Water Level
Water Observations:
@ 1' and caved to 8' on 2/29/08.

Est. Measured: Perched:
Seepage @ 13' while drilling. Water level

DATE		SURFACE ELEVATION		BORING TYPE: Flight Auger		PROJECT: Luminant Martin Lake PDP 1-3 Tatum, Texas		PROJECT NO.: G 2810-08		GPS Coordinates: N 32°15.764'; W 94°34.903'. Minus #200 Sieve (93%) @ 23' (Hydrometer - Specific Gravity 2.675).	
DATE		SURFACE ELEVATION		BORING TYPE: Flight Auger		PROJECT: Luminant Martin Lake PDP 1-3 Tatum, Texas		PROJECT NO.: G 2810-08		GPS Coordinates: N 32°15.764'; W 94°34.903'. Minus #200 Sieve (93%) @ 23' (Hydrometer - Specific Gravity 2.675).	
DATE		SURFACE ELEVATION		BORING TYPE: Flight Auger		PROJECT: Luminant Martin Lake PDP 1-3 Tatum, Texas		PROJECT NO.: G 2810-08		GPS Coordinates: N 32°15.764'; W 94°34.903'. Minus #200 Sieve (93%) @ 23' (Hydrometer - Specific Gravity 2.675).	
MOISTURE CONTENT (%)	LL	PL	PI	MINUS #200 SIEVE (%)	OTHER TESTS PERFORMED (Page Ref. #)	FIELD STRENGTH	BLOW COUNT	COMPRESSIVE STRENGTH (tsf)	FAILURE STRAIN (%)	CONFINING PRESSURE (psi)	Natural Moisture Content and Atterberg Limits
22	51	18	33	65	+40 Sieve =9%, +4 Sieve =6%	N=11	▲ Qu (tsf) ▲ 1 2 3 4				Plastic Limit Moisture Content Liquid Limit
23	57	17	40	78	+40 Sieve =2%, +4 Sieve =0% +40 Sieve =63%, +4 Sieve =40%	N=11	■ PPR (tsf) ■ 1.0 2.0 3.0 4.0				
28	57	17	40	16	+40 Sieve =63%, +4 Sieve =40%	N=12	◆ Torvane (tsf) ◆ 1.0 2.0 3.0 4.0				
29						N=11					
30						N=3					
42											

Key to Abbreviations:
N - SPT Data (Blows/FT)
P - Pocket Penetrometer (tsf)
T - Torvane (tsf)
L - Lab Vane Shear (tsf)

Notes:
GPS Coordinates: N 32°15.764'; W 94°34.903'. Minus #200 Sieve (93%) @ 23' (Hydrometer - Specific Gravity 2.675).



**ETTL
ENGINEERS &
CONSULTANTS**

MAIN OFFICE
1717 East Erwin
Tyler, Texas 75702
(903) 595-4421

MATERIAL DESCRIPTION

SANDY FAT CLAY(CH) medium stiff, red and orange -stiff
ASH SEDIMENT dense; black
-medium dense; black and gray, coarse-grained sand
-very loose; black; coarse to fine-grained sand
-no recovery
-loose, light gray
-medium dense; black; with organic odor
Bottom of Boring @ 30'

WATER LEVEL
USC
SAMPLES
DEPTH (ft)

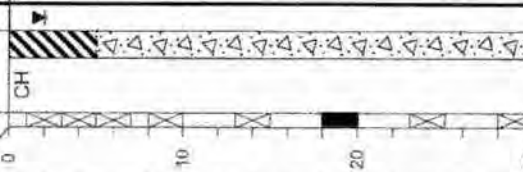

Water Level
Water Observed/USC
2' and caved to 8' on 2/29/08..

Est: Measured: Perched:
Seepage @ 8' while drilling. Water level @ 2' and caved to 8' on 2/29/08..

LOG OF BORING B-3

PROJECT: Luminant Martin Lake PDP 1-3
Tatum, Texas

PROJECT NO.: G 2810-08

BORING TYPE: Flight Auger

DATE

2/22/08

SURFACE ELEVATION
390'

MOISTURE CONTENT (%)	ATTERBERG LIMITS(%)			MINUS #200 SIEVE (%)	OTHER TESTS PERFORMED (Page Ref #)
	LL	PL	PI		
21	54	19	35	69	+40 Sieve =5%, +4 Sieve =1%
26				42	
26				10	+40 Sieve =60%, +4 Sieve =10%
28				9	+40 Sieve =67%, +4 Sieve =35%
69	49	41	8	100	+40 Sieve =0%, +4 Sieve =0%

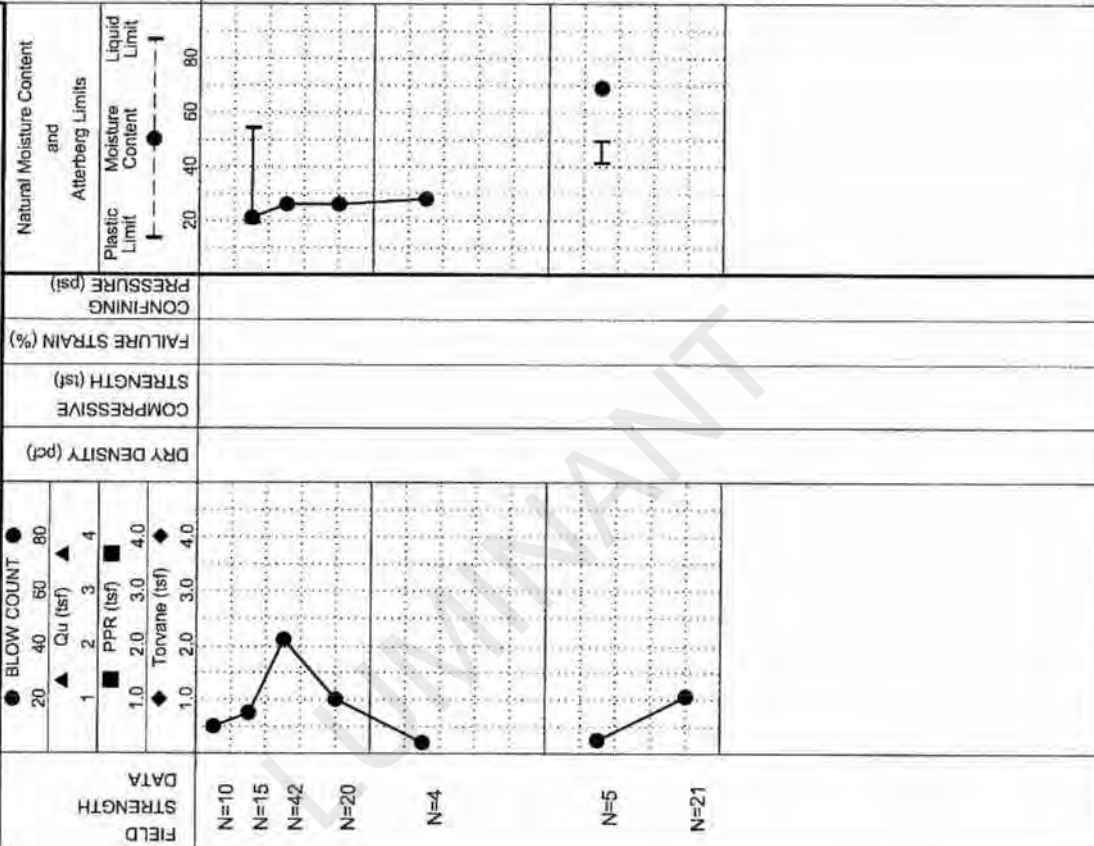

FIELD STRENGTH DATA
N=10
N=15
N=42
N=20
N=4
N=5
N=21

Key to Abbreviations:
N - SPT Data (Blows/Ft)
P - Pocket Penetrometer (tsf)
T - Torvane (tsf)
L - Lab Vane Shear (tsf)

Notes:
GPS Coordinates: N 32°15.746', W 94°34.855'. Minus #200 Sieve (42%) @ 5' (Hydrometer - Specific Gravity 2.561).



**ETTL
ENGINEERS &
CONSULTANTS**

MAIN OFFICE
1717 East Erwin
Tyler, Texas 75702
(903) 585-4421

MATERIAL DESCRIPTION

SILTY CLAYEY SAND(SC-SM) medium dense;
red and brown
-very stiff; red and orange
SILTY SAND(SM) medium dense; red and tan
LEAN CLAY(CL) very stiff; red, orange, and tan

-red, tan, and gray

Bottom of Boring @ 20'

WATER LEVEL

SAMPLES

DEPTH (ft)

USC

SC

SM

SM

CL

LOG OF BORING B-4

PROJECT: Luminant Martin Lake PDP 1-3
Tatum, Texas

PROJECT NO.: G 2810-08

BORING TYPE: Flight Auger

DATE

2/22/08

SURFACE ELEVATION
385'

MOISTURE CONTENT (%)
ATTERBERG LIMITS(%)
LIQUID LIMIT
PLASTIC LIMIT
PLASTICITY INDEX
MINUS #200 SIEVE (%)
OTHER TESTS
(Page Ref. #)

FIELD STRENGTH DATA	BLOW COUNT ● 20 40 60 80 ▲ Qu (tsf) ▲ 1 2 3 4 ■ PPR (tsf) 1.0 2.0 3.0 4.0 ◆ Torvane (tsf) 1.0 2.0 3.0 4.0	DRY DENSITY (pcf)	COMPRESSIVE STRENGTH (tsf)	FAILURE STRAIN (%)	CONFINING PRESSURE (psf)	Natural Moisture Content and Atterberg Limits Plastic Limit Liquid Limit
N=14						
N=21						
N=22						
N=18						
P=3.5		99	2.40	10	13	
N=25						
						15
						18
						22
						21
						20
						35
						14
						6
						42
						85
						17
						18
						21
						39
						18
						81
						+40 Sieve =1%, +4 Sieve =0%
						+40 Sieve =5%, +4 Sieve =1%
						+40 Sieve =0%, +4 Sieve =0%

Key to Abbreviations:

- N - SPT Data (Blows/ft)
- P - Pocket Penetrometer (tsf)
- T - Torvane (tsf)
- L - Lab Vane Shear (tsf)

Notes:

GPS Coordinates: N 32° 15.675', W 94° 35.083'

Water Level

Water Observations

Surface and caved to 15' on 2/29/08.

Est. Measured: Perched:

Seepage @ 3' while drilling. Water level @

Surface and caved to 15' on 2/29/08.



**EITL
ENGINEERS &
CONSULTANTS**

MAIN OFFICE
1717 East Erwin
Tyler, Texas 75702
(903) 595-4421

MATERIAL DESCRIPTION

FAT CLAY WITH SAND(CH) medium stiff; red, orange, and gray
-soft
SANDY LEAN CLAY(CL) medium stiff; red and orange
FAT CLAY WITH SAND(CH) very stiff; red and orange
ASH SEDIMENT medium dense; gray and black
-loose
-medium dense
-loose
-gray
-very loose
-loose

Bottom of Boring @ 45'

WATER LEVEL
USC
SAMPLES
DEPTH (ft)

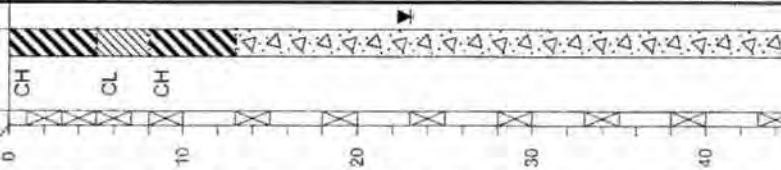

LOG OF BORING B-5										
PROJECT: Luminant Martin Lake PDP 1-3 Tatum, Texas					DATE: 2/22/08					
PROJECT NO.: G 2810-08					SURFACE ELEVATION: 415'					
BORING TYPE: Flight Auger										
FIELD STRENGTH DATA	BLOW COUNT	DRY DENSITY (pcf)	COMPRESSIVE STRENGTH (tsf)	FAILURE STRAIN (%)	CONFINING PRESSURE (psi)	Natural Moisture Content and Atterberg Limits			MINUS #200 SIEVE (%)	OTHER TESTS PERFORMED (Page Ref #)
						PPR (tsf)	Torvane (tsf)	Moisture Content (%)		
N=6	1.0	62	1.0			23	16	35	77	+40 Sieve =4%, +4 Sieve =1%
N=4	1.0	62	1.0			17	14	14	60	+40 Sieve =8%, +4 Sieve =1%
N=6	1.0	62	1.0			23	17	35	77	+40 Sieve =4%, +4 Sieve =1%
N=23	1.0	62	1.0			25	16	35	16	+40 Sieve =54%, +4 Sieve =24%
N=23	1.0	62	1.0			34	16	35	32	+40 Sieve =37%, +4 Sieve =18%
N=7	1.0	62	1.0			57	16	35	99	+40 Sieve =1%, +4 Sieve =0%
N=15	1.0	62	1.0							
N=8	1.0	62	1.0							
N=5	1.0	62	1.0							
N=4	1.0	62	1.0							
N=7	1.0	62	1.0							

Key to Abbreviations:
N - SPT Data (Blows/ft)
P - Pocket Penetrometer (tsf)
T - Torvane (tsf)
L - Lab Vane Shear (tsf)

Notes:
GPS Coordinates: N 32° 15.667', W 94° 34.936'

Est.: Measured: Perched:
Water level @ 23' and caved to 26' on

Water Level
Water Observations:
2/29/08



**ETTL
ENGINEERS &
CONSULTANTS**

MAIN OFFICE
1717 East Erwin
Tyler, Texas 75702
(903) 595-4421

MATERIAL DESCRIPTION

ASH SEDIMENT medium dense; black and tan
 SANDY LEAN CLAY (CL) stiff; red and tan
 -very stiff
 ASH SEDIMENT loose; black
 -medium dense
 Bottom of Boring @ 20'

WATER LEVEL
 USC
 SAMPLES
 DEPTH (ft)

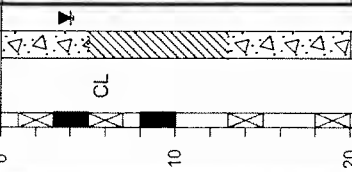

LOG OF BORING B-6

PROJECT: Luminant Martin Lake PDP 1-3
Tatum, Texas

PROJECT NO.: G 2810-08

BORING TYPE: Flight Auger

DATE

2/22/08

SURFACE ELEVATION
385'

FIELD STRENGTH DATA	BLOW COUNT ●	Qu (tsf) ▲	PPR (tsf) ■	Torvane (tsf) ◆	DRY DENSITY (pcf)	COMPRESSION STRENGTH (tsf)	FAILURE STRAIN (%)	CONFINING PRESSURE (psi)	Natural Moisture Content and Atterberg Limits			OTHER TESTS PERFORMED (Page Ref. #)		
									Plastic Limit	Moisture Content	Liquid Limit			
N=19 P=SF N=10 P=2.5	1.0	2.0	3.0	4.0					26	35	19	16	44	+40 Sieve =30%, +4 Sieve =13% +40 Sieve =7%, +4 Sieve =4%
N=9 N=12	1.0	2.0	3.0	4.0					40	68			61	+40 Sieve =5%, +4 Sieve =2%
													84	

Notes:
 GPS Coordinates: N 32° 15.591', W 94° 35.088', Minus #200 Sieve (84) @ 18'
 (Hydrometer - Specific Gravity 2.732).

Key to Abbreviations:
 N - SPT Data (Blows/Ft)
 P - Pocket Penetrometer (tsf)
 T - Torvane (tsf)
 L - Lab Vane Shear (tsf)

Water Level: Est. Measured: Perched:
 Seepage @ 4' while drilling. Water level @ 4' and caved to 7' upon completion. Water level @ 1' and caved to 8' on 2/29/08.



**ETTL
ENGINEERS &
CONSULTANTS**

MAIN OFFICE
1717 East Erwin
Tyler, Texas 75702
(903) 595-4421

MATERIAL DESCRIPTION

ASH SEDIMENT medium dense; black

-dense; black

-loose

-very loose

LEAN CLAY WITH SAND(CL) medium stiff;
orange and black

-tan and red

-medium dense; red and orange

SANDY FAT CLAY(CH) medium dense; red and
orange

Bottom of Boring @ 40'

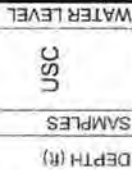

Water Level
Water Observations:
2/29/08

Est. Measured: Fringed:
Water level @ 3' and caved to 24' on

LOG OF BORING B-7

PROJECT: Luminant Martin Lake PDP 1-3
Tatum, Texas

PROJECT NO.: G 2810-08

BORING TYPE: Rotary Wash

DATE

2/28/08

SURFACE ELEVATION
390'

FIELD STRENGTH DATA	BLOW COUNT ●	Cu (tsf) ▲	PPR (tsf) ■	Torvane (tsf) ◆	DRY DENSITY (pcf)	COMPRESSIVE STRENGTH (tsf)	FAILURE STRAIN (%)	CONFINING PRESSURE (psi)	Atterberg Limits and Natural Moisture Content		MOISTURE CONTENT (%)	ATTERBERG LIMITS (%)			MINUS #200 SIEVE (%)	OTHER TESTS PERFORMED (Page Ref. #)
									Plastic Limit	Liquid Limit		LL	PL	PI		
N=13	20	1.0	1.0	1.0	98	2.30	2	6	20	35	37			16	+40 Sieve =49%, +4 Sieve =10%	
N=40	40	2.0	2.0	2.0					40	35	23					
P=4.5																
N=7	7	3.0	3.0	3.0					60	35	38			11		
N=4	4	3.0	3.0	3.0					60	35	27			75	+40 Sieve =4%, +4 Sieve =0%	
N=7	7	3.0	3.0	3.0					60	35	21					
N=22	22	3.0	3.0	3.0	104	0.50	13	22	60	35	27			69	+40 Sieve =27%, +4 Sieve =22%	
N=23	23	3.0	3.0	3.0					60	35						
N=22	22	3.0	3.0	3.0					60	35						

Key to Abbreviations:
N - SPT Data (Blows/FT)
P - Pocket Penetrometer (tsf)
T - Torvane (tsf)
L - Lab Vane Shear (tsf)

Notes:
GPS Coordinates: N 32° 15.646', W 94° 34.870'. Minus #200 Sieve (11%) @ 13'
(Hydrometer - Specific Gravity 2.655).



**ETTL
ENGINEERS &
CONSULTANTS**

MAIN OFFICE
1717 East Erwin
Tyler, Texas 75702
(903) 595-4421

MATERIAL DESCRIPTION

ASH SEDIMENT loose; gray
-very loose; gray and black
-medium dense; brown

-very loose; black

-strong odor

Bottom of Boring @ 30'

WATER LEVEL
USC
SAMPLES
DEPTH (ft)

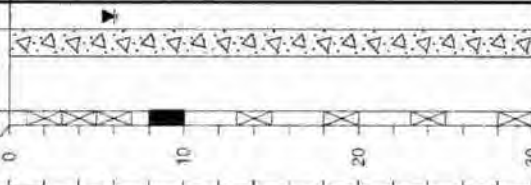

LOG OF BORING B-8

PROJECT: Luminant Martin Lake PDP 1-3
Tatum, Texas

PROJECT NO.: G 2810-08

BORING TYPE: Flight Auger

DATE: 2/20/08

SURFACE ELEVATION
390'

MOISTURE CONTENT (%)		73	72	85
ATTERBERG LIMITS (%)	LIQUID LIMIT			
	PLASTIC LIMIT			
	PLASTICITY INDEX			
MINUS #200 SIEVE (%)		95	95	99
OTHER TESTS		+40 Sieve =3%, +4 Sieve =0%	+40 Sieve =1%, +4 Sieve =0%	+40 Sieve =0%, +4 Sieve =0%

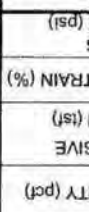
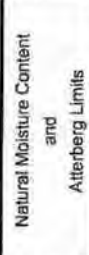

FIELD STRENGTH DATA	N=7	N=0	N=14	N=1	N=3	N=0	N=0
---------------------	-----	-----	------	-----	-----	-----	-----

DRY DENSITY (pcf)							
COMPRESSIVE STRENGTH (tsf)							
FAILURE STRAIN (%)							
CONFINING PRESSURE (psi)							

Key to Abbreviations:
N - SPT Data (Blows/FT)
P - Pocket Penetrometer (tsf)
T - Torvane (tsf)
L - Lab Vane Shear (tsf)

Notes:
GPS Coordinates: N 32°15.548', W 94°34.570'.

Est. Measured: Perched:
Seepage @ 4' while drilling. Water level @ 6' and caved to 17' upon completion. Dry and caved to 3' and on 2/29/08.



**ETTL
ENGINEERS &
CONSULTANTS**

MAIN OFFICE
1717 East Erwin
Tyler, Texas 75702
(903) 595-4421

MATERIAL DESCRIPTION

ASH SEDIMENT very loose; gray
-loose; black and gray
-medium dense
-very loose; black
-loose
-very loose
-gray and black; strong odor
Bottom of Boring @ 30'

WATER LEVEL
USC
SAMPLES
DEPTH (ft)

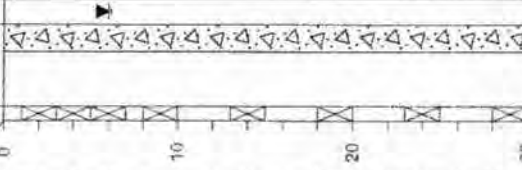

LOG OF BORING B-9										
PROJECT: Luminant Martin Lake PDP 1-3 Tatum, Texas					DATE: 2/20/08					
PROJECT NO.: G 2810-08					SURFACE ELEVATION: 390'					
BORING TYPE: Flight Auger										
FIELD STRENGTH DATA	BLOW COUNT	DRY DENSITY (pcf)	COMPRESSIVE STRENGTH (tsf)	FAILURE STRAIN (%)	CONFINING PRESSURE (psi)	Natural Moisture Content and Atterberg Limits			MINUS #200 SIEVE (%)	OTHER TESTS PERFORMED (Page Ref. #)
						Plastic Limit	Moisture Content	Liquid Limit		
▲ Qu (tsf)	● Blow Count	◆ Torvane (tsf)	■ PPR (tsf)	▲ Qu (tsf)	▲ Qu (tsf)	▲ Qu (tsf)	▲ Qu (tsf)	▲ Qu (tsf)	▲ Qu (tsf)	▲ Qu (tsf)
1 2 3 4	20 40 60 80	1.0 2.0 3.0 4.0	1.0 2.0 3.0 4.0	1 2 3 4	1 2 3 4	1 2 3 4	1 2 3 4	1 2 3 4	1 2 3 4	1 2 3 4
1 2 3 4	1 2 3 4	1 2 3 4	1 2 3 4	1 2 3 4	1 2 3 4	1 2 3 4	1 2 3 4	1 2 3 4	1 2 3 4	1 2 3 4
1 2 3 4	1 2 3 4	1 2 3 4	1 2 3 4	1 2 3 4	1 2 3 4	1 2 3 4	1 2 3 4	1 2 3 4	1 2 3 4	1 2 3 4
N=3	20	1.0	1.0	1	1	45	20	45	89	
N=10	30	1.5	1.5	2	2	45	20	45	77	+40 Sieve =4%, +4 Sieve =0%
N=18	40	2.0	2.0	3	3	57	20	57	94	+40 Sieve =3%, +4 Sieve =0%
N=0	50	2.5	2.5	4	4	49	20	49	68	+40 Sieve =4%, +4 Sieve =0%
N=10	60	3.0	3.0	1	1	88	20	88	97	+40 Sieve =2%, +4 Sieve =0%
N=5	70	3.5	3.5	2	2		20			
N=1	80	4.0	4.0	3	3		20			
N=0	90	4.0	4.0	4	4		20			

Key to Abbreviations:
N - SPT Data (Blows/Ft)
P - Pocket Penetrometer (tsf)
T - Torvane (tsf)
L - Lab Vane Shear (tsf)

Notes:
GPS Coordinates: N 32° 15.556', W 94° 34.913'. Minus #200 Sieve (89%) @ 1' (Hydrometer - Specific Gravity 2.761).

Water Observations:
6' and caved to 18' upon completion. Dry and caved to 4' on 2/29/08.

Est: [] Measured: [] Perched: []

Seepage @ 4' while drilling. Water level @

Water Level



CPT Data

Job Number 04.1908-0020 CPT Number B-02 Location Tatum-Tx
 Operator GLENN JOHNSON Date and T 16-Apr-2008 13:47:38 Cone Number F7.5CKEW2/B 1866
 Client _____ Elevation _____ Water Table _____

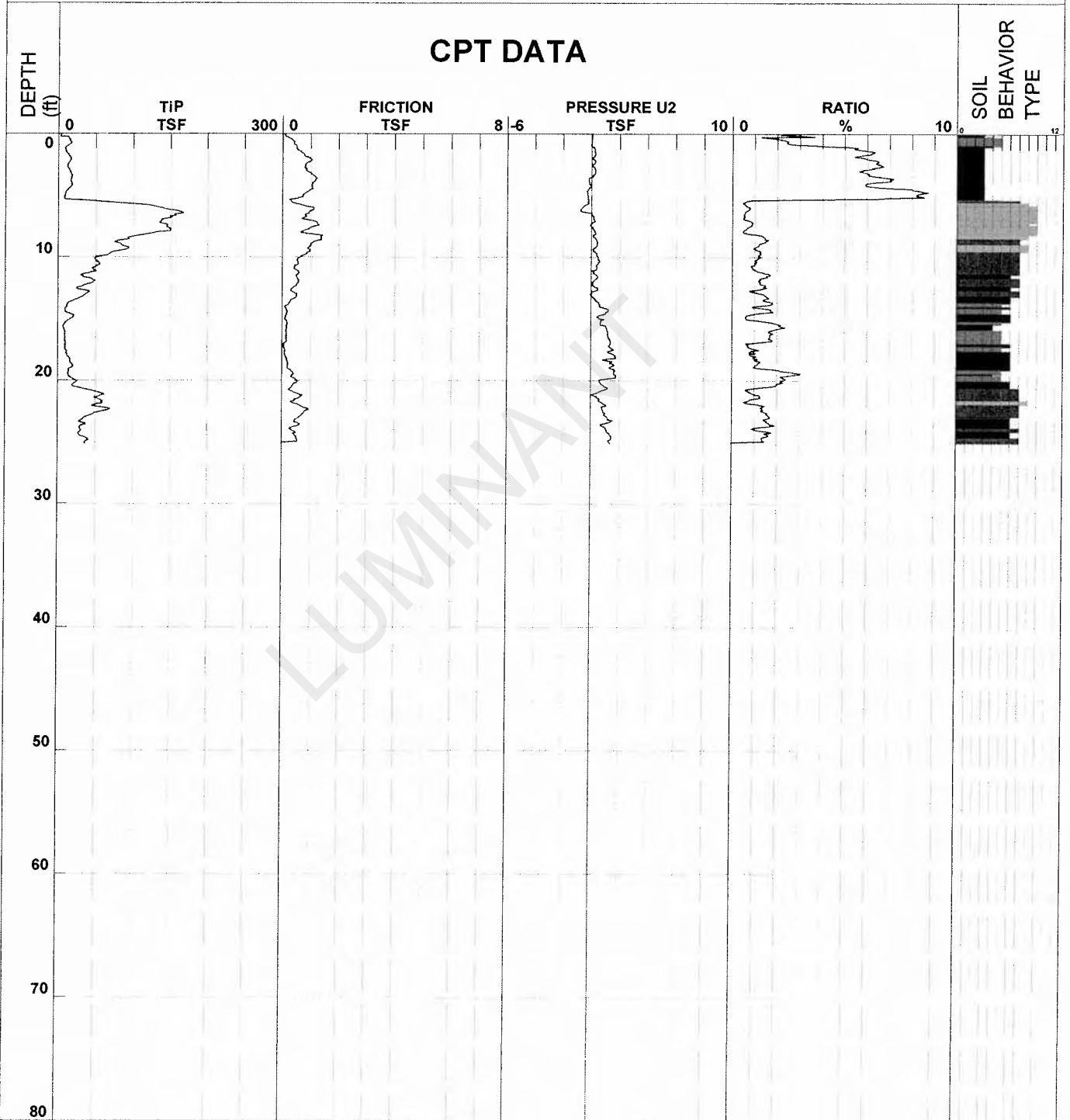

- | | | | |
|------------------------------|---------------------------------|--------------------------------|------------------------------------|
| ■ 1 - sensitive fine grained | ■ 4 - silty clay to clay | ■ 7 - silty sand to sandy silt | ■ 10 - gravelly sand to sand |
| ■ 2 - organic material | ■ 5 - clayey silt to silty clay | ■ 8 - sand to silty sand | ■ 11 - very stiff fine grained (*) |
| ■ 3 - clay | ■ 6 - sandy silt to clayey silt | ■ 9 - sand | ■ 12 - sand to clayey sand (*) |

Robertson et al. 1986 * Overconsolidated or Cemented



CPT Data

Job Number 04.1908-0020

CPT Number B-07

Location Tatum-Tx

Operator GLENN JOHNSON

Date and T 16-Apr-2008 12:40:51

Cone Number F7.5CKEW2/B 1866

Client _____

Elevation _____

Water Table _____

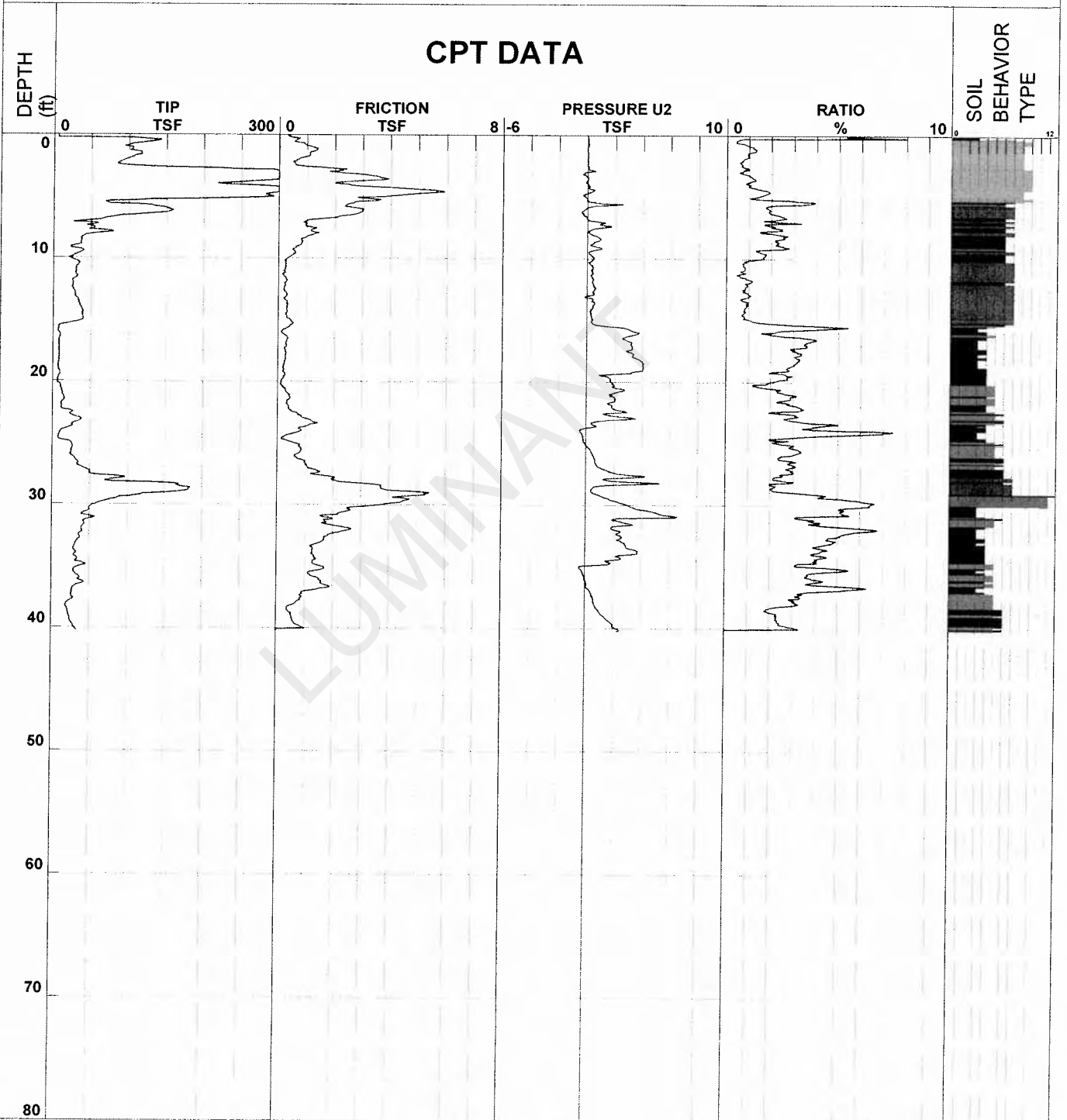

- | | | | |
|----------------------------|-------------------------------|------------------------------|----------------------------------|
| 1 - sensitive fine grained | 4 - silty clay to clay | 7 - silty sand to sandy silt | 10 - gravelly sand to sand |
| 2 - organic material | 5 - clayey silt to silty clay | 8 - sand to silty sand | 11 - very stiff fine grained (*) |
| 3 - clay | 6 - sandy silt to clayey silt | 9 - sand | 12 - sand to clayey sand (*) |

Robertson et al. 1986 * Overconsolidated or Cemented



CPT Data

Job Number 04.1908-0020

CPT Number B-12

Location Tatum-Tx

Operator GLENN JOHNSON

Date and T 16-Apr-2008 10:58:47

Cone Number F7.5CKEW2/B 1866

Client _____

Elevation _____

Water Table _____

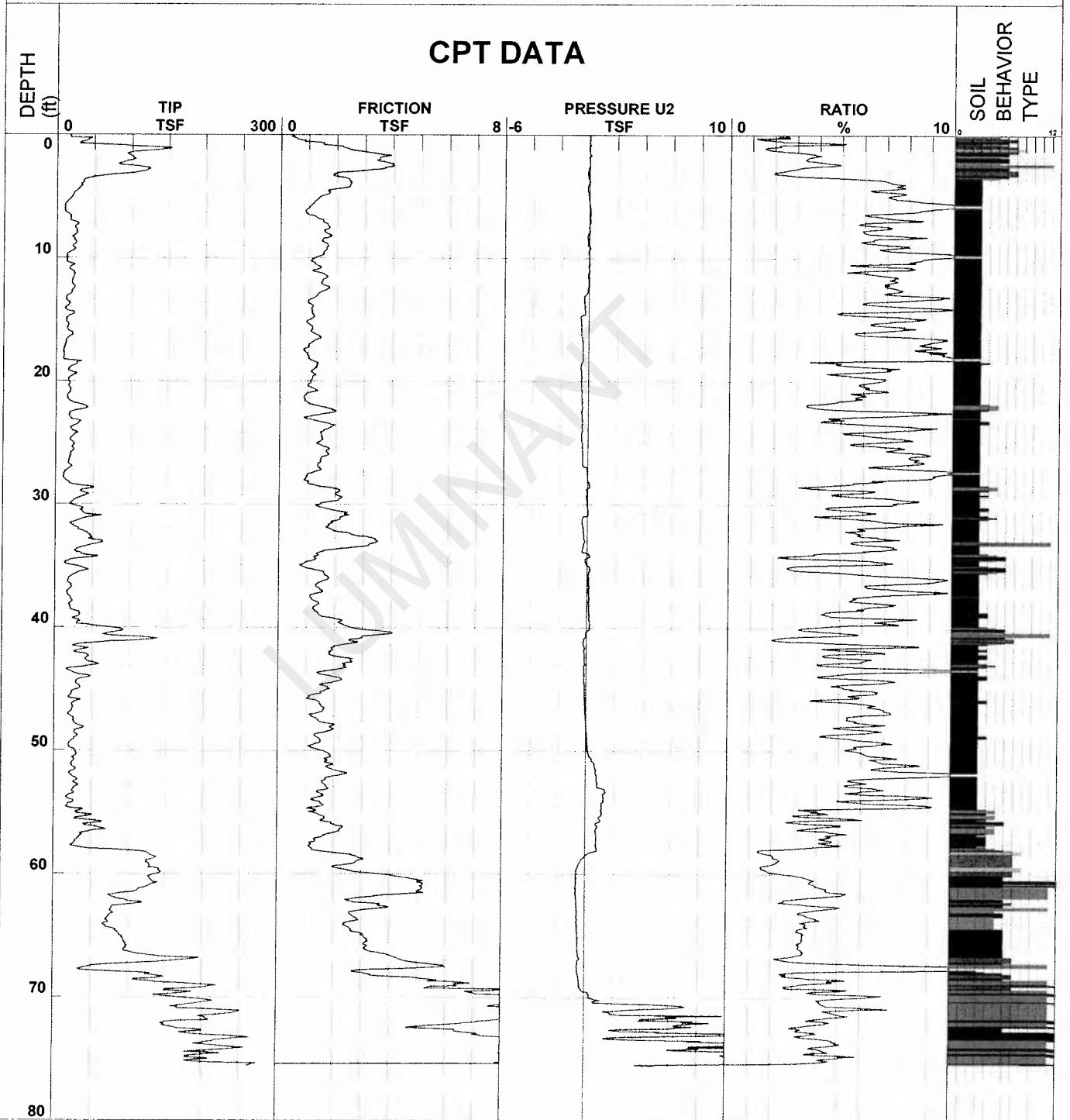

- | | | | |
|----------------------------|-------------------------------|------------------------------|----------------------------------|
| 1 - sensitive fine grained | 4 - silty clay to clay | 7 - silty sand to sandy silt | 10 - gravelly sand to sand |
| 2 - organic material | 5 - clayey silt to silty clay | 8 - sand to silty sand | 11 - very stiff fine grained (*) |
| 3 - clay | 6 - sandy silt to clayey silt | 9 - sand | 12 - sand to clayey sand (*) |

Robertson et al. 1986 * Overconsolidated or Cemented

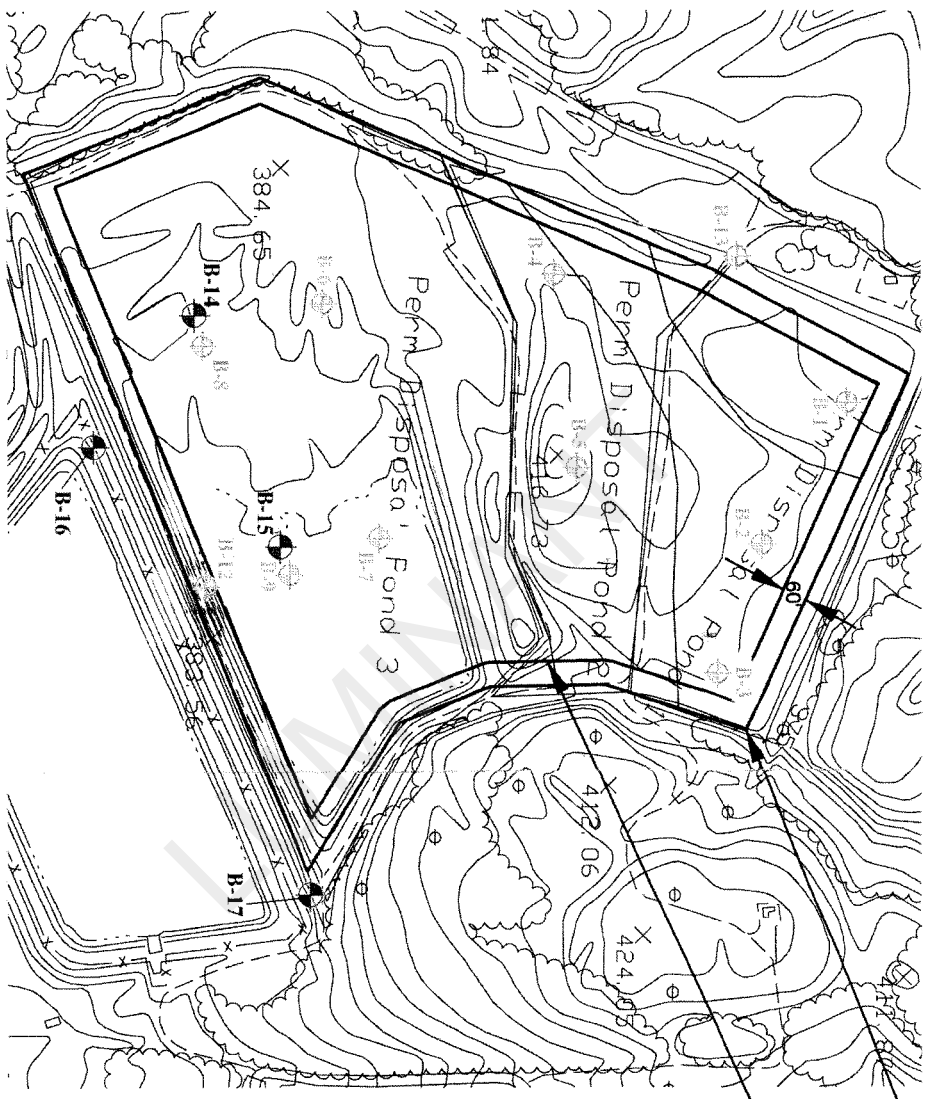

EXISTING POND LIMITS

PROPOSED CONTAINMENT BERM FOR HEIGHT EXPANSION

 EITL ENGINEERS & CONSULTANTS <small>1177 Lake Street Houston, Texas 77002 (281) 427-1277</small>	LUMINANT MARTIN LAKE PDP 1-3 TATUM, TEXAS	PLATE 1 - PLAN OF BORINGS	APPROVED BY: DRANN BY: K.C.R.
	DATE: MARCH 2008	SCALE: N.T.S.	JOB No.: G 3219-09



**ETTL
ENGINEERS &
CONSULTANTS**

MAIN OFFICE
1717 East Erwin
Tyler, Texas 75702
(903) 595-4421

MATERIAL DESCRIPTION

ASH SEDIMENT black;
--dark gray; with silty clay
--black; with sand
--gray
--black; with silt

Bottom of Boring @ 30'

USC
GEOLOGIC UNIT
WATER LEVEL

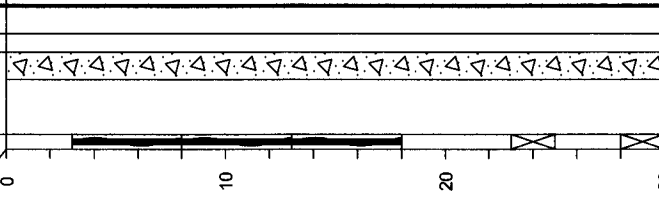

Water Level
Water Observations:

Est: Measured: Perched:
Seepage @ 5' while drilling.

Key to Abbreviations:
N - SPT Data (Blows/Ft)
P - Pocket Penetrometer (tsf)
T - Torvane (tsf)
L - Lab Vane Shear (tsf)

Notes:

GPS Coordinates: N 32° 15.549', W 94° 34.971'

LOG OF BORING B-14

PROJECT: Luminant Martin Lake PDP 1-3 Supplemental
Tatum, Texas

PROJECT NO.: G3219-09 BORING TYPE: Rotary Wash

DATE 8/18/09

SURFACE ELEVATION

MOISTURE CONTENT (%)	ATTERBERG LIMITS(%)			OTHER TESTS PERFORMED (Page Ref. #)
	LIQUID LIMIT	PLASTIC LIMIT	PLASTICITY INDEX	
59	111	47	64	+40 Sieve=3%, +4 Sieve=0%
86	65	51	14	+40 Sieve=1%, +4 Sieve=0%
83				
89				
95				

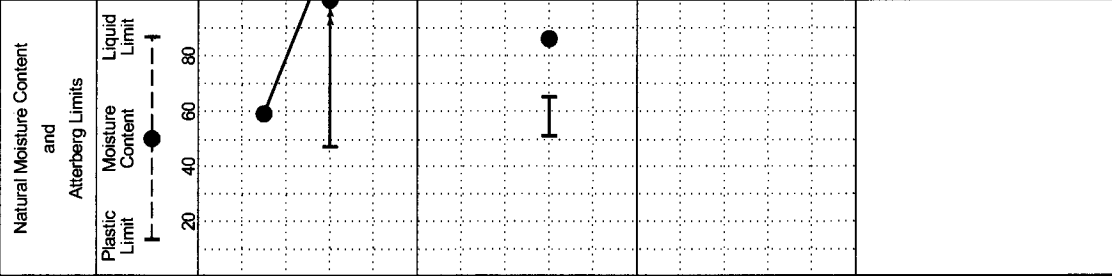

FIELD STRENGTH DATA	BLOW COUNT	DRY DENSITY (pcf)	COMPRESSIVE STRENGTH (tsf)	FAILURE STRAIN (%)	CONFINING PRESSURE (psi)
	● 20 40 60 80 ▲ Qu (tsf) 1 2 3 4 ■ PPR (tsf) 1.0 2.0 3.0 4.0 ◆ Torvane (tsf) 1.0 2.0 3.0 4.0				



**ETTL
ENGINEERS &
CONSULTANTS**

MAIN OFFICE
1717 East Erwin
Tyler, Texas 75702
(903) 595-4421

MATERIAL DESCRIPTION

LEAN CLAY (CL) tan, gray, and red
ASH SEDIMENT gray
--no recovery
--black; with clay and silt
ASH SEDIMENT gray; with sand; laminated
--with silt
--with sand
--full recovery
--no recovery
--black
--black and gray
Bottom of Boring @ 30'

USC
WATER LEVEL
GEOLOGIC UNIT

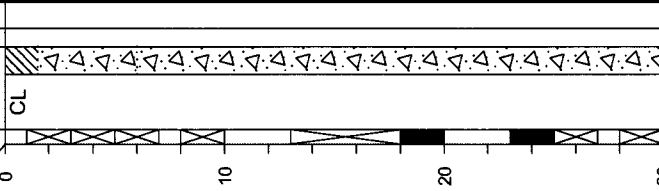

LOG OF BORING B-15
PROJECT: Luminant Martin Lake PDP 1-3 Supplemental
Tatum, Texas
PROJECT NO.: G3219-09
BORING TYPE: Rotary Wash

FIELD STRENGTH DATA	BLOW COUNT ● 20 40 60 80 ▲ Qu (tsf) 1 2 3 4 ■ PPR (tsf) 1.0 2.0 3.0 4.0 ◆ Torvane (tsf) 1.0 2.0 3.0 4.0	DRY DENSITY (pcf)	COMPRESSION STRENGTH (tsf)	FAILURE STRAIN (%)	CONFINING PRESSURE (psi)	Natural Moisture Content and Atterberg Limits			MOISTURE CONTENT (%)	PLASTICITY INDEX	MINUS #200 SIEVE (%)	OTHER TESTS PERFORMED (Page Ref. #)
						Plastic Limit	Moisture Content	Liquid Limit				
N=16	● 20 40 60 80 ▲ Qu (tsf) 1 2 3 4 ■ PPR (tsf) 1.0 2.0 3.0 4.0 ◆ Torvane (tsf) 1.0 2.0 3.0 4.0											
N=10												
N=22												
N=2												
N=1												
N=9												
N=1												

DATE: 8/18/09
SURFACE ELEVATION

ATTEBERG LIMITS (%)
LIQUID LIMIT (TL)
PLASTIC LIMIT (PL)
PLASTICITY INDEX (ID)

Notes:
GPS Coordinates: N 32° 15.556', W 94° 34.913'

Key to Abbreviations:
N - SPT Data (Blows/Ft)
P - Pocket Penetrometer (tsf)
T - Torvane (tsf)
L - Lab Vane Shear (tsf)

Water Level
Water Observations:
Est. Measured Perched:
Seepage @ 5' while drilling.



**ETTTL
ENGINEERS &
CONSULTANTS**

MAIN OFFICE
1717 East Erwin
Tyler, Texas 75702
(903) 595-4421

MATERIAL DESCRIPTION

SANDY LEAN CLAY (CL) orange and tan

--tan and gray

--orange and tan

CLAYEY SAND (SC) gray and orange

SANDY CLAYEY SILT (ML) orange and light gray

LEAN CLAY (CL) gray and reddish tan

--orange and tan; with trace of lignite

CLAYEY SAND (SC) tan and brown

SAND (SP) gray

Bottom of Boring @ 40'

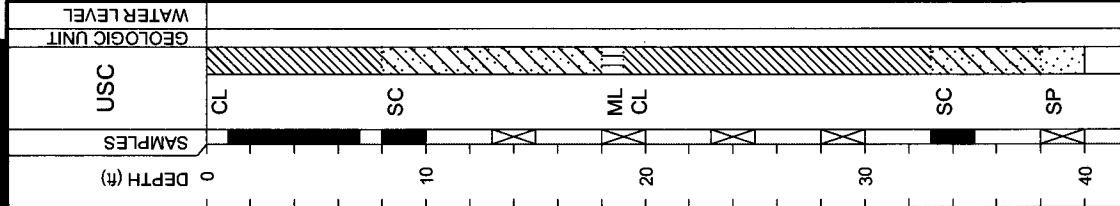

Water Level
Water Observations:

Est.: Measured: Perched:

Key to Abbreviations:
N - SPT Data (Blows/Ft)
P - Pocket Penetrometer (tsf)
T - Torvane (tsf)
L - Lab Vane Shear (tsf)

Notes:

GPS Coordinates: N 32° 15.484', W 94° 34.965'

LOG OF BORING B-16

PROJECT: Luminant Martin Lake PDP 1-3 Supplemental
Tatum, Texas

PROJECT NO.: G3219-09 BORING TYPE: Rotary Wash

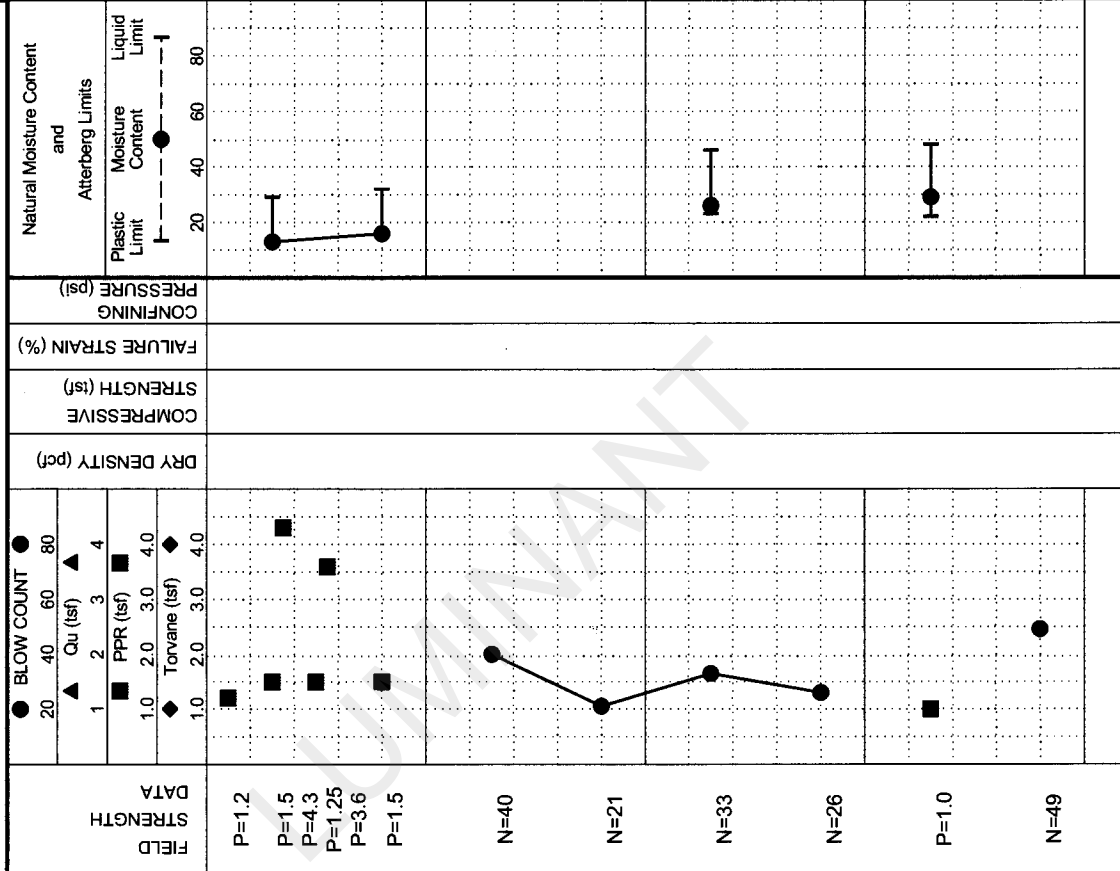

MOISTURE CONTENT (%)		ATTERBERG LIMITS (%)		MINUS #200 SIEVE (%)	OTHER TESTS PERFORMED (Page Ref. #)
LL	PL	PL	PI		
13	29	14	15	34	+40 Sieve=1%, +4 Sieve=0%
16	32	16	16	37	+40 Sieve=0%, +4 Sieve=0%
26	46	23	23	82	+40 Sieve=4%, +4 Sieve=1%
29	48	22	26	85	+40 Sieve=5%, +4 Sieve=0%

DATE: 8/18/09

SURFACE ELEVATION



**ETTL
ENGINEERS &
CONSULTANTS**

MAIN OFFICE
1717 East Erwin
Tyler, Texas 75702
(903) 595-4421

MATERIAL DESCRIPTION

SANDY LEAN CLAY(CL) orange and tan
--orange and brown
--red, tan, and yellow
--tan and gray
CLAYEY SAND(SC) tan
--tan and brown
--tan and gray, laminated
--gray and orange
--tan
--tan and orange
Bottom of Boring @ 40'

DEPTH (#)
0
10
20
30
40

SAMPLES

USC

GEOLOGIC UNIT

WATER LEVEL

Water Level
Water Observations:
Est.: Measured: Perched:
Bailed to 20' and open upon completion.

LOG OF BORING B-17

PROJECT: Luminant Martin Lake PDP 1-3 Supplemental
Tatum, Texas

PROJECT NO.: G3219-09 BORING TYPE: Rotary Wash

FIELD DATA
STRENGTH
P=4.5+
P=4.0
P=4.5
P=4.5+
N=40
N=22
N=19
N=20
N=30
N=24

BLOW COUNT
● 20 40 60 80
▲ Qu (tsf) 1 2 3 4
■ PPR (tsf) 1.0 2.0 3.0 4.0
◆ Torvane (tsf) 1.0 2.0 3.0 4.0

DRY DENSITY (pcf)
COMPRESSION STRENGTH (tsf)
FAILURE STRAIN (%)
CONFINING PRESSURE (psi)

Natural Moisture Content and Atterberg Limits
Plastic Limit
Moisture Content
Liquid Limit

MOISTURE CONTENT (%)
LIQUID LIMIT
PLASTIC LIMIT
PLASTICITY INDEX

MINUS #200 SIEVE (%)

OTHER TESTS PERFORMED (Page Ref. #)

DATE 8/18/09

SURFACE ELEVATION

Notes:
GPS Coordinates: N 32° 15.566', W 94° 34.736'

Key to Abbreviations:
N - SPT Data (Blows/Ft)
P - Pocket Penetrometer (tsf)
T - Torvane (tsf)
L - Lab Vane Shear (tsf)

APPENDIX B
LABORATORY TEST RESULTS

LUMINANT

BOTTOM ASH PONDS AND SCRUBBER POND

LUMIVANT



500 Century Plaza Drive, Suite 190
 Houston, Texas 77073
 Telephone: (281) 821-6868
 Fax: (281) 821-6870

SUMMARY OF LABORATORY RESULTS

CLIENT Luminant

PROJECT NAME Pond Slope Stability

PROJECT NUMBER 123-94128

PROJECT LOCATION Martin Lake

Borehole	Depth	Liquid Limit	Plastic Limit	Plasticity Index	Maximum Size (mm)	% <#200 Sieve	Classification	Water Content (%)	Dry Density (pcf)	Saturation (%)	Void Ratio
BH-201	0.0							19.2			
BH-201	2.0							13.7			
BH-201	6.0	26	14	12				9.4			
BH-201	8.0							15.1			
BH-201	13.0							16.3			
BH-201	18.0							20.8			
BH-201	23.0	36	14	22				19.9			
BH-201	28.0							18.2			
BH-201	33.0							15.0			
BH-201	38.0				0.85	40		14.9			
BH-201	43.0							21.4			
BH-201	48.0							23.5			
BH-202	0.0							20.8			
BH-202	2.0	55	19	36				17.1			
BH-202	4.0							20.5			
BH-202	6.0							26.7			
BH-202	8.0							15.3			
BH-202	13.0							14.9			
BH-202	18.0	29	13	16				17.1			
BH-202	23.0							17.6			
BH-202	28.0				0.85	49		18.1			
BH-202	33.0							17.0			
BH-202	38.0							20.8			
BH-202	43.0							23.0			
BH-202	48.0							26.2			
BH-203	0.0							12.6			
BH-203	2.0							14.6			
BH-203	4.0							16.1			
BH-203	6.0	50	19	31				21.5			
BH-203	8.0							22.3			
BH-203	13.0							18.0			
BH-203	18.0							14.6			
BH-203	23.0							17.3			
BH-203	25.0							19.9			
BH-203	28.0				2	17		23.6			
BH-203	30.0							27.7			
BH-203	33.0							29.1			
BH-203	38.0							29.4			
BH-204	0.0							13.9			
BH-204	2.0							21.1			
BH-204	4.0							15.0			
BH-204	6.0							16.6			
BH-204	8.0							13.5			

LAB SUMMARY - GINT STD US LAB.GDT - 11/29/12 16:20 - P1 - 2012 PROJECT FOLDERS\123-94128 LUMINANT POND SLOPE STABILITY\MARTIN LAKE\94128\MARTINLAKE.GPJ



500 Century Plaza Drive, Suite 190
 Houston, Texas 77073
 Telephone: (281) 821-6868
 Fax: (281) 821-6870

SUMMARY OF LABORATORY RESULTS

CLIENT Luminant

PROJECT NAME Pond Slope Stability

PROJECT NUMBER 123-94128

PROJECT LOCATION Martin Lake

Borehole	Depth	Liquid Limit	Plastic Limit	Plasticity Index	Maximum Size (mm)	% <#200 Sieve	Classification	Water Content (%)	Dry Density (pcf)	Saturation (%)	Void Ratio
BH-204	28.0				4.75	58		19.1			
BH-204	33.0							13.8			
BH-204	38.0							21.0			
BH-204	43.0	51	20	31				26.6			
BH-204	48.0							23.8			
BH-205	0.0							17.5			
BH-205	2.0							15.6			
BH-205	4.0							15.5			
BH-205	6.0							20.7			
BH-205	8.0							17.4			
BH-205	13.0	47	15	32				23.0			
BH-205	18.0							22.9			
BH-205	23.0	28	17	11				16.3			
BH-205	28.0				4.75	69		16.4			
BH-205	33.0							14.7			
BH-205	38.0							25.4			
BH-205	43.0							26.7			
BH-205	48.0							25.0			
BH-205	53.0				9.5	11		25.9			
BH-206	0.0							17.1			
BH-206	2.0	44	15	29				15.6			
BH-206	4.0							14.0			
BH-206	6.0							16.2			
BH-206	8.0							21.7			
BH-206	13.0							18.1			
BH-206	18.0							12.2			
BH-206	23.0							15.9			
BH-206	28.0	59	17	42				20.3			
BH-206	33.0							19.8			
BH-206	38.0							18.2			
BH-206	43.0							22.1			
BH-206	48.0							23.3			
BH-206	53.0							23.0			
BH-206	58.0							22.1			
BH-207	0.0							15.6			
BH-207	2.0							15.3			
BH-207	4.0							14.9			
BH-207	6.0							18.2			
BH-207	13.0							18.9			
BH-207	18.0							13.0			
BH-207	23.0							16.9			
BH-207	28.0	31	16	15				16.7			
BH-207	33.0							17.4			

LAB SUMMARY - GINT STD US LAB.GDT - 11/29/12 16:20 - P1 - 2012 PROJECT FOLDERS\123-94128 LUMINANT POND SLOPE STABILITY\MARTIN LAKE\94128\MARTINLAKE.GPJ



500 Century Plaza Drive, Suite 190
Houston, Texas 77073
Telephone: (281) 821-6868
Fax: (281) 821-6870

SUMMARY OF LABORATORY RESULTS

CLIENT Luminant

PROJECT NAME Pond Slope Stability

PROJECT NUMBER 123-94128

PROJECT LOCATION Martin Lake

Borehole	Depth	Liquid Limit	Plastic Limit	Plasticity Index	Maximum Size (mm)	% <#200 Sieve	Classification	Water Content (%)	Dry Density (pcf)	Saturation (%)	Void Ratio
BH-207	38.0							19.0			
BH-207	43.0							21.8			
BH-207	48.0							22.2			
BH-207	53.0							25.2			
BH-207	58.0							29.8			
BH-208	0.0							20.2			
BH-208	2.0							16.2			
BH-208	4.0							12.9			
BH-208	6.0							11.5			
BH-208	8.0	28	15	13				15.2			
BH-208	13.0							15.9			
BH-208	18.0							20.2			
BH-208	23.0							18.0			
BH-208	28.0							21.3			
BH-208	33.0							18.1			
BH-208	38.0							19.1			
BH-208	43.0							23.7			
BH-208	48.0				4.75	11		24.5			
BH-208	53.0							27.1			
BH-208	58.0							26.1			
BH-209	0.0							9.0			
BH-209	2.0							11.8			
BH-209	4.0	62	21	41				11.8			
BH-209	6.0							12.1			
BH-209	8.0							19.2			
BH-209	13.0							12.3			
BH-209	18.0							21.0			
BH-209	28.0	41	15	26				23.3			
BH-209	33.0							20.0			
BH-209	35.0							21.2			
BH-209	38.0							17.9			
BH-209	43.0							24.0			
BH-209	48.0							21.2			
BH-210	0.0							8.2			
BH-210	2.0							10.7			
BH-210	4.0							13.4			
BH-210	6.0							14.4			
BH-210	8.0							15.7			
BH-210	13.0							21.3			
BH-210	18.0	36	14	22				22.9			
BH-210	23.0							25.0			
BH-210	28.0							18.5			
BH-210	33.0							19.3			

LAB SUMMARY - GINT STD US LAB.GDT - 11/29/12 16:20 - P1 - 2012 PROJECT FOLDERS\123-94128 LUMINANT POND SLOPE STABILITY\MARTIN LAKE\94128\MARTINLAKE.GPJ



500 Century Plaza Drive, Suite 190
Houston, Texas 77073
Telephone: (281) 821-6868
Fax: (281) 821-6870

SUMMARY OF LABORATORY RESULTS

CLIENT Luminant

PROJECT NAME Pond Slope Stability

PROJECT NUMBER 123-94128

PROJECT LOCATION Martin Lake

Borehole	Depth	Liquid Limit	Plastic Limit	Plasticity Index	Maximum Size (mm)	% <#200 Sieve	Classification	Water Content (%)	Dry Density (pcf)	Saturation (%)	Void Ratio
BH-210	38.0							17.2			
BH-210	43.0							25.6			
BH-210	48.0				9.5	33		33.4			
BH-210	53.0							29.3			
BH-210	58.0							29.3			
BH-210	63.0							26.6			
BH-210	68.0							31.1			
BH-211	0.0							8.7			
BH-211	2.0							13.3			
BH-211	4.0							15.0			
BH-211	6.0							14.5			
BH-211	8.0							13.2			
BH-211	13.0							17.6			
BH-211	18.0	50	17	33				15.0			
BH-211	23.0							11.6			
BH-211	28.0				9.5	52		11.6			
BH-211	33.0							22.5			
BH-211	38.0							21.1			
BH-211	43.0							24.3			
BH-211	48.0							24.3			
BH-211	53.0							24.9			
BH-211	58.0							22.9			
BH-211	63.0							29.5			
BH-211	68.0							26.6			

LAB SUMMARY - GINT STD US LAB.GDT - 11/29/12 16:20 - P1_2012 PROJECT FOLDERS\123-94-128 LUMINANT POND SLOPE STABILITY\MARTIN LAKE\94128\MARTINLAKE.GPJ



500 Century Plaza Drive, Suite 190
Houston, Texas 77073
Telephone: (281) 821-6868
Fax: (281) 821-6870

GRAIN SIZE DISTRIBUTION

CLIENT Luminant

PROJECT NAME Pond Slope Stability

PROJECT NUMBER 123-94128

PROJECT LOCATION Martin Lake

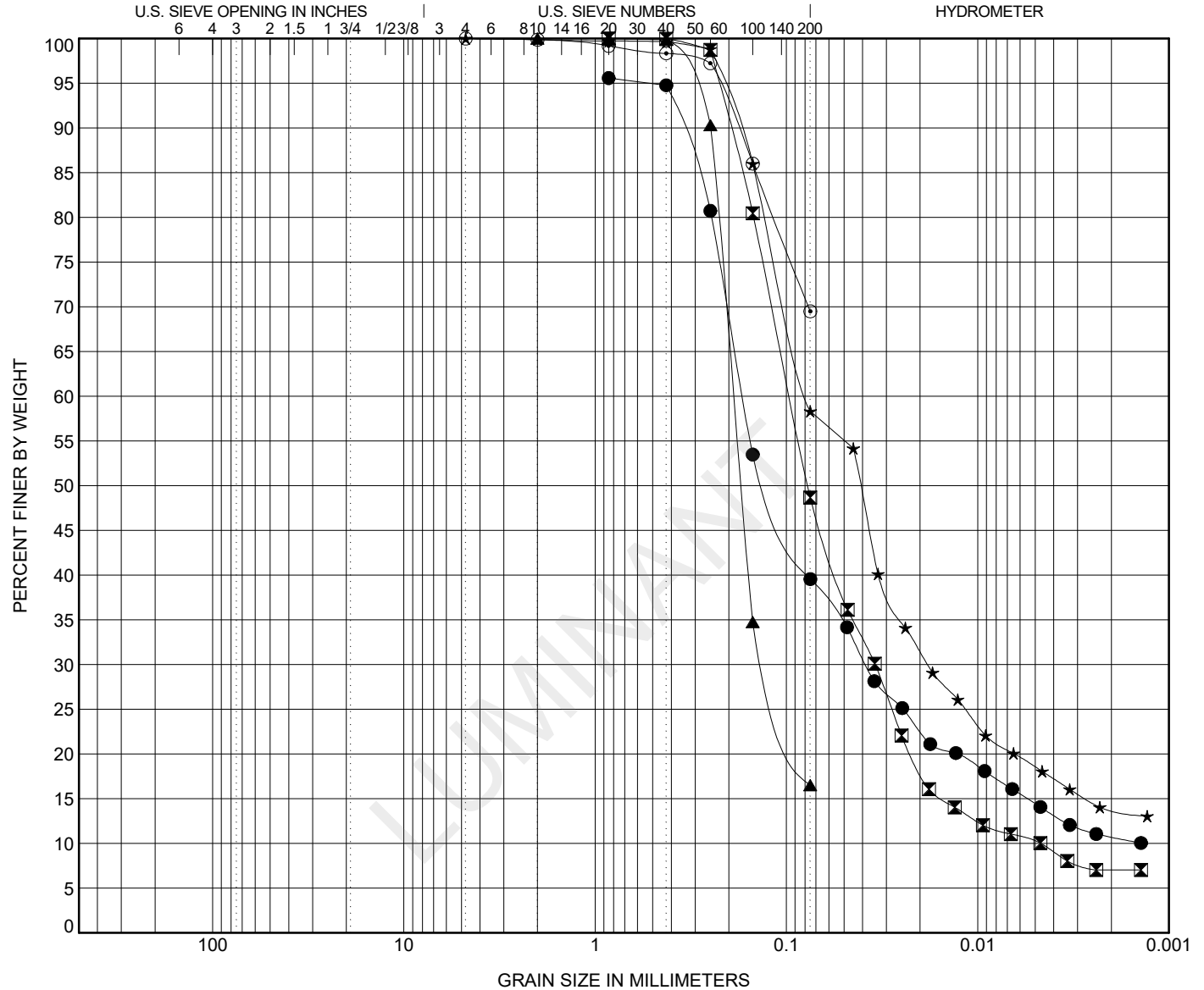

COBBLES	GRAVEL		SAND			SILT OR CLAY
	coarse	fine	coarse	medium	fine	

BOREHOLE	DEPTH	Classification					LL	PL	PI	Cc	Cu
● BH-201	38										
☒ BH-202	28								2.63	20.54	
▲ BH-203	28										
★ BH-204	28										
⊙ BH-205	28										
BOREHOLE	DEPTH	D100	D60	D30	D10	%Gravel	%Sand	%Silt	%Clay		
● BH-201	38	0.85	0.169	0.038			56.0	25.1	14.4		
☒ BH-202	28	0.85	0.096	0.034	0.005	0.0	51.3	38.4	10.2		
▲ BH-203	28	2	0.189	0.125		0.0	83.5	16.5			
★ BH-204	28	4.75	0.078	0.018		0.0	41.7	39.8	18.5		
⊙ BH-205	28	4.75				0.0	30.5	69.5			

GRAIN SIZE - COA - GINT STD US LAB.GDT - 11/29/12 - 16:21 - P:\2012 PROJECT FOLDERS\123-94128 LUMINANT POND SLOPE STABILITY\MARTIN LAKE\94128\MARTINLAKE.GPJ



500 Century Plaza Drive, Suite 190
Houston, Texas 77073
Telephone: (281) 821-6868
Fax: (281) 821-6870

GRAIN SIZE DISTRIBUTION

CLIENT Luminant

PROJECT NAME Pond Slope Stability

PROJECT NUMBER 123-94128

PROJECT LOCATION Martin Lake

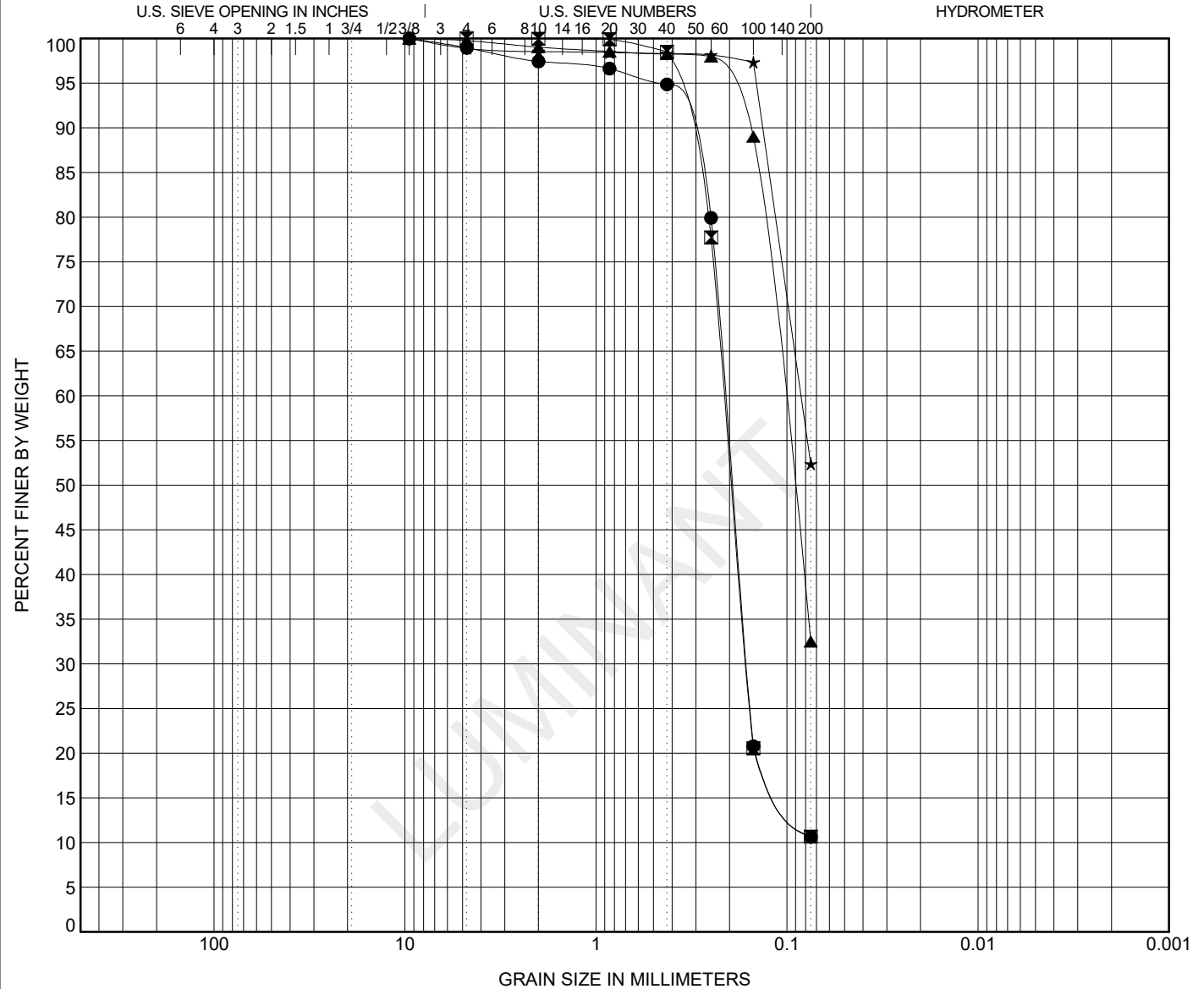

COBBLES	GRAVEL		SAND			SILT OR CLAY
	coarse	fine	coarse	medium	fine	

BOREHOLE	DEPTH	Classification					LL	PL	PI	Cc	Cu
● BH-205	53									1.74	2.93
☒ BH-208	48									1.75	2.98
▲ BH-210	48										
★ BH-211	28										

BOREHOLE	DEPTH	D100	D60	D30	D10	%Gravel	%Sand	%Silt	%Clay
● BH-205	53	9.5	0.21	0.162		1.1	88.3		10.6
☒ BH-208	48	4.75	0.213	0.163		0.0	89.3		10.7
▲ BH-210	48	9.5	0.105			0.2	67.2		32.5
★ BH-211	28	9.5	0.084			1.1	46.5		52.4

GRAIN SIZE - COA - GINT STD US LAB.GDT - 11/29/12 - 16:21 - P:\2012 PROJECT FOLDERS\123-94128 LUMINANT POND SLOPE STABILITY\MARTIN LAKE\94128\MARTINLAKE.GPJ

**UNCONSOLIDATED / UNDRAINED COMPRESSIVE STRENGTH
ASTM D 2850**

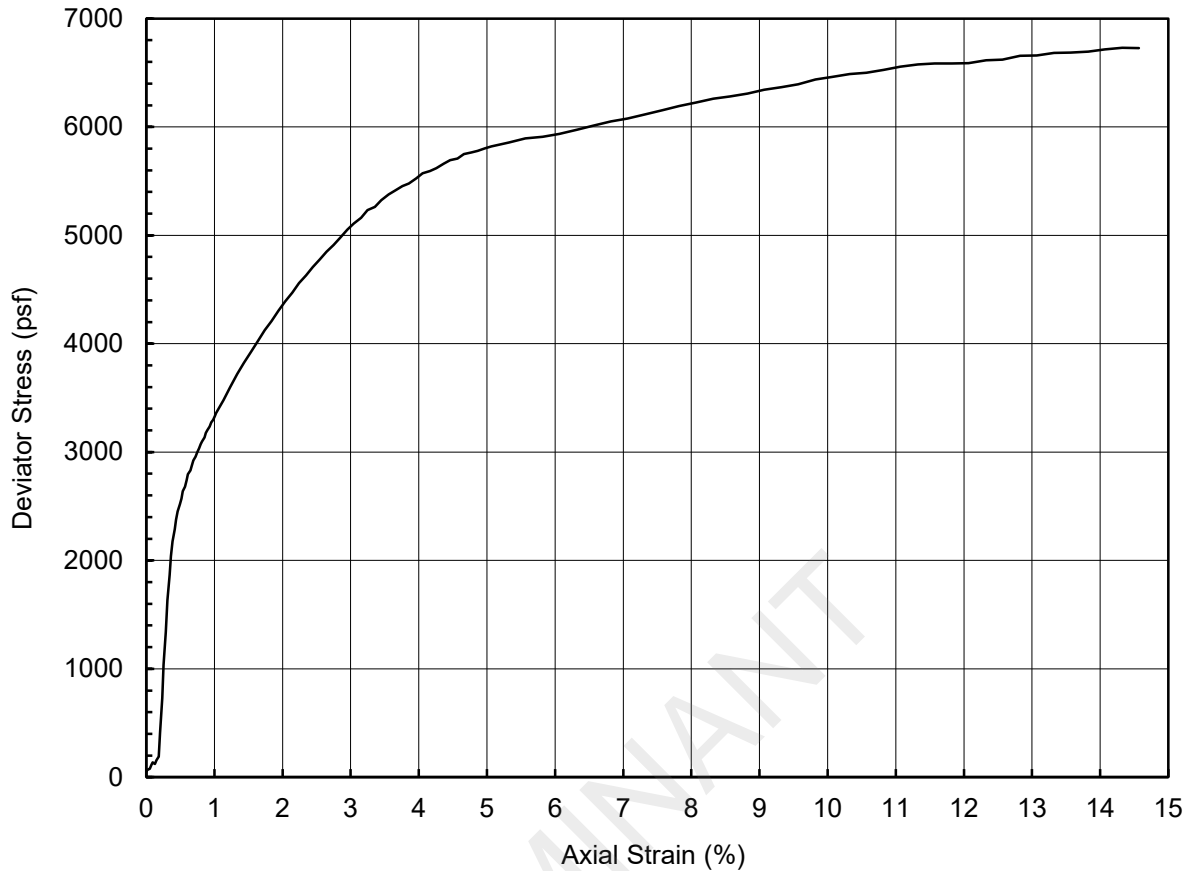

Specimen Description	Reddish Yellow Clay (visual classification)			
LL		PI	LI	USCS

Depth (ft)	4.0	Confining Pressure (psf)	617
Specimen Height (inch)	6.0	Strain Rate (%/min)	1.0
Specimen Diameter (inch)	2.8	Peak Deviator Stress (psf)	6732
Initial Specimen Weight (g)	1263.7	Axial Strain at Peak Stress (%)	14.3
Moist Unit Weight (pcf)	131.9		
Initial Water Content (%)	15		
Initial Dry Unit Weight (pcf)	114.6		

Project Title	Luminant - Martin Lake Slope Stability
Project Number	123-94128
Sample Type	Shelby Tube
Sample ID	BH-201 TO-3
Comments	

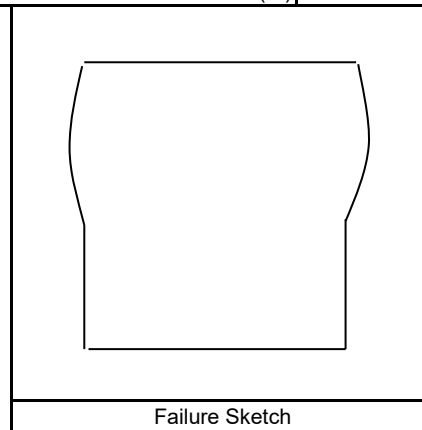

Performed by	PN
Date	12-Nov-12
Check	HR
Review	SBK

**UNCONSOLIDATED / UNDRAINED COMPRESSIVE STRENGTH
ASTM D 2850**

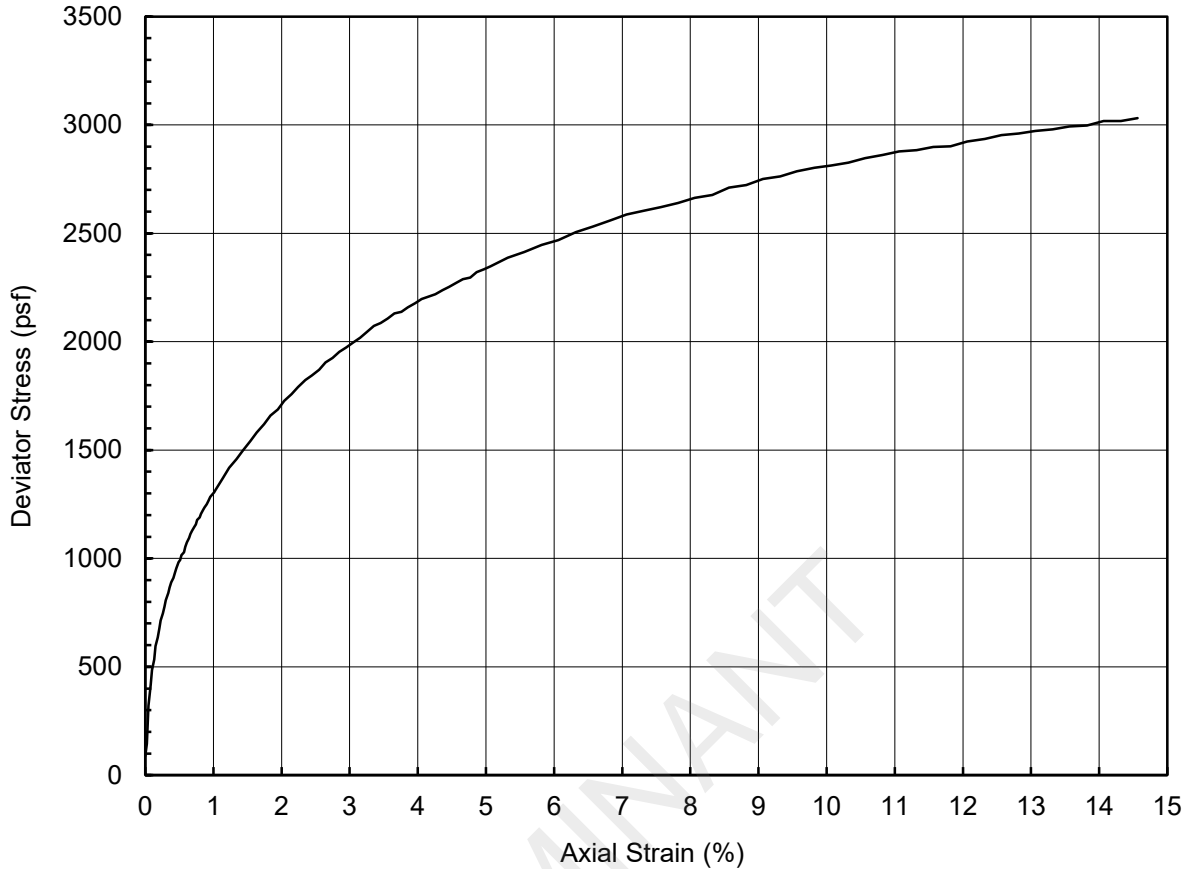

Specimen Description					Reddish Yellow Clay (visual classification)				
LL		PI		LI		USCS			

Depth (ft)	18.0	Confining Pressure (psf)	2371
Specimen Height (inch)	5.9	Strain Rate (%/min)	1.0
Specimen Diameter (inch)	2.8	Peak Deviator Stress (psf)	3035
Initial Specimen Weight (g)	1232.8	Axial Strain at Peak Stress (%)	14.8
Moist Unit Weight (pcf)	132.4		
Initial Water Content (%)	19		
Initial Dry Unit Weight (pcf)	111.7		

Project Title	Luminant - Martin Lake Slope Stability		
Project Number	123-94128		
Sample Type	Shelby Tube		
Sample ID	BH-202	TO-7	
Comments			

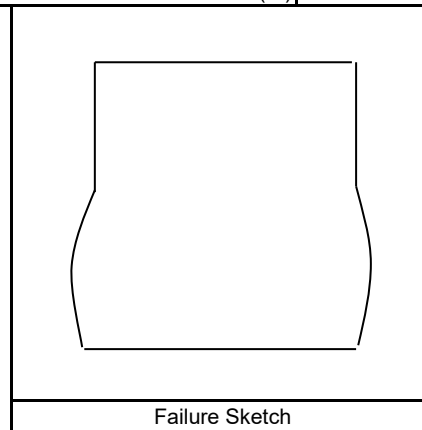

Performed by	PN
Date	13-Nov-12
Check	HR
Review	SBK

**UNCONSOLIDATED / UNDRAINED COMPRESSIVE STRENGTH
ASTM D 2850**

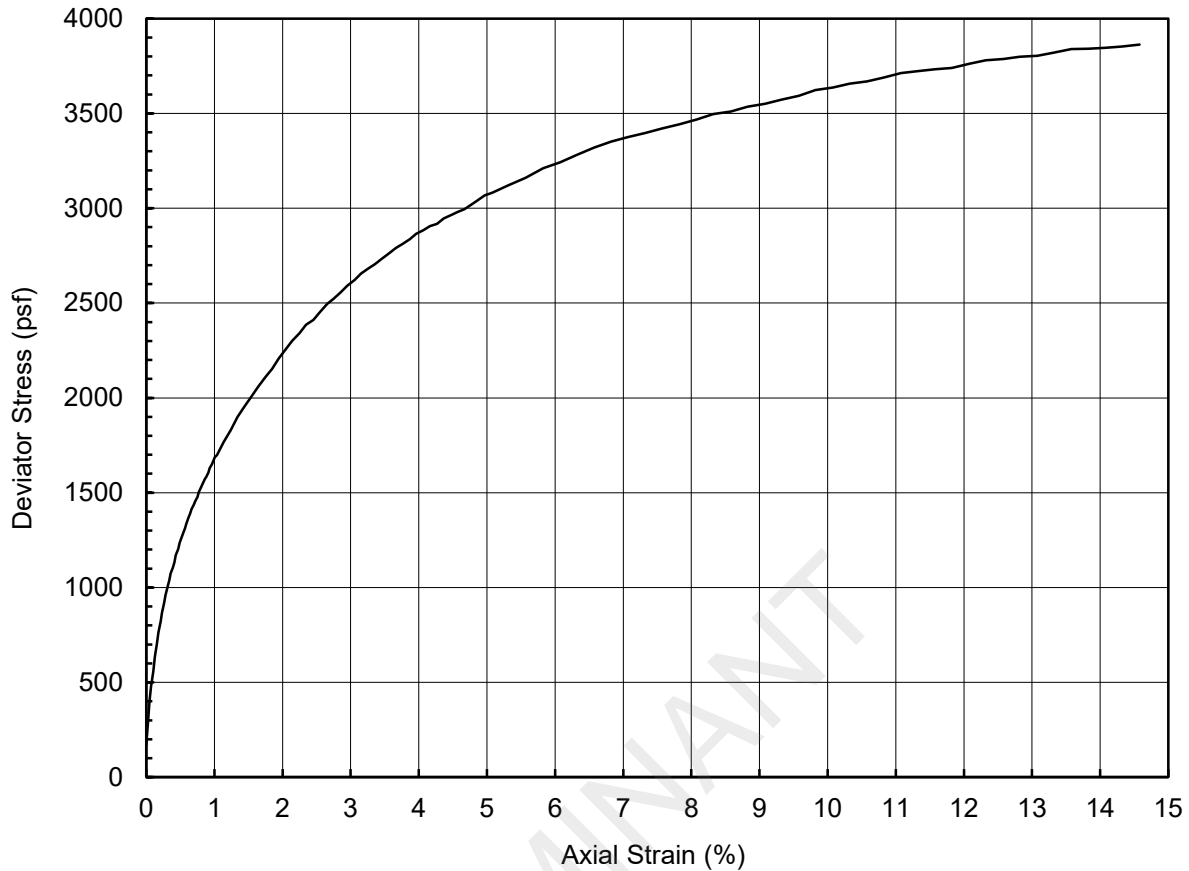

Specimen Description		Reddish Gray Clay (visual classification)		
LL		PI	LI	USCS

Depth (ft)	6.0	Confining Pressure (psf)	858
Specimen Height (inch)	6.0	Strain Rate (%/min)	1.0
Specimen Diameter (inch)	2.8	Peak Deviator Stress (psf)	3877
Initial Specimen Weight (g)	1199.6	Axial Strain at Peak Stress (%)	14.8
Moist Unit Weight (pcf)	124.7		
Initial Water Content (%)	21		
Initial Dry Unit Weight (pcf)	102.7		

Project Title	Luminant - Martin Lake Slope Stability
Project Number	123-94128
Sample Type	Shelby Tube
Sample ID	BH-203 TO-4
Comments	

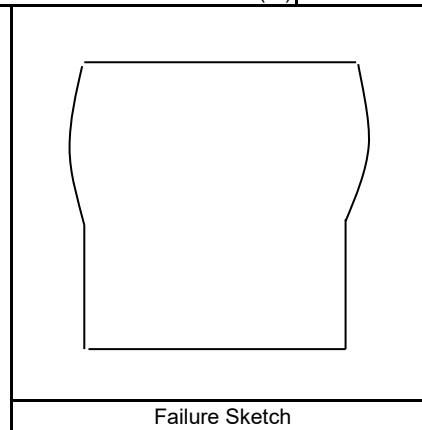

Performed by	PN
Date	13-Nov-12
Check	HR
Review	SBK

**UNCONSOLIDATED / UNDRAINED COMPRESSIVE STRENGTH
ASTM D 2850**

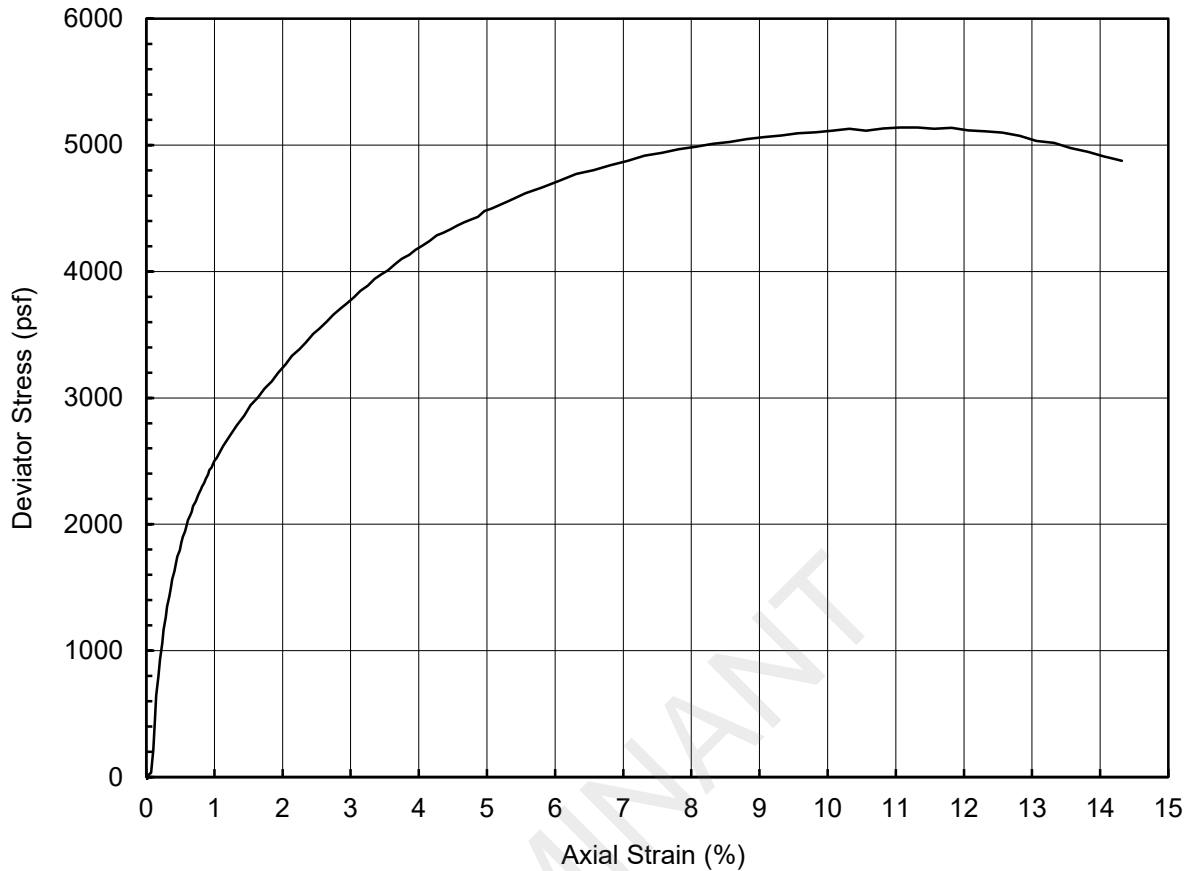

Specimen Description					Reddish Gray Clay (visual classification)				
LL		PI		LI		USCS			

Depth (ft)	23.0	Confining Pressure (psf)	3008
Specimen Height (inch)	6.0	Strain Rate (%/min)	1.0
Specimen Diameter (inch)	2.8	Peak Deviator Stress (psf)	5139
Initial Specimen Weight (g)	1192.8	Axial Strain at Peak Stress (%)	11.3
Moist Unit Weight (pcf)	126.6		
Initial Water Content (%)	26		
Initial Dry Unit Weight (pcf)	100.9		

Project Title	Luminant - Martin Lake Slope Stability		
Project Number	123-94128		
Sample Type	Shelby Tube		
Sample ID	BH-204	TO-8	
Comments			

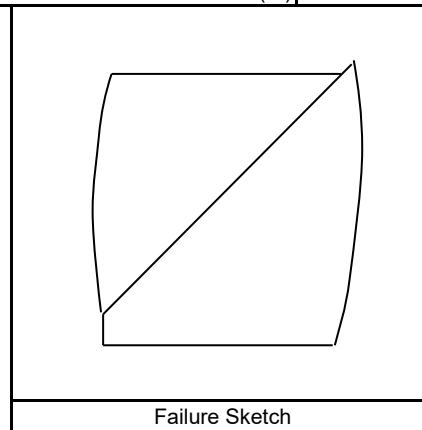

Performed by	PN
Date	13-Nov-12
Check	HR
Review	SBK

**UNCONSOLIDATED / UNDRAINED COMPRESSIVE STRENGTH
ASTM D 2850**

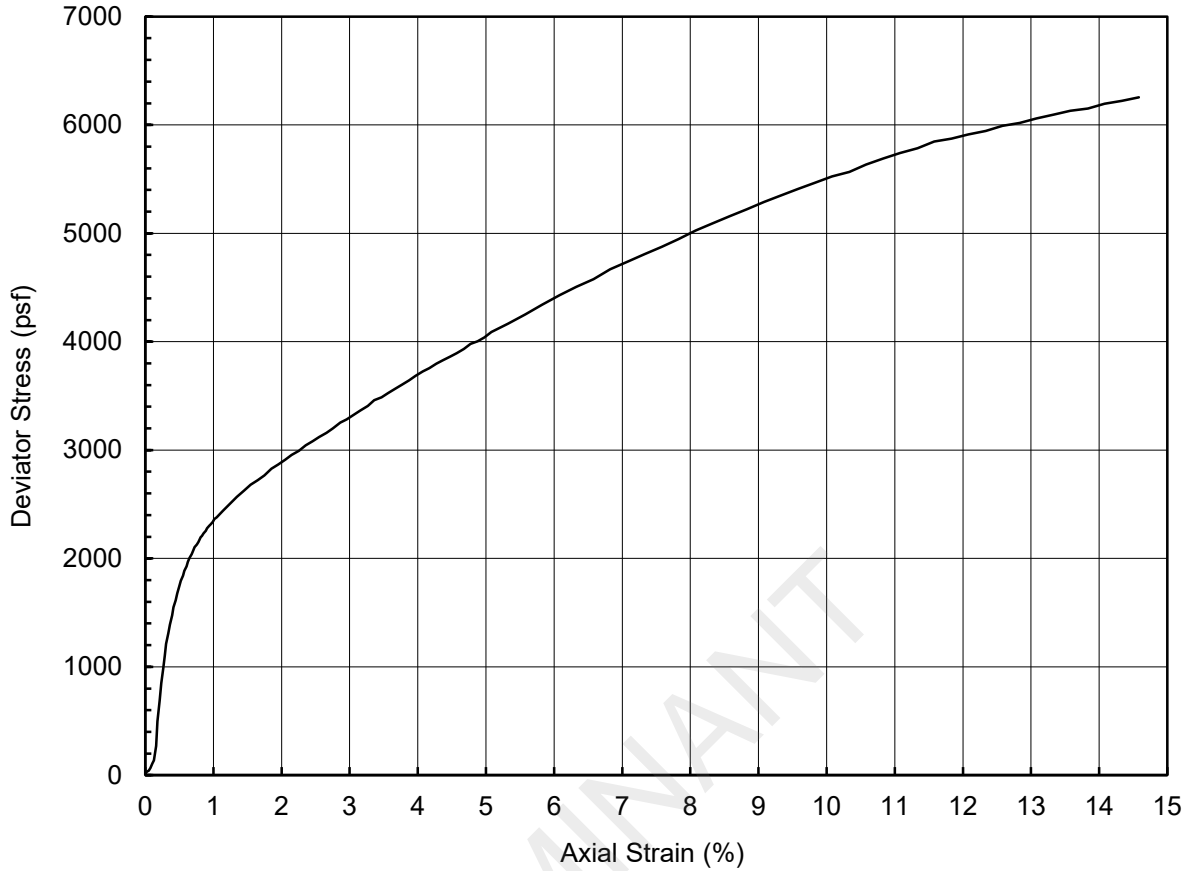

Specimen Description					Reddish Yellow Clay (visual classification)				
LL		PI		LI		USCS			

Depth (ft)	13.0	Confining Pressure (psf)	1760
Specimen Height (inch)	5.9	Strain Rate (%/min)	1.0
Specimen Diameter (inch)	2.8	Peak Deviator Stress (psf)	6270
Initial Specimen Weight (g)	1252.5	Axial Strain at Peak Stress (%)	14.8
Moist Unit Weight (pcf)	131.9		
Initial Water Content (%)	27		
Initial Dry Unit Weight (pcf)	104.1		

Project Title	Luminant - Martin Lake Slope Stability	
Project Number	123-94128	
Sample Type	Shelby Tube	
Sample ID	BH-205	TO-6
Comments		

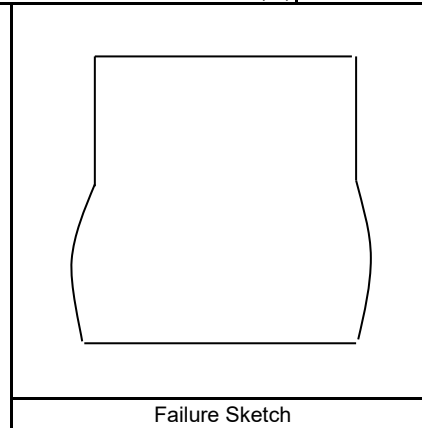

Performed by	PN
Date	13-Nov-12
Check	HR
Review	SBK

**UNCONSOLIDATED / UNDRAINED COMPRESSIVE STRENGTH
ASTM D 2850**

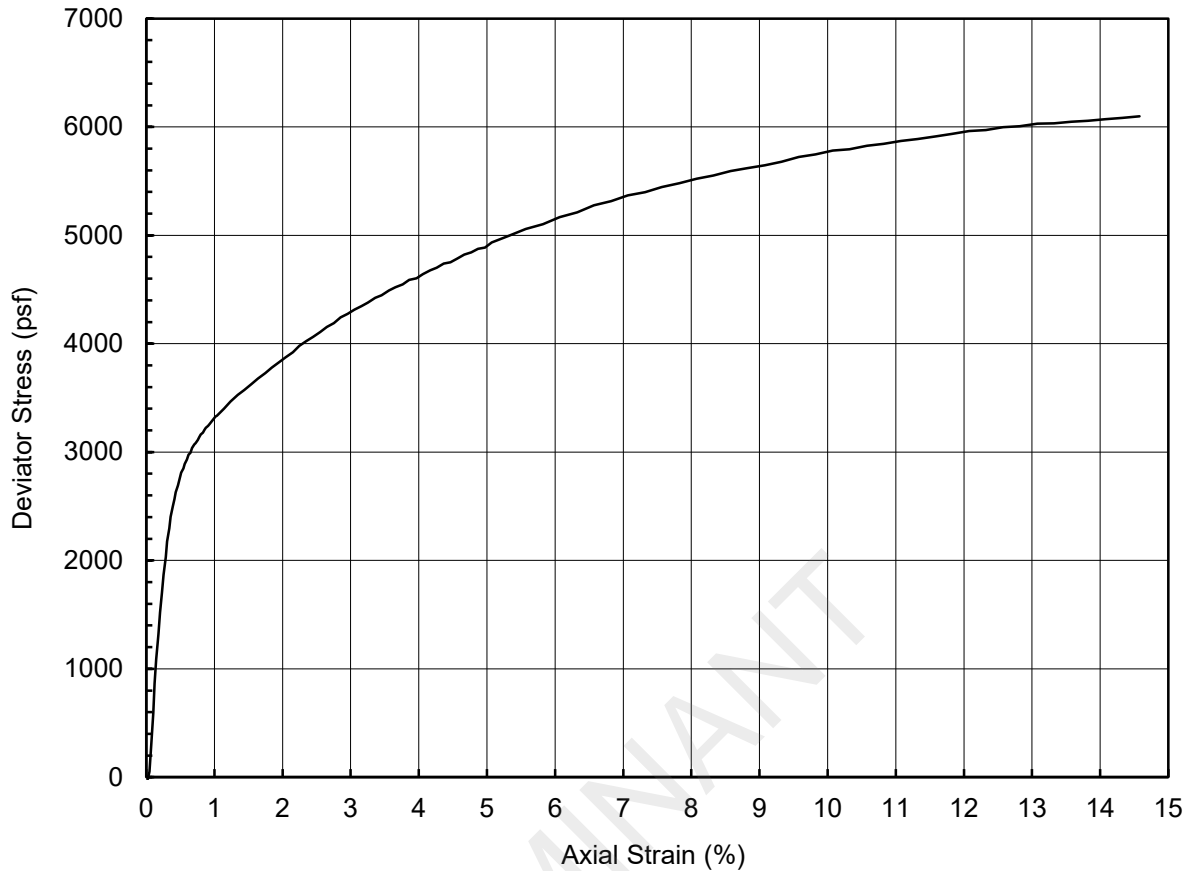

Specimen Description		Grayish Brown Fat Clay					
LL	59	PI	42	LI	0.1	USCS	CH

Depth (ft)	28.0	Confining Pressure (psf)	3627
Specimen Height (inch)	5.9	Strain Rate (%/min)	1.0
Specimen Diameter (inch)	2.8	Peak Deviator Stress (psf)	6110
Initial Specimen Weight (g)	1219.7	Axial Strain at Peak Stress (%)	14.8
Moist Unit Weight (pcf)	127.5		
Initial Water Content (%)	20		
Initial Dry Unit Weight (pcf)	106.6		

Project Title	Luminant - Martin Lake Slope Stability	
Project Number	123-94128	
Sample Type	Shelby Tube	
Sample ID	BH-206	TO-9
Comments		

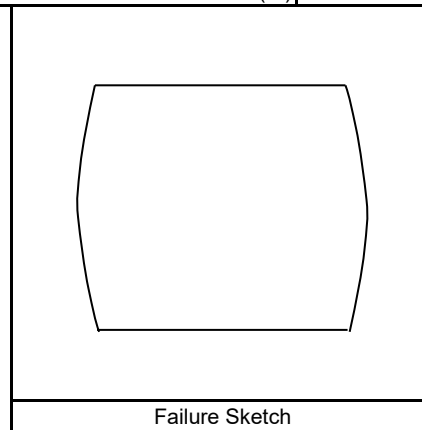

Performed by	PN
Date	15-Nov-12
Check	HR
Review	JF

**UNCONSOLIDATED / UNDRAINED COMPRESSIVE STRENGTH
ASTM D 2850**

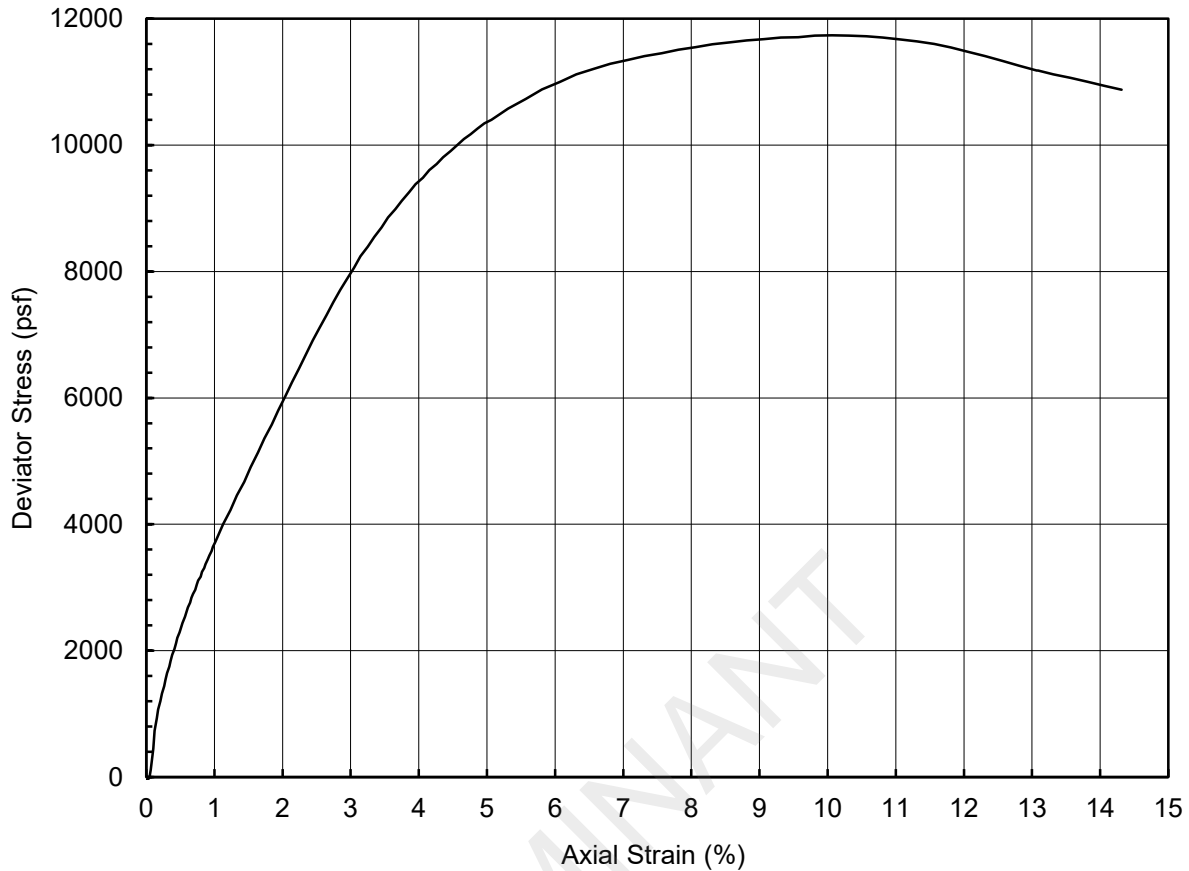

Specimen Description		Grayish Brown Lean Clay					
LL	31	PI	15	LI	0.0	USCS	CL

Depth (ft)	28.0	Confining Pressure (psf)	3620
Specimen Height (inch)	5.9	Strain Rate (%/min)	1.0
Specimen Diameter (inch)	2.8	Peak Deviator Stress (psf)	11735
Initial Specimen Weight (g)	1251.9	Axial Strain at Peak Stress (%)	10.1
Moist Unit Weight (pcf)	127.7		
Initial Water Content (%)	16		
Initial Dry Unit Weight (pcf)	109.9		

Project Title	Luminant - Martin Lake Slope Stability
Project Number	123-94128
Sample Type	Shelby Tube
Sample ID	BH-207 TO-9
Comments	

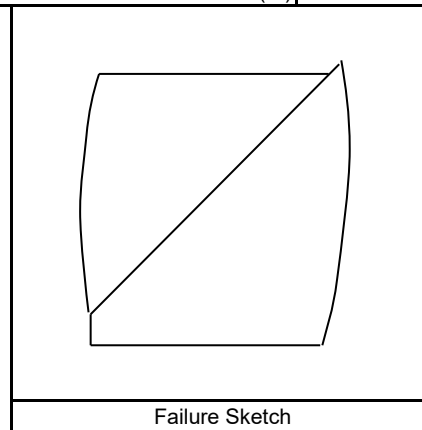

Performed by	PN
Date	15-Nov-12
Check	HR
Review	JF

**UNCONSOLIDATED / UNDRAINED COMPRESSIVE STRENGTH
ASTM D 2850**

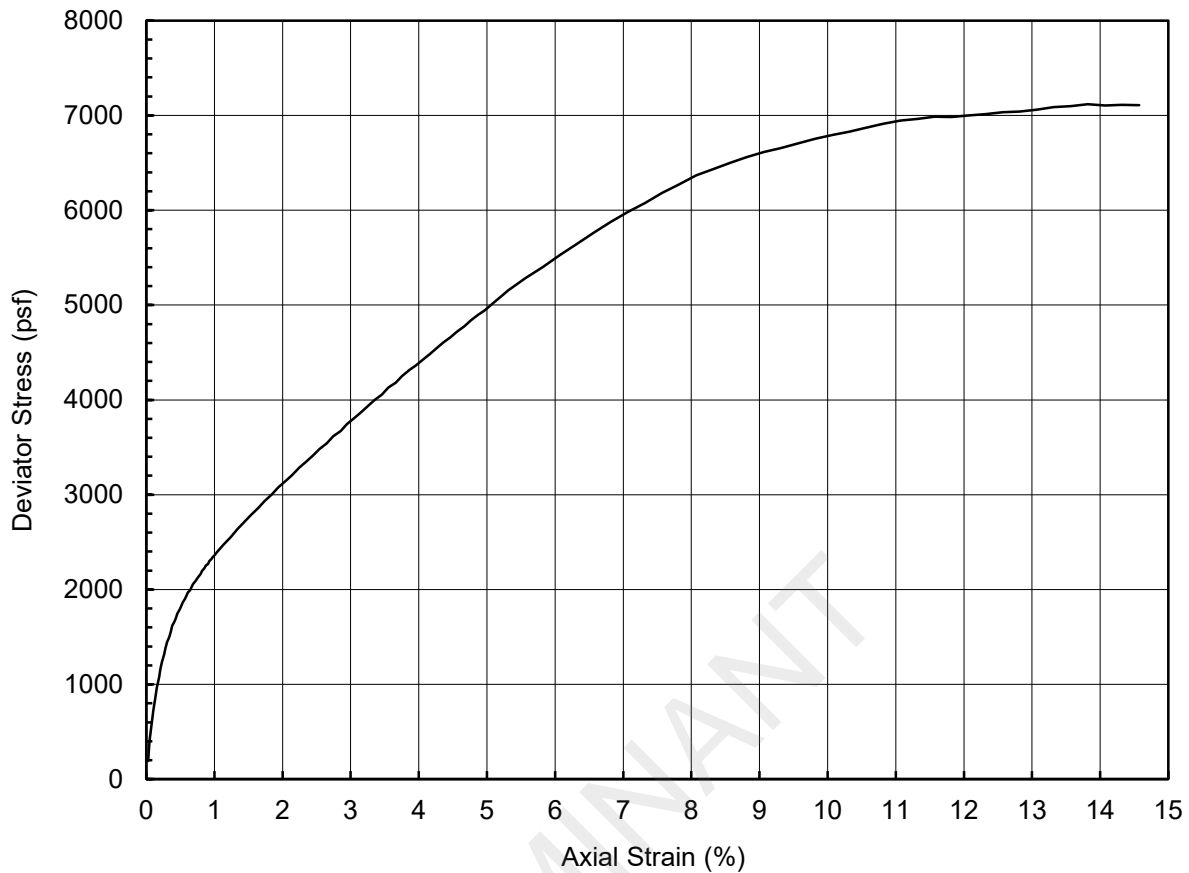

Specimen Description		Reddish Yellow Lean Clay					
LL	28	PI	13	LI	0.0	USCS	CL

Depth (ft)	8.0	Confining Pressure (psf)	1046
Specimen Height (inch)	5.9	Strain Rate (%/min)	1.0
Specimen Diameter (inch)	2.8	Peak Deviator Stress (psf)	7118
Initial Specimen Weight (g)	1287.7	Axial Strain at Peak Stress (%)	13.8
Moist Unit Weight (pcf)	138.1		
Initial Water Content (%)	14		
Initial Dry Unit Weight (pcf)	120.7		

Project Title	Luminant - Martin Lake Slope Stability	
Project Number	123-94128	
Sample Type	Shelby Tube	
Sample ID	BH-208	TO-5
Comments		

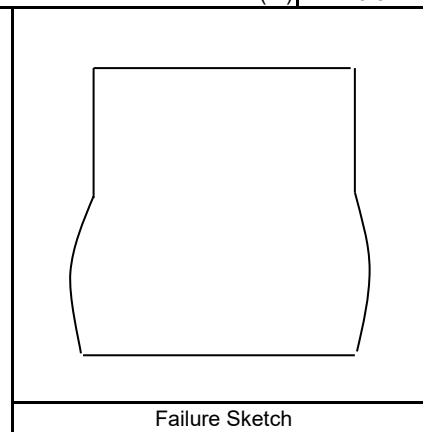

Performed by	PN
Date	16-Nov-12
Check	HR
Review	JF

**UNCONSOLIDATED / UNDRAINED COMPRESSIVE STRENGTH
ASTM D 2850**

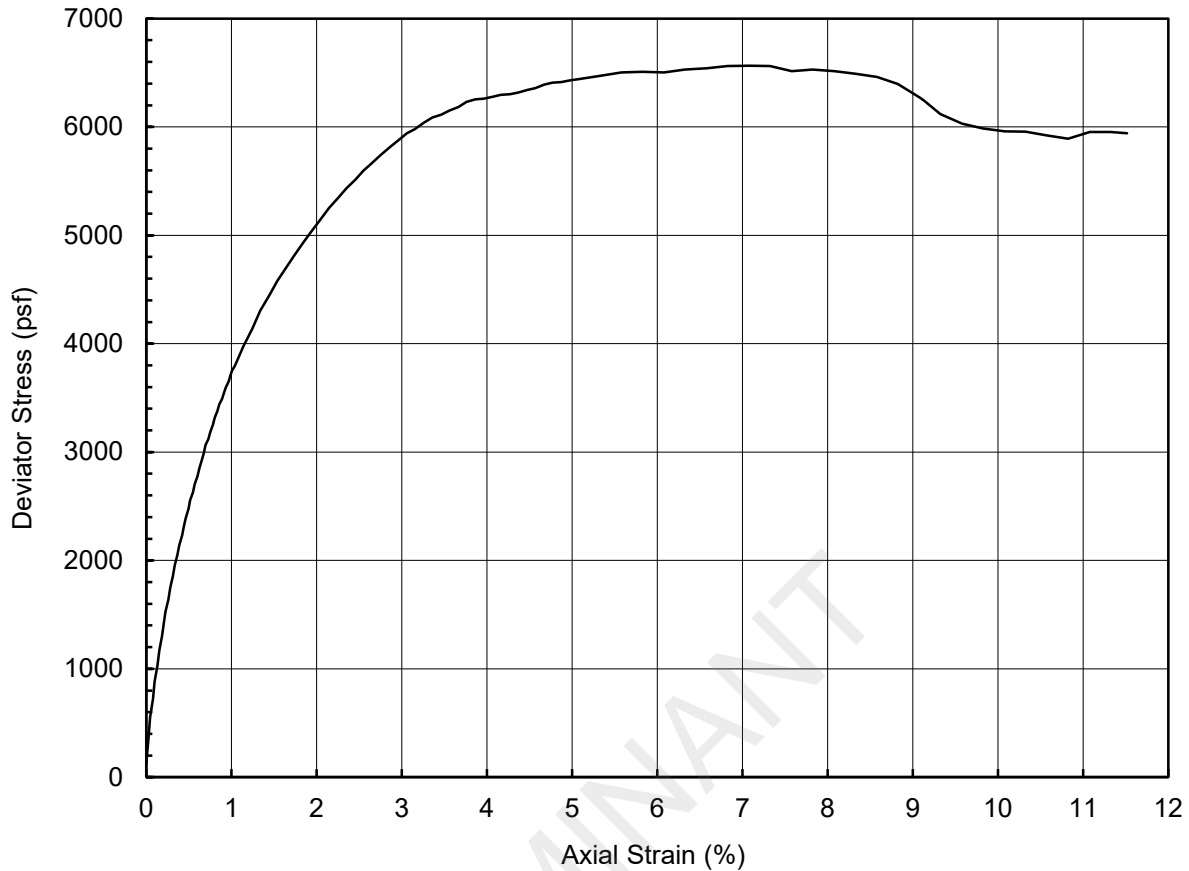

Specimen Description		Grayish Brown Lean Clay					
LL	41	PI	26	LI	0.3	USCS	CL

Depth (ft)	28.0	Confining Pressure (psf)	3624
Specimen Height (inch)	6.0	Strain Rate (%/min)	1.0
Specimen Diameter (inch)	2.8	Peak Deviator Stress (psf)	6566
Initial Specimen Weight (g)	1202.8	Axial Strain at Peak Stress (%)	7.1
Moist Unit Weight (pcf)	128.0		
Initial Water Content (%)	22		
Initial Dry Unit Weight (pcf)	104.7		

Project Title	Luminant - Martin Lake Slope Stability
Project Number	123-94128
Sample Type	Shelby Tube
Sample ID	BH-209 TO-9
Comments	

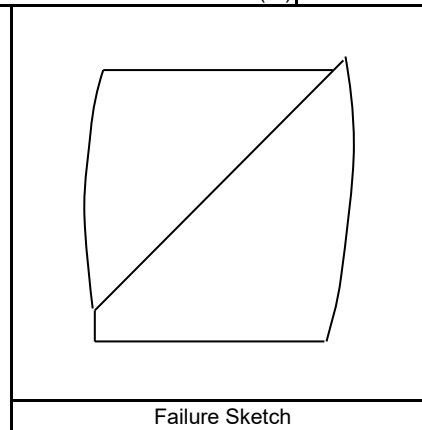

Performed by	PN
Date	16-Nov-12
Check	HR
Review	JF

**UNCONSOLIDATED / UNDRAINED COMPRESSIVE STRENGTH
ASTM D 2850**

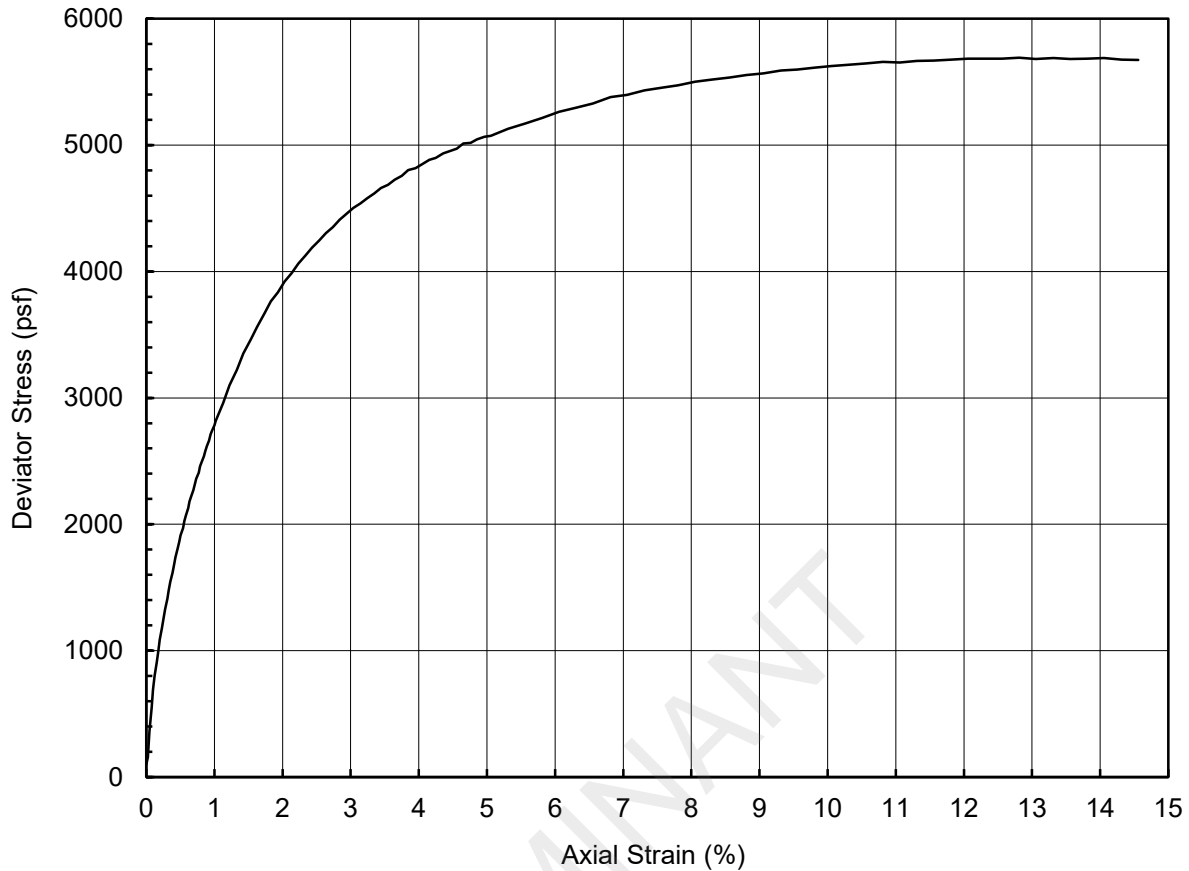

Specimen Description		Reddish Gray Lean Clay					
LL	36	PI	22	LI	0.5	USCS	CL

Depth (ft)	18.0	Confining Pressure (psf)	2375
Specimen Height (inch)	6.0	Strain Rate (%/min)	1.0
Specimen Diameter (inch)	2.8	Peak Deviator Stress (psf)	5691
Initial Specimen Weight (g)	1192.0	Axial Strain at Peak Stress (%)	12.8
Moist Unit Weight (pcf)	126.7		
Initial Water Content (%)	24		
Initial Dry Unit Weight (pcf)	102.2		

Project Title	Luminant - Martin Lake Slope Stability
Project Number	123-94128
Sample Type	Shelby Tube
Sample ID	BH-210 TO-7
Comments	

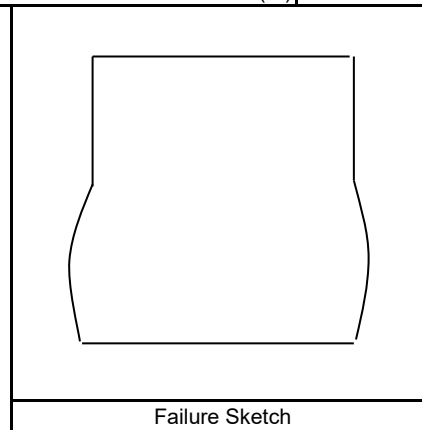

Performed by	PN
Date	16-Nov-12
Check	HR
Review	JF

PROJECT INFORMATION

PROJECT: Luminant East Ash Disposal
LOCATION: Rusk County, Texas
PROJECT NO: G 2872 - 09
CLIENT:
November 2008

TRIAxIAL TEST PROGRAM BY GARRY H. GREGORY, P.E.

ALL RIGHTS RESERVED - UNAUTHORIZED USE PROHIBITED
VERSION 1.0 - AUGUST 1998 - REVISED MARCH 24, 1999

THIS COPY LICENSED TO:
ETTL ENGINEERS AND CONSULTANTS, INC.
1717 East Erwin
Tyler, TX 75702

TEST DESCRIPTION

TYPE OF TEST & NO: CU with PF
SAMPLE TYPE: Possible Fill Sample
DESCRIPTION: Tan, Brown & Red Sandy Lean Clay
Sampled on Site: B-13 3' to 10' deep
ASSUMED SPECIFIC GRAVITY: 2.7 + 40 Sieve
LL: PL: PL: Percent -200:
REMARKS: Both Ends & Diameter Trimmed * #4 Sieve

PLATE: B.1

PLATE: B.2

PLATE: B.3

Number of Specimens = 3

SPECIMEN DATA
SPECIMEN NO. 1

	initial	final	Diameter		Height	
Moist soil & Tare :	522.40 g	621.90 g	top	2.04 in	Ht 1	4.44 in
Dry soil and Tare :	488.70 g	544.40 g	mid	2.04 in	Ht 2	4.44 in
Tare :	129.80 g	119.40 g	bot	2.04 in	Ht 3	4.44 in
Moisture content :			Avg	2.04 in	Ht4	4.44 in
Weight:	496.1 g				Avg Ht	
Change in Ht due to saturation :		-0.02 in	Initial specimen vol :			cc
Change in Ht due to consolidation :		-0.018 in	At test specimen vol :			cc
Change in pipet vol due to consolidation :		2.0 cc	Initial dry density :			pcf
Saturation Parameter " B " =	0.95		At test dry density:			pcf
Strain Rate (in/min) =	0.0005	Failure Strain % =	2.7	Effective Cell Pressure (psi) =		
σ_1' Failure (psi) =	20.41	σ_1 Failure (psi) =		Estimated $v =$	0.35	
σ_3' Failure (psi) =	5.41	σ_3 Failure (psi) =		Back Pressure (psi) =	50.0	
$\Delta U =$		Total Pore Pressure =	54.6	Cell Pressure (psi) =	60.0	

SPECIMEN NO. 2

	initial	final	Diameter		Height	
Moist soil & Tare :	549.60 g	636.40 g	top	2.01 in	Ht 1	4.44 in
Dry soil and Tare :	489.20 g	560.20 g	mid	2.01 in	Ht 2	4.44 in
Tare :	123.20 g	139.10 g	bot	2.01 in	Ht 3	4.44 in
Moisture content :			Avg	2.01 in	Ht4	4.44 in
Weight:	496.0 g				Avg Ht	
Change in Ht due to saturation :		-0.006 in	Initial specimen vol :			cc
Change in Ht due to consolidation :		-0.034 in	At test specimen vol :			cc
Change in pipet vol due to consolidation :		3.9 cc	Initial dry density :			pcf
Saturation Parameter " B " =	0.97		At test dry density:			pcf
Strain Rate (in/min) =	0.0005	Failure Strain % =	3.9	Effective Cell Pressure (psi) =		
σ_1' Failure (psi) =	37.62	σ_1 Failure (psi) =		Estimated $v =$	0.35	
σ_3' Failure (psi) =	12.02	σ_3 Failure (psi) =		Back Pressure (psi) =	50.0	
$\Delta U =$		Total Pore Pressure =	58.0	Cell Pressure (psi) =	70.0	

SPECIMEN NO. 3

	initial	final	Diameter		Height	
Moist soil & Tare :	594.50 g	656.50 g	top	2.06 in	Ht 1	4.54 in
Dry soil and Tare :	530.10 g	579.20 g	mid	2.06 in	Ht 2	4.54 in
Tare :	126.30 g	139.30 g	bot	2.06 in	Ht 3	4.54 in
Moisture content :			Avg	2.06 in	Ht4	4.54 in
Weight:	518.0 g				Avg Ht	
Change in Ht due to saturation :		-0.001 in	Initial specimen vol :			cc
Change in Ht due to consolidation :		-0.052 in	At test specimen vol :			cc
Change in pipet vol due to consolidation :		5.6 cc	Initial dry density :			pcf
Saturation Parameter " B " =	0.97		At test dry density:			pcf
Strain Rate (in/min) =	0.0005	Failure Strain % =	8.5	Effective Cell Pressure (psi) =		
σ_1' Failure (psi) =	100.17	σ_1 Failure (psi) =		Estimated $v =$	0.35	
σ_3' Failure (psi) =	54.77	σ_3 Failure (psi) =		Back Pressure (psi) =	50.0	
$\Delta U =$		Total Pore Pressure =	35.2	Cell Pressure (psi) =	90.0	

TRIAXIAL SHEAR TEST REPORT

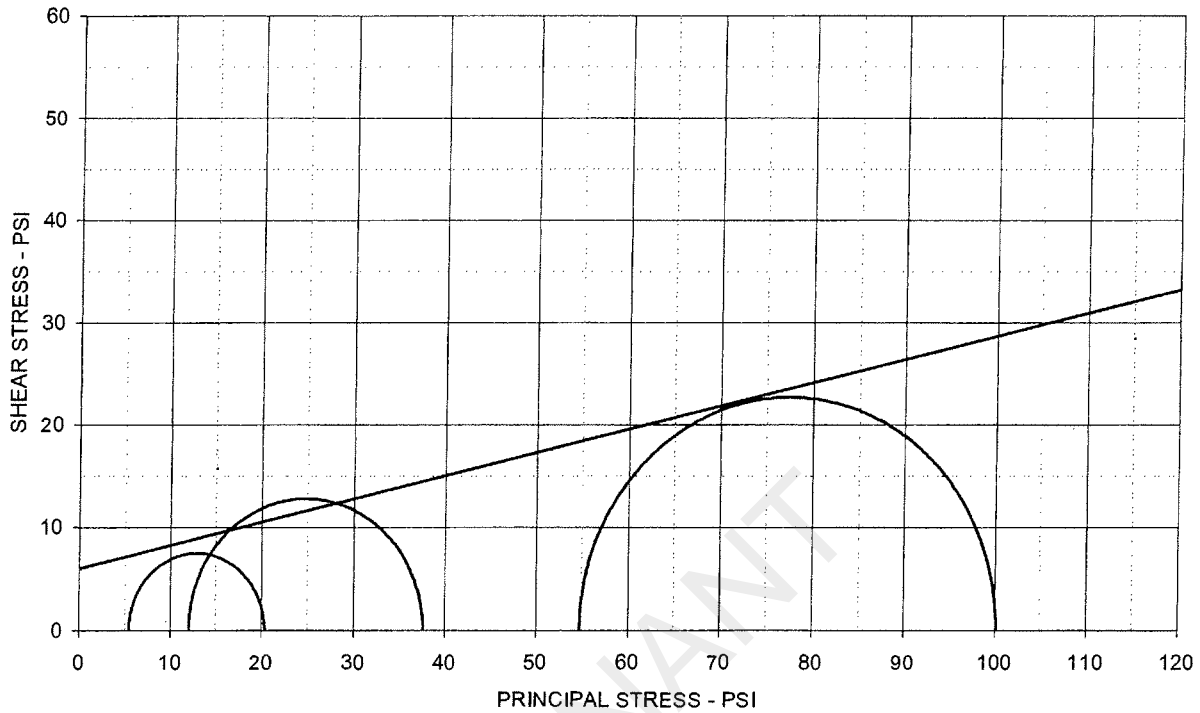

EFFECTIVE STRESS PARAMETERS

$\phi' = 12.8 \text{ deg}$

$c' = 6.0 \text{ psi}$

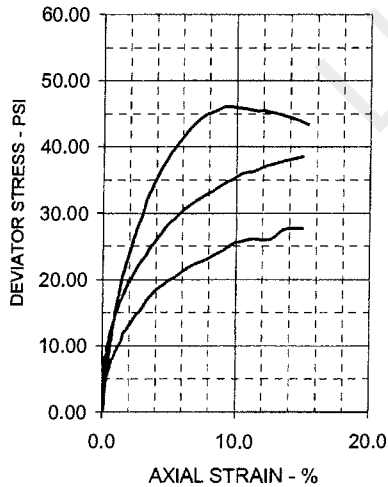

SPECIMEN NO.	1	2	3	4
INITIAL				
Moisture Content - %	15.8	16.6	15.9	
Dry Density - pcf	113.0	115.0	112.5	
Diameter - inches	2.04	2.01	2.06	
Height - Inches	4.44	4.44	4.54	
AT TEST				
Final Moisture - %	18.1	18.1	17.6	
Dry Density - pcf	114.0	116.9	115.1	
Calculated Diameter (in.)	2.02	2.00	2.04	
Height - Inches	4.40	4.40	4.49	
Effect. Cell Pressure - psi	10.0	20.0	40.0	
Failure Stress - psi	15.00	25.60	45.40	
Total Pore Pressure - psi	54.6	58.0	35.2	
Strain Rate - inches/min.	0.00050	0.00050	0.00050	
Failure Strain - %	2.7	3.9	8.5	
σ_1' Failure - psi	20.41	37.62	100.17	
σ_3' Failure - psi	5.41	12.02	54.77	

TEST DESCRIPTION

TYPE OF TEST & NO: CU with PP
 SAMPLE TYPE: Possible Fill Sample
 DESCRIPTION: Tan, Brown & Red Sandy Lean Clay
 Sampled on Site, B-13 3' to 10' deep
 ASSUMED SPECIFIC GRAVITY: 2.7 + 40 Sieve
 LL: PL: PI: Percent -200:
 REMARKS: Both Ends & Diameter Trimmed + # 4 Sieve
 G 2972-08, B-13, 3'-10' Fill

PROJECT INFORMATION

PROJECT: Luminant East Ash Disposal
 LOCATION: Rusk County, Texas
 PROJECT NO: G 2972 - 08
 CLIENT:
 November 2008

ETTL ENGINEERS & CONSULTANTS

PLATE: B.1

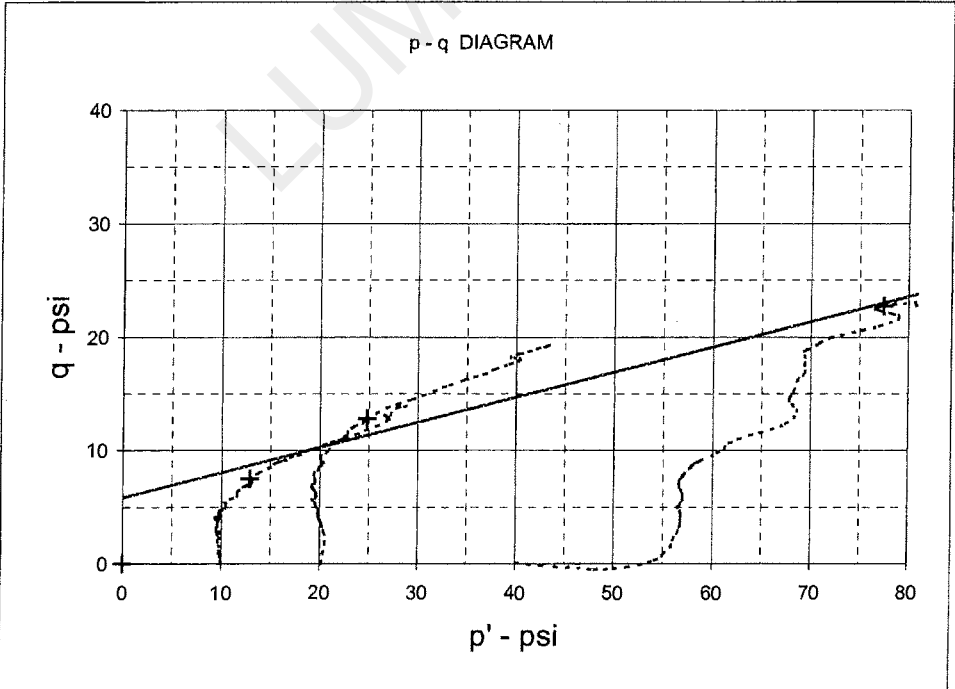
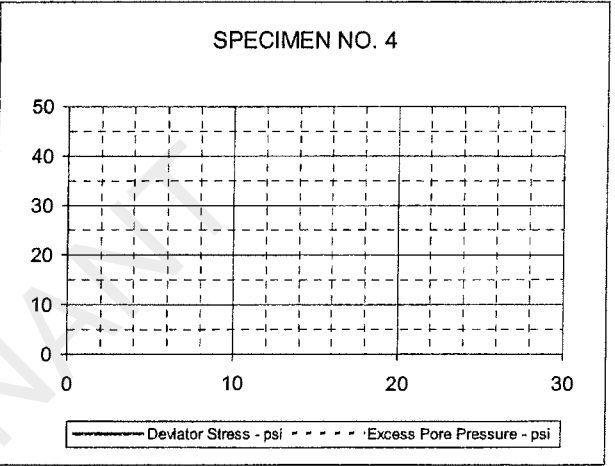
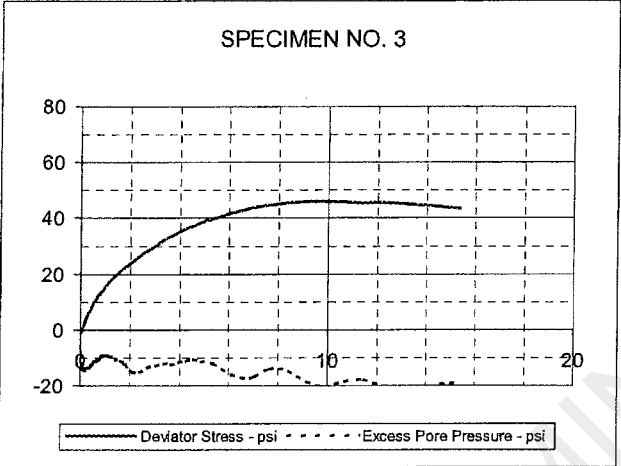
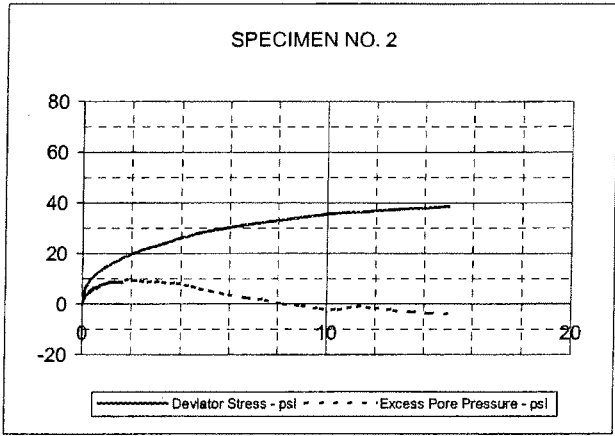
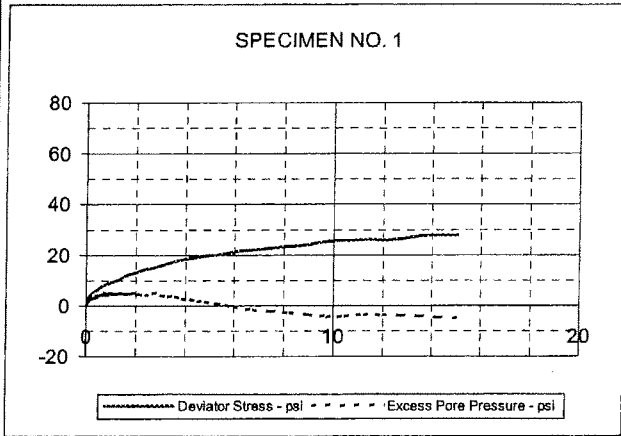

EFFECTIVE STRESS PARAMETERS	$R^2 = 0.97$	α (deg) = 12.5	a (psi) = 5.8
PROJECT: Luminant East Ash Disposal		TYPE OF TEST & NO: CU with PP	
PROJECT NO: G 2972 - 08		ETTL ENGINEERS & CONSULTANTS	PLATE: B.2
DESCRIPTION: Tan, Brown & Red Sandy Lean Clay			

G 2972-08, B-13, 3'-10' Fill

TRIAXIAL SHEAR TEST REPORT

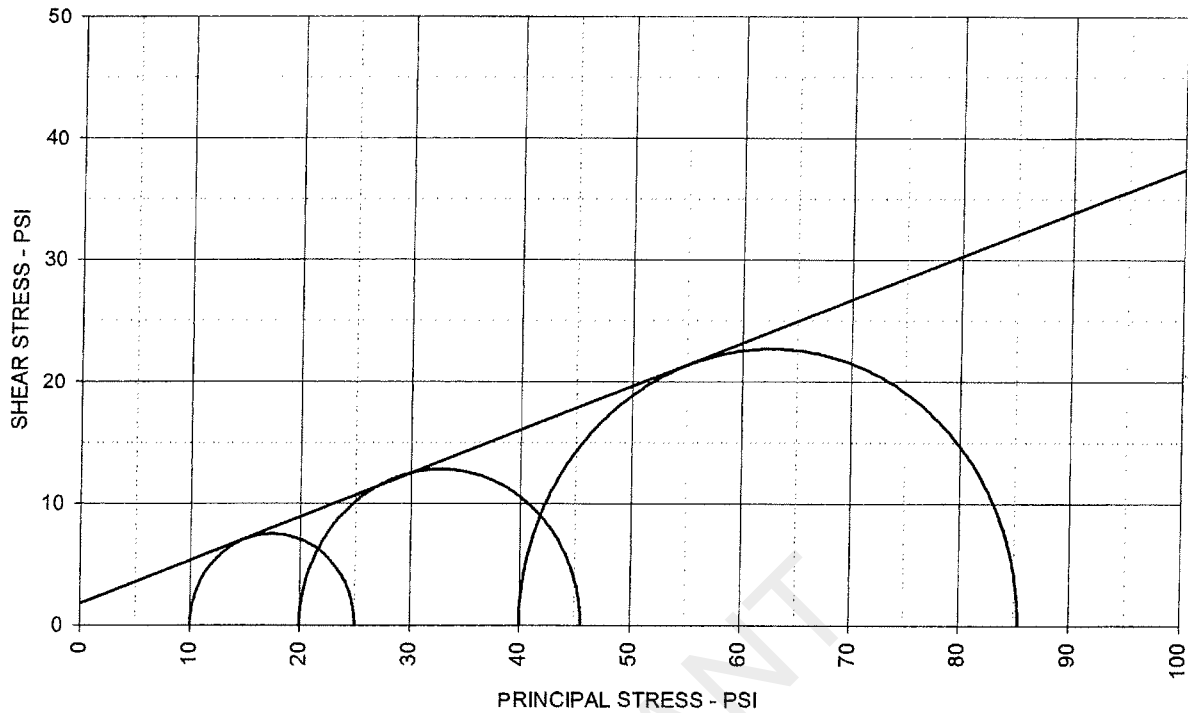

TOTAL STRESS PARAMETERS

$\phi = 19.6 \text{ deg}$

$c = 1.8 \text{ psi}$

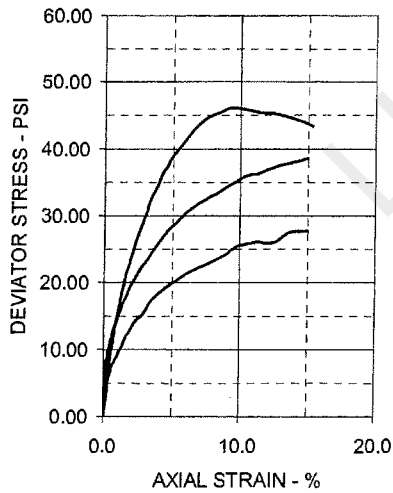

SPECIMEN NO.	1	2	3	4
INITIAL				
Moisture Content - %	15.8	16.6	15.9	
Dry Density - pcf	113.0	115.0	112.5	
Diameter - inches	2.04	2.01	2.06	
Height - inches	4.44	4.44	4.54	
AT TEST				
Final Moisture - %	18.1	18.1	17.6	
Dry Density - pcf	114.0	116.9	115.1	
Calculated Diameter (In.)	2.02	2.00	2.04	
Height - inches	4.40	4.40	4.49	
Effect. Cell Pressure - psi	10.0	20.0	40.0	
Failure Stress - psi	15.00	25.60	45.40	
Total Pore Pressure - psi	54.6	58.0	35.2	
Strain Rate - Inches/min.	0.00050	0.00050	0.00050	
Failure Strain - %	2.7	3.9	8.5	
σ_1 Failure - psi	25.00	45.60	85.40	
σ_3 Failure - psi	10.00	20.00	40.00	

TEST DESCRIPTION

TYPE OF TEST & NO: CU with PP
 SAMPLE TYPE: Possible Fill Sample
 DESCRIPTION: Tan, Brown & Red Sandy Lean Clay
 Sampled on Site, B-13 3' to 10' deep
 ASSUMED SPECIFIC GRAVITY: 2.7 + 40 Sieve
 LL: PL: PI: Percent -200:
 REMARKS: Both Ends & Diameter Trimmed + # 4 Sieve

PROJECT INFORMATION

PROJECT: Luminant East Ash Disposal
 LOCATION: Rusk County, Texas
 PROJECT NO: G 2972 - 08
 CLIENT:
 November 2008

ETTL ENGINEERS & CONSULTANTS

PLATE: B.3

PROJECT INFORMATION

PROJECT: Luminant East Ash Disposal
LOCATION: Rock County, Texas
PROJECT NO: G 2872 - 08
CLIENT:
November 2008

TRIAXIAL TEST PROGRAM BY GARRY H. GREGORY, P.E.

ALL RIGHTS RESERVED - UNAUTHORIZED USE PROHIBITED
VERSION 1.0 - AUGUST 1998 - REVISED MARCH 24, 1999

THIS COPY LICENSED TO:
ETTL ENGINEERS AND CONSULTANTS, INC.
1717 East Erwin
Tyler, TX 75702

TEST DESCRIPTION

TYPE OF TEST & NO: CU with PF
SAMPLE TYPE: Native Sample
DESCRIPTION: Gray, Tan & Redd. Br Sandy Clay w/ some Gravel
Sampled on Site: B-2, 8" to 20" deep
ASSUMED SPECIFIC GRAVITY: 2.7 + 40 Sieve
LL: PL: PI: Percent -200:
REMARKS: Both Ends & Diameter Trimmed + # 4 Sieve

PLATE: B.1

PLATE: B.2

PLATE: B.3

Number of Specimens = 3

SPECIMEN DATA
SPECIMEN NO. 1

	initial	final	Diameter		Height	
Moist soil & Tare :	479.50 g	630.20 g	top	2.08 in	Ht 1	4.25 in
Dry soil and Tare :	429.60 g	548.70 g	mid	2.08 in	Ht 2	4.25 in
Tare :	129.70 g	128.00 g	bot	2.08 in	Ht 3	4.25 in
Moisture content :	%	%	Avg	2.08 in	Ht4	4.25 in
Weight:	496.8 g				Avg Ht	in
Change in Ht due to saturation :		-0.014 in	Initial specimen vol :			cc
Change in Ht due to consolidation :		0.005 in	At test specimen vol :			cc
Change in pipet vol due to consolidation :		0.6 cc	Initial dry density :			pcf
Saturation Parameter " B " =	0.96		At test dry density:			pcf
Strain Rate (in/min) =	0.0005	Failure Strain % =	2.4	Effective Cell Pressure (psi) =		
σ_1' Failure (psi) =	36.26	σ_1 Failure (psi) =		Estimated v =	0.35	
σ_3' Failure (psi) =	8.24	σ_3 Failure (psi) =		Back Pressure (psi) =	50.0	
ΔU =		Total Pore Pressure =	51.8	Cell Pressure (psi) =	60.0	

SPECIMEN NO. 2

	initial	final	Diameter		Height	
Moist soil & Tare :	505.50 g	616.20 g	top	2.08 in	Ht 1	4.40 in
Dry soil and Tare :	451.40 g	537.50 g	mid	2.08 in	Ht 2	4.40 in
Tare :	114.00 g	102.60 g	bot	2.08 in	Ht 3	4.40 in
Moisture content :	%	%	Avg	2.08 in	Ht4	4.40 in
Weight:	511.6 g				Avg Ht	in
Change in Ht due to saturation :		0.01 in	Initial specimen vol :			cc
Change in Ht due to consolidation :		-0.048 in	At test specimen vol :			cc
Change in pipet vol due to consolidation :		7.0 cc	Initial dry density :			pcf
Saturation Parameter " B " =	0.96		At test dry density:			pcf
Strain Rate (in/min) =	0.0005	Failure Strain % =	3.4	Effective Cell Pressure (psi) =		
σ_1' Failure (psi) =	48.53	σ_1 Failure (psi) =		Estimated v =	0.35	
σ_3' Failure (psi) =	13.88	σ_3 Failure (psi) =		Back Pressure (psi) =	50.0	
ΔU =		Total Pore Pressure =	56.1	Cell Pressure (psi) =	70.0	

SPECIMEN NO. 3

	initial	final	Diameter		Height	
Moist soil & Tare :	414.70 g	721.50 g	top	2.11 in	Ht 1	4.62 in
Dry soil and Tare :	381.70 g	652.20 g	mid	2.11 in	Ht 2	4.62 in
Tare :	102.50 g	139.10 g	bot	2.11 in	Ht 3	4.62 in
Moisture content :	%	%	Avg	2.11 in	Ht4	4.62 in
Weight:	578.6 g				Avg Ht	in
Change in Ht due to saturation :		-0.021 in	Initial specimen vol :			cc
Change in Ht due to consolidation :		-0.018 in	At test specimen vol :			cc
Change in pipet vol due to consolidation :		5.4 cc	Initial dry density :			pcf
Saturation Parameter " B " =	0.99		At test dry density:			pcf
Strain Rate (in/min) =	0.0005	Failure Strain % =	4.6	Effective Cell Pressure (psi) =		
σ_1' Failure (psi) =	95.68	σ_1 Failure (psi) =		Estimated v =	0.35	
σ_3' Failure (psi) =	25.40	σ_3 Failure (psi) =		Back Pressure (psi) =	50.0	
ΔU =		Total Pore Pressure =	64.6	Cell Pressure (psi) =	90.0	

TRIAxIAL SHEAR TEST REPORT

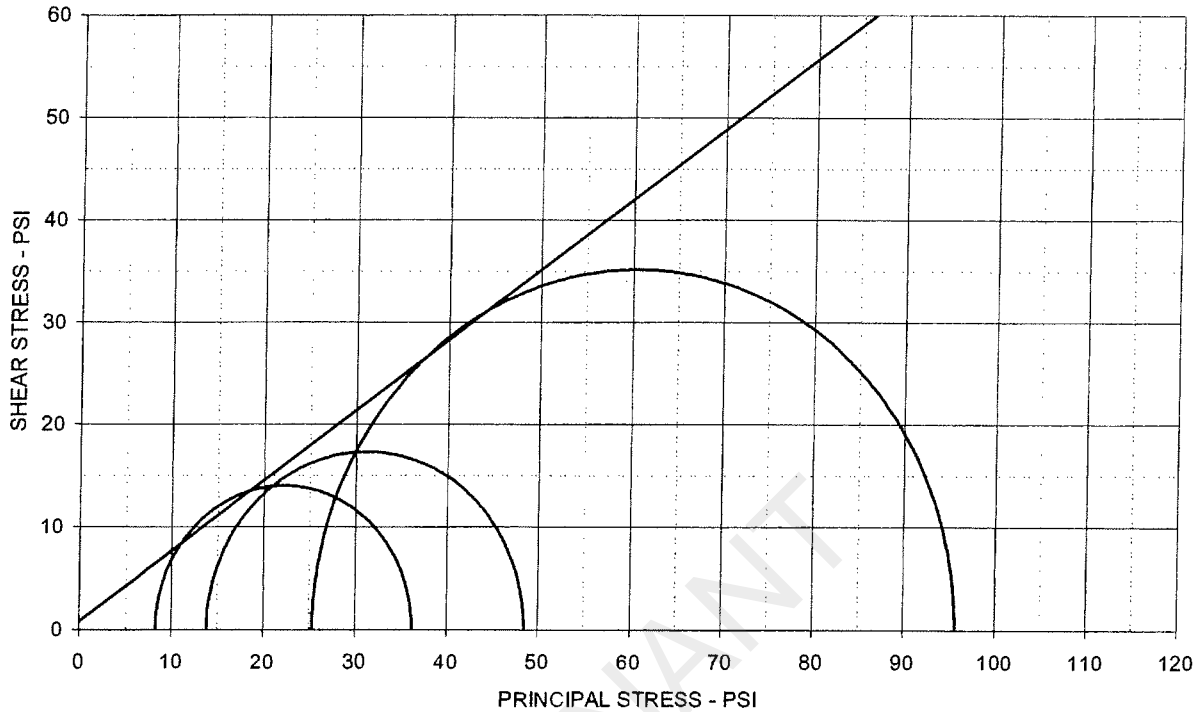

EFFECTIVE STRESS PARAMETERS

$\phi' = 34.4 \text{ deg}$

$c' = 0.8 \text{ psi}$

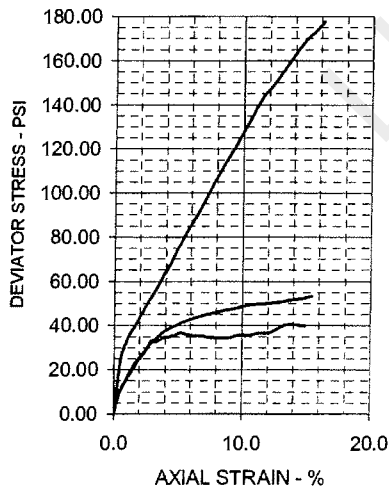

SPECIMEN NO.

1 2 3 4

INITIAL

Moisture Content - %	16.6	16.0	11.8
Dry Density - pcf	112.3	112.1	122.3
Diameter - inches	2.08	2.08	2.11
Height - inches	4.25	4.40	4.62

AT TEST

Final Moisture - %	19.4	18.1	13.5
Dry Density - pcf	112.6	115.3	124.9
Calculated Diameter (in.)	2.08	2.07	2.10
Height - inches	4.24	4.37	4.58
Effect. Cell Pressure - psi	10.0	20.0	40.0
Failure Stress - psi	28.02	34.65	70.28
Total Pore Pressure - psi	51.8	56.1	64.6
Strain Rate - inches/min.	0.00050	0.00050	0.00050
Failure Strain - %	2.4	3.4	4.6
σ_1' Failure - psi	36.26	48.53	95.68
σ_3' Failure - psi	8.24	13.88	25.40

TEST DESCRIPTION

PROJECT INFORMATION

TYPE OF TEST & NO: CU with PP
 SAMPLE TYPE: Native Sample
 DESCRIPTION: Gray, Tan & Redd. Br Sandy Clay w/ some Gravel
 Sampled on Site, B-2 8' to 20' deep
 ASSUMED SPECIFIC GRAVITY: 2.7 + 40 Sieve
 LL: PL: PI: Percent -200:
 REMARKS: Both Ends & Diameter Trimmed + # 4 Sieve
 G 2972-08, B-2, 0' to 20' Native

PROJECT: Luminant East Ash Disposal
 LOCATION: Rusk County, Texas
 PROJECT NO: G 2972 - 08
 CLIENT:
 November 2008

ETTL ENGINEERS & CONSULTANTS

PLATE: B.1

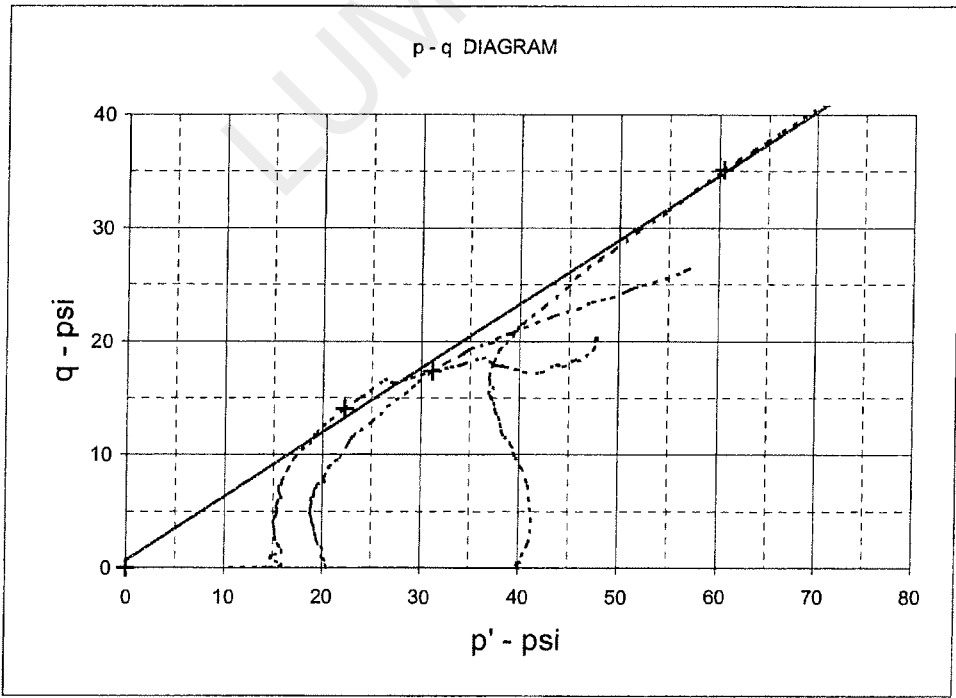
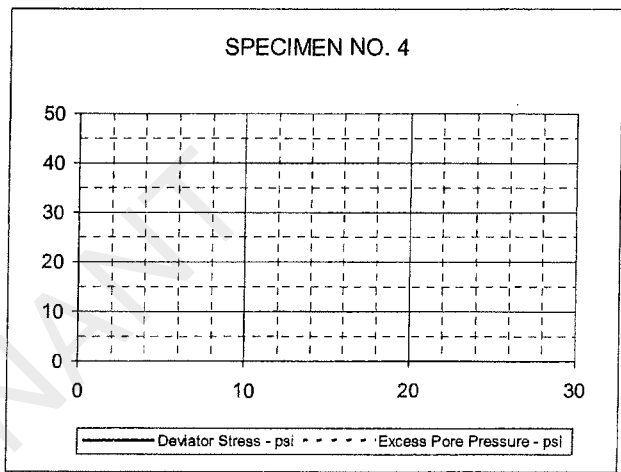
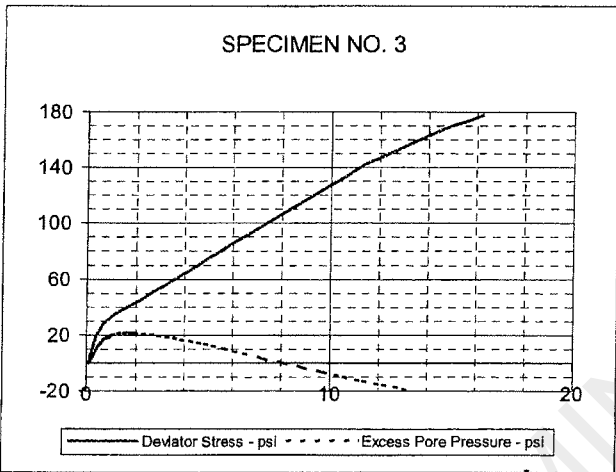
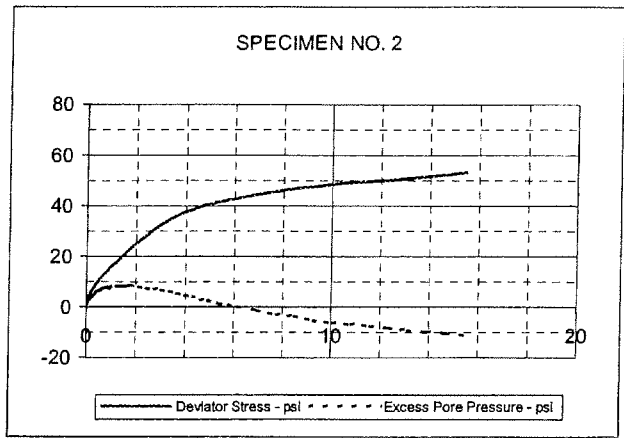
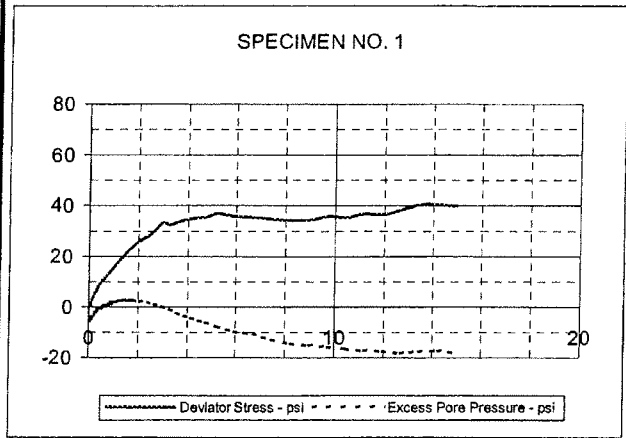

EFFECTIVE STRESS PARAMETERS	$R^2 = 0.99$	α (deg) = 29.5	a (psi) = 0.7
PROJECT: Luminant East Ash Disposal		TYPE OF TEST & NO: CU with PP	
PROJECT NO: G 2972 - 08		ETTL ENGINEERS & CONSULTANTS	PLATE: B.2
DESCRIPTION: Gray, Tan & Redd. Br Sandy Clay w/ some Gravel			

G 2972-08, B-2, 8'-20' Native

TRIAxIAL SHEAR TEST REPORT

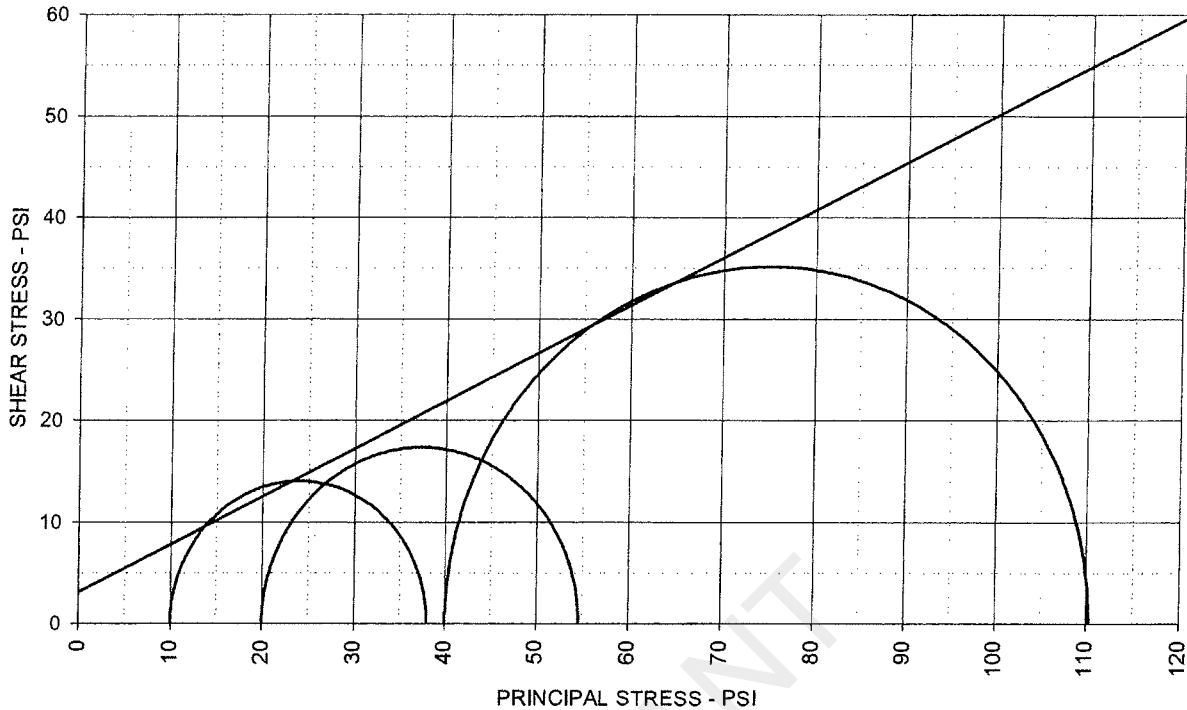

TOTAL STRESS PARAMETERS

$\phi = 25.2 \text{ deg}$

$c = 3.1 \text{ psi}$

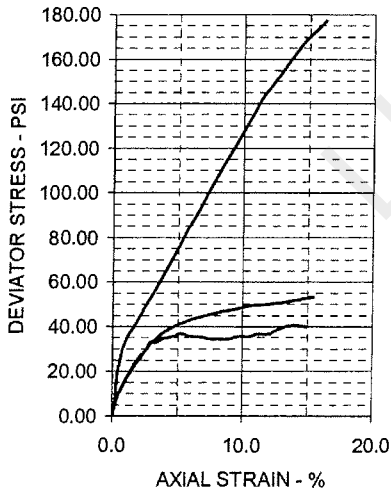

SPECIMEN NO.	1	2	3	4
	INITIAL			
Moisture Content - %	16.6	16.0	11.8	
Dry Density - pcf	112.3	112.1	122.3	
Diameter - inches	2.08	2.08	2.11	
Height - inches	4.25	4.40	4.62	
AT TEST				
Final Moisture - %	19.4	18.1	13.5	
Dry Density - pcf	112.6	115.3	124.9	
Calculated Diameter (in.)	2.08	2.07	2.10	
Height - inches	4.24	4.37	4.58	
Effect. Cell Pressure - psi	10.0	20.0	40.0	
Failure Stress - psi	28.02	34.65	70.28	
Total Pore Pressure - psi	51.8	56.1	64.6	
Strain Rate - inches/min.	0.00050	0.00050	0.00050	
Failure Strain - %	2.4	3.4	4.6	
σ_1 Failure - psi	38.02	54.65	110.28	
σ_3 Failure - psi	10.00	20.00	40.00	

TEST DESCRIPTION

TYPE OF TEST & NO: CU with PP
 SAMPLE TYPE: Native Sample
 DESCRIPTION: Gray, Tan & Redd. Br Sandy Clay w/ some Gravel
 Sampled on Site, B-2 8' to 20' deep
 ASSUMED SPECIFIC GRAVITY: 2.7 + 40 Sieve
 LL: PL: PI: Percent -200:
 REMARKS: Both Ends & Diameter Trimmed + # 4 Sieve

PROJECT INFORMATION

PROJECT: Luminant East Ash Disposal
 LOCATION: Rusk County, Texas
 PROJECT NO: G 2972 - 08
 CLIENT:
 November 2008

ETTL ENGINEERS & CONSULTANTS

PLATE: B.3

PROJECT INFORMATION

PROJECT: Luminant East Ash Disposal
LOCATION: Rock County, Texas
PROJECT NO: G 2972-08
CLIENT:
November, 2008

TRIAxIAL TEST PROGRAM BY GARRY H. GREGORY, P.E.

ALL RIGHTS RESERVED - UNAUTHORIZED USE PROHIBITED
VERSION 1.0 - AUGUST 1998 - REVISED MARCH 24, 1999

THIS COPY LICENSED TO:
ETTL ENGINEERS AND CONSULTANTS, INC.
1717 East Erwin
Tyler, TX 75702

TEST DESCRIPTION

TYPE OF TEST & NO: CUJ with PP
SAMPLE TYPE: Possible Fill Sample
DESCRIPTION: Tan & Red Sandy Lean Clay w/ Roots
Sampled on Site: B-1 3' to 10' deep
ASSUMED SPECIFIC GRAVITY: 2.7 + 40 Sieve
LL: PL: PI: Percent -200
REMARKS: Both Ends & Diameter Trimmed + # 4 Sieve

PLATE: B.1

PLATE: B.2

PLATE: B.3

Number of Specimens = 3

SPECIMEN DATA

SPECIMEN NO. 1

	initial	final	Diameter		Height	
Moist soil & Tare :	539.30 g	625.10 g	top	2.07 in	Ht 1	4.23 in
Dry soil and Tare :	492.00 g	546.00 g	mid	2.07 in	Ht 2	4.23 in
Tare :	127.40 g	126.90 g	bot	2.07 in	Ht 3	4.23 in
Moisture content :			Avg	2.07 in	Ht4	4.23 in
Weight:	493.2 g				Avg Ht	
Change in Ht due to saturation :		0.02 in	Initial specimen vol :			cc
Change in Ht due to consolidation :		-0.005 in	At test specimen vol :			cc
Change in pipet vol due to consolidation :		3.2 cc	Initial dry density :			pcf
Saturation Parameter " B " =	0.97		At test dry density:			pcf
Strain Rate (in/min) =	0.0005	Failure Strain % =	1.4	Effective Cell Pressure (psi) =		
σ_1 ' Failure (psi) =	29.29	σ_1 Failure (psi) =		Estimated v =	0.35	
σ_3 ' Failure (psi) =	6.35	σ_3 Failure (psi) =		Back Pressure (psi) =	50.0	
ΔU =		Total Pore Pressure =	53.7	Cell Pressure (psi) =	60.0	

SPECIMEN NO. 2

	initial	final	Diameter		Height	
Moist soil & Tare :	543.00 g	591.00 g	top	2.01 in	Ht 1	4.25 in
Dry soil and Tare :	492.70 g	519.10 g	mid	2.01 in	Ht 2	4.25 in
Tare :	135.60 g	124.60 g	bot	2.01 in	Ht 3	4.25 in
Moisture content :			Avg	2.01 in	Ht4	4.25 in
Weight:	462.2 g				Avg Ht	
Change in Ht due to saturation :		-0.009 in	Initial specimen vol :			cc
Change in Ht due to consolidation :		-0.033 in	At test specimen vol :			cc
Change in pipet vol due to consolidation :		4.2 cc	Initial dry density :			pcf
Saturation Parameter " B " =	0.99		At test dry density:			pcf
Strain Rate (in/min) =	0.0005	Failure Strain % =	3.0	Effective Cell Pressure (psi) =		
σ_1 ' Failure (psi) =	40.52	σ_1 Failure (psi) =		Estimated v =	0.35	
σ_3 ' Failure (psi) =	14.53	σ_3 Failure (psi) =		Back Pressure (psi) =	50.0	
ΔU =		Total Pore Pressure =	55.5	Cell Pressure (psi) =	70.0	

SPECIMEN NO. 3

	initial	final	Diameter		Height	
Moist soil & Tare :	431.00 g	528.40 g	top	2.10 in	Ht 1	4.28 in
Dry soil and Tare :	385.90 g	558.80 g	mid	2.10 in	Ht 2	4.28 in
Tare :	105.00 g	119.40 g	bot	2.10 in	Ht 3	4.28 in
Moisture content :			Avg	2.10 in	Ht4	4.28 in
Weight:	510.5 g				Avg Ht	
Change in Ht due to saturation :		-0.017 in	Initial specimen vol :			cc
Change in Ht due to consolidation :		-0.039 in	At test specimen vol :			cc
Change in pipet vol due to consolidation :		4.6 cc	Initial dry density :			pcf
Saturation Parameter " B " =	0.97		At test dry density:			pcf
Strain Rate (in/min) =	0.0005	Failure Strain % =	3.0	Effective Cell Pressure (psi) =		
σ_1 ' Failure (psi) =	104.13	σ_1 Failure (psi) =		Estimated v =	0.35	
σ_3 ' Failure (psi) =	42.71	σ_3 Failure (psi) =		Back Pressure (psi) =	50.0	
ΔU =		Total Pore Pressure =	47.3	Cell Pressure (psi) =	90.0	

TRIAxIAL SHEAR TEST REPORT

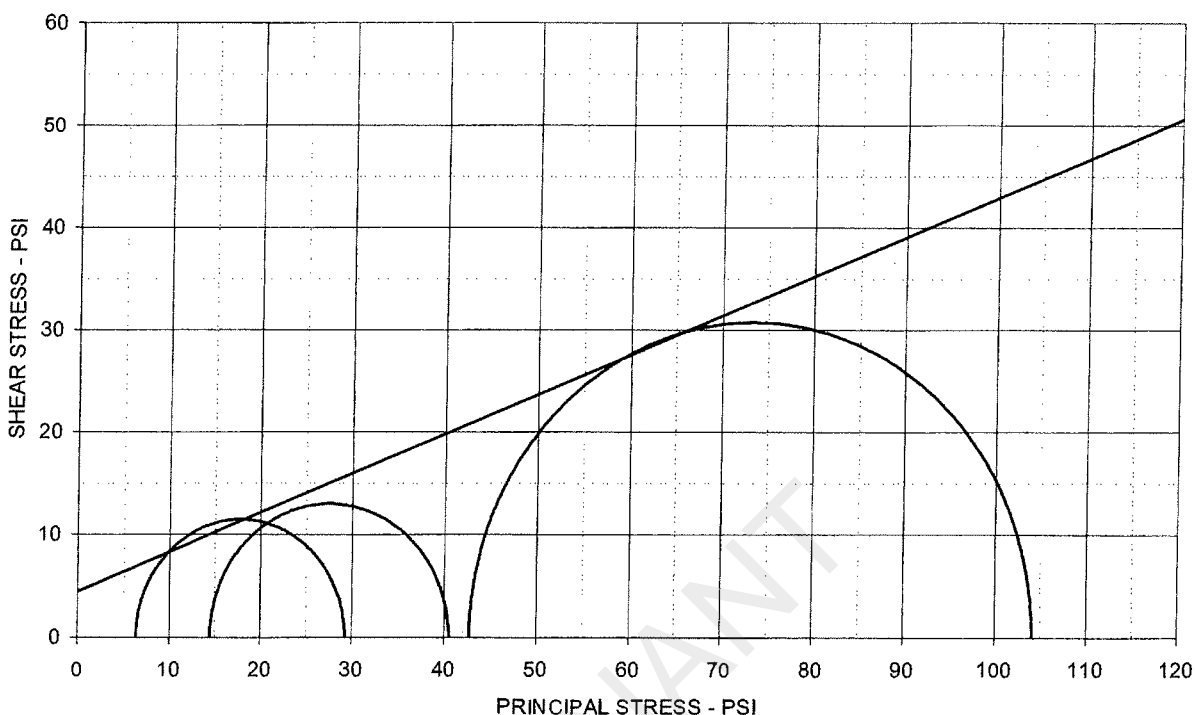

EFFECTIVE STRESS PARAMETERS		$\phi' =$ 21.0 deg	$c' =$ 4.5 psi			
	SPECIMEN NO.	1	2	3	4	
	INITIAL					
	Moisture Content - %	16.2	15.5	16.1		
	Dry Density - pcf	113.6	113.1	113.3		
	Diameter - Inches	2.07	2.01	2.10		
	Height - Inches	4.23	4.25	4.28		
	AT TEST					
	Final Moisture - %	18.3	18.2	15.8		
	Dry Density - pcf	115.2	115.3	115.5		
	Calculated Diameter (in.)	2.08	1.99	2.08		
Height - inches	4.24	4.21	4.22			
Effect. Cell Pressure - psi	10.0	20.0	40.0			
Failure Stress - psi	22.94	25.99	61.42			
Total Pore Pressure - psi	53.7	55.5	47.3			
Strain Rate - Inches/min.	0.00050	0.00050	0.00050			
Failure Strain - %	1.4	3.0	3.0			
σ_1' Failure - psi	29.29	40.52	104.13			
σ_3' Failure - psi	6.35	14.53	42.71			

TEST DESCRIPTION	PROJECT INFORMATION
TYPE OF TEST & NO: CU with PP SAMPLE TYPE: Possible Fill Sample DESCRIPTION: Tan & Red Sandy Lean Clay w/ Roots Sampled on Site, B-1 3' to 10' deep ASSUMED SPECIFIC GRAVITY: 2.7 + 40 Sieve LL: PL: Pi: Percent -200: REMARKS: Both Ends & Diameter Trimmed + # 4 Sieve G 2972-00, B-1, 3'-10' Fill	PROJECT: Luminant East Ash Disposal LOCATION: Rusk County, Texas PROJECT NO: G 2972 - 08 CLIENT: November 2008 <div style="display: flex; justify-content: space-between; margin-top: 10px;"> ETTL ENGINEERS & CONSULTANTS PLATE: B.1 </div>

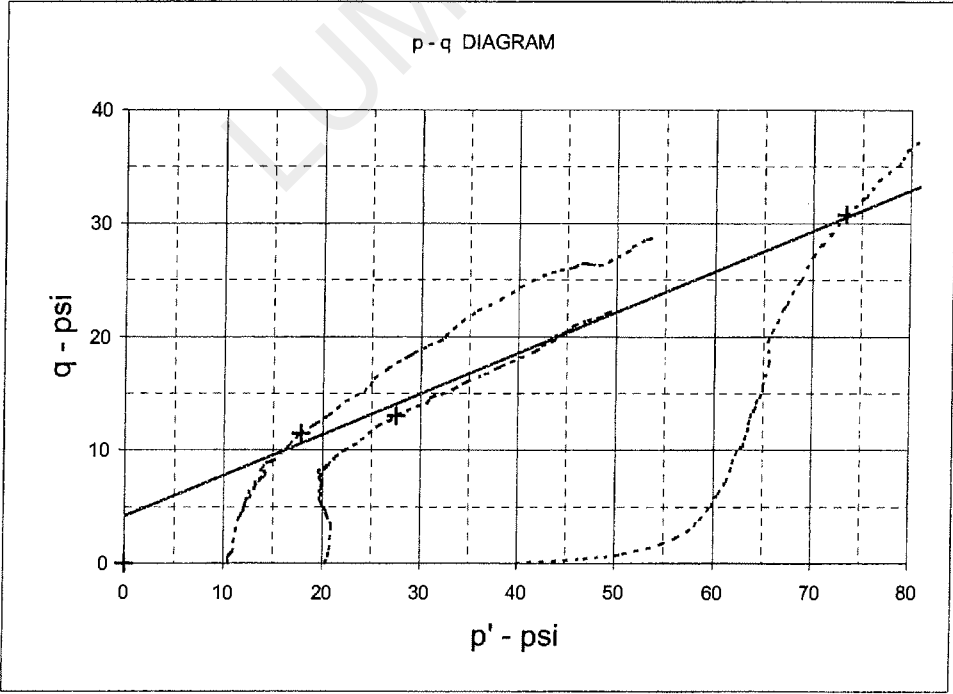
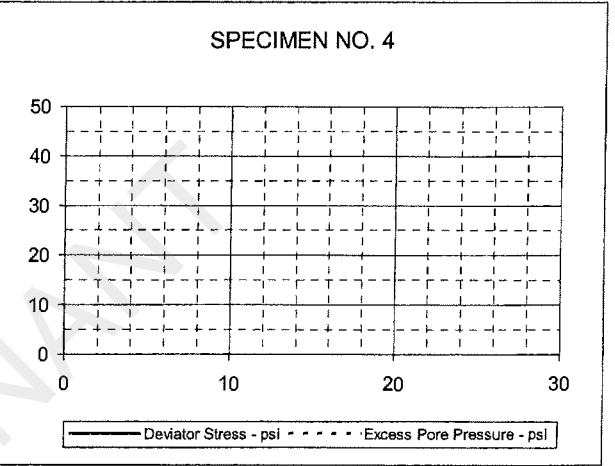
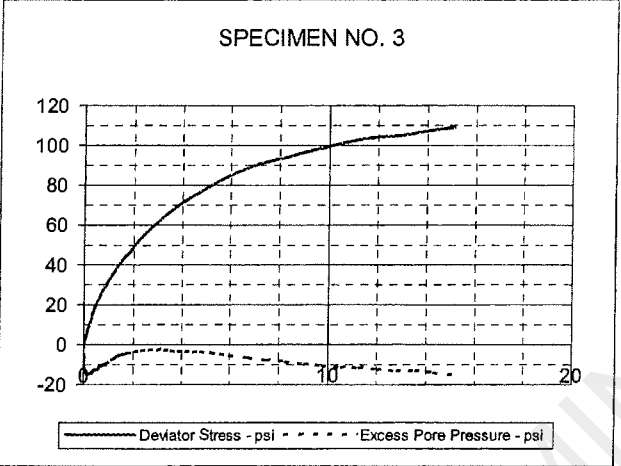
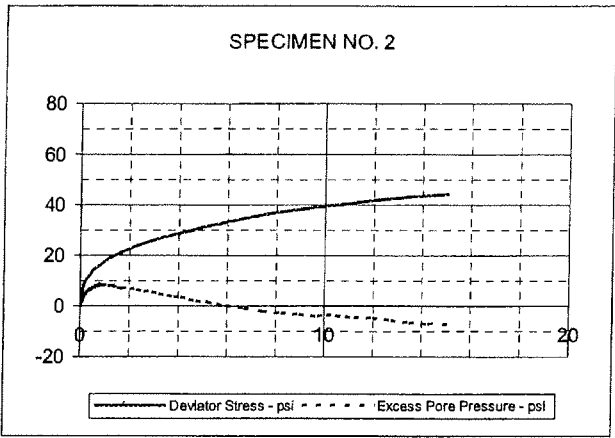
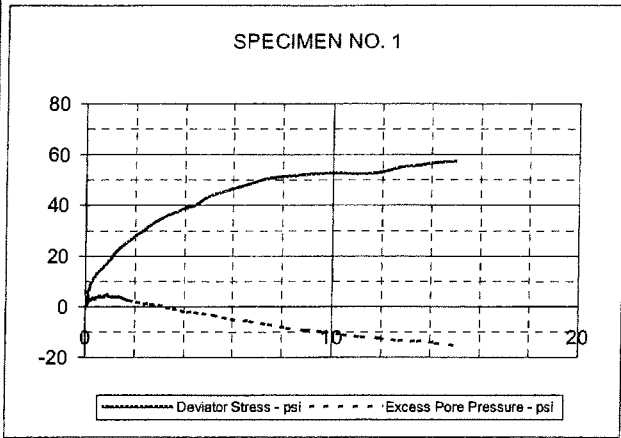

EFFECTIVE STRESS PARAMETERS	$R^2 = 0.99$	α (deg) = 19.7	a (psi) = 4.2
PROJECT: Luminant East Ash Disposal		TYPE OF TEST & NO: CU with PP	
PROJECT NO: G 2972 - 08		ETTL ENGINEERS & CONSULTANTS	PLATE: B.2
DESCRIPTION: Tan & Red Sandy Lean Clay w/ Roots			

G 2972-08, B-1, 3'-10' Fill

TRIAxIAL SHEAR TEST REPORT

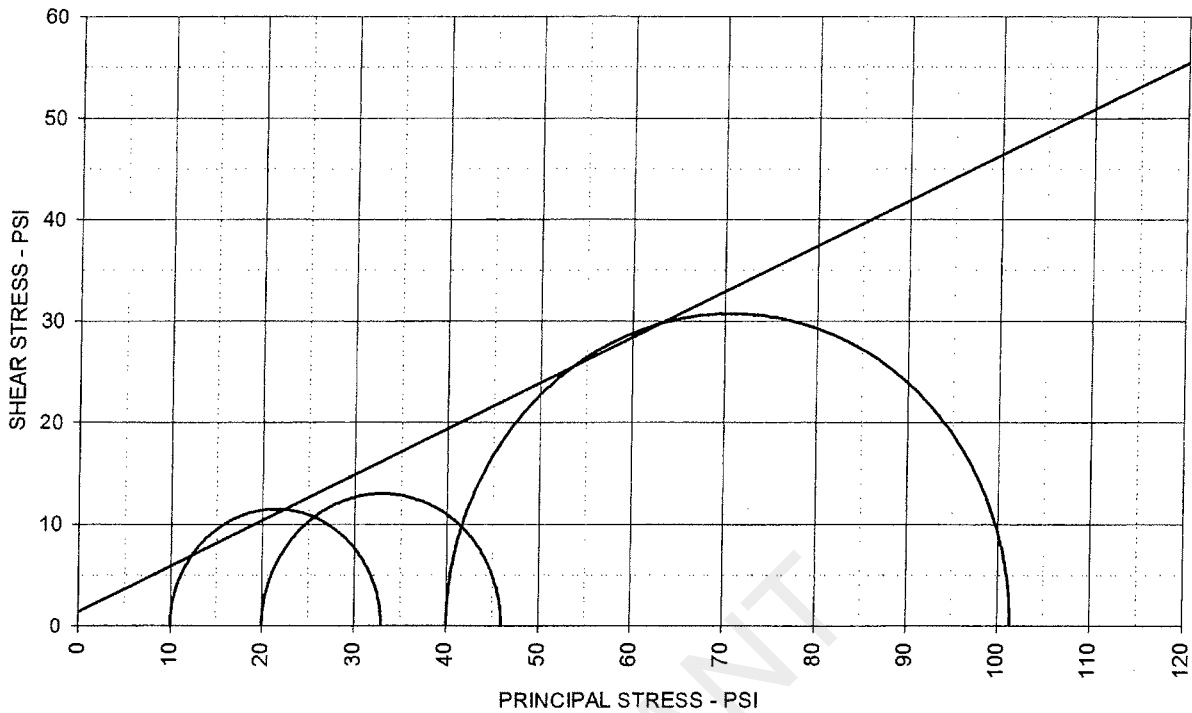

TOTAL STRESS PARAMETERS

$\phi = 24.2 \text{ deg}$

$c = 1.4 \text{ psi}$

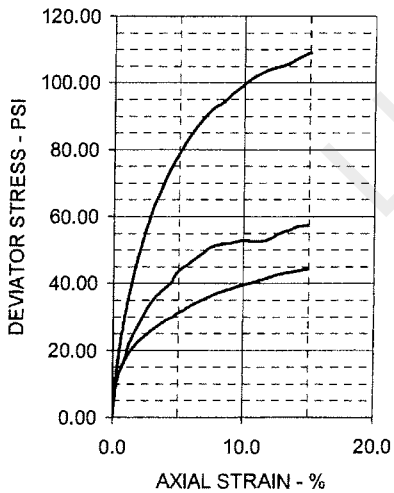

SPECIMEN NO.	1	2	3	4
INITIAL				
Moisture Content - %	16.2	15.5	16.1	
Dry Density - pcf	113.6	113.1	113.3	
Diameter - inches	2.07	2.01	2.10	
Height - inches	4.23	4.25	4.28	
AT TEST				
Final Moisture - %	18.3	18.2	15.8	
Dry Density - pcf	115.2	115.3	115.5	
Calculated Diameter (in.)	2.08	1.99	2.08	
Height - Inches	4.24	4.21	4.22	
Effect. Cell Pressure - psi	10.0	20.0	40.0	
Failure Stress - psi	22.94	25.99	61.42	
Total Pore Pressure - psi	53.7	55.5	47.3	
Strain Rate - Inches/min.	0.00050	0.00050	0.00050	
Failure Strain - %	1.4	3.0	3.0	
σ_1 Failure - psi	32.94	45.99	101.42	
σ_3 Failure - psi	10.00	20.00	40.00	

TEST DESCRIPTION

TYPE OF TEST & NO: CU with PP
 SAMPLE TYPE: Possible Fill Sample
 DESCRIPTION: Tan & Red Sandy Lean Clay w/ Roots
 Sampled on Site, B-1 3' to 10' deep
 ASSUMED SPECIFIC GRAVITY: 2.7 + 40 Sieve
 LL: PL: PI: Percent -200:
 REMARKS: Both Ends & Diameter Trimmed + # 4 Sieve

PROJECT INFORMATION

PROJECT: Luminant East Ash Disposal
 LOCATION: Rusk County, Texas
 PROJECT NO: G 2972 - 08
 CLIENT:
 November 2008

ETTL ENGINEERS & CONSULTANTS

PLATE: B.3

PERMANENT DISPOSAL POND - 5

LUMINANT

HYDROMETER AND MECHANICAL ANALYSIS OF SOIL BINDER, ASTM D422

PROJECT: Luminant Martin Lake, PDP 1-3
CLIENT: TXU
CONTRACTOR: not given
JOB No. : G 2810 - 08

REPORT No.:
DATE SAMPLED: February 2008
SAMPLED BY: E TTL Drill Crew
LOCATION: MLSES
SAMPLE No. :
DESCRIPTION: Gray & Dark Gray Bottom Ash
TECHNICIAN: M. Thompson
DATE: 04/15/08

RESULTS

Grain Diameter	% Retain
+2.0 mm	47.69
+0.05 mm	99.26
0.05 to 2.0 mm	51.57
0.002 to 0.05 mm	0.72
> 0.002 mm	0.02

WEIGHT OF SAMPLE (AIR DRY)	100.00
WEIGHT OF SAMPLE (OVEN DRY)	99.90
PERCENT RETAINED ON # 10	47.69
SPECIFIC GRAVITY	2.563

	SIEVE	WEIGHT	%RETAIN	GRAIN DIA	%PASSING
Mc Hydrom	40	54.66	76.31	0.425	23.69
Tare Wt	29.89	60	71.63	0.250	14.80
Wet Wt.	68.94	100	84.45	0.150	8.09
Dry Wt	68.90	140	90.93	0.105	4.70
MC	0.1025%	200	93.54	0.075	3.33

TEMP (C)	HYDROMETER CORRECTION	HYDROMETER READING	CORRECTED READING	L.Hydrom FACTOR	K. Diam. FACTOR	a. SP.GR. FACTOR	TIME (MIN)	GRAIN DIA (MM)	% SOIL PASSING
21.5	5.7	11.0	5.3	15.5	0.0141	1.02	0.5	0.0787	2.82
21.5	5.7	8.0	2.3	16	0.0141	1.02	1	0.0566	1.21
21.5	5.7	6.8	1.1	16.1	0.0141	1.02	2	0.0401	0.57
21.5	5.7	6.2	0.5	16.3	0.0141	1.02	5	0.0255	0.25
21.5	5.7	6.0	0.3	16.3	0.0141	1.02	15	0.0147	0.15
21.5	5.7	5.8	0.1	16.3	0.0141	1.02	30	0.0104	0.04
21.5	5.7	5.8	0.1	16.3	0.0141	1.02	60	0.0074	0.04
21.5	5.7	5.8	0.1	16.3	0.0141	1.02	250	0.0036	0.04
22.0	5.6	5.6	0.0	16.3	0.0140	1.02	1440	0.0015	0.02

SPECIFIC GRAVITY	BOTTLE #	Bottle Wt	Bott & Water	WaterTemp	Corr. Soil	Bott, S & Water	WaterTemp	Specif. Grav	
Air dry Sample(gr)	100	10	188.06	686.13	22.5	99.90	747.18	21.5	2.563

Sieve % Pass	Sieve Size	Grams Retain	% Pass
	2"	0.00	100.00
	1-1/2"	89.00	98.47
Air Dry Start Wt.:	1"	215.04	96.31
5836.8	3/4"	288.14	95.06
Dry Start Wt.:	3/8"	709.78	87.83
5830.82	No 4	1510.97	74.09
	No 10	2780.46	52.31

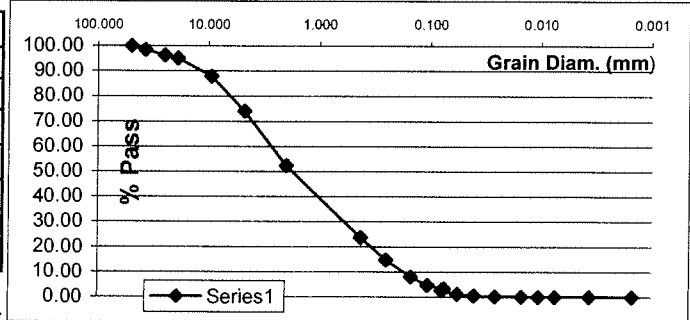

Remarks:

HYDROMETER AND MECHANICAL ANALYSIS OF SOIL BINDER, ASTM D422

PROJECT: Luminant Martin Lake, PDP 1-3
CLIENT: TXU
CONTRACTOR: not given
JOB No. : G 2810 - 08

REPORT No.:
DATE SAMPLED: February 2008
SAMPLED BY: E TTL Drill Crew
LOCATION: B-9, 1'-3'
SAMPLE No. :
DESCRIPTION: Gray Ash (Cementing)
TECHNICIAN: H. Walka
DATE: 03/14/08

RESULTS

		Grain Diameter	
% Retain	+2.0 mm		0.08
% Retain	+0.05 mm		41.35
% Passing	0.05 to 2.0 mm		41.27
% Passing	0.002 to 0.05 mm		56.63
% Passing	> 0.002 mm		2.02

WEIGHT OF SAMPLE (AIR DRY)	100.00
WEIGHT OF SAMPLE (OVEN DRY)	99.73
PERCENT RETAINED ON # 10	0.08
SPECIFIC GRAVITY	2.761

	SIEVE	WEIGHT	%RETAIN	GRAIN DIA	%PASSING
Mc Hydrom	40	0.92	1.00	0.425	99.00
Tare Wt	29.50	60	1.92	0.250	98.00
Wet Wt	62.41	100	3.90	0.150	96.01
Dry Wt	62.32	140	7.07	0.105	92.84
MC	0.2742%	200	10.67	0.075	89.23

TEMP (C)	HYDROMETER CORRECTION	HYDROMETER READING	CORRECTED READING	L. Hydrom FACTOR	K. Diam. FACTOR	a. SP. GR. FACTOR	TIME (MIN)	GRAIN DIA (MM)	% SOIL PASSING
23.0	5.2	65.0	59.8	6.6	0.0138	0.98	0.5	0.0502	58.67
23.0	5.2	63.0	57.8	7	0.0138	0.98	1	0.0365	56.71
23.0	5.2	53.0	47.8	8.6	0.0138	0.98	2	0.0286	46.89
23.0	5.2	32.0	26.8	12	0.0138	0.98	5	0.0214	26.27
22.5	5.4	10.0	4.6	15.6	0.0140	0.98	15	0.0142	4.51
22.5	5.4	8.5	3.1	15.8	0.0140	0.98	30	0.0101	3.04
22.5	5.4	8.0	2.6	16	0.0140	0.98	60	0.0072	2.55
22.0	5.6	8.0	2.4	16	0.0140	0.98	250	0.0035	2.39
22.0	5.6	7.5	1.9	16.1	0.0140	0.98	1440	0.0015	1.90

SPECIFIC GRAVITY	BOTTLE #	Bottle Wt	Bott & Water	WaterTemp	Corr. Soil	Bott, S & Water	WaterTemp	Specif. Grav	
Air dry Sample(gr)	50	7	179.97	678.12	22.5	49.86	709.93	22.5	2.761

Sieve % Pass	Sieve Size	Grams Retain	% Pass
Air Dry Start Wt.:	1-1/2"	0.00	100.00
334.9	1"	0.00	100.00
Dry Start Wt.:	3/4"	0.00	100.00
333.98	No 4	0.00	100.00
	No 10	0.26	99.92

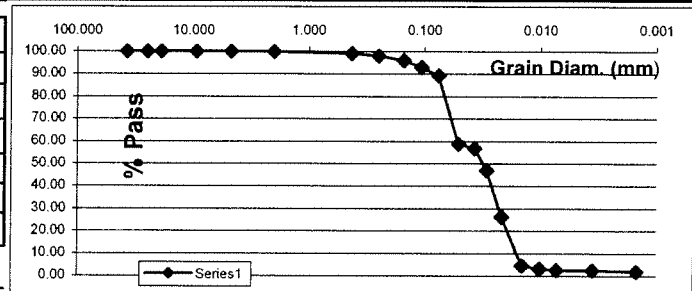

Remarks:

HYDROMETER AND MECHANICAL ANALYSIS OF SOIL BINDER, ASTM D422

PROJECT: Luminant Martin Lake, PDP 1-3
 CLIENT: TXU
 CONTRACTOR: not given
 JOB No. : G 2810 - 08

REPORT No.:
 DATE SAMPLED: February 2008
 SAMPLED BY: E TTL Drill Crew
 LOCATION: B-7, 13'-15'
 SAMPLE No. :
 DESCRIPTION: Gray Ash
 TECHNICIAN: H. Walka
 DATE: 03/14/08

RESULTS

Grain Diameter	% Retain	% Passing
+2.0 mm	59.89	
+0.05 mm	92.28	
0.05 to 2.0 mm		32.39
0.002 to 0.05 mm		4.63
> 0.002 mm		3.09

WEIGHT OF SAMPLE (AIR DRY)	50.00
WEIGHT OF SAMPLE (OVEN DRY)	49.81
PERCENT RETAINED ON # 10	59.89
SPECIFIC GRAVITY	2.655

	SIEVE	WEIGHT	%RETAIN	GRAIN DIA	%PASSING
Mc Hydrom	40	25.25	80.22	0.425	19.78
Tare Wt	30.03	60	29.25	0.250	16.56
Wet Wt.	45.86	100	32.74	0.150	13.75
Dry Wt.	45.80	140	35.11	0.105	11.84
MC	0.3805%	200	36.67	0.075	10.58

TEMP (C)	HYDROMETER CORRECTION	HYDROMETER READING	CORRECTED READING	L.Hydrom FACTOR	K. Diam. FACTOR	a. SP.GR. FACTOR	TIME (MIN)	GRAIN DIA (MM)	% SOIL PASSING
22.0	5.6	17.5	11.9	14.5	0.0140	1.00	0.5	0.0752	9.61
22.0	5.6	15.5	9.9	14.8	0.0140	1.00	1	0.0537	8.00
22.0	5.6	14.0	8.4	15	0.0140	1.00	2	0.0383	6.79
22.0	5.6	13.5	7.9	15.2	0.0140	1.00	5	0.0244	6.39
22.0	5.6	13.0	7.4	15.2	0.0140	1.00	15	0.0141	5.99
21.5	5.7	12.5	6.8	15.3	0.0141	1.00	30	0.0101	5.46
21.5	5.7	12.0	6.3	15.3	0.0141	1.00	60	0.0071	5.05
22.0	5.6	10.5	4.9	15.6	0.0140	1.00	250	0.0035	3.97
22.0	5.6	9.0	3.4	15.8	0.0140	1.00	1440	0.0015	2.77

SPECIFIC GRAVITY	BOTTLE #	Bottle Wt	Bott & Water	WaterTemp	Corr. Soil	Bott, S & Water	WaterTemp	Specif. Grav	
Air dry Sample(gr)	25	4	179.25	677.26	22.5	24.91	692.79	22.5	2.655

Sieve % Pass	Sieve Size	Grams Retain	% Pass
Air Dry Start Wt.:	1-1/2"	0.00	100.00
243.3	1"	0.00	100.00
Dry Start Wt.:	3/4"	0.00	100.00
242.38	3/8"	13.45	94.47
	No 4	77.42	68.18
	No 10	145.71	40.11

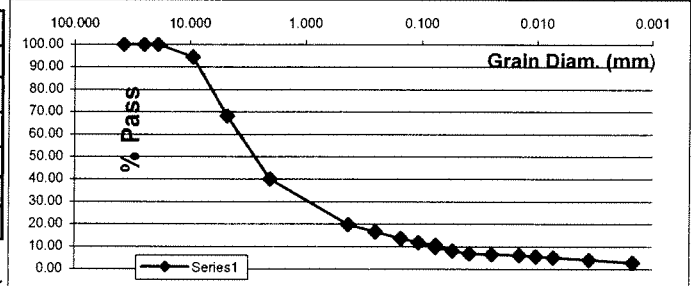

Remarks:

HYDROMETER AND MECHANICAL ANALYSIS OF SOIL BINDER, ASTM D422

PROJECT: Luminant Martin Lake, PDP 1-3
CLIENT: TXU
CONTRACTOR: not given
JOB No. : G 2810 - 08

REPORT No.:
DATE SAMPLED: February 2008
SAMPLED BY: E TTL Drill Crew
LOCATION: B-6, 18'-20'
SAMPLE No. :
DESCRIPTION: Tan Ash
TECHNICIAN: H. Walka
DATE: 03/14/08

RESULTS

Grain Diameter	% Retain	% Passing
+2.0 mm	10.97	
+0.05 mm	18.74	
0.05 to 2.0 mm		7.77
0.002 to 0.05 mm		77.39
> 0.002 mm		3.87

WEIGHT OF SAMPLE (AIR DRY)	50.00
WEIGHT OF SAMPLE (OVEN DRY)	49.81
PERCENT RETAINED ON # 10	10.97
SPECIFIC GRAVITY	2.732

	SIEVE	WEIGHT	%RETAIN	GRAIN DIA	%PASSING
Mc Hydrom	40	0.26	11.44	0.425	88.56
Tare Wt	29.86	60	0.42	0.250	88.28
Wet Wt.	51.33	100	0.78	0.150	87.64
Dry Wt	51.25	140	1.61	0.105	86.15
MC	0.3740%	200	2.62	0.075	84.35

TEMP (C)	HYDROMETER CORRECTION	HYDROMETER READING	CORRECTED READING	L.Hydrom FACTOR	K. Diam. FACTOR	a. SP.GR. FACTOR	TIME (MIN)	GRAIN DIA (MM)	% SOIL PASSING
22.0	5.6	52.0	46.4	8.8	0.0140	0.99	0.5	0.0586	82.16
22.0	5.6	51.0	45.4	8.9	0.0140	0.99	1	0.0417	80.39
22.0	5.6	48.5	42.9	9.4	0.0140	0.99	2	0.0303	75.97
22.0	5.6	47.0	41.4	9.6	0.0140	0.99	5	0.0194	73.31
22.0	5.6	35.0	29.4	11.5	0.0140	0.99	15	0.0122	52.08
22.0	5.6	13.0	7.4	15.2	0.0140	0.99	30	0.0099	13.15
22.0	5.6	9.5	3.9	15.8	0.0140	0.99	60	0.0072	6.96
22.0	5.6	8.5	2.9	16	0.0140	0.99	250	0.0035	5.19
22.0	5.6	7.5	1.9	16.1	0.0140	0.99	1440	0.0015	3.42

SPECIFIC GRAVITY	BOTTLE #	Bottle Wt	Bott & Water	WaterTemp	Corr. Soil	Bott, S & Water	WaterTemp	Specif. Grav	
Air dry Sample(gr)	50	3	179.93	678.11	22.5	49.81	709.70	22.5	2.732

Sieve % Pass	Sieve Size	Grams Retain	% Pass
	1-1/2"	0.00	100.00
Air Dry Start Wt.:	1"	28.83	89.03
262.8	3/4"	28.83	89.03
Dry Start Wt.:	3/8"	28.83	89.03
261.82	No 4	28.83	89.03
	No 10	28.83	89.03

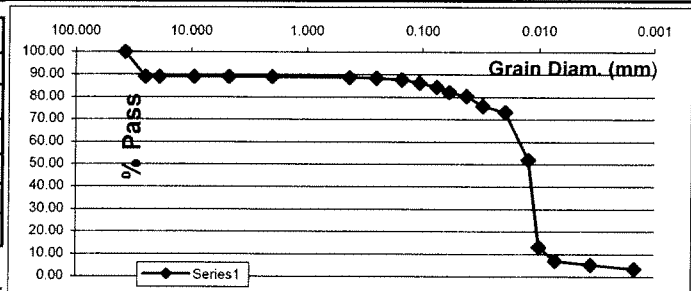

Remarks:

HYDROMETER AND MECHANICAL ANALYSIS OF SOIL BINDER, ASTM D422

PROJECT: Luminant Martin Lake, PDP 1-3
CLIENT: TXU
CONTRACTOR: not given
JOB No. : G 2810 - 08

REPORT No.:

DATE SAMPLED: February 2008
SAMPLED BY: E TTL Drill Crew
LOCATION: B-3, 5'-7'
SAMPLE No. :
DESCRIPTION: Black Ash
TECHNICIAN: H. Walka
DATE: 03/06/08

RESULTS

		Grain Diameter
% Retain	+2.0 mm	11.60
% Retain	+0.05 mm	76.50
% Passing	0.05 to 2.0 mm	64.91
% Passing	0.002 to 0.05 mm	21.88
% Passing	> 0.002 mm	1.62

WEIGHT OF SAMPLE (AIR DRY)	50.00
WEIGHT OF SAMPLE (OVEN DRY)	49.53
PERCENT RETAINED ON # 10	11.60
SPECIFIC GRAVITY	2.561

	SIEVE	WEIGHT	%RETAIN	GRAIN DIA	%PASSING
Mc Hydrom	40	7.81	25.54	0.425	74.46
Tare Wt	29.43	60	11.21	0.250	68.39
Wet Wt.	65.41	100	17.82	0.150	56.59
Dry Wt	65.07	140	22.64	0.105	47.99
MC	0.9540%	200	26.25	0.075	41.55

TEMP (C)	HYDROMETER CORRECTION	HYDROMETER READING	CORRECTED READING	L.Hydrom FACTOR	K. Diam. FACTOR	a. SP.GR. FACTOR	TIME (MIN)	GRAIN DIA (MM)	% SOIL PASSING
20.0	6.2	24.5	18.3	13.3	0.0143	1.02	0.5	0.0738	33.31
20.0	6.2	20.0	13.8	14.2	0.0143	1.02	1	0.0539	25.11
20.0	6.2	16.5	10.3	14.7	0.0143	1.02	2	0.0388	18.74
20.0	6.2	14.5	8.3	15	0.0143	1.02	5	0.0248	15.10
20.0	6.2	12.0	5.8	15.5	0.0143	1.02	15	0.0145	10.55
19.5	6.4	11.0	4.6	15.6	0.0145	1.02	30	0.0104	8.44
19.5	6.4	10.0	3.6	15.8	0.0145	1.02	60	0.0074	6.62
20.0	6.2	8.0	1.8	16.1	0.0143	1.02	250	0.0036	3.27
19.5	6.4	7.0	0.6	16.3	0.0145	1.02	1440	0.0015	1.15

SPECIFIC GRAVITY	BOTTLE #	Bottle Wt	Bott & Water	WaterTemp	Corr. Soil	Bott, S & Water	WaterTemp	Specif. Grav	
Air dry Sample(gr)	100	7	179.97	678.12	22.5	99.06	738.67	21.0	2.561

	Sieve Size	Grams Retain	% Pass
Sieve % Pass	1-1/2"	0.00	100.00
Air Dry Start Wt.:	1"	0.00	100.00
335.3	3/4"	0.00	100.00
Dry Start Wt.:	3/8"	3.42	98.98
332.13	No 4	17.17	94.88
	No 10	38.89	88.40

Remarks:

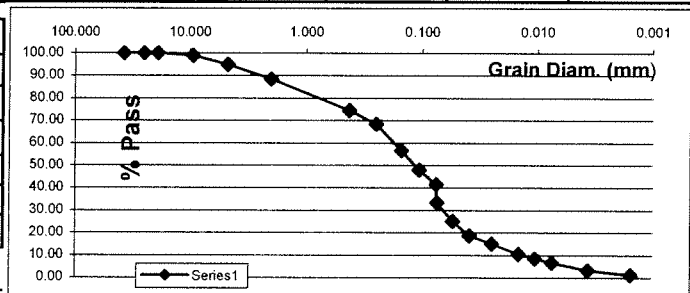

HYDROMETER AND MECHANICAL ANALYSIS OF SOIL BINDER, ASTM D422

PROJECT: Luminant Martin Lake, PDP 1-3
 CLIENT: TXU
 CONTRACTOR: not given
 JOB No. : G 2810 - 08

REPORT No.:

DATE SAMPLED: February 2008
SAMPLED BY: Ettl Drill Crew
LOCATION: B-2, 23'-25'
SAMPLE No. :
DESCRIPTION: Light Gray & Black Ash
TECHNICIAN: H. Walka
DATE: 03/06/08

RESULTS

	Grain Diameter	
% Retain	+2.0 mm	0.76
% Retain	+0.05 mm	16.00
% Passing	0.05 to 2.0 mm	15.24
% Passing	0.002 to 0.05 mm	83.90
% Passing	> 0.002 mm	0.09

WEIGHT OF SAMPLE (AIR DRY)	50.00
WEIGHT OF SAMPLE (OVEN DRY)	49.16
PERCENT RETAINED ON # 10	0.76
SPECIFIC GRAVITY	2.675

	SIEVE	WEIGHT	%RETAIN	GRAIN DIA	%PASSING
Mc Hydrom	40	0.89	2.56	0.425	97.44
Tare Wt	29.91	60	1.22	0.250	96.78
Wet Wt.	55.02	100	2.01	0.150	95.18
Dry Wt	54.60	140	2.67	0.105	93.85
MC	1.7011%	200	3.07	0.075	93.04

TEMP (C)	HYDROMETER CORRECTION	HYDROMETER READING	CORRECTED READING	L.Hydrom FACTOR	K. Diam. FACTOR	a. SP.GR. FACTOR	TIME (MIN)	GRAIN DIA (MM)	% SOIL PASSING
20.0	6.2	48.5	42.3	9.4	0.0143	1.00	0.5	0.0620	85.37
20.0	6.2	47.5	41.3	9.6	0.0143	1.00	1	0.0443	83.35
20.0	6.2	46.5	40.3	9.7	0.0143	1.00	2	0.0315	81.33
20.0	6.2	44.5	38.3	10.1	0.0143	1.00	5	0.0203	77.30
20.0	6.2	35.0	28.8	11.7	0.0143	1.00	15	0.0126	58.12
20.0	6.2	19.0	12.8	14.3	0.0143	1.00	30	0.0099	25.83
20.0	6.2	6.5	0.3	16.3	0.0143	1.00	60	0.0075	0.59
20.0	6.2	6.3	0.1	16.3	0.0143	1.00	250	0.0037	0.19
19.5	6.4	6.4	0.0	16.3	0.0145	1.00	1440	0.0015	0.07

SPECIFIC GRAVITY	BOTTLE #	Bottle Wt	Bott & Water	WaterTemp	Corr. Soil	Bott, S & Water	WaterTemp	Specif. Grav	
Air dry Sample(gr)	50	4	179.25	677.26	22.5	49.16	708.22	21.0	2.675

	Sieve Size	Grams Retain	% Pass
Sieve % Pass	1-1/2"	0.00	100.00
Air Dry Start Wt.:	1"	0.00	100.00
144.3	3/4"	0.00	100.00
Dry Start Wt.:	3/8"	0.00	100.00
141.89	No 4	0.10	99.93
	No 10	1.10	99.24

Remarks:

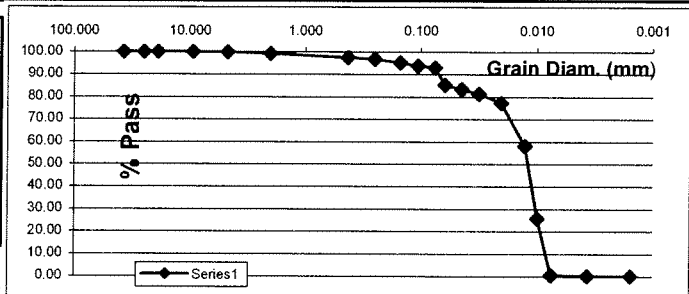

HYDROMETER AND MECHANICAL ANALYSIS OF SOIL BINDER, ASTM D422

PROJECT: Luminant Martin Lake, PDP 1-3
 CLIENT: TXU
 CONTRACTOR: not given
 JOB No. : G 2810 - 08

REPORT No.:

DATE SAMPLED: February 2008
SAMPLED BY: E TTL Drill Crew
LOCATION: B-1, 18'-20'
SAMPLE No. :
DESCRIPTION: Black, Tan & Gray Ash
TECHNICIAN: H. Walka
DATE: 03/06/08

RESULTS

		Grain Diameter
% Retain	+2.0 mm	14.96
% Retain	+0.05 mm	64.42
% Passing	0.05 to 2.0 mm	49.46
% Passing	0.002 to 0.05 mm	35.29
% Passing	> 0.002 mm	0.29

WEIGHT OF SAMPLE (AIR DRY)	50.00
WEIGHT OF SAMPLE (OVEN DRY)	49.29
PERCENT RETAINED ON # 10	14.96
SPECIFIC GRAVITY	2.608

	SIEVE	WEIGHT	%RETAIN	GRAIN DIA	%PASSING
Mc Hydrom	40	5.76	24.90	0.425	75.10
Tare Wt	29.29	60	8.38	0.250	70.58
Wet Wt.	59.40	100	12.31	0.150	63.80
Dry Wt	58.97	140	15.78	0.105	57.81
MC	1.4488%	200	18.60	0.075	52.95

TEMP (C)	HYDROMETER CORRECTION	HYDROMETER READING	CORRECTED READING	L.Hydrom FACTOR	K. Diam. FACTOR	a. SP.GR. FACTOR	TIME (MIN)	GRAIN DIA (MM)	% SOIL PASSING
20.0	6.2	31.5	25.3	12.2	0.0143	1.01	0.5	0.0707	44.08
20.0	6.2	27.0	20.8	13	0.0143	1.01	1	0.0516	36.24
20.0	6.2	24.5	18.3	13.3	0.0143	1.01	2	0.0369	31.88
20.0	6.2	23.5	17.3	13.5	0.0143	1.01	5	0.0235	30.14
20.0	6.2	18.5	12.3	14.3	0.0143	1.01	15	0.0140	21.43
20.0	6.2	10.0	3.8	15.8	0.0143	1.01	30	0.0104	6.61
20.0	6.2	7.0	0.8	16.3	0.0143	1.01	60	0.0075	1.38
20.0	6.2	6.5	0.3	16.3	0.0143	1.01	250	0.0037	0.51
19.5	6.4	6.5	0.1	16.3	0.0145	1.01	1440	0.0015	0.23

SPECIFIC GRAVITY	BOTTLE #	Bottle Wt	Bott & Water	WaterTemp	Corr. Soil	Bott, S & Water	WaterTemp	Specif. Grav	
Air dry Sample(gr)	100	3	179.93	678.11	22.5	98.57	739.11	20.5	2.608

Sieve Size	Grams Retain	% Pass
1-1/2"	0.00	100.00
Air Dry Start Wt.:	1"	0.00
268.4	3/4"	15.10
Dry Start Wt.:	3/8"	15.10
264.57	No 4	25.58
	No 10	40.15

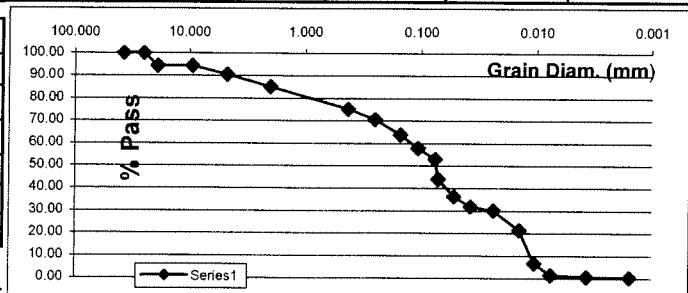

Remarks:

HYDROMETER AND MECHANICAL ANALYSIS OF SOIL BINDER, ASTM D422

PROJECT: Luminant Martin Lake, PDP 1-3
CLIENT: TXU
CONTRACTOR: not given
JOB No. : G 2810 - 08

REPORT No.:
DATE SAMPLED: February 2008
SAMPLED BY: E TTL Drill Crew
LOCATION: MLSES
SAMPLE No. :
DESCRIPTION: Tan & Gray Economizet Ash
TECHNICIAN: M. Thompson
DATE: 04/15/08

RESULTS

Grain Diameter	% Retain	% Passing
+2.0 mm	41.02	
+0.05 mm	95.89	
0.05 to 2.0 mm		54.87
0.002 to 0.05 mm		3.55
> 0.002 mm		0.55

WEIGHT OF SAMPLE (AIR DRY)	50.00
WEIGHT OF SAMPLE (OVEN DRY)	49.98
PERCENT RETAINED ON # 10	41.02
SPECIFIC GRAVITY	2.670

	SIEVE	WEIGHT	%RETAIN	GRAIN DIA	%PASSING
Mc Hydrom	40	13.34	56.76	0.425	43.24
Tare Wt	30.27	60	22.12	0.250	32.88
Wet Wt.	62.43	100	32.26	0.150	20.91
Dry Wt	62.42	140	38.01	0.105	14.13
MC	0.0311%	200	42.66	0.075	8.64

TEMP (C)	HYDROMETER CORRECTION	HYDROMETER READING	CORRECTED READING	L.Hydrom FACTOR	K. Diam. FACTOR	a. SP.GR. FACTOR	TIME (MIN)	GRAIN DIA (MM)	% SOIL PASSING
21.5	5.7	13.0	7.3	15.2	0.0141	1.00	0.5	0.0780	8.58
21.5	5.7	10.0	4.3	15.6	0.0141	1.00	1	0.0558	5.04
21.5	5.7	9.0	3.3	15.8	0.0141	1.00	2	0.0397	3.86
21.5	5.7	7.5	1.8	16.1	0.0141	1.00	5	0.0254	2.09
21.5	5.7	7.0	1.3	16.1	0.0141	1.00	15	0.0146	1.50
21.5	5.7	6.8	1.1	16.1	0.0141	1.00	30	0.0104	1.27
21.5	5.7	6.5	0.8	16.3	0.0141	1.00	60	0.0074	0.91
21.5	5.7	6.3	0.6	16.3	0.0141	1.00	250	0.0036	0.68
22.0	5.6	6.0	0.4	16.3	0.0140	1.00	1440	0.0015	0.51

SPECIFIC GRAVITY	BOTTLE #	Bottle Wt	Bott & Water	WaterTemp	Corr. Soil	Bott, S & Water	WaterTemp	Specif. Grav	
Air dry Sample(gr)	100	7	179.97	678.12	22.5	99.97	740.78	21.5	2.670

Sieve % Pass	Sieve Size	Grams Retain	% Pass
Air Dry Start Wt.:	1-1/2"	0.00	100.00
2182.9	1"	0.00	100.00
Dry Start Wt.:	3/4"	0.00	100.00
2182.22	3/8"	12.53	99.43
	No 4	200.01	90.83
	No 10	895.12	58.98

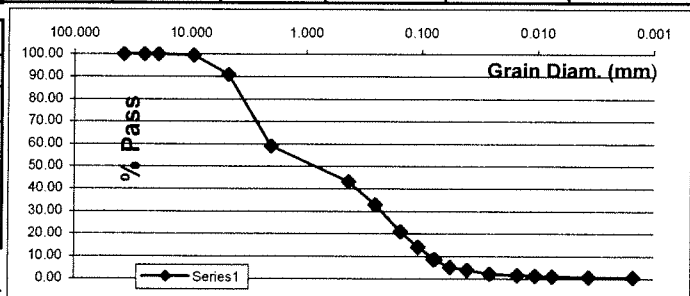

Remarks:

ASTM D 2850 Confined Compressive Strength of Cohesive Soil

Project: Luminant Martin Lake: PDP 1-3

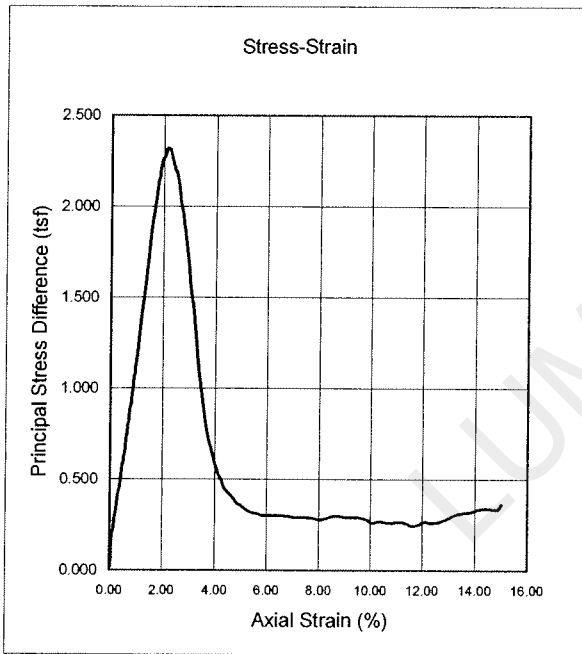

Project No.:	<u>G 2810-08</u>	
Boring No.:	<u>B-7</u>	
Depth, ft.:	<u>5'-7'</u>	
Material:	<u>Black Ash with Gravel</u>	
Initial Height	<u>5.706</u>	<u>Inches</u>
Initial Diameter	<u>2.767</u>	<u>Inches</u>
Moisture Content:	<u>22.9%</u>	<u>%</u>
Dry Density:	<u>97.5</u>	<u>lbs/cu ft</u>
Specific Gravity (Assumed)	<u>2.670</u>	
Volume of Solids:	<u>0.585</u>	
Volume of Voids	<u>0.415</u>	
Void Ratio:	<u>0.709</u>	
Confining Pressure:	<u>6.1</u>	<u>PSI</u>
Pocket Penetr. Reading:	<u>4.5</u>	
Torvane (T)	<u> </u>	
Rate of Strain: (%/ min)	<u>1.0%</u>	
Peak Strain:	<u>2.1</u>	<u>%</u>
Max Stress:	<u>2.32</u>	<u>TSF</u>
Date:	<u>3/11/2008</u>	

1/2 Stress (KSF) 2.321

Strain at 1/2 Stress (%) 0.99

Type of Specimen: Native

Remarks: _____

Secant Modulus (KSF) @ 1/2 Peak Stress 234

RQD Value: 100%

Angle of Fracture in Degrees: 65

Sketch of Fracture:



ASTM D 2850 Confined Compressive Strength of Cohesive Soil

Project: TXU PDP: Martin Lake, TX

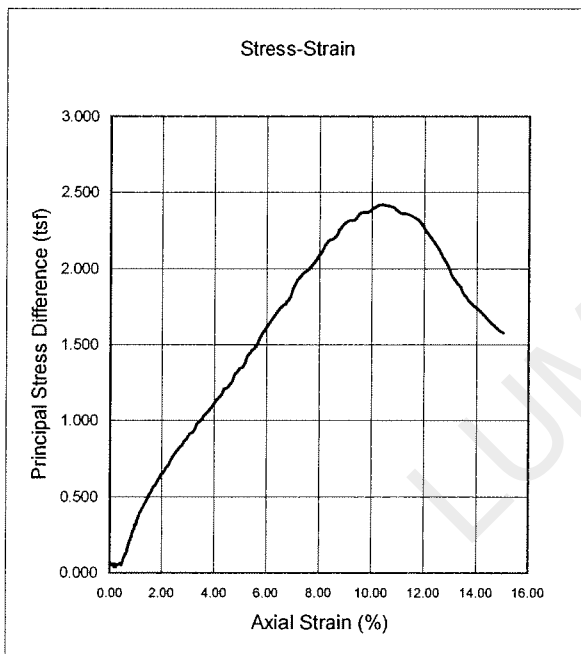

Project No.:	<u>G 2810-08</u>
Boring No.:	<u>B-4</u>
Depth, ft.:	<u>13'-15'</u>
Material:	<u>Red & Gray Laminated Lean Clay</u>
Initial Height	<u>3.613</u> Inches
Initial Diameter	<u>2.667</u> Inches
Moisture Content:	<u>22.3%</u> %
Dry Density:	<u>99.4</u> lbs/cu ft
Specific Gravity (Assumed)	<u>2.670</u>
Volume of Solids:	<u>0.596</u>
Volume of Voids	<u>0.404</u>
Void Ratio:	<u>0.677</u>
Confining Pressure:	<u>13</u> PSI
Pocket Penetr. Reading:	<u>3.5</u>
Torvane (T)	<u></u>
Rate of Strain: (%/ min)	<u>1.0%</u>
Peak Strain:	<u>10.3</u> %
Max Stress:	<u>2.42</u> TSF
Date:	<u>5/12/2008</u>

1/2 Stress (KSF) 2.416

Strain at 1/2 Stress (%) 3.94

Type of Specimen: Native

Remarks: undefined fracture

Secant Modulus (KSF) @ 1/2 Peak Stress 61

RQD Value: 100%

Angle of Fracture in Degrees: N/A

Sketch of Fracture:

ASTM D 2850 Confined Compressive Strength of Cohesive Soil

Project: Luminant Martin Lake: PDP 1-3

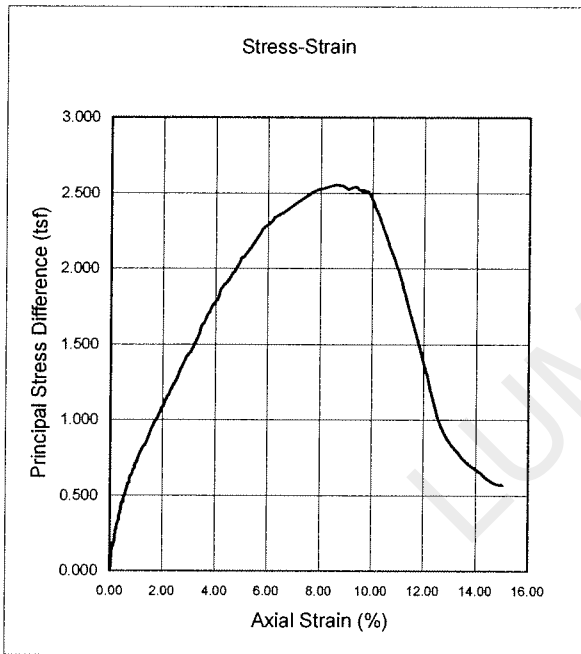

Project No.: G 2810-08
 Boring No.: B-4
 Depth, ft.: 13'-15'
 Material: Light Gray & Red Silty Clayey Sand w/ Ferric seams
 Initial Height 5.688 Inches
 Initial Diameter 2.75 Inches
Moisture Content: 21.5% %
 Dry Density: 104.6 lbs/cu ft
 Specific Gravity (Assumed) 2.670
 Volume of Solids: 0.628
 Volume of Voids 0.372
 Void Ratio: 0.593
 Confining Pressure: 13 PSI
 Pocket Penetr. Reading: 3.9
 Torvane (T) 1.138
 Rate of Strain: (%/ min) 1.0%
Peak Strain: 8.6 %
Max Stress: 2.55 TSF
 Date: 4/11/2008

1/2 Stress (KSF) 2.552

Strain at 1/2 Stress (%) 2.54

Type of Specimen: Native

Remarks: _____

Secant Modulus (KSF) @ 1/2 Peak Stress 100

RQD Value: 100%

Angle of Break in Degrees: 60

Sketch of Fracture:



ASTM D 2850 Confined Compressive Strength of Cohesive Soil

Project: Luminant Martin Lake: PDP 1-3

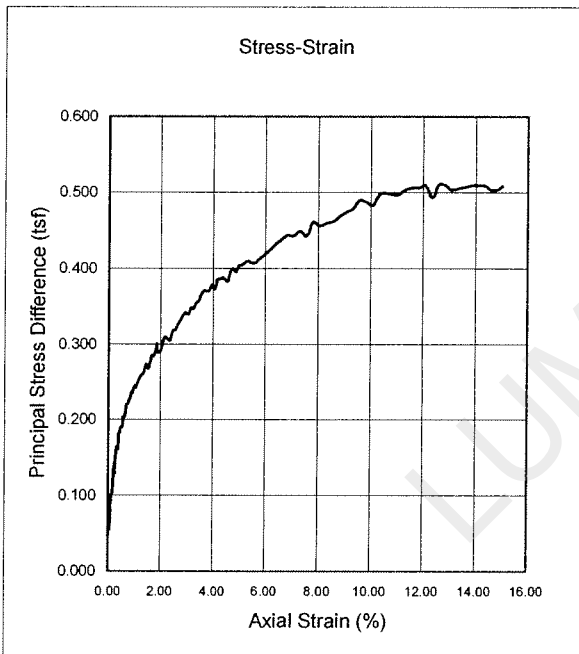

Project No.:	<u>G 2810-08</u>
Boring No.:	<u>B-7</u>
Depth, ft.:	<u>23'-25'</u>
Material:	<u>Black, Red, Tan, & Gray Clay w/ gravel</u>
Initial Height	<u>5.686</u> Inches
Initial Diameter	<u>2.717</u> Inches
Moisture Content:	<u>21.0%</u> %
Dry Density:	<u>103.9</u> lbs/cu ft
Specific Gravity (Assumed)	<u>2.670</u>
Volume of Solids:	<u>0.624</u>
Volume of Voids	<u>0.376</u>
Void Ratio:	<u>0.603</u>
Confining Pressure:	<u>21.7</u> PSI
Pocket Penetr. Reading:	<u> </u>
Torvane (T)	<u> </u>
Rate of Strain: (%/ min)	<u>1.0%</u>
Peak Strain:	<u>12.8</u> %
Max Stress:	<u>0.51</u> TSF
Date:	<u>3/11/2008</u>

1/2 Stress (KSF) 0.510

Strain at 1/2 Stress (%) 1.20

Type of Specimen: Native

Remarks: Not able to find a well defined fracture

Secant Modulus (KSF) @ 1/2 Peak Stress 43

RQD Value: 100%

Angle of Break in Degrees: 53

Sketch of Fracture:

CONSOLIDATION TEST REPORT

ASTM D 2435

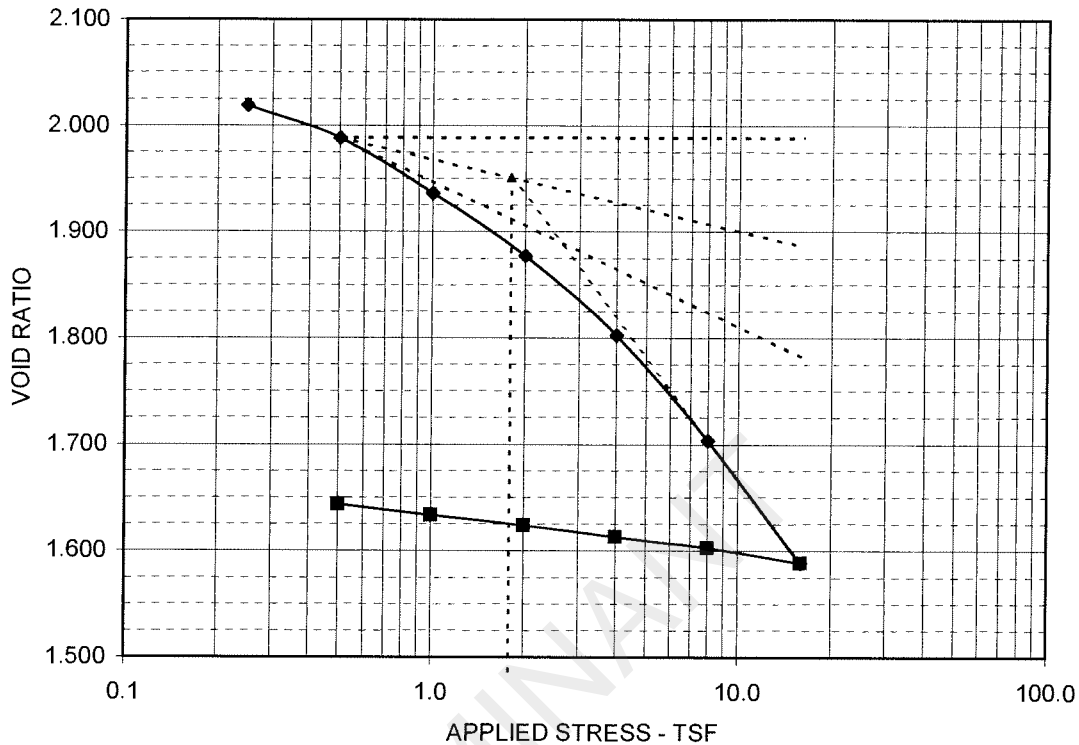

$C_c = 0.381$ $C_r = 0.033$ $e_0 = 2.0191$ P_c (tsf) = 1.79 OCR = 10.2

LOAD tsf	c_v in ² /min	k in/min
Seating	NA	NA
0.50	9.34E-03	9.85E-07
1.00	5.36E-03	4.89E-07
2.00	5.03E-03	2.65E-07
4.00	5.04E-03	1.73E-07
8.00	5.03E-03	1.18E-07
16.00	5.03E-03	7.08E-08

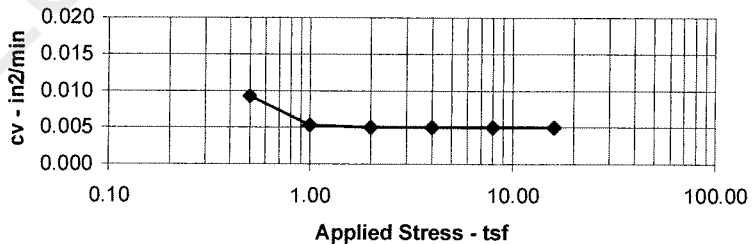

c_v values calculated by Sivaram and Swamee's Method

SAMPLE AND TEST DATA				PROJECT INFORMATION	
SAMPLE LOCATION: B-6, 3-5'				PROJECT: Luminant Martin Lake PDP 1-3	
DESCRIPTION: Ash, black and dark gray				LOCATION: Rusk, TX.	
LL: NA	PL: NA	PI: NA	-200:NA	PROJECT NO.:	ETT08002-07
ASSUMED SPECIFIC GRAVITY: 2.70				CLIENT:	ETTL Engineers & Consultants, Inc.
MC Initial: 58.1%	MC Final: 47.2%			CLIENT NO.:	G2810-08
Dia. (in.): 2.50	Height (in.): 1.000			DATE:	4/24/2008
Initial Sat %: 70.2	Final Sat %: 100.0			REMARKS: OCR calculated based on P_c and vertical overburden	
DRY DENSITY (pcf): 55.8				GREGORY GEOTECHNICAL	
				PLATE B-CN.1	

CONSOLIDATION TEST REPORT

ASTM D 2435

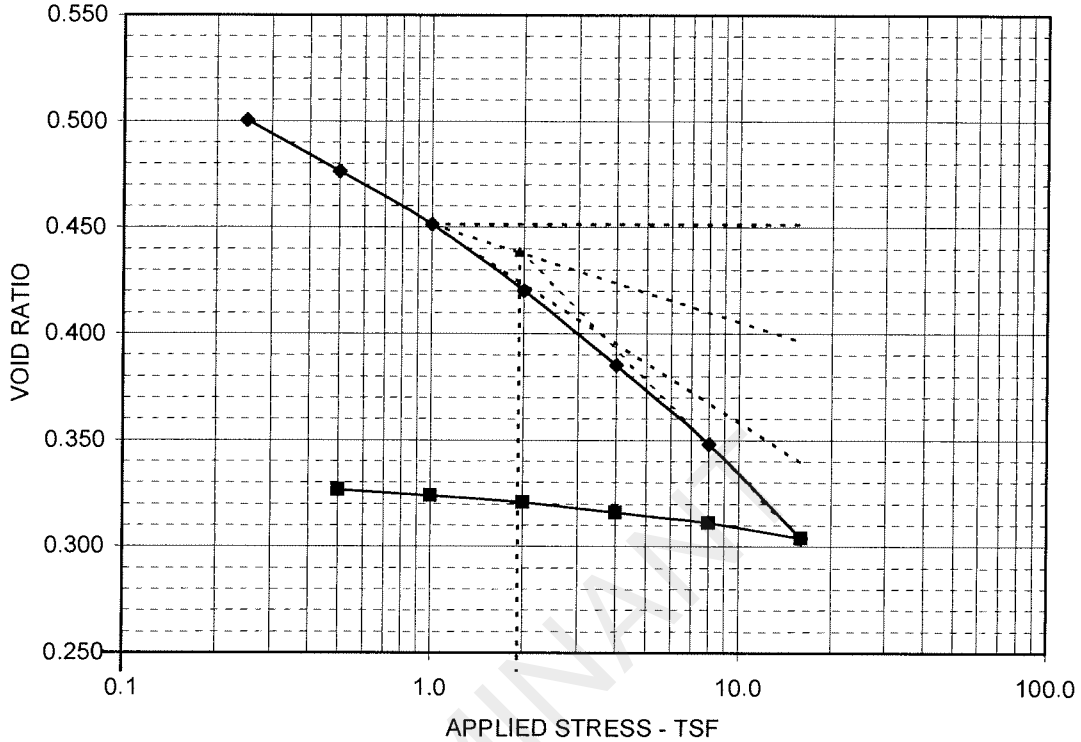

$C_c = 0.146$	$C_r = 0.012$	$e_0 = 0.5597$	P_c (tsf) = 1.93	OCR = 3.5
---------------	---------------	----------------	--------------------	-----------

LOAD tsf	c_v in ² /min	k in/min
Seating	NA	NA
0.50	1.67E-02	2.82E-06
1.00	1.51E-02	1.33E-06
2.00	1.55E-02	8.75E-07
4.00	1.54E-02	5.00E-07
8.00	1.51E-02	2.67E-07
16.00	1.39E-02	1.50E-07

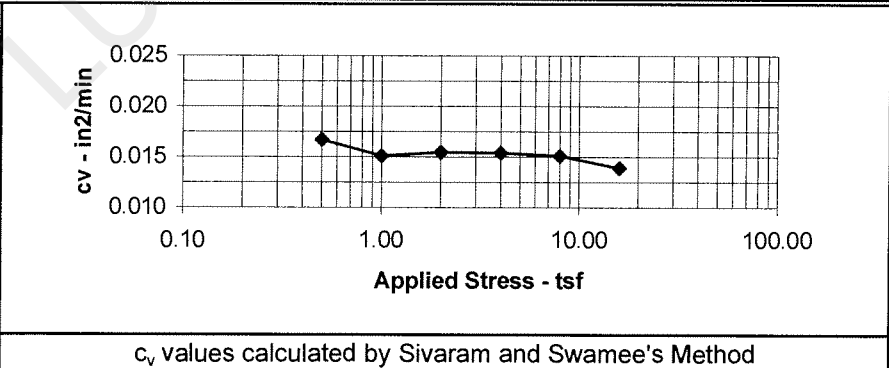

c_v values calculated by Sivaram and Swamee's Method

SAMPLE AND TEST DATA	PROJECT INFORMATION
SAMPLE LOCATION: B-4, 8-10' DESCRIPTION: Clayey Sand , reddish brown with gray LL: NA PL: NA PI: NA -200: NA ASSUMED SPECIFIC GRAVITY: 2.70 MC Initial: 13.0% MC Final: 19.6% Dia. (in.): 2.50 Height (in.): 1.000 Initial Sat %: 70.2 Final Sat %: 100.0 DRY DENSITY (pcf): 108.0	PROJECT: Luminant Martin Lake PDP 1-3 LOCATION: Rusk, TX. PROJECT NO.: ETT08002-07 CLIENT: E TTL Engineers & Consultants, Inc. CLIENT NO.: G2810-08 DATE: 4/24/2008 REMARKS: OCR calculated based on Pc and vertical overburden
GREGORY GEOTECHNICAL	PLATE B-CN.2

$y = 0.8336x + 0.45$
 $R^2 = 0.9982$

DIRECT SHEAR TEST REPORT

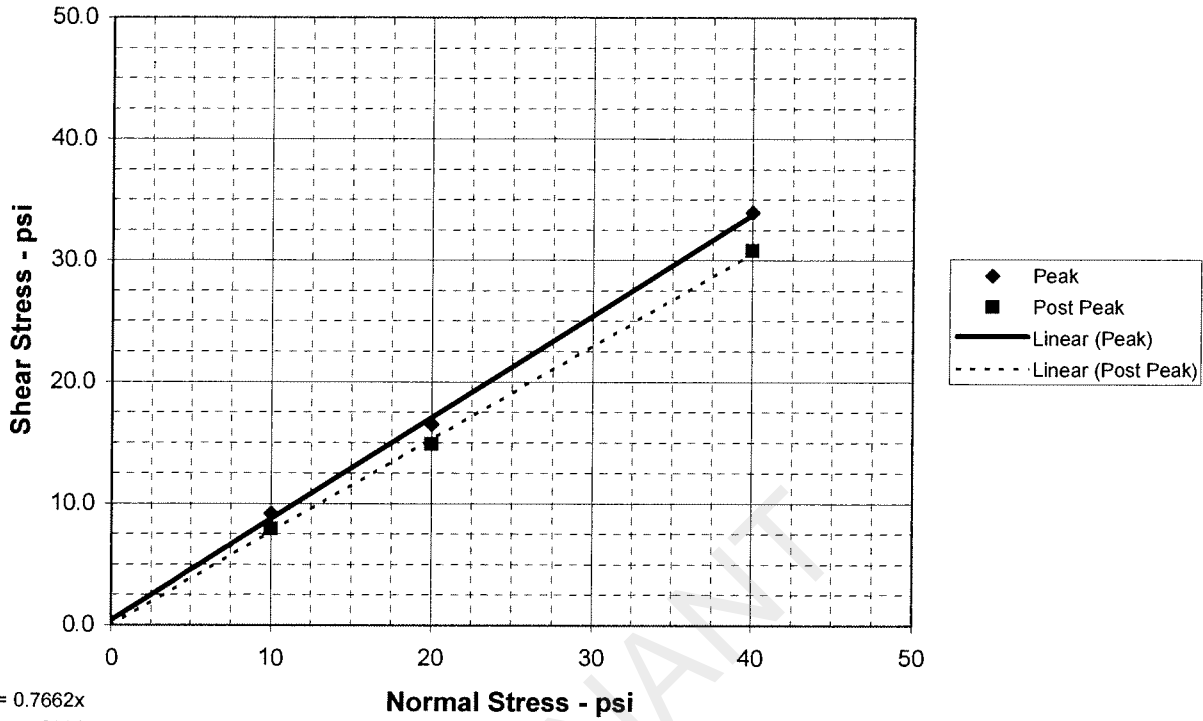

PEAK STRENGTH PARAMETERS	$\phi = 39.8 \text{ deg}$	$c = 0.5 \text{ psi}$
POST PEAK STRENGTH PARAMETERS	$\phi = 37.5 \text{ deg}$	$c = 0.0 \text{ psi}$

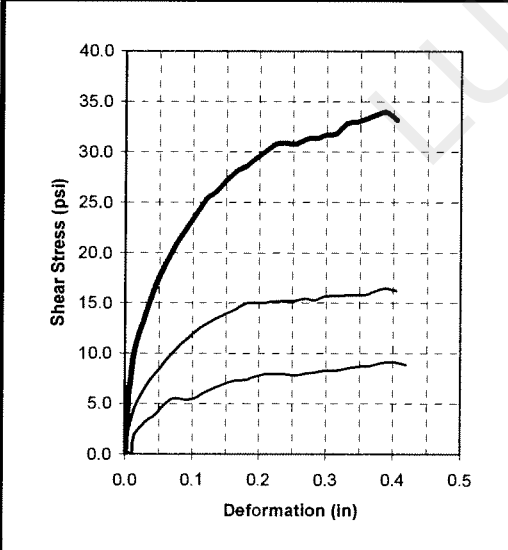

	SPECIMEN NO.			
	1	2	3	4
INITIAL				
Moisture Content - %	52.1	29.3	21.2	
Dry Density - pcf	50.2	71.7	95.2	
Diameter - inches	2.50	2.50	2.50	
Height - inches	1.13	1.13	1.13	
AT TEST				
Final Moisture - %	64.3	25.0	31.6	
Dry Density - pcf	55.8	79.1	117.3	
Height-End of Consol. (in.)	1.02	1.03	0.92	
Height-End of Shear (in.)	0.97	0.99	0.89	
Normal Stress - psi	10.0	20.0	40.0	
Peak Failure Stress-psi	9.2	16.5	34.0	
Post Peak Failure Stress-psi	7.9	14.9	30.8	
Strain Rate - inches/min.	0.00300	0.00300	0.00300	
Peak Failure Strain - %	16.2	15.6	15.6	
Post Peak Failure Strain %	8.4	7.2	9.6	

TEST DESCRIPTION	PROJECT INFORMATION
TYPE OF TEST & NO: CD-DS-1 SAMPLE TYPE: Shelby Tube DESCRIPTION: Ash, black and gray SAMPLE LOCATION: B-6, 3-5 ft ASSUMED SPECIFIC GRAVITY: 2.65 LL: 35 PL: 19 PI: 16 Percent -200: 61 REMARKS: Multi-Specimen	PROJECT: Luminant Martin Lake PDP 1-3 LOCATION: Rusk , TX PROJECT NO: ETT08002-07 (G2810-08) CLIENT : E TTL Engineers & Consultants, Inc DATE: 4/25/08 <div style="display: flex; justify-content: space-between;"> GREGORY GEOTECHNICAL PLATE: B-DS.1 </div>

$y = 0.8829x + 2.2$
 $R^2 = 0.9987$

DIRECT SHEAR TEST REPORT

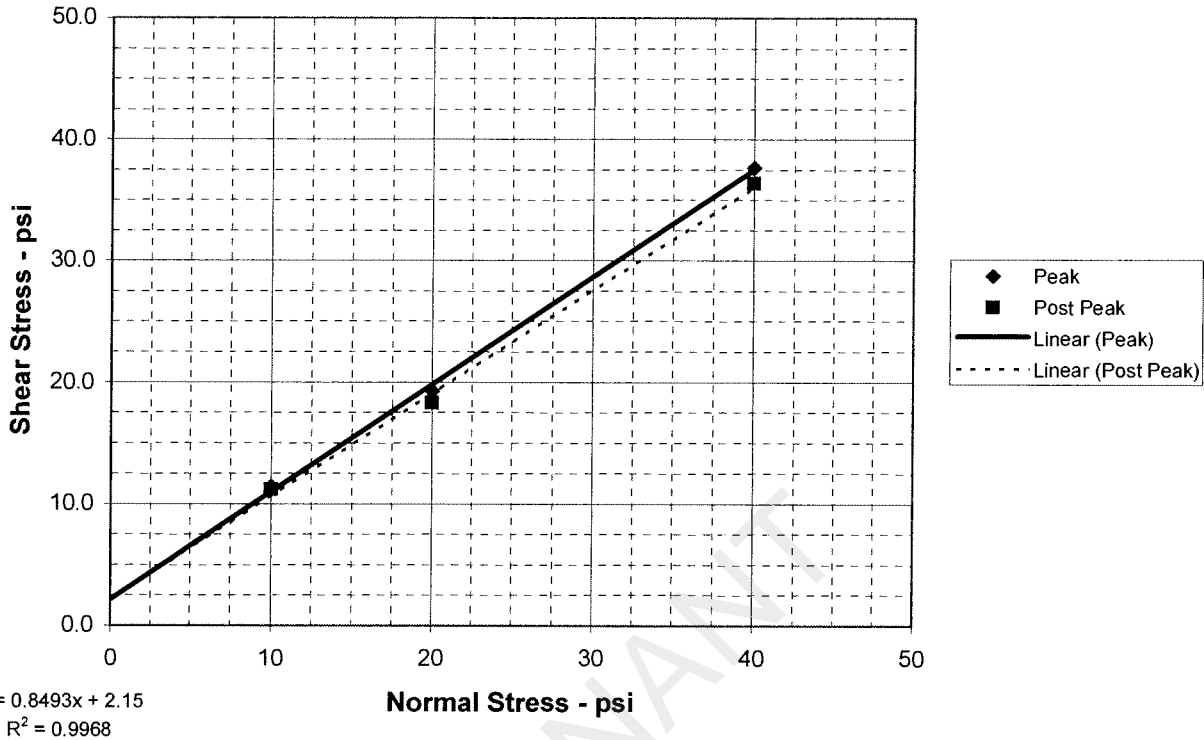

PEAK STRENGTH PARAMETERS	$\phi = 41.4$ deg	$c = 2.2$ psi
POST PEAK STRENGTH PARAMETERS	$\phi = 40.3$ deg	$c = 2.2$ psi

	SPECIMEN NO.	1	2	3	4	
	INITIAL					
	Moisture Content - %	13.1	13.1	13.1		
	Dry Density - pcf	71.8	71.7	71.7		
	Diameter - inches	2.50	2.50	2.50		
	Height - inches	1.00	1.00	1.00		
	AT TEST					
	Final Moisture - %	38.5	37.4	31.6		
	Dry Density - pcf	73.6	73.7	75.8		
	Height-End of Consol. (in.)	0.98	0.97	0.95		
Height-End of Shear (in.)	1.00	0.96	0.92			
Normal Stress - psi	10.0	20.0	40.0			
Peak Failure Stress-psi	11.4	19.3	37.7			
Post Peak Failure Stress-psi	11.2	18.3	36.4			
Strain Rate - inches/min.	0.00300	0.00300	0.00300			
Peak Failure Strain - %	15.6	15.6	13.2			
Post Peak Failure Strain %	13.8	12.0	15.0			
Dry Density at test based on initial moisture and height at end of consolidation.						

TEST DESCRIPTION	PROJECT INFORMATION
TYPE OF TEST & NO: CD-DS-2 SAMPLE TYPE: Re-Compacted DESCRIPTION: Ash, black and dark gray SAMPLE LOCATION: MLSES (Bulk) SPECIFIC GRAVITY: 2.56 LL: NP PL: NP PI: NP Percent -200: 3.33 REMARKS: Multi-Specimen	PROJECT: Luminant Martin Lake PDP 1-3 LOCATION: Rusk , TX PROJECT NO: ETT08002-07 (G2810-08) CLIENT : Ettl Engineers & Consultants, Inc DATE:5/6/08 <div style="display: flex; justify-content: space-between; font-weight: bold; font-size: medium;"> GREGORY GEOTECHNICAL PLATE: B-DS.2 </div>

$y = 0.9043x + 5.7$
 $R^2 = 0.9961$

DIRECT SHEAR TEST REPORT

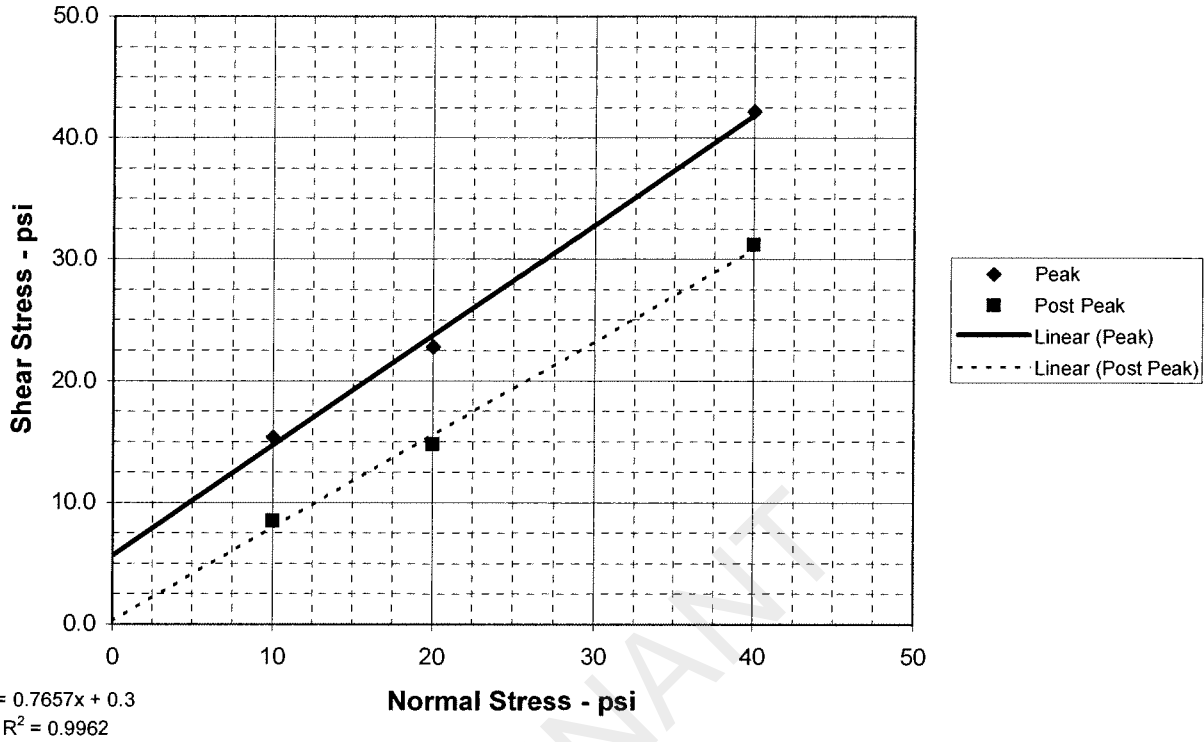

PEAK STRENGTH PARAMETERS	$\phi = 42.1 \text{ deg}$	$c = 5.7 \text{ psi}$
POST PEAK STRENGTH PARAMETERS	$\phi = 37.4 \text{ deg}$	$c = 0.3 \text{ psi}$

	SPECIMEN NO.	1	2	3	4	
	INITIAL					
	Moisture Content - %	0.1	0.1	0.1		
	Dry Density - pcf	71.7	71.7	71.7		
	Diameter - inches	2.50	2.50	2.50		
	Height - inches	1.00	1.00	1.00		
	AT TEST					
	Final Moisture - %	50.3	37.4	31.6		
	Dry Density - pcf	73.4	73.1	73.1		
	Height-End of Consol. (in.)	0.98	0.98	0.98		
Height-End of Shear (in.)	1.01	1.01	0.99			
Normal Stress - psi	10.0	20.0	40.0			
Peak Failure Stress-psi	15.4	22.8	42.2			
Post Peak Failure Stress-psi	8.5	14.8	31.2			
Strain Rate - inches/min.	0.00300	0.00300	0.00300			
Peak Failure Strain - %	17.6	3.0	3.6			
Post Peak Failure Strain %	15.0	15.6	13.8			
Dry Density at test based on initial moisture and height at end of consolidation.						

TEST DESCRIPTION	PROJECT INFORMATION
TYPE OF TEST & NO: CD-DS-2 SAMPLE TYPE: Re-Compacted DESCRIPTION: Economized Ash, tan and gray SAMPLE LOCATION: MLSES (Bulk) SPECIFIC GRAVITY: 2.67 LL: NP PL: NP PI: NP Percent -200: 8.64 REMARKS: Multi-Specimen	PROJECT: Luminant Martin Lake PDP 1-3 LOCATION: Rusk , TX PROJECT NO: ETT08002-07 (G2810-08) CLIENT : E TTL Engineers & Consultants, Inc DATE: 5/20/08 <div style="display: flex; justify-content: space-between; margin-top: 10px;"> GREGORY GEOTECHNICAL PLATE: B-DS.3 </div>

PROJECT INFORMATION

PROJECT: Martin Lake PDP 1 - 3 Supplemental
LOCATION:
PROJECT NO: G 3219 - 09
CLIENT: HDR
September 2009

TRIAxIAL TEST PROGRAM BY GARRY H. GREGORY, P.E.

ALL RIGHTS RESERVED - UNAUTHORIZED USE PROHIBITED
VERSION 1.0 - AUGUST 1998 - REVISED MARCH 24, 1999

THIS COPY LICENSED TO:
ETTL ENGINEERS AND CONSULTANTS, INC.
1717 East Erwin
Tyler, TX 75702

TEST DESCRIPTION

TYPE OF TEST & NO: CU with PP
SAMPLE TYPE: Native Shelby Tube Sample
DESCRIPTION: Tan w/ Red & Gray Clayey Sand
Sampled on Site, B-16 8' to 10' deep
ASSUMED SPECIFIC GRAVITY: 2.7 + 40 Sieve
LL: PL: Pt: Percent -200:
REMARKS: Diameter and Both Ends Trimmed + # 4 Sieve

PLATE: B.1

PLATE: B.2

PLATE: B.3

Number of Specimens = 3

LUMINANT

TRIAXIAL SHEAR TEST REPORT

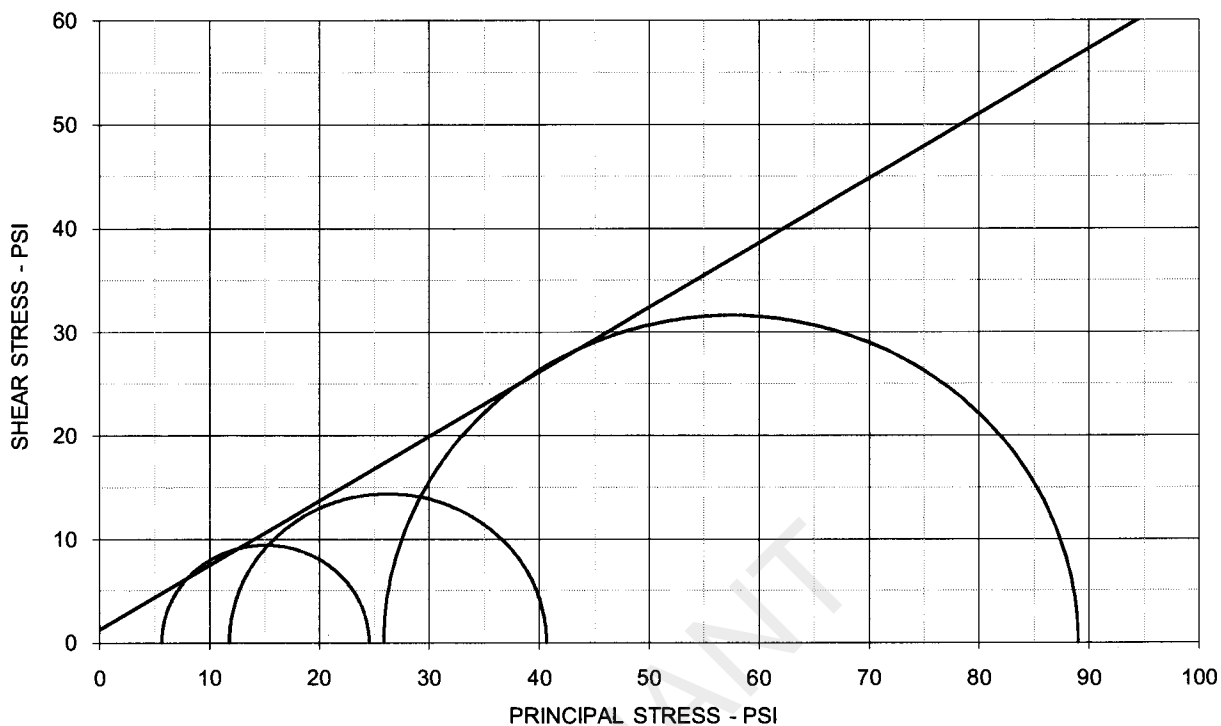

EFFECTIVE STRESS PARAMETERS

$\phi' = 31.9 \text{ deg}$ $c' = 1.3 \text{ psi}$

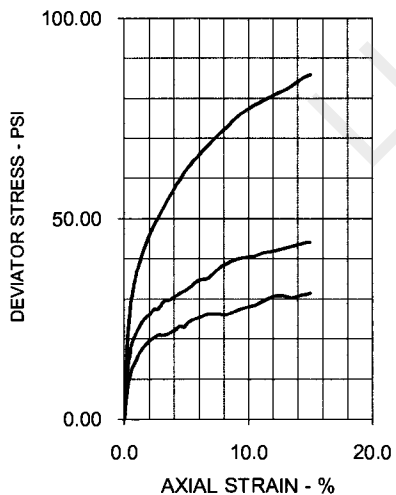

SPECIMEN NO.	1	2	3	4
INITIAL				
Moisture Content - %	17.2	16.8	16.3	
Dry Density - pcf	112.6	114.4	115.0	
Diameter - inches	2.47	2.46	2.48	
Height - inches	4.98	4.97	5.00	
AT TEST				
Final Moisture - %	18.4	16.5	16.0	
Dry Density - pcf	113.1	115.3	116.9	
Calculated Diameter (in.)	2.47	2.46	2.50	
Height - inches	5.00	4.97	5.06	
Effect. Cell Pressure - psi	10.0	20.0	40.0	
Failure Stress - psi	18.88	28.83	63.14	
Total Pore Pressure - psi	54.3	58.2	64.1	
Strain Rate - inches/min.	0.00050	0.00050	0.00050	
Failure Strain - %	1.8	3.0	5.2	
σ_1' Failure - psi	24.54	40.64	89.01	
σ_3' Failure - psi	5.66	11.81	25.87	

TEST DESCRIPTION

TYPE OF TEST & NO: CU with PP
 SAMPLE TYPE: Native Shelby Tube Sample
 DESCRIPTION: Tan w/ Red & Gray Clayey Sand
 Sampled on Site, B-16 8' to 10' deep
 ASSUMED SPECIFIC GRAVITY: 2.7 + 40 Sieve
 LL: PL: PI: Percent -200:
 REMARKS: Diameter and Both Ends Trimmed + # 4 Sieve
 G 3219-09, B-16-0-16 Native

PROJECT INFORMATION

PROJECT: Martin Lake PDP 1 - 3 Supplemental
 LOCATION:
 PROJECT NO: G 3219 - 09
 CLIENT: HDR
 September 2009

ETTL ENGINEERS & CONSULTANTS

PLATE: B.1

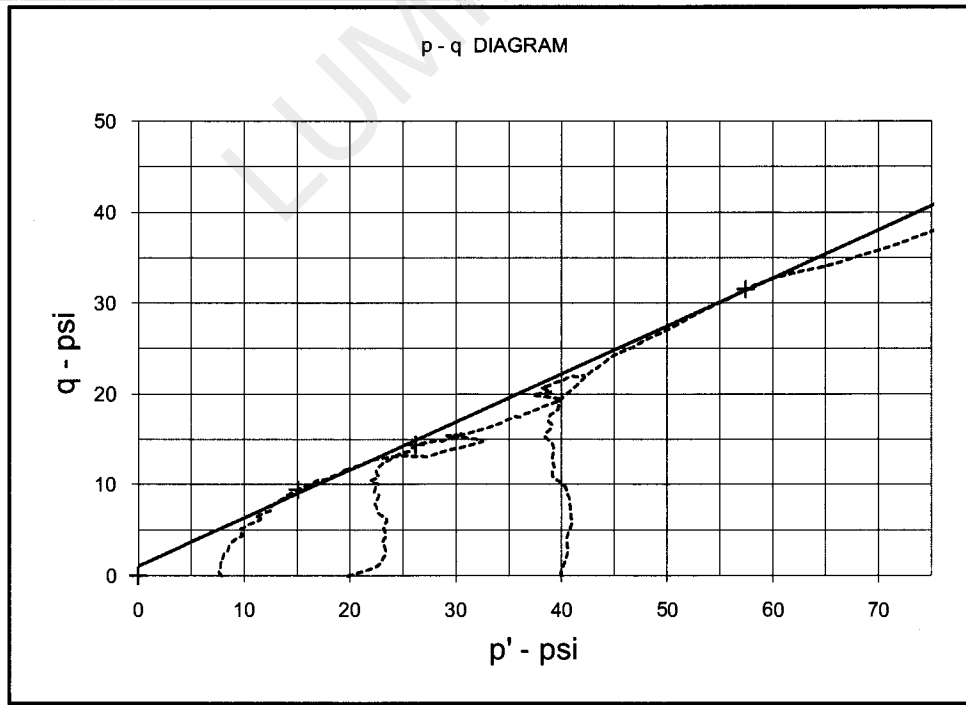
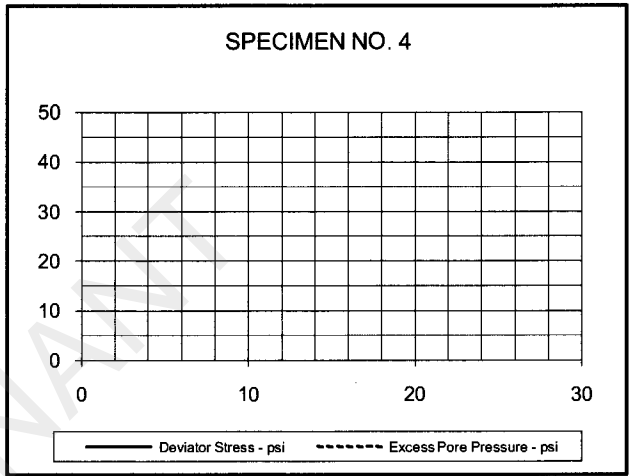
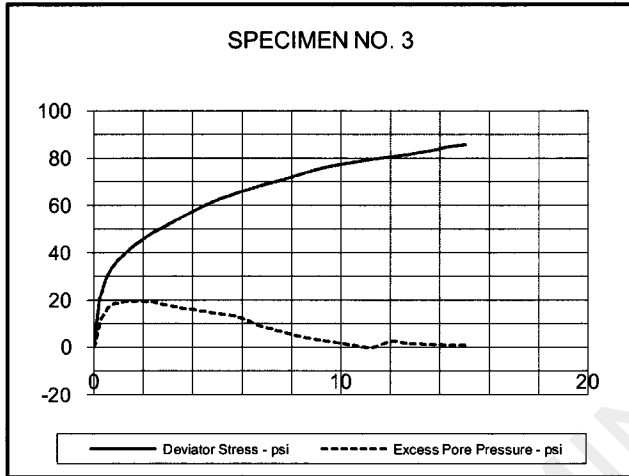
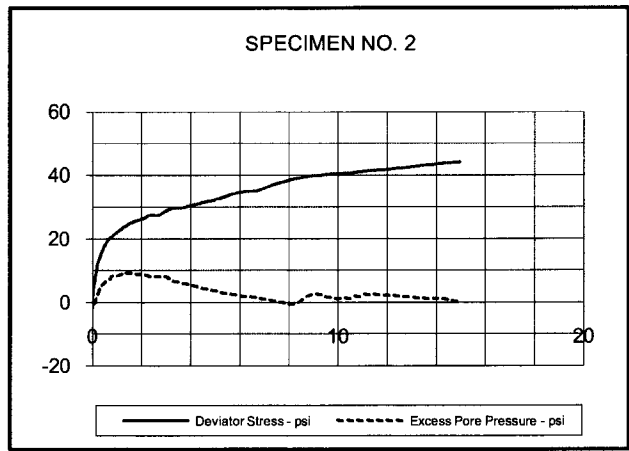
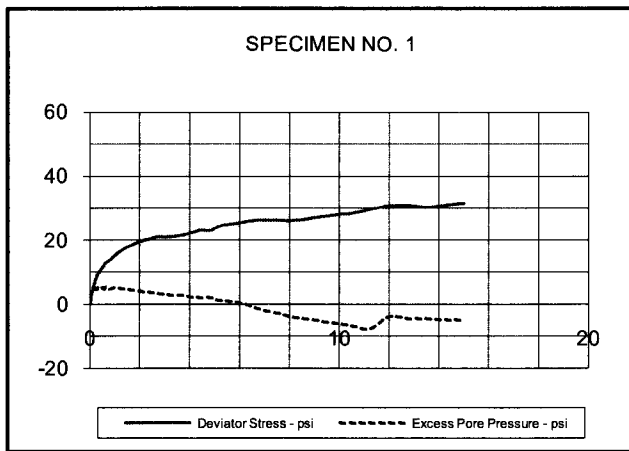

EFFECTIVE STRESS PARAMETERS	$R^2 = 1.00$	α (deg) = 27.9	a (psi) = 1.1
PROJECT: Martin Lake PDP 1 - 3 Supplemental		TYPE OF TEST & NO: CU with PP	
PROJECT NO: G 3219 - 09		ETTL ENGINEERS & CONSULTANTS	PLATE: B.2
DESCRIPTION: Tan w/ Red & Gray Clayey Sand			

G 3219-09, B-16 8'-10' Native

TRIAxIAL SHEAR TEST REPORT

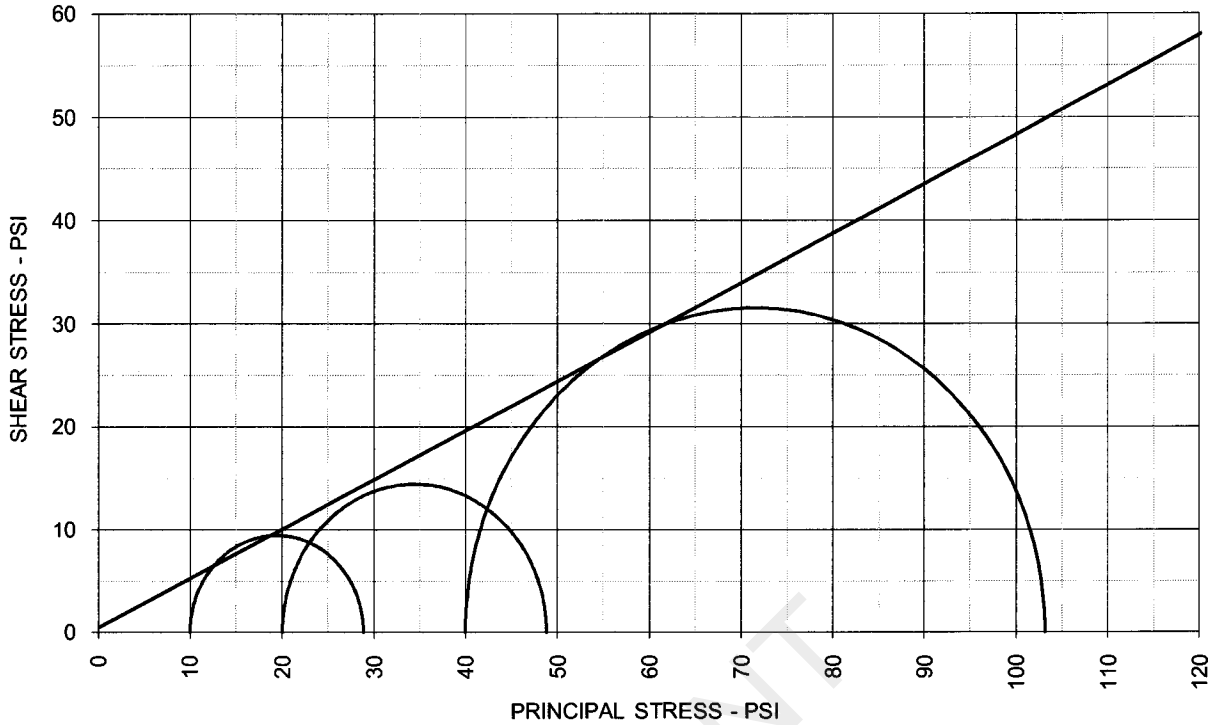

TOTAL STRESS PARAMETERS		$\phi = 25.6 \text{ deg}$		$c = 0.5 \text{ psi}$		
		SPECIMEN NO.				
		1	2	3	4	
		INITIAL				
		Moisture Content - %	17.2	16.8	16.3	
		Dry Density - pcf	112.6	114.4	115.0	
		Diameter - inches	2.47	2.46	2.48	
		Height - inches	4.98	4.97	5.00	
		AT TEST				
		Final Moisture - %	18.4	16.5	16.0	
		Dry Density - pcf	113.1	115.3	116.9	
		Calculated Diameter (in.)	2.47	2.46	2.50	
		Height - inches	5.00	4.97	5.06	
Effect. Cell Pressure - psi	10.0	20.0	40.0			
Failure Stress - psi	18.88	28.83	63.14			
Total Pore Pressure - psi	54.3	58.2	64.1			
Strain Rate - inches/min.	0.00050	0.00050	0.00050			
Failure Strain - %	1.8	3.0	5.2			
σ_1 Failure - psi	28.88	48.83	103.14			
σ_3 Failure - psi	10.00	20.00	40.00			

TEST DESCRIPTION	PROJECT INFORMATION
TYPE OF TEST & NO: CU with PP SAMPLE TYPE: Native Shelby Tube Sample DESCRIPTION: Tan w/ Red & Gray Clayey Sand Sampled on Site, B-16 8' to 10' deep ASSUMED SPECIFIC GRAVITY: 2.7 + 40 Sieve LL: PL: PI: Percent -200: REMARKS: Diameter and Both Ends Trimmed + # 4 Sieve	PROJECT: Martin Lake PDP 1 - 3 Supplemental LOCATION: PROJECT NO: G 3219 - 09 CLIENT: HDR September 2009 <div style="display: flex; justify-content: space-between; margin-top: 10px;"> Ettl ENGINEERS & CONSULTANTS PLATE: B.3 </div>

PROJECT INFORMATION

PROJECT: Martin Lake PDP 1 - 3 Supplemental
LOCATION:
PROJECT NO: G 3219 - 09
CLIENT: HDR
September 2009

TRIAxIAL TEST PROGRAM BY GARRY H. GREGORY, P.E.

ALL RIGHTS RESERVED - UNAUTHORIZED USE PROHIBITED
VERSION 1.0 - AUGUST 1998 - REVISED MARCH 24, 1999

THIS COPY LICENSED TO:
ETTL ENGINEERS AND CONSULTANTS, INC.
1717 East Erwin
Tyler, TX 75702

TEST DESCRIPTION

TYPE OF TEST & NO: CU with PP
SAMPLE TYPE: Native Shelby Tube Sample
DESCRIPTION: Tan & Red Sandy Lean Clay
Sampled on Site, B-17 3' to 7' deep
ASSUMED SPECIFIC GRAVITY: 2.7 + 40 Sieve
LL: PL: Pt: Percent -200:
REMARKS: Diameter and Both Ends Trimmed + # 4 Sieve

PLATE: B.1

PLATE: B.2

PLATE: B.3

Number of Specimens = 3

TRIAxIAL SHEAR TEST REPORT

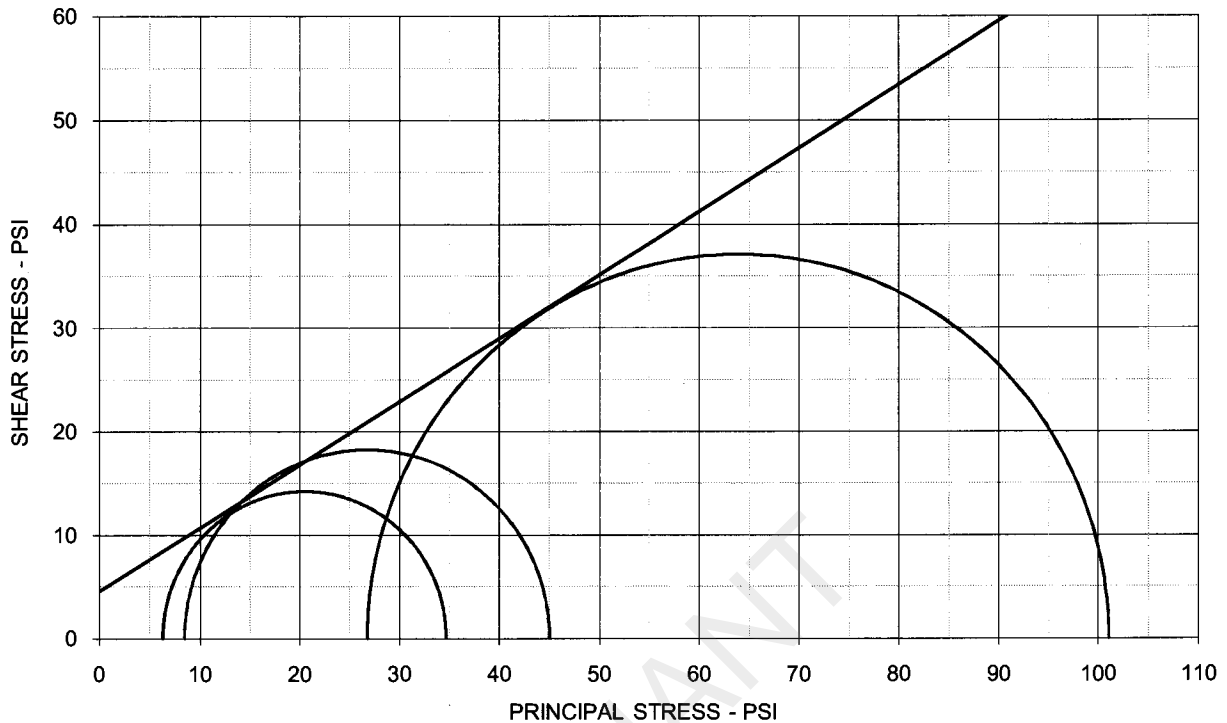

EFFECTIVE STRESS PARAMETERS

$\phi' = 31.4$ deg $c' = 4.6$ psi

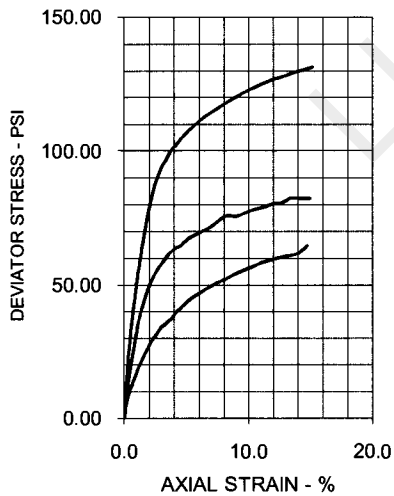

SPECIMEN NO.	1	2	3	4
INITIAL				
Moisture Content - %	16.2	13.3	13.9	
Dry Density - pcf	113.5	121.6	115.5	
Diameter - inches	2.49	2.49	2.50	
Height - inches	5.08	5.00	5.16	
AT TEST				
Final Moisture - %	18.1	14.7	16.3	
Dry Density - pcf	114.1	123.3	117.2	
Calculated Diameter (in.)	2.50	2.50	2.52	
Height - inches	5.10	5.04	5.22	
Effect. Cell Pressure - psi	10.0	20.0	40.0	
Failure Stress - psi	28.40	36.54	74.24	
Total Pore Pressure - psi	53.7	61.5	63.2	
Strain Rate - inches/min.	0.00050	0.00050	0.00050	
Failure Strain - %	0.8	3.5	1.8	
σ'_1 Failure - psi	34.71	45.04	101.03	
σ'_3 Failure - psi	6.31	8.50	26.79	

TEST DESCRIPTION

TYPE OF TEST & NO: CU with PP
 SAMPLE TYPE: Native Shelby Tube Sample
 DESCRIPTION: Tan & Red Sandy Lean Clay
 Sampled on Site, B-17 3' to 7' deep
 ASSUMED SPECIFIC GRAVITY: 2.7 + 40 Sieve
 LL: PL: PI: Percent -200:
 REMARKS: Diameter and Both Ends Trimmed + # 4 Sieve
 G 3219-09, B-17 3-7 Native

PROJECT INFORMATION

PROJECT: Martin Lake PDP 1 - 3 Supplemental
 LOCATION:
 PROJECT NO: G 3219 - 09
 CLIENT: HDR
 September 2009

ETTL ENGINEERS & CONSULTANTS

PLATE: B.1

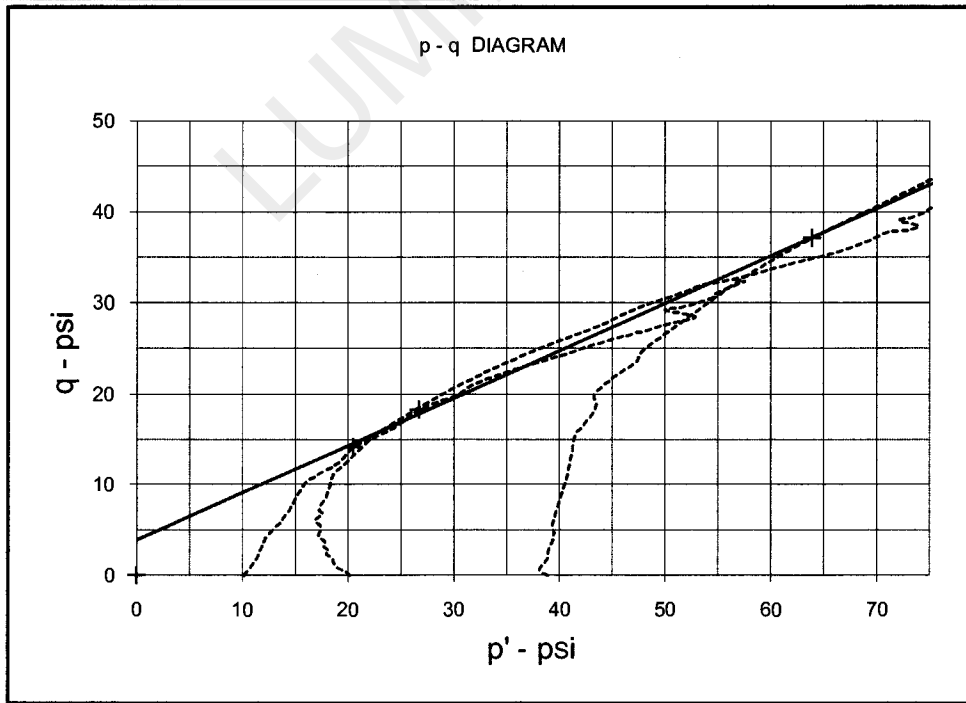
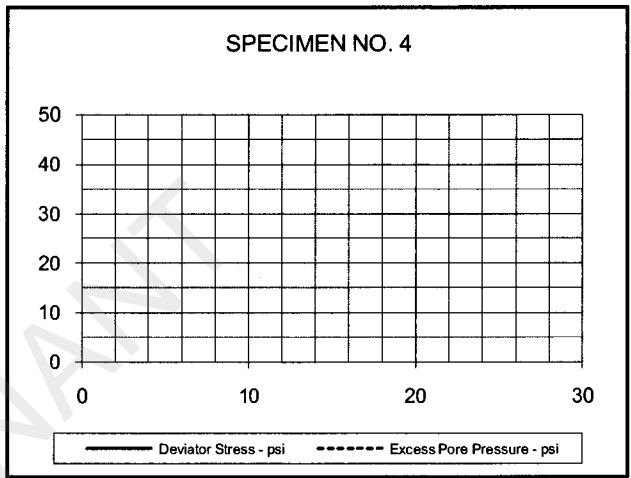
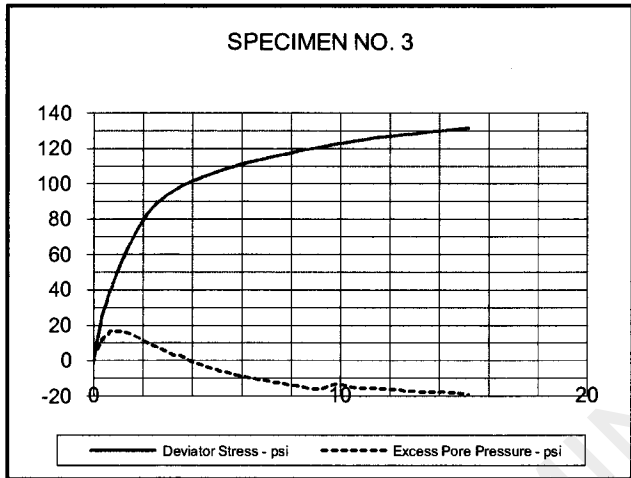
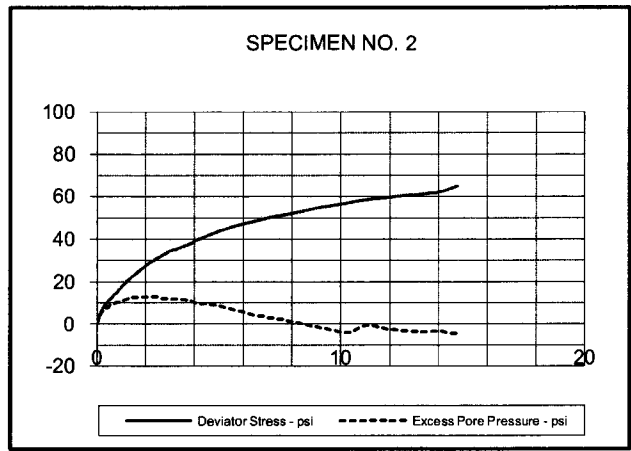
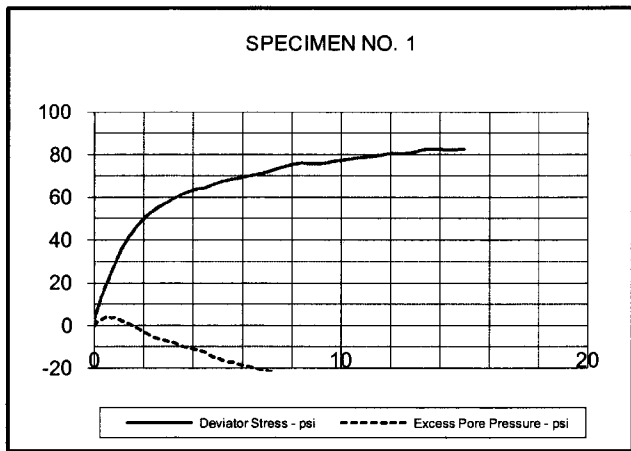

EFFECTIVE STRESS PARAMETERS	$R^2 = 1.00$	α (deg) = 27.5	a (psi) = 3.9
PROJECT: Martin Lake PDP 1 - 3 Supplemental		TYPE OF TEST & NO: CU with PP	
PROJECT NO: G 3219 - 09		ETTL ENGINEERS & CONSULTANTS	PLATE: B.2
DESCRIPTION: Tan & Red Sandy Lean Clay			

G 3219-09, B-17 3'-7' Native

TRIAxIAL SHEAR TEST REPORT

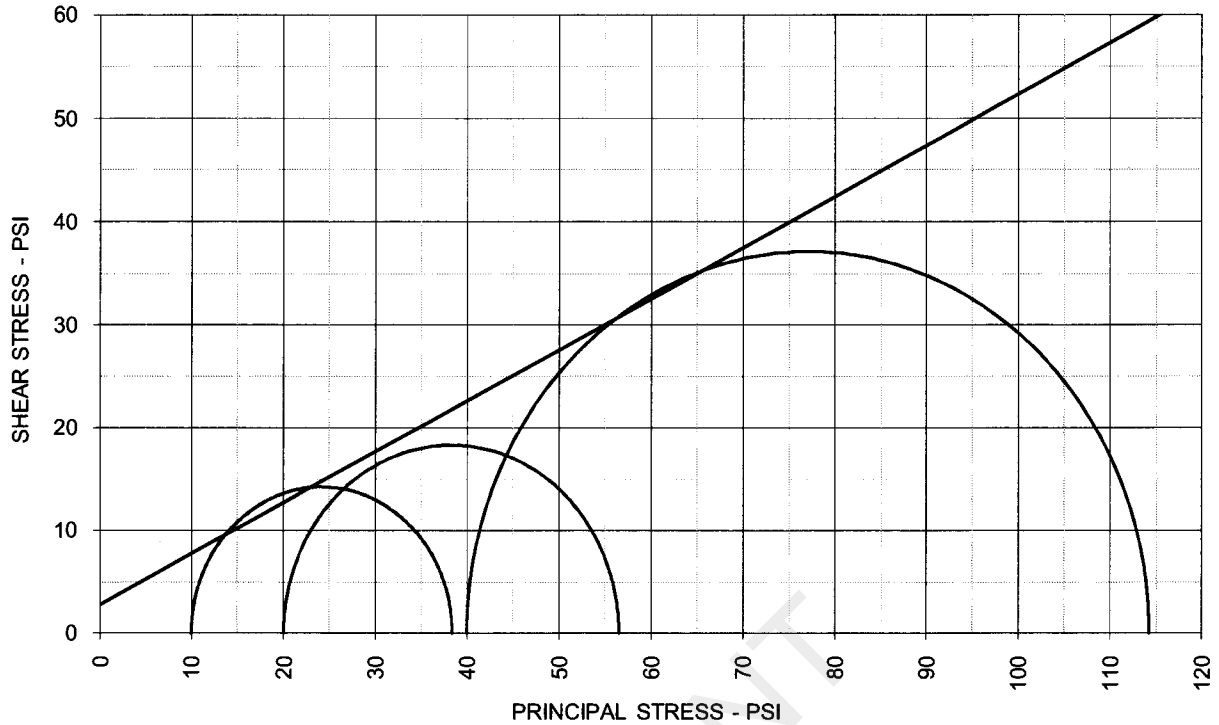

TOTAL STRESS PARAMETERS		$\phi =$ 26.4 deg	$c =$ 2.8 psi			
	SPECIMEN NO.	1	2	3	4	
	INITIAL					
	Moisture Content - %	16.2	13.3	13.9		
	Dry Density - pcf	113.5	121.6	115.5		
	Diameter - inches	2.49	2.49	2.50		
	Height - inches	5.08	5.00	5.16		
	AT TEST					
	Final Moisture - %	18.1	14.7	16.3		
	Dry Density - pcf	114.1	123.3	117.2		
	Calculated Diameter (in.)	2.50	2.50	2.52		
Height - inches	5.10	5.04	5.22			
Effect. Cell Pressure - psi	10.0	20.0	40.0			
Failure Stress - psi	28.40	36.54	74.24			
Total Pore Pressure - psi	53.7	61.5	63.2			
Strain Rate - inches/min.	0.00050	0.00050	0.00050			
Failure Strain - %	0.8	3.5	1.8			
σ_1 Failure - psi	38.40	56.54	114.24			
σ_3 Failure - psi	10.00	20.00	40.00			
TEST DESCRIPTION		PROJECT INFORMATION				
TYPE OF TEST & NO: CU with PP SAMPLE TYPE: Native Shelby Tube Sample DESCRIPTION: Tan & Red Sandy Lean Clay Sampled on Site, B-17 3' to 7' deep ASSUMED SPECIFIC GRAVITY: 2.7 + 40 Sieve LL: PL: PI: Percent -200: REMARKS: Diameter and Both Ends Trimmed + # 4 Sieve		PROJECT: Martin Lake PDP 1 - 3 Supplemental LOCATION: PROJECT NO: G 3219 - 09 CLIENT: HDR September 2009				
		ETTL ENGINEERS & CONSULTANTS		PLATE: B.3		

PROJECT INFORMATION

PROJECT: Martin Lake PDP 1 - 3 Supplemental
LOCATION:
PROJECT NO: G 3219 - 09
CLIENT: HDR
September 2009

TRIAxIAL TEST PROGRAM BY GARRY H. GREGORY, P.E.

ALL RIGHTS RESERVED - UNAUTHORIZED USE PROHIBITED
VERSION 1.0 - AUGUST 1998 - REVISED MARCH 24, 1999

THIS COPY LICENSED TO:
ETTL ENGINEERS AND CONSULTANTS, INC.
1717 East Erwin
Tyler, TX 75702

TEST DESCRIPTION

TYPE OF TEST & NO: CU with PP
SAMPLE TYPE: Lab Molded
DESCRIPTION: Tan & Reddish Tan Silty Sand
Sampled on Site, TP- 31 0' to 5' deep
ASSUMED SPECIFIC GRAVITY: 2.7 + 40 Sieve 2%
LL: 20 PL: 17 Pt: 3 Percent -200: 27%
REMARKS: Both Ends Trimmed + # 4 Sieve 1%

PLATE: B.1

PLATE: B.2

PLATE: B.3

Number of Specimens = 3

LUMINANT

TRIAXIAL SHEAR TEST REPORT

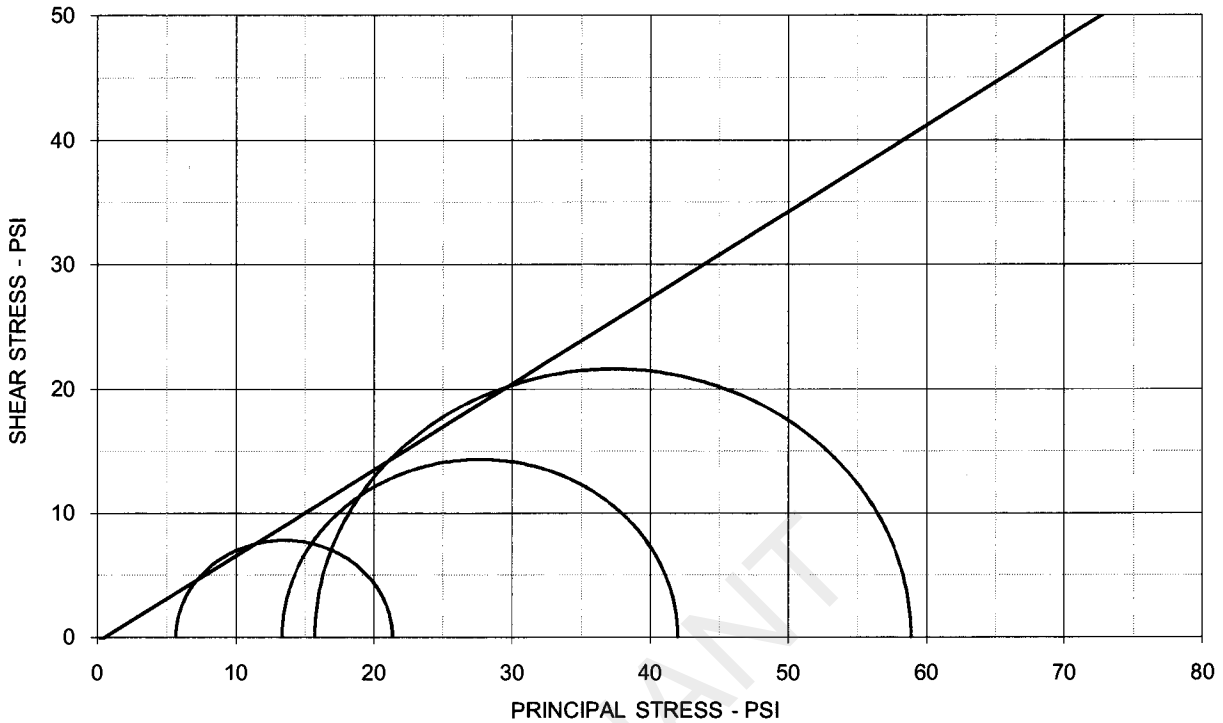

EFFECTIVE STRESS PARAMETERS

$\phi' = 34.7 \text{ deg}$

$c' = -0.4 \text{ psi}$

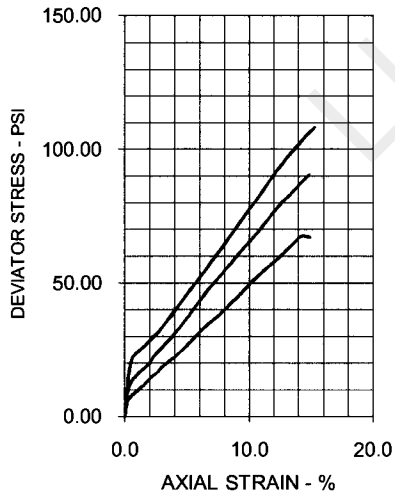

SPECIMEN NO.

1 2 3 4

INITIAL

Moisture Content - %	17.3	17.2	17.4
Dry Density - pcf	110.3	110.5	110.4
Diameter - inches	2.87	2.87	2.85
Height - inches	5.57	5.59	5.61

AT TEST

Final Moisture - %	17.2	16.7	16.5
Dry Density - pcf	110.6	111.6	112.0
Calculated Diameter (in.)	2.87	2.88	2.87
Height - inches	5.58	5.62	5.66
Effect. Cell Pressure - psi	10.0	20.0	40.0
Failure Stress - psi	15.65	28.63	43.17
Total Pore Pressure - psi	54.3	56.7	74.3
Strain Rate - inches/min.	0.00050	0.00050	0.00050
Failure Strain - %	2.4	3.5	4.6
σ_1' Failure - psi	21.35	41.97	58.90
σ_3' Failure - psi	5.70	13.34	15.73

TEST DESCRIPTION

TYPE OF TEST & NO: CU with PP
 SAMPLE TYPE: Lab Molded
 DESCRIPTION: Tan & Reddish Tan Silty Sand
 Sampled on Site, TP- 31 0' to 5' deep
 ASSUMED SPECIFIC GRAVITY: 2.7 + 40 Sieve 2%
 LL: 20 PL: 17 PI: 3 Percent -200: 27%
 REMARKS: Both Ends Trimmed + # 4 Sieve 1%
 G 3219-09, TP-31 0-5 Lab Molded

PROJECT INFORMATION

PROJECT: Martin Lake PDP 1 - 3 Supplemental
 LOCATION:
 PROJECT NO: G 3219 - 09
 CLIENT: HDR
 September 2009

ETTL ENGINEERS & CONSULTANTS

PLATE: B.1

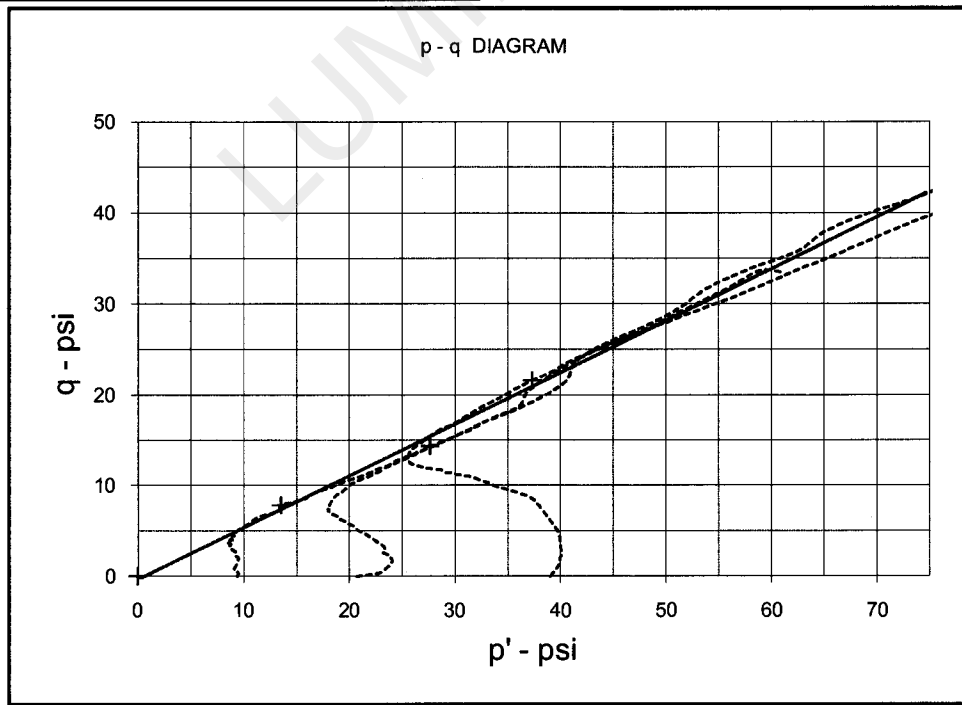
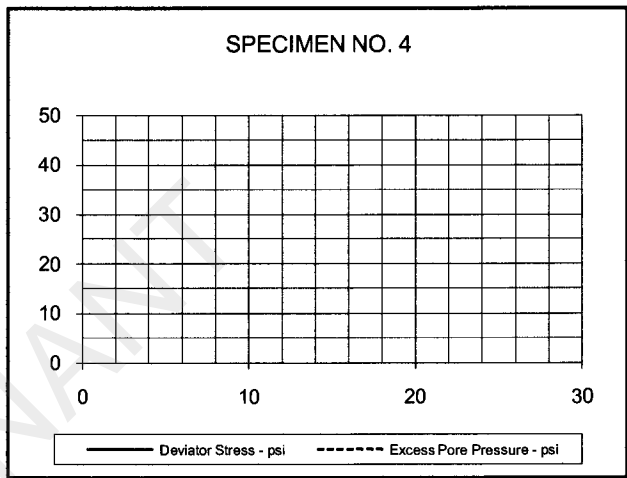
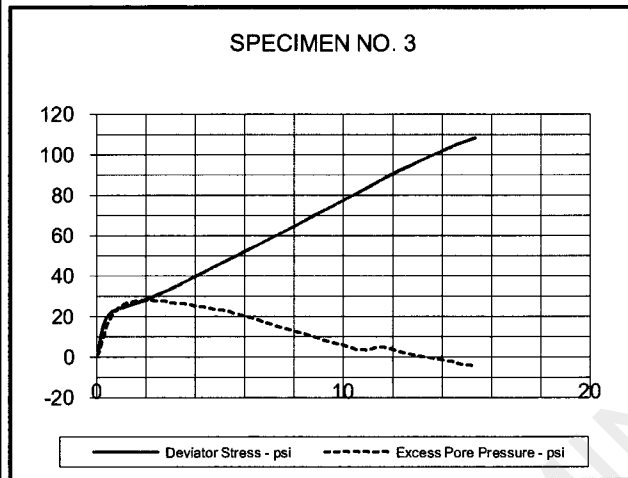
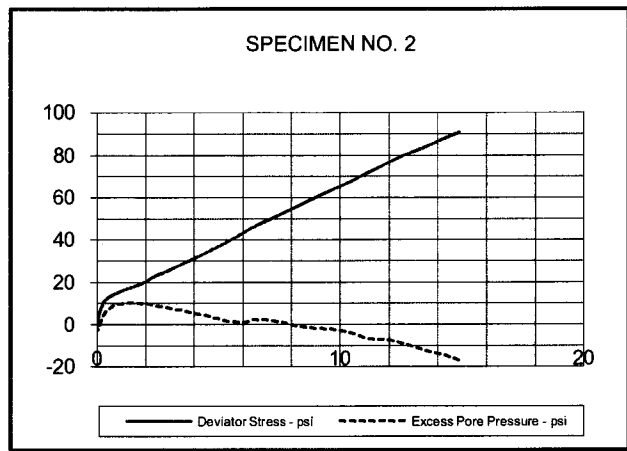
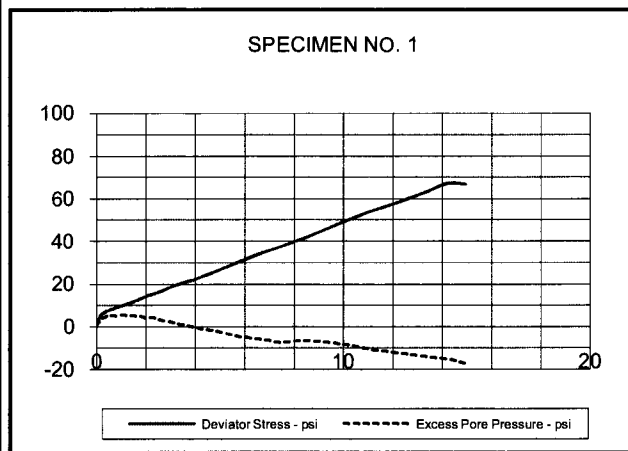

EFFECTIVE STRESS PARAMETERS	$R^2 = 0.98$	α (deg) = 29.7	a (psi) = -0.3
PROJECT: Martin Lake PDP 1 - 3 Supplemental	TYPE OF TEST & NO: CU with PP		
PROJECT NO: G 3219 - 09	ETTL ENGINEERS & CONSULTANTS		PLATE: B.2
DESCRIPTION: Tan & Reddish Tan Silty Sand			

G 3219-09, TP-31 0'-5' Lab Molded

TRIAxIAL SHEAR TEST REPORT

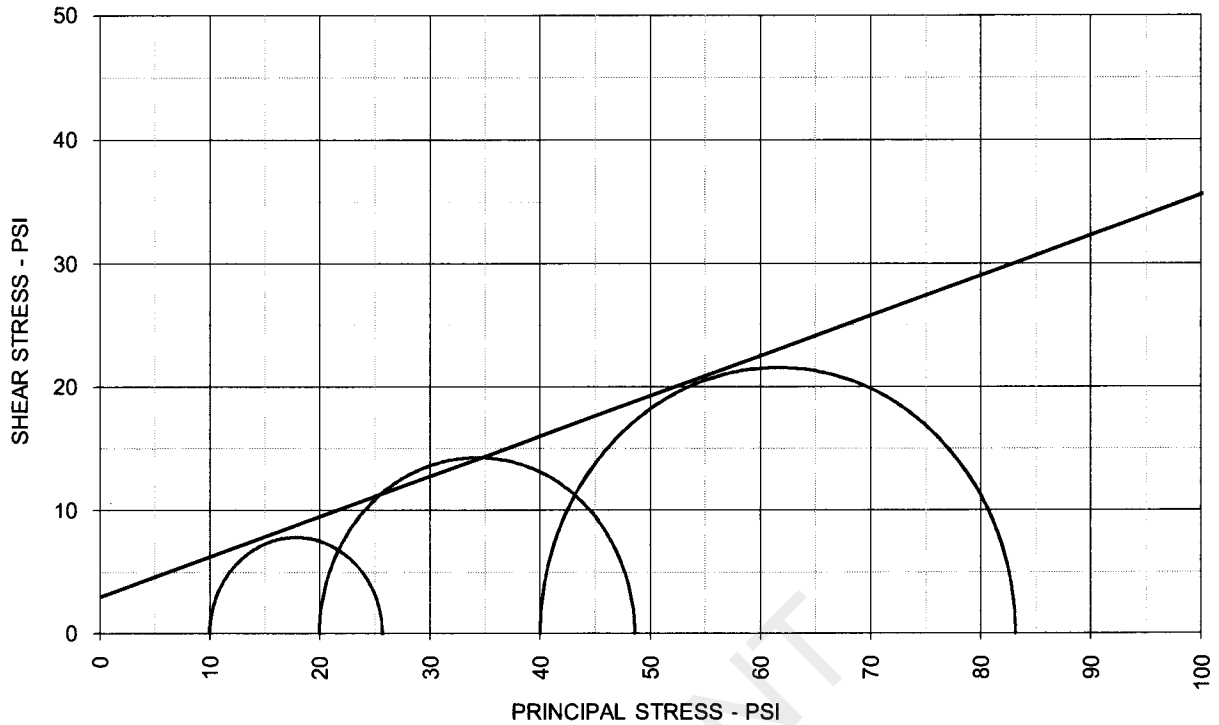

TOTAL STRESS PARAMETERS		$\phi = 18.0 \text{ deg}$		$c = 3.0 \text{ psi}$		
	SPECIMEN NO.	1	2	3	4	
	INITIAL					
	Moisture Content - %	17.3	17.2	17.4		
	Dry Density - pcf	110.3	110.5	110.4		
	Diameter - inches	2.87	2.87	2.85		
	Height - inches	5.57	5.59	5.61		
	AT TEST					
	Final Moisture - %	17.2	16.7	16.5		
	Dry Density - pcf	110.6	111.6	112.0		
	Calculated Diameter (in.)	2.87	2.88	2.87		
Height - inches	5.58	5.62	5.66			
Effect. Cell Pressure - psi	10.0	20.0	40.0			
Failure Stress - psi	15.65	28.63	43.17			
Total Pore Pressure - psi	54.3	56.7	74.3			
Strain Rate - inches/min.	0.00050	0.00050	0.00050			
Failure Strain - %	2.4	3.5	4.6			
σ_1 Failure - psi	25.65	48.63	83.17			
σ_3 Failure - psi	10.00	20.00	40.00			
TEST DESCRIPTION			PROJECT INFORMATION			
TYPE OF TEST & NO: CU with PP SAMPLE TYPE: Lab Molded DESCRIPTION: Tan & Reddish Tan Silty Sand Sampled on Site, TP- 31 0' to 5' deep ASSUMED SPECIFIC GRAVITY: 2.7 + 40 Sieve 2% LL: 20 PL: 17 PI: 3 Percent -200: 27% REMARKS: Both Ends Trimmed + # 4 Sieve 1%			PROJECT: Martin Lake PDP 1 - 3 Supplemental LOCATION: PROJECT NO: G 3219 - 09 CLIENT: HDR September 2009			
			ETTL ENGINEERS & CONSULTANTS	PLATE: B.3		

TRIAXIAL SHEAR TEST REPORT

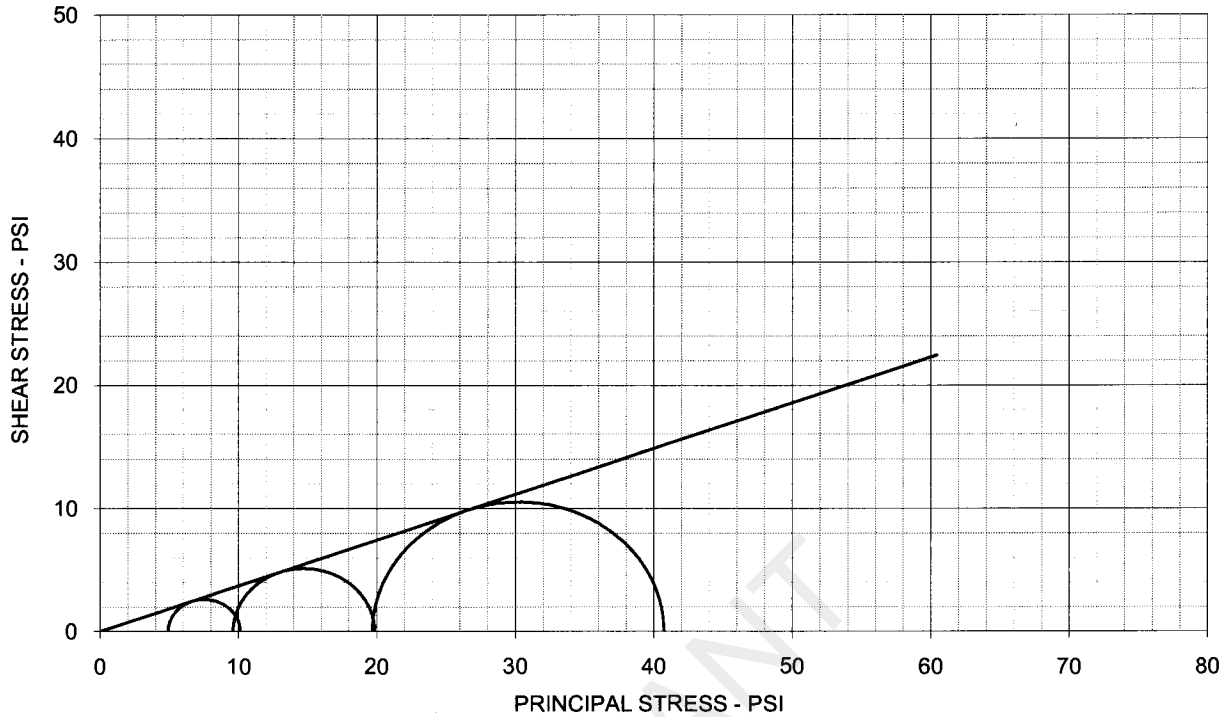

EFFECTIVE STRESS PARAMETERS

$\phi' = 20.4 \text{ deg}$ $c' = 0.0 \text{ psi}$

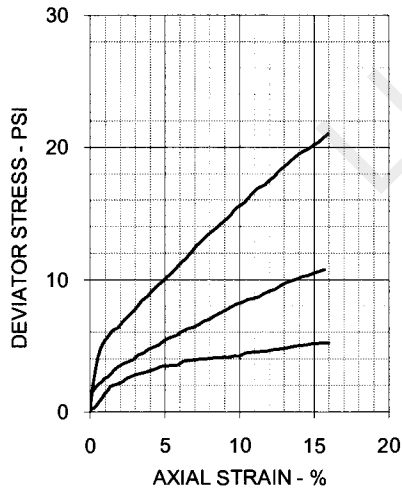

SPECIMEN NO.	1	2	3	4
INITIAL				
Moisture Content - %	26.1	24.6	21.3	
Dry Density - pcf	94.3	95.8	101.6	
Diameter - inches	1.40	1.40	1.40	
Height - inches	2.81	2.85	3.20	
AT TEST				
Final Moisture - %	26.1	24.6	21.3	
Dry Density - pcf	94.3	97.0	101.6	
Calculated Diameter (in.)	1.40	1.40	1.40	
Height - inches	2.81	2.85	3.20	
Effect. Cell Pressure - psi	5.0	10.0	20.0	
Failure Stress - psi	5.21	10.25	21.03	
Total Pore Pressure - psi	20.0	20.0	20.0	
Strain Rate - inches/min.	0.00050	0.00050	0.00050	
Failure Strain - %	15.6	14.2	15.9	
σ_1' Failure - psi	10.11	19.85	40.73	
σ_3' Failure - psi	4.90	9.60	19.70	

TEST DESCRIPTION

TYPE OF TEST & NO: CD Triaxial - CD-1
 SAMPLE TYPE: SHELBY TUBE
 DESCRIPTION: SANDY LEAN CLAY (CL), tan br w/ red br and gray
 SAMPLE LOCATION: B-16, 3-5'
 ASSUMED SPECIFIC GRAVITY: 2.70
 LL: 43 PL: 14 PI: 29 Percent -200: 56
 REMARKS: Tested in a fully softened remolded state

PROJECT INFORMATION

PROJECT: Luminant Martin Lake PDP 1-3 Vertical Expansion
 LOCATION: Tatum, TX
 PROJECT NO: ETT08002-11
 CLIENT: E TTL Engineers & Consultants, Inc.
 DATE: 9/15/09

GREGORY GEOTECHNICAL

PLATE: B-CD.1

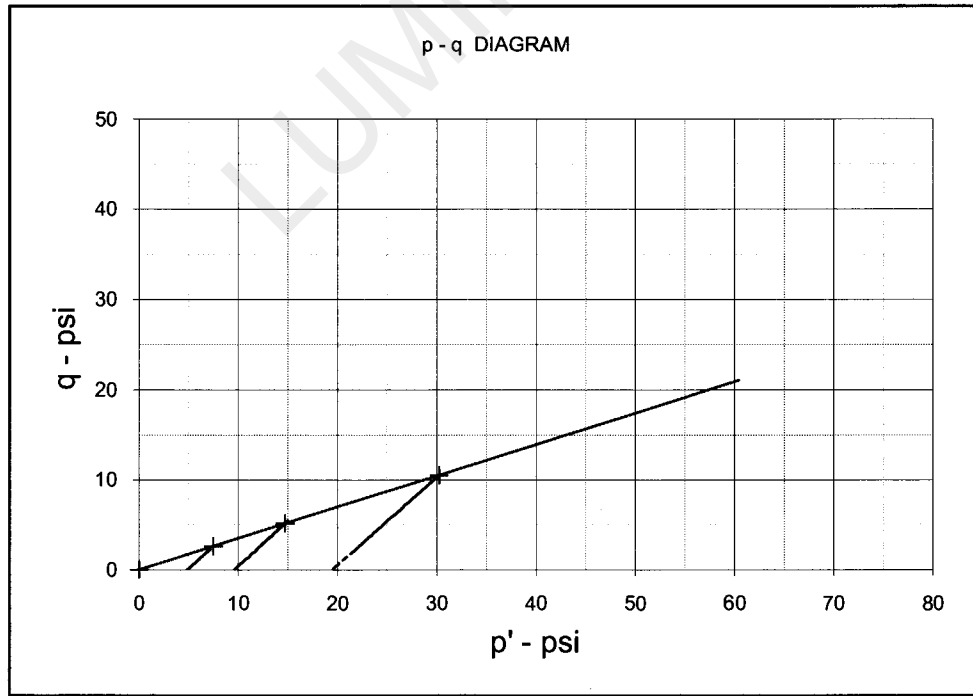
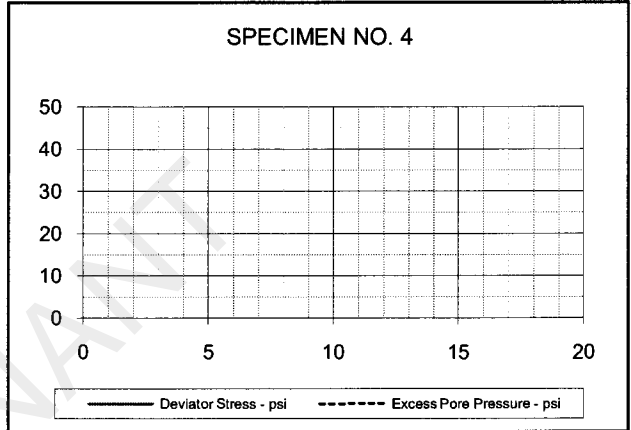
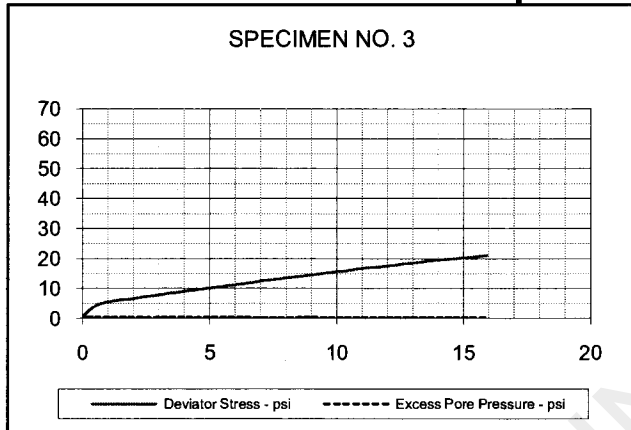
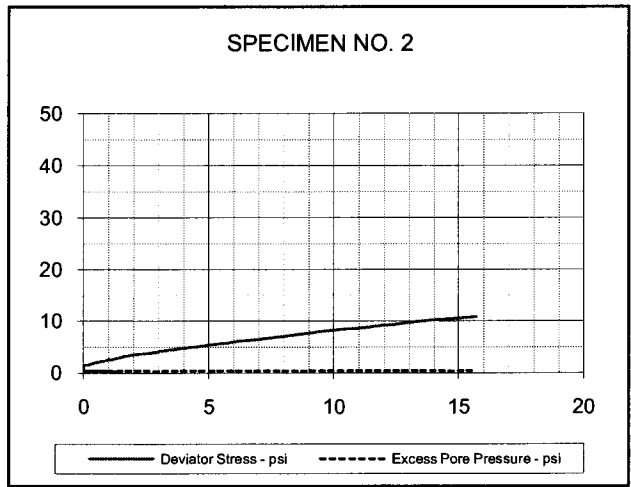
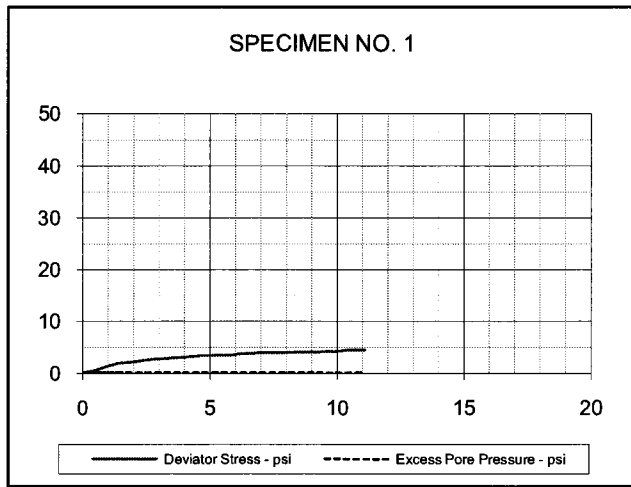

EFFECTIVE STRESS PARAMETERS	R ² = 1.000	α (deg) = 19.2	a (psi) = 0.0
PROJECT: Luminant Martin Lake PDP 1-3 Vertical Expansion		TYPE OF TEST & NO: CD Triaxial - CD-1	
PROJECT NO: ETT08002-11		GREGORY GEOTECHNICAL PLATE: B-CD.2	
DESCRIPTION: SANDY LEAN CLAY (CL), tan br w/ red br and gray			

DIRECT SHEAR TEST REPORT

$y = 0.815x + 1.35$
 $R^2 = 0.980$

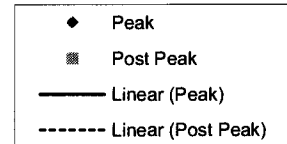
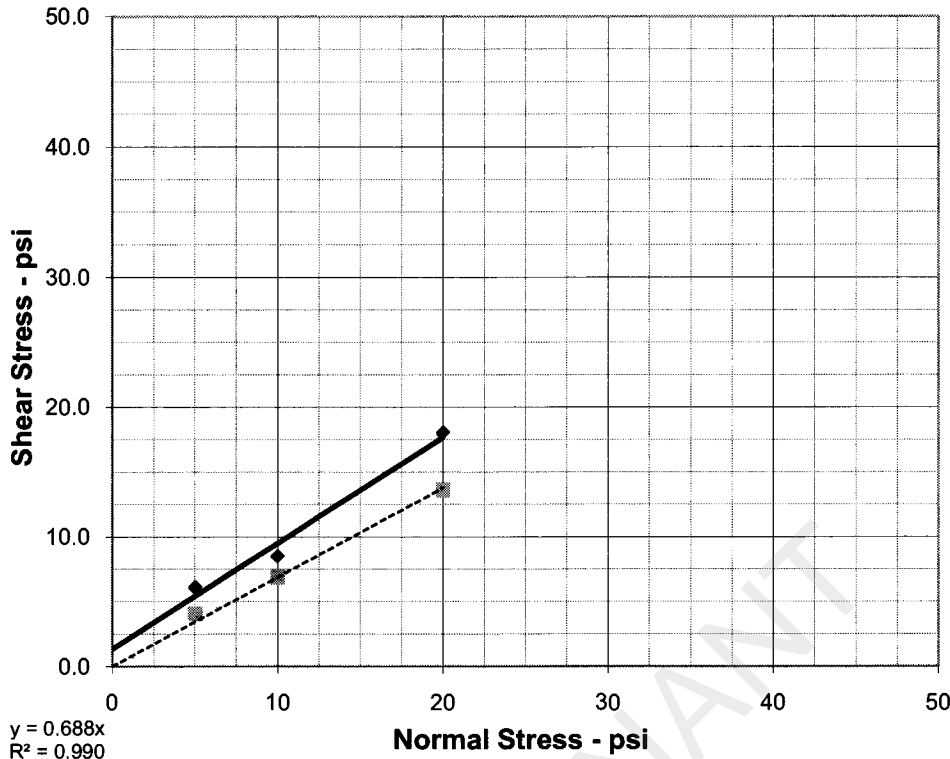

PEAK STRENGTH PARAMETERS	$\phi = 39.2 \text{ deg}$	$c = 1.4 \text{ psi}$	
POST PEAK STRENGTH PARAMETERS	$\phi = 34.6 \text{ deg}$	$c = 0.0 \text{ psi}$	

	SPECIMEN NO.	1	2	3	4	
	INITIAL					
	Moisture Content - %	41.3	42.3	48.4		
	Dry Density - pcf	78.9	72.5	72.9		
	Diameter - inches	2.50	2.50	2.50		
	Height - inches	1.00	1.00	1.00		
	AT TEST					
	Final Moisture - %	46.6	59.5	31.6		
	Dry Density - pcf	81.0	74.2	73.0		
	Height-End of Consol. (in.)	1.03	1.02	1.00		
Height-End of Shear (in.)	1.03	1.03	1.01			
Normal Stress - psi	5.0	10.0	20.0			
Peak Failure Stress-psi	6.1	8.5	18.0			
Post Peak Failure Stress-psi	4.1	6.9	13.6			
Strain Rate - inches/min.	0.00030	0.00030	0.00030			
Peak Failure Strain - %	1.6	1.9	3.1			
Post Peak Failure Strain %	4.3	12.7	11.8			
Dry Density at test based on initial moisture and height at end of consolidation.						

TEST DESCRIPTION	PROJECT INFORMATION	
TYPE OF TEST & NO: CD-DS-1 SAMPLE TYPE: Shelby Tube DESCRIPTION: SILT(MH), black (classification tests from 13-15 ft) SAMPLE LOCATION: B-15, 18-20 ft ASSUMED SPECIFIC GRAVITY: 2.65 LL: NP PL: NP PI: NP Percent -200: 95 REMARKS: Tested at natural MC	PROJECT: Luminant Martin Lake PDP 1-3 Vertical Expansion LOCATION: Tatum, TX PROJECT NO: ETT08002-11 (G3219-09) CLIENT: Ettl Engineers & Consultants, Inc DATE: 9/25/09	
	GREGORY GEOTECHNICAL	PLATE: B-DS. 1

DIRECT SHEAR TEST REPORT

$y = 0.788x + 1.4$
 $R^2 = 0.99$

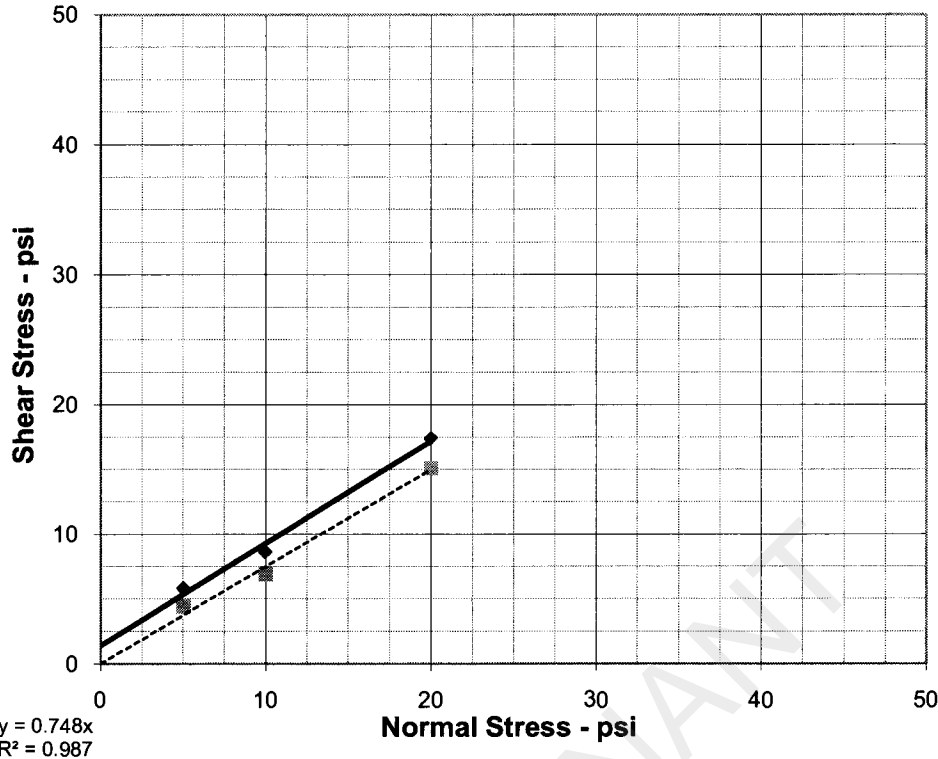

PEAK STRENGTH PARAMETERS	$\phi = 38.3 \text{ deg}$	$c = 1.4 \text{ psi}$
POST PEAK STRENGTH PARAMETERS	$\phi = 36.8 \text{ deg}$	$c = 0.0 \text{ psi}$

	SPECIMEN NO.	1	2	3	4	
	INITIAL					
	Moisture Content - %	47.2	47.5	46.5		
	Dry Density - pcf	77.0	73.3	72.6		
	Diameter - inches	2.50	2.50	2.50		
	Height - inches	1.00	1.00	1.00		
	AT TEST					
	Final Moisture - %	47.2	47.5	31.6		
	Dry Density - pcf	77.0	73.3	72.6		
	Height-End of Consol. (in.)	1.00	1.00	1.00		
Height-End of Shear (in.)	0.98	0.98	0.99			
Normal Stress - psi	5.0	10.0	20.0			
Peak Failure Stress-psi	5.8	8.6	17.4			
Post Peak Failure Stress-psi	4.4	6.9	15.1			
Strain Rate - inches/min.	0.00030	0.00030	0.00030			
Peak Failure Strain - %	3.1	15.0	3.1			
Post Peak Failure Strain %	7.8	6.8	12.8			
Dry Density at test based on initial moisture and height at end of consolidation.						

TEST DESCRIPTION	PROJECT INFORMATION		
TYPE OF TEST & NO: CD-DS-2 SAMPLE TYPE: Shelby Tube DESCRIPTION: SILT(MH), black (classification tests from 13-15 ft) SAMPLE LOCATION: B-15, 18-20 ft ASSUMED SPECIFIC GRAVITY: 2.65 LL: NP PL: NP PI: NP Percent -200: 95 REMARKS: Tested in a fully softened remolded state	PROJECT: Luminant Martin Lake PDP 1-3 Vertical Expansion LOCATION: Tatum, TX PROJECT NO: ETT08002-11 (G3219-09) CLIENT: E TTL Engineers & Consultants, Inc DATE: 9/23/09		
	<table border="1" style="width: 100%; border-collapse: collapse;"> <tr> <td style="width: 50%; text-align: center;">GREGORY GEOTECHNICAL</td> <td style="width: 50%; text-align: center;">PLATE: B-DS. 2</td> </tr> </table>	GREGORY GEOTECHNICAL	PLATE: B-DS. 2
GREGORY GEOTECHNICAL	PLATE: B-DS. 2		



ETTL Engineers & Consultants Inc.

GEOTECHNICAL * MATERIALS * ENVIRONMENTAL * DRILLING * LANDFILLS

HYDRAULIC CONDUCTIVITY DETERMINATION FLEXIBLE WALL PERMEAMETER - CONSTANT VOLUME (Mercury Permometer Test)

Project :	Martin Lake PDP 1 - 3 Supplemental, Tatum, Texas		
Date:	8/26/2009	Panel Number :	P 1 ; ASTM D 5084
Project No. :	G 3219-09	Permometer Data	
Boring No.:	B - 14	ap =	0.031416 cm ²
Sample:		aa =	0.767120 cm ²
Depth (ft):	3' to 5'	M1 =	0.030180
Other Location:		M2 =	1.040953
Material Description :	Dark Gray Ash		

Set Mercury to Dinat Dn at	Equilibrium	1.8	cm ³
	Pipet Rp	6.7	cm ³
	Annulus Ra	1.5	cm ³
	C =	0.000414194	
	T =	0.203859738	

SAMPLE DATA

Wet Wt. sample + ring or tare :	502.16	g			
Tare or ring Wt. :	0.0	g			
Wet Wt. of Sample :	502.16	g			
Diameter :	2.85	in	7.24	cm ²	
Length :	2.80	in	7.12	cm	
Area:	6.38	in ²	41.16	cm ²	
Volume :	17.88	in ³	292.92	cm ³	
Unit Wt. (wet):	106.97	pcf	1.71	g/cm ³	
Unit Wt. (dry):	68.77	pcf	1.10	g/cm ³	

	Before Test	After Test
Tare No.:	T 20	T 22
Wet Wt. +tare:	522.84	625.95
Dry Wt. +tare:	393.34	480.79
Tare Wt:	160.27	140.47
Dry Wt.:	233.07	340.32
Water Wt.:	129.5	145.16
% moist.:	55.6	42.7

Specific Gravity:	2.60	Max Dry Density(pcf) =	68.7952	OMC =	55.5627065
		% of max =	100.0	+/- OMC =	0.00
Calculated % saturation:	81.52	Void ratio (e) =	1.36	Porosity (n) =	0.58

TEST READINGS

Z1(Mercury Height Difference @ t1):	5.1	cm	Hydraulic Gradient =	9.04
-------------------------------------	-----	----	----------------------	------

Date	elapsed t (seconds)	Z (pipet @ t)	$\Delta Z\pi$ (cm)	temp (deg C)	α (temp corr)	k (cm/sec)	k (ft./day)	Reset = *
8/26/2009	8	4.5	2.1553335	25	0.889	2.66E-05	7.55E-02	
8/26/2009	10	4.05	2.6053335	25	0.889	2.79E-05	7.91E-02	
8/26/2009	12	3.6	3.0553335	25	0.889	2.99E-05	8.48E-02	
8/26/2009	14	3.25	3.4053335	25	0.889	3.12E-05	8.84E-02	

SUMMARY

ka =	2.89E-05	cm/sec	Acceptance criteria =	25 %
ki			Vm	
k1 =	2.66E-05	cm/sec	7.8	%
k2 =	2.79E-05	cm/sec	3.5	%
k3 =	2.99E-05	cm/sec	3.5	%
k4 =	3.12E-05	cm/sec	7.8	%

Hydraulic conductivity	k =	2.89E-05	cm/sec	8.19E-02	ft/day
Void Ratio	e =	1.36			
Porosity	n =	0.58			
Bulk Density	γ =	1.71	g/cm ³	107.0	pcf
Water Content	W =	0.61	cm ³ /cm ³	(at 20 deg C)	
Intrinsic Permeability	kint =	2.96E-10	cm ²	(at 20 deg C)	

Liquid Limit LL		
Plastic Limit PL		
Plasticity Index PI		
- 200 Sieve		%
+ No 40 Sieve		%
+ No 4 Sieve		%

Respectfully Submitted

Robert M. Duke, P.E.



ETTL Engineers & Consultants Inc.

GEOTECHNICAL * MATERIALS * ENVIRONMENTAL * DRILLING * LANDFILLS

HYDRAULIC CONDUCTIVITY DETERMINATION FLEXIBLE WALL PERMEAMETER - CONSTANT VOLUME (Mercury Permometer Test)

Project : Martin Lake PDP 1 - 3 Supplemental, Tatum, Texas
 Date: 8/26/2009 Panel Number : P 2 ; ASTM D 5084
 Project No. : G 3219-09 Permeometer Data
 Boring No.: B - 14 ap = 0.031416 cm2 Set Mercury to Equilibrium 1.8 cm3
 Sample: aa = 0.767120 cm2 Diam Per at Pipet Rp 6.7 cm3
 Depth (ft): 16' to 17' M1 = 0.030180 C = 0.000414194 Annulus Ra 1.5 cm3
 Other Location: M2 = 1.040953 T = 0.203859738

Material Description : Dark Gray Ash

SAMPLE DATA

Wet Wt. sample + ring or tare :	<u>457.47</u> g		
Tare or ring Wt. :	<u>0.0</u> g		
Wet Wt. of Sample :	<u>457.47</u> g	Before Test	After Test
Diameter :	<u>2.85</u> in	Tare No.:	<u>T 18</u>
Length :	<u>2.80</u> in	Wet Wt.+tare:	<u>711.07</u>
Area :	<u>6.38</u> in ²	Dry Wt.+tare:	<u>478.92</u>
Volume :	<u>17.88</u> in ³	Tare Wt.:	<u>146.73</u>
Unit Wt.(wet):	<u>97.45</u> pcf	Dry Wt.:	<u>332.19</u>
Unit Wt.(dry):	<u>57.36</u> pcf	Water Wt.:	<u>232.15</u>
		% moist.:	<u>69.9</u>

Specific Gravity: 2.50 Max Dry Density(pcf) = 57.38916 OMC = 69.8847045
 % of max = 100.0 +/- OMC = 0.00
 Calculated % saturation: 87.92 Void ratio (e) = 1.72 Porosity (n) = 0.63

TEST READINGS

Z1(Mercury Height Difference @ t1): 5.1 cm Hydraulic Gradient = 9.04

Date	elapsed t (seconds)	Z (pipet @ t)	$\Delta Z\pi$ (cm)	temp (deg C)	α (temp corr)	k (cm/sec)	k (ft./day)	Reset = *
8/26/2009	80	4.2	2.4553335	25	0.889	3.20E-06	9.06E-03	
8/26/2009	90	4.05	2.6053335	25	0.889	3.10E-06	8.79E-03	
8/26/2009	100	3.9	2.7553335	25	0.889	3.04E-06	8.61E-03	
8/26/2009	110	3.75	2.9053335	25	0.889	3.00E-06	8.52E-03	

SUMMARY

ka = 3.08E-06 cm/sec Acceptance criteria = 25 %
 $\frac{k_i}{k_a}$
 k1 = 3.20E-06 cm/sec Vm = $\frac{k_a - k_i}{k_a} \times 100$ 3.6 %
 k2 = 3.10E-06 cm/sec 0.5 %
 k3 = 3.04E-06 cm/sec 1.5 %
 k4 = 3.00E-06 cm/sec 2.6 %

Hydraulic conductivity	k =	<u>3.08E-06</u> cm/sec	<u>8.74E-03</u> ft/day
Void Ratio	e =	<u>1.72</u>	
Porosity	n =	<u>0.63</u>	
Bulk Density	γ =	<u>1.56</u> g/cm3	<u>97.5</u> pcf
Water Content	W =	<u>0.64</u> cm3/cm3	(at 20 deg C)
Intrinsic Permeability	kint =	<u>3.16E-11</u> cm2	(at 20 deg C)

Liquid Limit LL		
Plastic Limit PL		
Plasticity Index PI		
- 200 Sieve		%
+ No 40 Sieve		%
+ No 4 Sieve		%

Respectfully Submitted

Robert M. Duke, P.E.

210 Beech Street
 Texarkana, AR 71854
 870-772-0013 Phone
 870-216-2413 Fax

1717 East Erwin
 Tyler, Texas 75702
 903-595-4421 Phone
 903-595-6113 Fax
 www.ettlinc.com

707 West Cotton Street
 Longview, Texas 75604-5505
 903-758-0915 Phone
 903-758-8245 Fax



ETTL Engineers & Consultants Inc.

GEOTECHNICAL * MATERIALS * ENVIRONMENTAL * DRILLING * LANDFILLS

HYDRAULIC CONDUCTIVITY DETERMINATION FLEXIBLE WALL PERMEAMETER - CONSTANT VOLUME (Mercury Permometer Test)

Project :	Luminant Martin Lake Supplemental, TP-31, Tatum, Texas							
Date:	9/9/2009	Panel Number :	P 1 ; ASTM D 5084					
Project No. :	G 3219-09	Permometer Data						
Boring No.:	TP- 31	ap =	0.031416 cm ²	Set Mercury to Dinat Dn at	Equilibrium	1.8	cm ³	
Sample:	9228	aa =	0.767120 cm ²		Pipet Rp	6.7	cm ³	
Depth (ft):	0' to 5'	M1 =	0.030180	C =	0.000414162	Annulus Ra	1.5	cm ³
Other Location:		M2 =	1.040953	T =	0.203870442			
Material Description :	Tan & Reddish Tan Silty Sand							

SAMPLE DATA

Wet Wt. sample + ring or tare :	627.20	g						
Tare or ring Wt. :	0.0	g						
Wet Wt. of Sample :	627.20	g						
Diameter :	2.89	in	7.33	cm ²	Before Test	After Test		
Length :	2.88	in	7.30	cm	Tare No.:	T 6	Tare No.:	T 1
Area:	6.55	in ²	42.23	cm ²	Wet Wt. +tare:	841.20	Wet Wt. +tare:	841.71
Volume :	18.82	in ³	308.41	cm ³	Dry Wt. +tare:	749.54	Dry Wt. +tare:	741.72
Unit Wt. (wet):	126.90	pcf	2.03	g/cm ³	Tare Wt.:	217.39	Tare Wt.:	217.29
Unit Wt. (dry):	108.26	pcf	1.73	g/cm ³	Dry Wt.:	532.15	Dry Wt.:	524.43
					Water Wt.:	91.66	Water Wt.:	99.99
					% moist.:	17.2	% moist.:	19.1

Specific Gravity:	2.65	Max Dry Density(pcf) =	108.3018	OMC =	17.2244668
		% of max =	100.0	+/- OMC =	0.00
Calculated % saturation:	95.65	Void ratio (e) =	0.53	Porosity (n)=	0.35

TEST READINGS

Z1(Mercury Height Difference @ t1):	5.1	cm	Hydraulic Gradient =	8.81				
Date	elapsed t	Z	$\Delta Z\pi$	temp	α	k	k	Reset = *
	(seconds)	(pipet @ t)	(cm)	(deg C)	(temp corr)	(cm/sec)	(ft./day)	
7/31/2009	600	5.3	1.3550759	25	0.889	1.98E-07	5.63E-04	
7/31/2009	720	5.1	1.5550759	25	0.889	1.95E-07	5.53E-04	
7/31/2009	840	5	1.6550759	25	0.889	1.80E-07	5.12E-04	
7/31/2009	960	4.8	1.8550759	25	0.889	1.82E-07	5.17E-04	

SUMMARY

ka =	1.89E-07	cm/sec	Acceptance criteria =	25 %
ki			Vm	
k1 =	1.98E-07	cm/sec	5.0	%
k2 =	1.95E-07	cm/sec	3.2	%
k3 =	1.80E-07	cm/sec	4.5	%
k4 =	1.82E-07	cm/sec	3.6	%
			Vm =	$\frac{ ka-ki }{ka} \times 100$

Hydraulic conductivity	k =	1.89E-07	cm/sec	5.36E-04	ft/day
Void Ratio	e =	0.53			
Porosity	n =	0.35			
Bulk Density	γ =	2.03	g/cm ³	126.9	pcf
Water Content	W =	0.30	cm ³ /cm ³	(at 20 deg C)	
Intrinsic Permeability	kint =	1.94E-12	cm ²	(at 20 deg C)	

Liquid Limit LL	20	
Plastic Limit PL	17	
Plasticity Index PI	3	
- 200 Sieve	27	%
+ No 40 Sieve	2	%
+ No 4 Sieve	1	%

Respectfully Submitted

Robert M. Duke, P.E.

210 Beech Street
Texarkana, AR 71854
870-772-0013 Phone
870-216-2413 Fax

1717 East Erwin
Tyler, Texas 75702
903-595-4421 Phone
903-595-6113 Fax
www.ettlinc.com

707 West Cotton Street
Longview, Texas 75604-5505
903-758-0915 Phone
903-758-8245 Fax

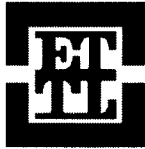

ETTL Engineers & Consultants Inc.

GEOTECHNICAL * MATERIALS * ENVIRONMENTAL * DRILLING * LANDFILLS

Project: Luminant Martin Lake Supplemental, Tatum, Texas
 Client: HDR
 Contractor: _____
 Job No. G 3219 - 09

Sample No.: 9228 Date Sampled: 8/26/2009
 Material Origin: TP- 31
 Sampling Info. provided By: Jacob LeNoir
 Location Sampled: TP- 31
 Material Description: Tan & Reddish Tan Silty Sand
 Sampled By: Jacob LeNoir
 Technician: T. Sliger Date: 8/28/2009

Maximum Dry Density: (ASTM D 698)	115.9	(lb/ft ³)
Optimum Moisture Content:	13.2	(%)

Classification

LL	20
PL	17
PI	3

-200 Sieve	27%
+40 Sieve	2%
+4 Sieve	1%

Proctor Points	
% Moisture	Dry Density (lb/ft ³)
9.6%	111.1
11.9%	114.9
14.3%	115.1
16.3%	110.9
18.6%	105.7

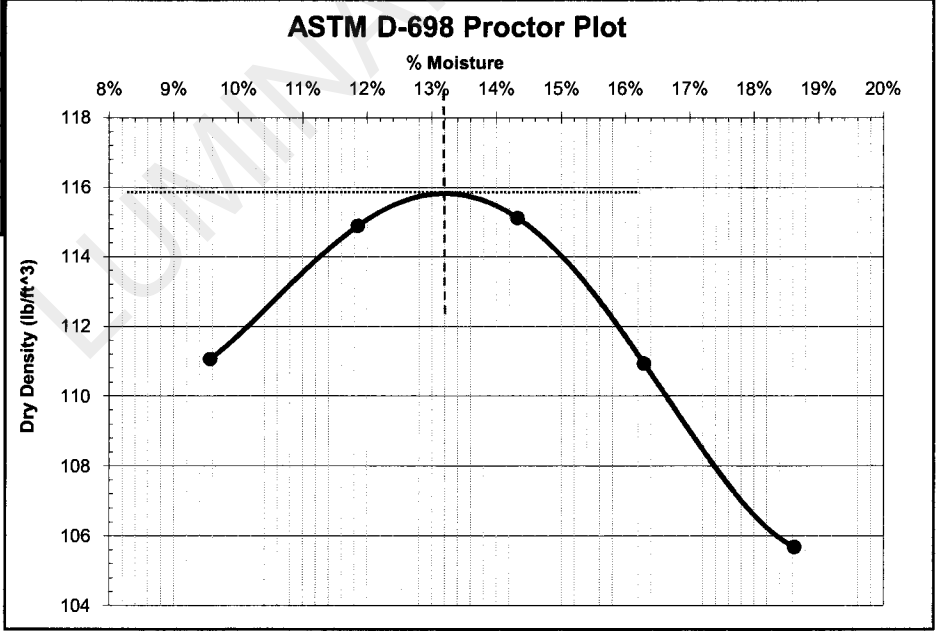

Respectfully Submitted

Robert M. Duke, P.E.

210 Beech Street
 Texarkana, AR 71854
 870-772-0013 Phone
 870-216-2413 Fax

1717 East Erwin
 Tyler, Texas 75702
 903-595-4421 Phone
 903-595-6113 Fax
 www.ettlinc.com

707 West Cotton Street
 Longview, Texas 75604-5505
 903-758-0915 Phone
 903-758-8245 Fax

Established in 1960, Golder Associates is a global, employee-owned organization that helps clients find sustainable solutions to the challenges of finite resources, energy and water supply and management, waste management, urbanization, and climate change. We provide a wide range of independent consulting, design, and construction services in our specialist areas of earth, environment, and energy. By building strong relationships and meeting the needs of clients, our people have created one of the most trusted professional services organizations in the world.

Africa	+ 27 11 254 4800
Asia	+ 852 2562 3658
Australasia	+ 61 3 8862 3500
Europe	+ 356 21 42 30 20
North America	+ 1 800 275 3281
South America	+ 56 2 2616 2000

solutions@golder.com
www.golder.com

Golder Associates Inc.
500 Century Plaza Drive, Suite 190
Houston, TX 77073 USA
Tel: (281) 821-6868
Fax: (281) 821-6870



Engineering Earth's Development, Preserving Earth's Integrity

Golder, Golder Associates and the GA globe design are trademarks of Golder Associates Corporation

APPENDIX F9 – SAFETY FACTOR ASSESSMENT



REPORT

SAFETY FACTOR ASSESSMENT REPORT

Martin Lake Steam Electric Station

Submitted To: Luminant
1601 Bryan Street
Dallas, TX 75201

Submitted By: Golder Associates Inc.
500 Century Plaza Drive, Suite 190
Houston, TX 77073 USA



Professional Engineering Firm
Registration Number F-2578

October 2016

Project No. 164816402





Table of Contents

1.0	INTRODUCTION.....	1
1.1	Purpose.....	1
1.2	Site Background.....	1
1.2.1	The Bottom Ash Ponds (BAPs).....	1
1.2.2	New Scrubber Pond (NSP).....	1
1.2.3	Permanent Disposal Pond-5 (PDP-5).....	2
1.3	Previous Slope Stability Evaluations.....	2
2.0	SUBSURFACE CONDITIONS.....	3
2.1	Site Geology.....	3
2.1.1	Bottom Ash Ponds and New Scrubber Pond.....	3
2.1.1.1	Subsurface Investigations and Laboratory Testing.....	3
2.1.1.2	Subsurface Site Conditions.....	4
2.1.2	Permanent Disposal Pond - 5.....	4
2.1.2.1	Subsurface Investigations and Laboratory Testing.....	4
2.1.2.2	Subsurface Site Conditions.....	5
3.0	STABILITY ANALYSIS - §257.73(e).....	6
3.1	Safety Factor Assessment.....	6
3.2	Cross-Sections Analyzed.....	6
3.2.1	Bottom Ash Ponds and New Scrubber Pond.....	6
3.2.2	Permanent Disposal Pond – 5.....	7
3.3	Material Properties.....	7
3.3.1	Bottom Ash Ponds and New Scrubber Pond – Cross Section A-A'.....	7
3.3.2	Permanent Disposal Pond – 5 – Cross Section B-B'.....	7
3.4	Phreatic Surface.....	8
3.4.1	Bottom Ash Ponds and New Scrubber Pond.....	8
3.4.2	Permanent Disposal Pond – 5.....	8
3.5	Seismic Loading.....	9
3.6	Liquefaction Potential.....	9
3.6.1	Bottom Ash Ponds and New Scrubber Pond.....	9
3.6.2	Permanent Disposal Pond - 5.....	9
3.7	Stability Analysis Results.....	10
4.0	CONCLUSION.....	12
5.0	CERTIFICATION.....	13
6.0	REFERENCES.....	14



List of Tables

Table 1	Soil Properties for Section A-A'
Table 2	Soil Properties for Section B-B'
Table 3	Slope Stability Analysis Results

List of Figures

Figure 1	General Site Map
----------	------------------

List of Appendices

Appendix A	Boring Location Map & Boring Logs
Appendix B	Laboratory Test Results
Appendix C	CPT-Based Liquefaction Potential Analysis
Appendix D	Slope Stability Analysis Results

LUMINANT



1.0 INTRODUCTION

1.1 Purpose

The “Disposal of Coal Combustion Residuals (CCR) from Electric Utilities rule” (40 Code of Federal Regulations (40 CFR) Part 257), effective October 19, 2015, requires that existing CCR surface impoundments meeting the requirements of §257.73(b) conduct initial and periodic safety factor assessments in accordance with §257.73(e). This report provides the safety factor assessments for the Martin Lake Steam Electric Station’s (MLSES’s) CCR Impoundments, identified as the Bottom Ash Ponds (BAPs) – the West Ash Pond (WAP) and the East Ash Pond (EAP) – the New Scrubber Pond (NSP), and the Permanent Disposal Pond-5 (PDP-5).

1.2 Site Background

The MLSES generates bottom ash, fly ash, and flue gas desulfurization (FGD) material during electricity generation. The following surface impoundments, shown on Figure 1, are in operation at the MLSES and subject to the CCR rule.

1.2.1 The Bottom Ash Ponds (BAPs)

The BAPs include the West Ash Pond (WAP) and the East Ash Pond (EAP). The WAP and EAP receive sluice water from bottom ash dewatering bins and other process wastewater sources that typically include bottom ash fines. The BAPs were originally constructed in 1977 with a 2-foot thick compacted clay liner. In 1989, the WAP was relined with a 60-mil high density polyethylene (HDPE) geomembrane over 3 feet of clay on the sideslopes, and the floor with a double 60-mil HDPE geomembrane with a geonet leak detection layer overlying an 18-inch thick clay liner. Both the sideslopes and floor are overlain with a 4-inch thick concrete revetment mat. In 2010, the sideslopes and floor of the EAP were relined with a double 60-mil HDPE geomembrane with a geonet leak detection layer overlying an 18-inch thick clay layer. A geotextile layer was placed between the lower geomembrane and the clay. The liner system on the sideslopes and floor of the EAP are overlain with a 4-inch thick concrete revetment mat.

1.2.2 New Scrubber Pond (NSP)

The NSP, abutting the southeastern portion of the WAP and the southern portion of the EAP, is used to manage FGD wastes and discharge from the sludge thickener sumps, the plant yard sumps, and stormwater management areas. Water collecting in the NSP serves as wet-well make-up water as well as emergency make-up water in the scrubber area. The NSP was originally constructed with the BAPs and lined with clay liner. In 1989, the NSP was relined with a double 60-mil HDPE geomembrane with a geonet leak detection layer. A geotextile layer was placed between the lower geomembrane and the subgrade and a 4-inch thick concrete revetment mat covers the upper geomembrane.



1.2.3 Permanent Disposal Pond-5 (PDP-5)

PDP-5 is primarily used to manage excess liquids including stormwater and excess process wastewater from both the New Scrubber Pond and Bottom Ash Ponds. Recovered CCR wastewaters are received in PDP-5 during cleaning cycles. PDP-5 was constructed in 2010/2011, above PDP-1, PDP-2, and PDP-3, which were previously closed as landfills. PDP-5 is lined with a 3-foot thick clay liner on the sideslopes and a 2-foot thick clay liner on the floor, both overlain with a 0.5-foot thick protective cover soil layer.

1.3 Previous Slope Stability Evaluations

Golder and ETTL Engineers and Consultants (ETTL) have previously performed evaluations on the BAPs, the NSP and PDP-5 as part of the following reports submitted to Luminant:

- Ash and Scrubber Ponds and Permanent Disposal Pond #4, Stability Investigation Report, Luminant Martin Lake SES, Rusk County, Texas, Golder, dated December 2012.
- Geotechnical Investigation, Luminant Martin Lake SES, Reline East Ash Disposal Pond, Tatum, Texas, ETTL, dated December 2008.

The studies found the BAPs and NSP slopes to be adequately stable.

ETTL performed stability evaluations on PDP-5 in 2009, as presented in the following report:

- Geotechnical Investigation, Luminant Martin Lake SES, Vertical Expansion of Permanent Disposal Ponds 1, 2, and 3, Tatum, Texas. ETTL Engineers and Consultants Inc. Tyler, Texas, dated July 2008.
- Geotechnical Investigation, Luminant Martin Lake SES, Vertical Expansion of Permanent Disposal Ponds 1, 2, and 3, Tatum, Texas – Supplemental Seepage and Slope Stability. ETTL Engineers and Consultants Inc., dated October 2009.

The above reports found the design slopes of PDP-5 to be stable as long as drainage is functional, preventing the embankments from saturating.



2.0 SUBSURFACE CONDITIONS

The MLSES site is located in the Martin Creek area which is situated in the Sabine River Valley and lies on the west flank of the Sabine Uplift. The formations in the region comprise sedimentary deposits of continental and marine origin, mainly the lower Wilcox Group flanked by younger beds like the Carrizo Sand. In the Martin Creek area, the Wilcox formation is estimated to be about 650- to 700-feet thick and consists of sandy clays, silty sands, clays, and lignite in varying amounts. The Rockdale formation is the major component in the area among the sediments of the Wilcox group occupying approximately the middle four-fifths of the Wilcox Section. The Wilcox Group is underlain by the Paleocene Midway Group (containing Upper Willis and Lower Kincaid), which is estimated to be 900-feet thick around the site, and is composed mainly of silty clay and clay. The Midway Group overlies a section of Cretaceous Rocks that are approximately 7000-feet thick (Rone Engineers, 1984).

2.1 Site Geology

2.1.1 Bottom Ash Ponds and New Scrubber Pond

2.1.1.1 Subsurface Investigations and Laboratory Testing

Information from previous subsurface investigations was used to characterize the subsurface site conditions. In 2008, E TTL conducted a subsurface investigation for the EAP as part of an effort to reline the pond. E TTL drilled twelve borings along the crest of the EAP embankment at approximate elevation 330 feet – mean sea level (ft-msl). All borings were 40-feet deep except one which was 100-feet deep. The boring map and boring logs are presented in Appendix A. Geotechnical laboratory testing – moisture contents, Atterberg limits, grain size distribution, and consolidated-undrained (CU) triaxial compression tests - was conducted on selected samples. The soil index testing results presented as part of the boring logs, while the CU test results from E TTL are summarized in Appendix B.

Golder conducted a subsurface investigation for the WAP and NSP in December 2012. Golder completed eight, 50- to 60-foot deep borings along the crest of the pond embankments at approximate elevation 330 ft-msl. The boring map and boring logs are presented in Appendix A. As part of the investigation, laboratory testing was performed on selected samples in accordance with commonly accepted methods and practices. Undisturbed and disturbed soil samples were tested to determine water content, Atterberg limits, grain size distribution, and shear strength. Water content determination was performed in accordance with ASTM D2216; Atterberg limits were determined in accordance with ASTM D4318; and grain size distribution was performed in accordance with ASTM D422. Shear strength testing consisted of unconsolidated-undrained (UU) triaxial compression in general accordance with ASTM D2850. Laboratory test results are presented in Appendix B.



The findings from the above subsurface investigations were reviewed for their applicability to this study, and are summarized in the following sections.

2.1.1.2 Subsurface Site Conditions

The above borings consisted of fill and native soils. The soils encountered in the borings generally consisted of stiff to hard sandy clays and firm to very dense sands. The subsurface stratigraphy generally consisted of interchanging layers of clays, sandy clays, clayey sands and non-plastic sands. The clayey sand layers ranged in thickness from 2 to 16 feet where encountered. The sandy clay and clay layers are described as firm to hard, low to high plasticity clays and vary in thickness from 2 to 38 feet. Loose to very dense, silty or poorly graded sand was typically encountered beneath or interlayered with the sandy clay/clayey sand strata. The 100-foot boring by ETTL showed deeper layers of very dense silty sand with intermittent layers of hard low plasticity clay.

Water was encountered in each of the eight borings performed by Golder, ranging between El. 296.1 to 303.3 ft-msl. The average water elevation measured in the Golder boreholes, during drilling, was at El. 300.3 ft-msl. The ETTL borings measured the water level to range between El. 304 to 309 ft-msl, with an average water level of El. 306 ft-msl.

Groundwater levels measured in 2015, from wells surrounding the BAPs vary from approximately El. 304 ft-msl in the southeast corner to El. 307 ft-msl in the northwest corner.

2.1.2 Permanent Disposal Pond - 5

2.1.2.1 Subsurface Investigations and Laboratory Testing

In 2008, ETTL performed a pre-construction subsurface investigation for PDP-5 that included a total of eleven borings within the PDP-5 footprint. In addition, three cone penetrometer tests (CPTs) were performed. As part of a supplemental investigation in 2009, ETTL drilled four additional borings within the pond footprint. A map of borings, and boring and CPT logs are presented in Appendix A.

ETTL performed laboratory tests including natural moisture contents (ASTM D2216), Atterberg limits (ASTM D4318), particle size distributions (ASTM D 1140 and ASTM D422). Unconsolidated-undrained (UU) triaxial compression tests (ASTM D2850) were performed to determine the strength characteristics of cohesive substrata. Direct shear tests (ASTM D3080) were performed on coarser materials including remolded bulk ash samples. Consolidation tests (ASTM D2435) and permeability tests (ASTM D5084) were also performed but are not relevant to the current study. The results of the laboratory tests performed by ETTL are presented in Appendix B.



2.1.2.2 Subsurface Site Conditions

Most of the above borings were drilled through the bottom ash within closed PDP-1, 2, and 3. Based on particle size, the ash classifies as very loose to medium dense poorly graded sands in some locations, to silts in other locations and depths. The borings passing through existing embankments of PDP-1, 2, and 3 contained medium stiff to very stiff clay of low plasticity and/or high plasticity clay with clayey sand. Native soils were identified in deeper borings as very dense silt with hard low plasticity clay seams.

Since the subsurface investigations for the PDP-5 area were performed prior to construction of the PDP-5 embankment, there are no borings that pass through the embankment. However, E TTL (E TTL 2009) identified a site borrow source (characterized as sandy materials), soils from which were to be used in the construction of the embankment. Triaxial strength testing (CU tests) were also performed on these site soils, and hence, the embankment strength has been estimated.

Two borings located outside of the ash encountered water approximately between El. 355 to 368 ft-msl. Groundwater levels measured in 2015, from wells surrounding PDP-5, indicate that the groundwater level varies from approximately El. 355 ft-msl in the north to El. 375 ft-msl in the south.

LUMINA



3.0 STABILITY ANALYSIS - §257.73(e)

3.1 Safety Factor Assessment

According to the CCR rules, structural stability factors of safety need to be evaluated for the critical cross-section of each CCR facility under static and seismic loading for “Maximum Storage Pool” (2 feet of freeboard for this facility) and “Maximum Surcharge Pool” (no freeboard) conditions. Liquefaction potential analysis is only necessary when soil sampling, construction documentation or anecdotal evidence from personnel with knowledge about the facility, indicates that soils of the embankment are susceptible to liquefaction. Since ash classifying as sandy soil is present below portions of the PDP-5 embankment, liquefaction potential is considered for PDP-5 foundation soils.

The safety factor assessment [§257.73(e)] does not require evaluation of rapid-drawdown loading conditions; however, if the CCR unit has downstream slopes that can be inundated by an adjacent water body, the structural stability assessment requirements [§257.73(d)(1)(viii)] state that these slopes must be assessed. Since one of the cross-sections analyzed in this Safety Factor Assessment may be subjected to rapid draw-drawdown conditions, this condition was evaluated and presented herein. The results of the analysis are also reported in the Structural Stability Assessment Report (Golder, 2016).

Slope stability analyses were performed using a limit-equilibrium-based commercial computer program, Slide v7.0 by Rocscience. The analyses used a searching routine to identify the potential failure surface with minimum factor of safety for a given set of geometry, ground and groundwater conditions. The Spencer method of analysis was used in the analyses, while the Morgenstern Price method was used for verification. The factors of safety of numerous potential failure surfaces were computed to establish minimum factors of safety. Circular failure surfaces were considered for all cases. Stability analyses were performed for “Maximum Storage Pool” (freeboard of 2 feet) and “Maximum Surcharge Pool” (no freeboard) conditions for both the interior and exterior slopes of the ponds. In addition, the interior slopes were analyzed while the pond is empty. For each case, respective slopes were analyzed for both static and seismic loading conditions. The interior berms separating individual ponds were not analyzed since the failure of the interior berms will not result in any release of CCR materials beyond the embankment surrounding the BAPs and NSP.

3.2 Cross-Sections Analyzed

3.2.1 Bottom Ash Ponds and New Scrubber Pond

The BAPs and NSP are contiguous ponds surrounded by a continuous embankment that was built using the same site soils. Hence, the embankment is considered as one structure and a critical cross-section was identified after considering multiple cross-sections across the entire embankment. The geometry of the slopes, soil profile, loading conditions, and phreatic surface of each segment of the embankment were



evaluated in identifying the critical cross-section. Cross-section (A-A'), located on the eastern slope of the EAP as shown on Figure 1, was identified as the critical cross-section for the BAPs and NSP and was selected for evaluation of factors of safety under the loading conditions identified in §257.74(e)(1)(i) - (iv).

3.2.2 Permanent Disposal Pond – 5

The geometry of the slopes, soil profile, loading conditions and phreatic surface of each segment of the embankment surrounding the PDP-5 was evaluated. Cross-Section B-B', located on the south side of PDP-5 as shown on Figure 1, was identified as the critical cross-section and was selected for evaluation of factors of safety under the loading conditions identified in §257.74(e)(1)(i) - (iv).

3.3 Material Properties

3.3.1 Bottom Ash Ponds and New Scrubber Pond – Cross Section A-A'

Based on the previous subsurface investigations, appropriate material properties were selected for use in the stability analysis. CU triaxial testing was performed on three samples on the BAP embankments, by ETTL (2008). The effective stress parameters from these three tests are averaged and used in the analysis. For the subsequent foundation soil layers, values of shear strength are chosen either based on testing of deeper samples by ETTL or by assuming typical, conservative values for sandy soils. Table 1 summarizes the material properties used in the stability analysis of Section A-A'.

Table 1: Soil Properties for Section A-A'

Soil Material	Description	Moist Unit Weight (lb/ft ³)	Saturated Unit Weight (lb/ft ³)	Drained Soil Properties	
				Cohesion, c' (lb/ft ²)	Friction Angle, ϕ' (°)
I	Fat Clay	120	125	542	23
II	Silty Sand	127	132	0	30
III	Clayey Sand	127	132	0	32
IV	Sand/Silty Sand	127	132	0	34

3.3.2 Permanent Disposal Pond – 5 – Cross Section B-B'

Based on the borings and CU tests performed as part of the 2009 investigation by ETTL, shear strength parameters were chosen for the soil layers for cross-section B-B'. For the deep sand layer, a conservative friction angle of 34° and zero cohesion was assumed. Table 2 summarizes the material properties used in the stability analysis of cross-section B-B'.

**Table 2: Soil Properties for Section B-B'**

Soil Material	Description	Moist Unit Weight (lb/ft ³)	Saturated Unit Weight (lb/ft ³)	Drained Soil Properties	
				Cohesion, c' (lb/ft ²)	Friction Angle, ϕ' (°)
I	New embankment	125	130	0	34.7
II	Clay liner	127	132	650	31.4
III	Old ash	90	95	0	34.6
IV	Native clay	127	132	175	31.9
V	Sandy Clay/Clayey Sand	127	132	650	31.4
VI	Deep sand	127	132	0	34

3.4 Phreatic Surface

3.4.1 Bottom Ash Ponds and New Scrubber Pond

For the purpose of this report, the phreatic surface is defined as the potential saturated zone within the embankment that could exist due to infiltration of water from the ponded CCR. As discussed earlier, measurements within the monitoring wells indicate groundwater levels across the BAPs and NSP vary between El. 304 to 307 ft-msl. At cross-section A-A', the groundwater level is assumed to be El. 306 ft-msl. The interior slopes of the ponds have a clay liner, a double HDPE geomembrane layer, overlain by a concrete revetment. Hence, it is unlikely that the phreatic surface will extend into the embankment, or into the ground below on the floor of the ponds.

Drawdown of the water level in Martin Lake can potentially affect the stability of Section A-A'. Based on the historic water level data available from the Texas Water Development Board (TWDB 2016), the maximum drawdown was observed to be about 10 feet. This drawdown, however, was not instant but spread across a period of approximately one year. Hence, effective stress-transient drawdown analyses were conducted for the exterior slope at Section A-A', for a 10-foot drawdown in water level at a uniform rate, over one year.

3.4.2 Permanent Disposal Pond – 5

As mentioned previously, groundwater levels measured in 2015, from wells surrounding PDP-5, indicate that the groundwater level around the pond varies from approximately El. 355 ft-msl in the north to El. 375 ft-msl in the south. Underlying PDP-5, the ash in PDP-1, 2 and 3 is at least partially saturated. A toe drain system keeps the water level within the ash below El. 380 feet. Therefore, the saturated zone within the ash is assumed to be at El. 380 ft-msl for cross-section B-B' on the upstream side.



For the stability analysis of the exterior embankment slope, the location of the phreatic surface is estimated by allowing steady state seepage conditions to develop based on the water level within PDP-5 and the elevation of the saturated ash in PDP-1, 2 and 3.

Note that the phreatic surface elevations were conservatively assumed for stability analysis purposes -- they do not represent the elevation of the uppermost aquifer.

3.5 Seismic Loading

Based on the "US Seismic Hazard 2014 Map" prepared by the United States Geologic Survey (USGS) and the "2008 Interactive Deaggregations" (USGS), the peak ground acceleration (PGA) for a 2% probability of exceedance in 50 years (return period of 2,475 years) is 0.09g for the site location (including amplification factors for site soil conditions). Hence, a horizontal seismic load coefficient of 0.09g was used in the pseudostatic analysis.

3.6 Liquefaction Potential

Soil liquefaction describes a phenomenon whereby a saturated or partially saturated soil substantially loses strength and stiffness in response to an applied stress, usually earthquake shaking or other sudden change in stress condition, causing it to behave like a liquid. The phenomenon is most often observed in saturated, loose (low density or uncompacted), sandy soils.

3.6.1 Bottom Ash Ponds and New Scrubber Pond

The embankment soils of the BAPs and NSP are composed of clayey materials with significant fines content. The immediate foundation materials are composed of sandy clay and compact to dense sand. The subsurface investigations do not indicate the presence of any soils in the embankment or its foundation that are susceptible to liquefaction. Hence, failure of the pond slopes due to liquefaction is considered unlikely for the BAPs and NSP.

3.6.2 Permanent Disposal Pond - 5

Based on particle size, the bottom ash within PDP-1, 2, and 3 classifies as very loose to medium dense, poorly graded sand at some locations and silts at other locations and depths. Therefore, portions of the foundation soils for PDP-5 embankments are founded above potentially liquefiable material. Based on the above mentioned E TTL reports and the preparation of foundation materials during construction, the foundations and abutments are generally considered to be stable. Nevertheless, due to the classification of the some of the underlying ash as poorly graded sand, the potential for cyclic liquefaction of the ash was evaluated.

As part of the 2008 investigation by E TTL, CPTs were conducted within the ash underlying PDP-5. Golder conducted a liquefaction analysis based on this CPT data using the commercially available program, CLiq



v.2.0.6.85 released by GeoLogismiki. The method prescribed by Robertson (2009) was adopted in the cyclic liquefaction analysis. The site earthquake information (magnitude and PGA) was estimated using the seismic hazard tool developed by USGS (USGS 2008).

The analysis showed that all three CPT locations showed a low likelihood for cyclic liquefaction with a factor of safety greater than the minimum factor of safety of 1.20 specified in §257.73(e)(iv). The results from the cyclic liquefaction analysis are presented in Appendix C.

3.7 Stability Analysis Results

Slope stability analyses were performed for long-term conditions for each of the critical cross-sections considered under static and seismic loading conditions. Both interior and exterior slopes were analyzed for “Maximum Storage Pool” (2 feet of freeboard) and “Maximum Surcharge Pool” (no freeboard) conditions. The interior slopes were analyzed for the condition where the pond is empty.

The results of the slope stability analyses cases are presented in Table 3 and Appendix D. The results indicate that the BAP, NSP, and PDP-5 pond slopes are sufficiently stable under all considered loading scenarios.



Table 3: Slope Stability Analysis Results

Pond(s)	Cross-Section	Case #	Slope Location	Pond Pool level	Loading Condition	Req'd Safety Factor ⁽¹⁾	Calculated Safety Factor
BAP and NSP	A-A'	1a	Exterior	Storage	Static	1.50	1.94
		1b			Pseudostatic	1.00	1.45
		1c			Rapid Drawdown	1.30 ⁽²⁾	1.61
		2a	Surcharge	Static	1.40	1.94	
		2b		Pseudostatic	1.00	1.45	
		3a	Interior	Storage	Static	1.50	6.43
		3b			Pseudostatic	1.00	4.22
		4a		Surcharge	Static	1.40	7.21
		4b			Pseudostatic	1.00	4.60
		5a		Empty	Static	1.50	2.54
5b	Pseudostatic	1.00	1.91				
PDP-5	B-B'	1a	Exterior	Storage	Static	1.50	1.67
		1b			Pseudostatic	1.00	1.13
		2a	Surcharge	Static	1.40	1.67	
		2b		Pseudostatic	1.00	1.13	
		3a	Interior	Storage	Static	1.50	2.05
		3b			Pseudostatic	1.00	1.31
		4a	Surcharge	Static	1.40	2.43	
		4b		Pseudostatic	1.00	1.45	
		5a	Empty	Static	1.50	2.31	
		5b		Pseudostatic	1.00	1.73	

Note: (1) Required safety factors per §257.73(e)(i)-(iii)
 (2) Required factor safety per EM 1110-2-1902 (USACE 2003)



4.0 CONCLUSION

Based on our review of the information provided by Luminant, on information prepared by Golder Associates Inc., and on our analyses, the calculated factors of safety through the critical cross sections in the surface impoundments exceed the values listed in §257.73(e)(1)(i)-(iv).

Golder appreciates the opportunity to assist Luminant with this project. If you have any questions, or require further assistance from Golder, please contact the undersigned at (281) 821-6868.

GOLDER ASSOCIATES INC.

A handwritten signature in black ink, appearing to read 'Varenya Kumar', located below the company name.

Varenya Kumar
Staff Engineer

VK/JBF

A handwritten signature in blue ink, appearing to read 'Jeffrey B. Fassett', located below the company name.

Jeffrey B. Fassett, PE
Associate Geotechnical Engineer

LUMINANT



5.0 CERTIFICATION

I hereby certify that this report has been prepared in general accordance with normally accepted civil engineering practices and in accordance with the requirements of 40 CFR 257.73(e).



Jeffrey B. Fassett, PE
Golder Associates Inc.
Firm Registration Number F-2578

LUMINANT



6.0 REFERENCES

- ETTL Engineers and Consultants Inc. 2008. Geotechnical Investigation, Luminant Martin Lake SES, Reline East Ash Disposal Pond, Tatum, Texas
- ETTL Engineers and Consultants Inc. 2008. Geotechnical Investigation, Luminant Martin Lake SES, Vertical Expansion of Permanent Disposal Ponds 1, 2, and 3, Tatum, Texas.
- ETTL Engineers and Consultants Inc. 2009. Geotechnical Investigation, Luminant Martin Lake SES, Vertical Expansion of Permanent Disposal Ponds 1, 2, and 3, Tatum, Texas – Supplemental Seepage.
- Golder Associates Inc. 2012. Ash and Scrubber Ponds and Permanent Disposal Pond #4 – Stability Investigation Report, Luminant Martin Lake Power Plant, Rusk County, Texas.
- Golder Associates Inc. 2016. Structural Stability Assessment Report, Luminant Martin Lake Steam Electric Station.
- Robertson, P.K. 2009. Performance based earthquake design using the CPT. In Proceedings of IS-Tokyo 2009: International Conference on Performance-Based Design in Earthquake Geotechnical Engineering — From Case History to Practice, Tokyo, Japan, 15–18 June 2009. Edited by T. Kokusho, Y. Tsukamoto, and M. Yoshimine. CRC Press/Balkema, Leiden, the Netherlands. pp. 3–20.
- Rone Engineers, 1984, Geotechnical Investigation, Solid Waste Disposal Facility No. 5, Martin Lake Steam Electric Station, Rusk County, Texas.
- Texas Water Development Board, 2016. Water data for Texas – Martin Lake Reservoir. (<http://www.waterdatafortexas.org/reservoirs/individual/martin>)
- United States Army Corps of Engineers, 2003. Slope Stability – Engineering Manual. EM 1110–2–1902.
- United States Department of Agriculture, Soil Conservation Service, 1990. Soil Survey of Camp, Franklin, Morris and Titus Counties, Texas.
- United States Geologic Survey, 2008. Interactive Deaggregations Tool. Geologic Hazards Science Center. (<http://geohazards.usgs.gov/deaggint/2008/>)



REFERENCE(S)
AERIAL PHOTO SOURCED FROM GOOGLE EARTH PRO DATED: 2015-10-01



Jeffrey B. Fassett
10/11/16



Professional Engineering Firm
Registration Number F-2578

0 600 1200
1" = 1200' FEET

CLIENT
LUMINANT POWER
MARTIN LAKE

PROJECT
2016 COAL COMBUSTION RESIDUALS
ENGINEERING SERVICES

CONSULTANT	YYYY-MM-DD	2016-09-22
	PREPARED	VK
	DESIGNED	TNB
	REVIEWED	MX
	APPROVED	JBF



TITLE
GENERAL SITE MAP

PROJECT NO.
164816402

REV.

FIGURE
1

APPENDIX A
BORING LOCATION MAP & BORING LOGS

BOTTOM ASH PONDS AND SCRUBBER POND

LUMIVANT

NOTE: Figure Reference - Golder Associates Inc. 2012. Ash and Scrubber Ponds and Permanent Disposal Pond #4 – Stability Investigation Report, Luminant Martin Lake Power Plant, Rusk County, Texas.



LEGEND

● BH-101 BORING LOCATION

REFERENCE

1.) AERIAL SHOWN LICENSED FROM GOOGLE EARTH PROFESSIONAL.

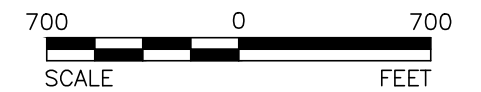

REV	DATE	DES	REVISION DESCRIPTION	CADD	CHK	RWW

PROJECT LUMINANT - MARTIN LAKE
ASH & SCRUBBER POND SLOPE STABILITY INVESTIGATION REPORT
RUSK COUNTY, TEXAS

TITLE

BORING LOCATIONS

		PROJECT No. 123-94128	FILE No. 12394128A003
DESIGN	MGP	12/04/12	SCALE AS SHOWN
CADD	RG	12/04/12	REV. 0
CHECK	MGP	12/04/12	FIGURE 1
REVIEW	PCM	12/04/12	

Drawing file: 12394128A003.dwg Dec 06, 2012 - 11:05am

© 2012 Google

Google™ earth



500 Century Plaza Drive, Suite 190
Houston, Texas 77073
Telephone: (281) 821-6868
Fax: (281) 821-6870

BORING NUMBER BH-201

CLIENT Luminant
PROJECT NUMBER 123-94128
DATE STARTED 10/28/12 **COMPLETED** 10/28/12
DRILLING CONTRACTOR WEST Drilling
DRILLING METHOD Hollow Stem Auger
LOGGED BY FW **CHECKED BY** MP
NOTES _____

PROJECT NAME Pond Slope Stability
PROJECT LOCATION Martin Lake
GROUND ELEVATION 330 ft **HOLE SIZE** 8 inches
GROUND WATER LEVELS:
▽ **AT TIME OF DRILLING** 28.30 ft / Elev 301.70 ft
AT END OF DRILLING ---
AFTER DRILLING ---

DEPTH (ft)	GRAPHIC LOG	MATERIAL DESCRIPTION	SAMPLE TYPE NUMBER	RECOVERY % (RQD)	BLOW COUNTS (N VALUE)	POCKET PEN. (tsf)	DRY UNIT WT. (pcf)	▲ SPT N VALUE ▲			
								PL	MC	LL	
								□ FINES CONTENT (%) □			
								20	40	60	80
0		Remove 8" sandy gravel as road base									
		(CL) SILTY CLAY, low plasticity, some sand, trace gravels, red, dry, hard	SH 1	44		5.0					
		(SC) CLAYEY SAND, non-plastic, some silt, tan and gray, dry, compact	SS 2	58	15-10-7 (17)						
5		(CL) SANDY CLAY, low plasticity, some silt, red, tan, and gray, mottled, dry, stiff	SH 3	44		3.5					
		(SC) CLAYEY SAND, fine, subangular, non-plastic, little silt, tan and gray, mottled, dry	SH 4	38		1.5					
10		(CL) SANDY CLAY, low plasticity, little silt and gravel, red, tan, and gray, mottled, dry, hard	SH 5	42		4.5					
15		some silt, no gravel, very stiff at 13.0'	SH 6	58		3.5					
20		some sand veins at 18.0'	SH 7	38		3.0					
25		gray, moist at 23.0'	SH 8	58		2.5					
30		▽ (SC) CLAYEY SAND, fine, subangular, low plasticity, some to little silt	SH 9	71		2.0					
35		some silt, tan and gray, mottled, moist at 33.0'	SS 10	100	9-7-9 (16)						

(Continued Next Page)

GEOTECH BH PLOTS - GINT STD US LAB.GDT - 12/4/12 15:58 - P.1 - 2012 PROJECT FOLDERS\123-94128 LUMINANT POND SLOPE STABILITY\MARTIN LAKE\LAB TESTING\94128\MARTINLAKE.GPJ



500 Century Plaza Drive, Suite 190
Houston, Texas 77073
Telephone: (281) 821-6868
Fax: (281) 821-6870

BORING NUMBER BH-201

CLIENT Luminant PROJECT NAME Pond Slope Stability
PROJECT NUMBER 123-94128 PROJECT LOCATION Martin Lake

DEPTH (ft)	GRAPHIC LOG	MATERIAL DESCRIPTION	SAMPLE TYPE NUMBER	RECOVERY % (RQD)	BLOW COUNTS (N VALUE)	POCKET PEN. (tsf)	DRY UNIT WT. (pcf)	▲ SPT N VALUE ▲			
								20	40	60	80
								PL	MC	LL	
								20	40	60	80
								□ FINES CONTENT (%) □			
								20	40	60	80
35											
40		some silty sand veins at 38.0'	SH 11	50		2.0					
45		(SM) SILTY SAND, fine, subangular, non-plastic, little clay, tan and red, wet, compact	SS 12	100	11-11-11 (22)						
		(SP) SAND, medium to fine, subangular, poorly graded, some silt, tan, wet, compact	SS 13	100	5-9-11 (20)						
50											

Bottom of borehole at 50.0 feet.

GEOTECH BH PLOTS - GINT STD US LAB.GDT - 12/4/12 15:58 - P.1_2012 PROJECT FOLDERS\123-94128 LUMINANT POND SLOPE STABILITY\MARTIN LAKE\LAB TESTING\94128\MARTINLAKE.GPJ

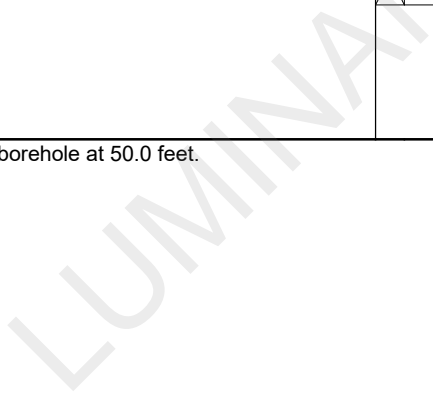



500 Century Plaza Drive, Suite 190
Houston, Texas 77073
Telephone: (281) 821-6868
Fax: (281) 821-6870

BORING NUMBER BH-202

PAGE 1 OF 2

CLIENT Luminant
PROJECT NUMBER 123-94128
DATE STARTED 10/29/12 **COMPLETED** 10/29/12
DRILLING CONTRACTOR WEST Drilling
DRILLING METHOD Hollow Stem Auger
LOGGED BY FW **CHECKED BY** MP
NOTES _____

PROJECT NAME Pond Slope Stability
PROJECT LOCATION Martin Lake
GROUND ELEVATION 330 ft **HOLE SIZE** 8 inches
GROUND WATER LEVELS:
▽ **AT TIME OF DRILLING** 26.70 ft / Elev 303.30 ft
AT END OF DRILLING ---
AFTER DRILLING ---

GEOTECH BH PLOTS - GINT STD US LAB.GDT - 12/4/12 15:58 - P.1 - 2012 PROJECT FOLDERS\123-94128 LUMINANT POND SLOPE STABILITY\MARTIN LAKE\LAB TESTING\94128\MARTINLAKE.GPJ

DEPTH (ft)	GRAPHIC LOG	MATERIAL DESCRIPTION	SAMPLE TYPE NUMBER	RECOVERY % (RQD)	BLOW COUNTS (N VALUE)	POCKET PEN. (tsf)	DRY UNIT WT. (pcf)	▲ SPT N VALUE ▲			
								PL	MC	LL	
								□ FINES CONTENT (%) □			
								20	40	60	80
0		Remove 6" sandy gravel from road bed									
0-2		(CH) CLAY, medium to high plasticity, some silt, trace fine sand, tan and gray, dry, very stiff to hard some sand at 2.0'	SH 1	50		4.5					
2-3			SH 2	63		3.5					
3-4			SH 3	50		5.0					
4-5			SH 4	63		3.75					
5-10		(CL) SANDY CLAY, low plasticity, some to little silt, tan and gray, mottled, moist, firm	SH 5	42		4.0					
10-13		some sand seams, very stiff at 13.0'									
13-14			SH 6	42		3.0					
14-20		(CL) SILTY CLAY, medium to high plasticity, little fine sand, brown, moist, firm	SH 7	58		1.0					
20-23		low plasticity, gray, moist at 23.0'									
23-24			SH 8	71		5.0					
24-30		▽									
30-32		(SM) SILTY SAND, fine, subangular, non-plastic, some clay, gray and tan, wet, compact	SS 9	83	7-7-9 (16)						
32-35		(SC) CLAYEY SAND, fine, subangular, low plasticity, some silt, tan and gray, wet, compact	SS 10	100	3-5-6 (11)						

(Continued Next Page)



500 Century Plaza Drive, Suite 190
Houston, Texas 77073
Telephone: (281) 821-6868
Fax: (281) 821-6870

BORING NUMBER BH-202

CLIENT Luminant PROJECT NAME Pond Slope Stability

PROJECT NUMBER 123-94128 PROJECT LOCATION Martin Lake

DEPTH (ft)	GRAPHIC LOG	MATERIAL DESCRIPTION	SAMPLE TYPE NUMBER	RECOVERY % (RQD)	BLOW COUNTS (N VALUE)	POCKET PEN. (tsf)	DRY UNIT WT. (pcf)	▲ SPT N VALUE ▲		
								20	40	60
								PL MC LL ----- ----- ----- 20 40 60 80		
								<input type="checkbox"/> FINES CONTENT (%) <input type="checkbox"/> 20 40 60 80		
35										
40		interbedded clay and sand seams at 38.0'	SS 11	100	8-7-8 (15)					
45		no seams at 43.0'	SS 12	89	4-4-4 (8)					
50		(SP) SAND, medium to fine, poorly graded, subangular, non-plastic, some silt and clay, wet, loose	SS 13	100	2-3-4 (7)					

Bottom of borehole at 50.0 feet.

GEOTECH BH PLOTS - GINT STD US LAB.GDT - 12/4/12 15:58 - P.1_2012 PROJECT FOLDERS\123-94128 LUMINANT POND SLOPE STABILITY\MARTIN LAKE\LAB TESTING\94128\MARTINLAKE.GPJ

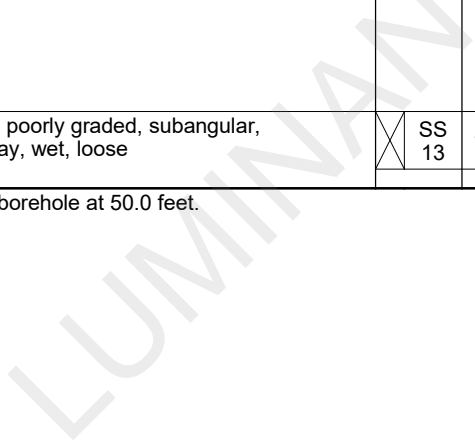



500 Century Plaza Drive, Suite 190
Houston, Texas 77073
Telephone: (281) 821-6868
Fax: (281) 821-6870

BORING NUMBER BH-203

PAGE 1 OF 2

CLIENT Luminant
PROJECT NUMBER 123-94128
DATE STARTED 10/30/12 **COMPLETED** 10/30/12
DRILLING CONTRACTOR WEST Drilling
DRILLING METHOD Hollow Stem Auger
LOGGED BY FW **CHECKED BY** MP
NOTES _____

PROJECT NAME Pond Slope Stability
PROJECT LOCATION Martin Lake
GROUND ELEVATION 330 ft **HOLE SIZE** 8 inches
GROUND WATER LEVELS:
▽ **AT TIME OF DRILLING** 28.80 ft / Elev 301.20 ft
AT END OF DRILLING ---
AFTER DRILLING ---

GEOTECH BH PLOTS - GINT STD US LAB.GDT - 12/4/12 15:58 - P.1 - 2012 PROJECT FOLDERS\123-94128 LUMINANT POND SLOPE STABILITY\MARTIN LAKE\LAB TESTING\94128\MARTINLAKE.GPJ

DEPTH (ft)	GRAPHIC LOG	MATERIAL DESCRIPTION	SAMPLE TYPE NUMBER	RECOVERY % (RQD)	BLOW COUNTS (N VALUE)	POCKET PEN. (tsf)	DRY UNIT WT. (pcf)	▲ SPT N VALUE ▲		
								PL	MC	LL
								□ FINES CONTENT (%) □		
0		remove 14" sandy GRAVEL as roadbed								
2.75		(CL) SILTY CLAY, low plasticity, little sand, gray and tan, mottled, dry, very stiff	SH 1	44		2.75				
5		(CL) SANDY CLAY, low plasticity, some silt, gray and tan, mottled, dry, stiff low plasticity, some sand veins, soft	SH 2	50		1.5				
5			SH 3	42		1.25				
10		(CL-CH) CLAY, low plasticity to medium plasticity, some silt, dark to light gray, dry, stiff very stiff at 8.0'	SH 4	67		1.75				
10			SH 5	50		3.25				
15		low plasticity, some silt and fine sand, little coarse sand and fine gravels, subrounded, red and tan, stiff at 13.0'	SH 6	38		1.5				
20		(CL) SANDY CLAY, low plasticity, some silt, tan and gray, mottled, dry, stiff	SH 7	44		2.0				
25		(SC) CLAYEY SAND, low plasticity, some silt, tan and gray, mottled, compact, moist	SS 8	94	3-7-7 (14)					
30	▽	low plasticity, with grey silty clay, some sand, tan at 28.0'	SS 9	94	4-7-8 (15)					
35		(SM) SILTY SAND, non-plastic, grading to sand, some silt, little to trace clay, gray, wet, compact	SS 10	100	3-8-9 (17)					

(Continued Next Page)



500 Century Plaza Drive, Suite 190
 Houston, Texas 77073
 Telephone: (281) 821-6868
 Fax: (281) 821-6870

BORING NUMBER BH-203

CLIENT Luminant PROJECT NAME Pond Slope Stability

PROJECT NUMBER 123-94128 PROJECT LOCATION Martin Lake

DEPTH (ft)	GRAPHIC LOG	MATERIAL DESCRIPTION	SAMPLE TYPE NUMBER	RECOVERY % (RQD)	BLOW COUNTS (N VALUE)	POCKET PEN. (tsf)	DRY UNIT WT. (pcf)	▲ SPT N VALUE ▲			
								PL	MC	LL	
								□ FINES CONTENT (%) □			
								20	40	60	80
35											
40		some clay and silt veins, tan at 38.0'	SS 11	100	3-6-6 (12)						
45		(SC) CLAYEY SAND, low plasticity, some silt, tan and brown, wet, compact	SS 12	100	4-8-10 (18)						
50		(SM) SILTY SAND, non-plastic, trace clay, tan and gray, wet, dense	SS 13	100	8-14-20 (34)						

Bottom of borehole at 50.0 feet.

GEOTECH BH PLOTS - GINT STD US LAB.GDT - 12/4/12 15:58 - P.1_2012 PROJECT FOLDERS\123-94128 LUMINANT POND SLOPE STABILITY\MARTIN LAKE\LAB TESTING\94128\MARTINLAKE.GPJ

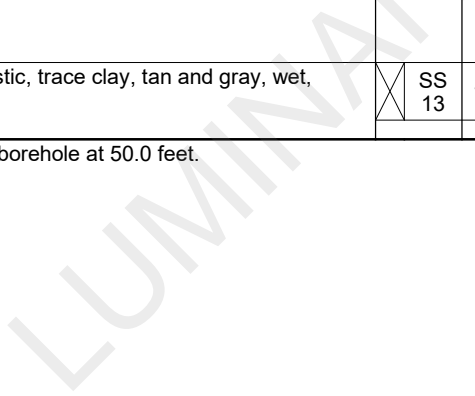



500 Century Plaza Drive, Suite 190
Houston, Texas 77073
Telephone: (281) 821-6868
Fax: (281) 821-6870

BORING NUMBER BH-204

CLIENT Luminant
PROJECT NUMBER 123-94128
DATE STARTED 10/30/12 **COMPLETED** 10/30/12
DRILLING CONTRACTOR WEST Drilling
DRILLING METHOD Hollow Stem Auger
LOGGED BY FW **CHECKED BY** MP
NOTES _____

PROJECT NAME Pond Slope Stability
PROJECT LOCATION Martin Lake
GROUND ELEVATION 330 ft **HOLE SIZE** 8 inches
GROUND WATER LEVELS:
▽ **AT TIME OF DRILLING** 31.80 ft / Elev 298.20 ft
AT END OF DRILLING ---
AFTER DRILLING ---

GEOTECH BH PLOTS - GINT STD US LAB.GDT - 12/4/12 15:58 - P.1 - 2012 PROJECT FOLDERS\123-94128 LUMINANT POND SLOPE STABILITY\MARTIN LAKE\LAB TESTING\94128\MARTINLAKE.GPJ

DEPTH (ft)	GRAPHIC LOG	MATERIAL DESCRIPTION	SAMPLE TYPE NUMBER	RECOVERY % (RQD)	BLOW COUNTS (N VALUE)	POCKET PEN. (tsf)	DRY UNIT WT. (pcf)	▲ SPT N VALUE ▲			
								PL	MC	LL	
								□ FINES CONTENT (%) □			
								20	40	60	80
0		removed SANDY GRAVEL from roadbed									
1		(CL) SILTY CLAY, low plasticity, some sand, tan and gray, mottled, dry, hard	SH 1	67		4.25		●			
2		(CL) LEAN CLAY, low plasticity, some silt, sand, and sand veins, red and gray, dry, very stiff	SH 2	50		3.0		●			
3		(SC) CLAYEY SAND, low plasticity, some silt and black sandy gravel veins, tan and gray, dry	SH 3	33		5.0		●			
4		(CL) SANDY CLAY, low plasticity, little silt, tan and gray, dry, stiff	SH 4	58		2.0		●			
5		(SC) CLAYEY SAND, non-plastic to low plasticity, little silty clay seam, tan, brown, with little gray, dry	SH 5	44		2.5		●			
10											
15		(CL) LEAN CLAY, low to medium plasticity, some silt, trace fine sand, tan, brown, and gray, mottled, dry, stiff	SH 6	67		2.0					
20		some sand, little silt	SH 7	67		1.5					
25		(CL) SANDY CLAY, low plasticity, little silt, tan and gray, moist, very stiff	SH 8	46		3.0					
30		(ML) SANDY SILT, low plasticity to non-plastic, fine, subangular, some clay, tan and gray, moist, soft	SS 9	100	2-1-3 (4)			▲ ● □			
31	▽	(SM) SILTY SAND, low plasticity to non-plastic, fine, subangular, gray with little brown, dense	SS 10	94	11-14-18 (32)			● ▲			
35											

(Continued Next Page)



500 Century Plaza Drive, Suite 190
Houston, Texas 77073
Telephone: (281) 821-6868
Fax: (281) 821-6870

BORING NUMBER BH-204

CLIENT Luminant PROJECT NAME Pond Slope Stability
PROJECT NUMBER 123-94128 PROJECT LOCATION Martin Lake

DEPTH (ft)	GRAPHIC LOG	MATERIAL DESCRIPTION	SAMPLE TYPE NUMBER	RECOVERY % (RQD)	BLOW COUNTS (N VALUE)	POCKET PEN. (tsf)	DRY UNIT WT. (pcf)	▲ SPT N VALUE ▲		
								20	40	60
								PL MC LL 20 40 60 80		
								<input type="checkbox"/> FINES CONTENT (%) <input type="checkbox"/> 20 40 60 80		
35										
40		(SC) CLAYEY SAND, fine, subangular, interbedded with gray, silty sand, some clay, tan, wet, compact	SS 11	94	4-5-6 (11)					
45		(CH) CLAY, medium plasticity, little silt, trace fine sand, gray, wet, stiff	SS 12	100	3-5-7 (12)					
50			SH 13	75		2.0				

Bottom of borehole at 50.0 feet.

GEOTECH BH PLOTS - GINT STD US LAB.GDT - 12/4/12 15:58 - P.1_2012 PROJECT FOLDERS\123-94128 LUMINANT POND SLOPE STABILITY\MARTIN LAKE\LAB TESTING\94128\MARTINLAKE.GPJ

LUMINANT



500 Century Plaza Drive, Suite 190
Houston, Texas 77073
Telephone: (281) 821-6868
Fax: (281) 821-6870

BORING NUMBER BH-205

PAGE 1 OF 2

CLIENT Luminant
PROJECT NUMBER 123-94128
DATE STARTED 10/30/12 **COMPLETED** 10/30/12
DRILLING CONTRACTOR WEST Drilling
DRILLING METHOD Hollow Stem Auger
LOGGED BY FW **CHECKED BY** MP
NOTES _____

PROJECT NAME Pond Slope Stability
PROJECT LOCATION Martin Lake
GROUND ELEVATION 330.5 ft **HOLE SIZE** 8 inches
GROUND WATER LEVELS:
▽ **AT TIME OF DRILLING** 29.40 ft / Elev 301.10 ft
AT END OF DRILLING ---
AFTER DRILLING ---

GEO TECH BH PLOTS - GINT STD US LAB.GDT - 12/4/12 15:58 - P.1 - 2012 PROJECT FOLDERS\123-94128 LUMINANT POND SLOPE STABILITY\MARTIN LAKE\LAB TESTING\94128\MARTINLAKE.GPJ

DEPTH (ft)	GRAPHIC LOG	MATERIAL DESCRIPTION	SAMPLE TYPE NUMBER	RECOVERY % (RQD)	BLOW COUNTS (N VALUE)	POCKET PEN. (tsf)	DRY UNIT WT. (pcf)	▲ SPT N VALUE ▲				
								20	40	60	80	
0		(CL) LEAN CLAY, medium plasticity, some silt, trace sand, tan and gray, mottled, dry, hard										
		with silty sand seams, very stiff at 2.0'	SH 1	50		4.0						
		stiff at 4.0'	SH 2	60		3.5						
5		very stiff at 6.0'	SH 3	40		1.25						
			SH 4	58		3.75						
			SH 5	44		3.5						
10		some to little silt at 13.0'										
			SH 6	42		3.0						
15		some clayey sand seams, stiff at 18.0'										
			SH 7	40		1.5						
20		(CL) SILTY CLAY, low plasticity, some sand, dark gray, moist, stiff										
			SH 8	67		1.75						
25		(CL) SANDY SILTY CLAY, low plasticity, little clay, light gray with little brown, moist, stiff										
			SS 9	67	2-5-7 (12)							
30		(CL) SANDY CLAY, low plasticity, some silt, tan and gray, moist, very stiff										
			SH 10	60		3.0						
35												

(Continued Next Page)



500 Century Plaza Drive, Suite 190
Houston, Texas 77073
Telephone: (281) 821-6868
Fax: (281) 821-6870

BORING NUMBER BH-205

PAGE 2 OF 2

CLIENT Luminant PROJECT NAME Pond Slope Stability

PROJECT NUMBER 123-94128 PROJECT LOCATION Martin Lake

DEPTH (ft)	GRAPHIC LOG	MATERIAL DESCRIPTION	SAMPLE TYPE NUMBER	RECOVERY % (RQD)	BLOW COUNTS (N VALUE)	POCKET PEN. (tsf)	DRY UNIT WT. (pcf)	▲ SPT N VALUE ▲	
								PL	MC LL
								□ FINES CONTENT (%) □	
								20	40 60 80
35									
40		(SC) CLAYEY SAND, interbedded with gray silty SAND, fine, subangular, little clay, compact, wet	SS 11	100	3-6-8 (14)			▲ ●	
45		(SP) SAND, fine, subangular, non-plastic, some clay, little silt, tan and brown, wet, compact	SS 12	100	4-9-12 (21)			▲ ●	
50		medium to fine, tan at 48.0'	SS 13	100	3-6-11 (17)			▲ ●	
55		very loose at 53.0'	SS 14	33				□ ●	
60		Bottom of borehole at 60.0 feet.							

GEOTECH BH PLOTS - GINT STD US LAB.GDT - 12/4/12 15:58 - P.1 - 2012 PROJECT FOLDERS\123-94128 LUMINANT POND SLOPE STABILITY\MARTIN LAKE\LAB TESTING\94128\MARTINLAKE.GPJ



500 Century Plaza Drive, Suite 190
Houston, Texas 77073
Telephone: (281) 821-6868
Fax: (281) 821-6870

BORING NUMBER BH-206

PAGE 1 OF 2

CLIENT Luminant
PROJECT NUMBER 123-94128
DATE STARTED 10/30/12 **COMPLETED** 10/30/12
DRILLING CONTRACTOR WEST Drilling
DRILLING METHOD Hollow Stem Auger
LOGGED BY FW **CHECKED BY** MP
NOTES _____

PROJECT NAME Pond Slope Stability
PROJECT LOCATION Martin Lake
GROUND ELEVATION 330.5 ft **HOLE SIZE** 8 inches
GROUND WATER LEVELS:
▽ **AT TIME OF DRILLING** 30.20 ft / Elev 300.30 ft
AT END OF DRILLING ---
AFTER DRILLING ---

DEPTH (ft)	GRAPHIC LOG	MATERIAL DESCRIPTION	SAMPLE TYPE NUMBER	RECOVERY % (RQD)	BLOW COUNTS (N VALUE)	POCKET PEN. (tsf)	DRY UNIT WT. (pcf)	▲ SPT N VALUE ▲			
								PL	MC	LL	
								□ FINES CONTENT (%) □			
								20	40	60	80
0		(CL) SANDY CLAY, low plasticity, some silt, tan and gray, mottled, dry, stiff	SH 1	44		2.25					
		decreased sand content, very stiff at 2.0'	SH 2	67		3.5					
5		interbedded with silty clay layers, very stiff at 4.0'	SH 3	50		2.25					
		some silty sand veins, very stiff at 6.0'	SH 4	67		3.5					
10			SH 5	52		3.5					
15		trace organics, hard at 13.0'	SH 6	54		4.5					
20		with clayey sand veins, hard at 18.0'	SH 7	50		5.0					
25		some red, moist at 23.0'	SH 8	50		4.5					
30		(CH) SANDY CLAY, medium to high plasticity, some silt, tan and gray, very stiff	SH 9	52		3.25					
35		increased sand and silt content, dark gray, stiff at 33.0'	SH 10	56		1.5					

(Continued Next Page)

GEO TECH BH PLOTS - GINT STD US LAB.GDT - 12/4/12 15:58 - P.1 - 2012 PROJECT FOLDERS\123-94128 LUMINANT POND SLOPE STABILITY\MARTIN LAKE\LAB TESTING\94128\MARTINLAKE.GPJ



CLIENT Luminant PROJECT NAME Pond Slope Stability
PROJECT NUMBER 123-94128 PROJECT LOCATION Martin Lake

DEPTH (ft)	GRAPHIC LOG	MATERIAL DESCRIPTION	SAMPLE TYPE NUMBER	RECOVERY % (RQD)	BLOW COUNTS (N VALUE)	POCKET PEN. (tsf)	DRY UNIT WT. (pcf)	▲ SPT N VALUE ▲	
								PL	MC LL
								□ FINES CONTENT (%) □	
								20	40 60 80
35									
40		(SC) CLAYEY SAND, fine, subangular, low plasticity, some to little silt, gray, tan, and red, mottled, wet, compact	SS 11	100	5-6-6 (12)			▲ ●	
45		(SM) SILTY SAND, fine, subangular, non-plastic, some clay, wet, loose	SS 12	100	3-4-5 (9)			▲ ●	
50		(SP) SAND, medium to fine, trace coarse, poorly graded, subangular, non-plastic, some silt, tan, wet, compact	SS 13	100	2-6-12 (18)			▲ ●	
55		no coarse, trace clay at 53.0'	SS 14	100	5-8-13 (21)			●	
60		dense at 58.0'	SS 15	100	9-18-23 (41)			● ▲	

Bottom of borehole at 60.0 feet.

GEOTECH BH PLOTS - GINT STD US LAB.GDT - 12/4/12 15:58 - P.1 - 2012 PROJECT FOLDERS\123-94128 LUMINANT POND SLOPE STABILITY\MARTIN LAKE\LAB TESTING\94128\MARTINLAKE.GPJ



500 Century Plaza Drive, Suite 190
Houston, Texas 77073
Telephone: (281) 821-6868
Fax: (281) 821-6870

BORING NUMBER BH-207

PAGE 1 OF 2

CLIENT Luminant
PROJECT NUMBER 123-94128
DATE STARTED 10/31/12 **COMPLETED** 10/31/12
DRILLING CONTRACTOR WEST Drilling
DRILLING METHOD Hollow Stem Auger
LOGGED BY FW **CHECKED BY** MP
NOTES _____

PROJECT NAME Pond Slope Stability
PROJECT LOCATION Martin Lake
GROUND ELEVATION 330.5 ft **HOLE SIZE** 8 inches
GROUND WATER LEVELS:
▽ **AT TIME OF DRILLING** 34.40 ft / Elev 296.10 ft
AT END OF DRILLING ---
AFTER DRILLING ---

GEOTECH BH PLOTS - GINT STD US LAB.GDT - 12/4/12 15:58 - P.1 - 2012 PROJECT FOLDERS\123-94128 LUMINANT POND SLOPE STABILITY\MARTIN LAKE\LAB TESTING\94128\MARTINLAKE.GPJ

DEPTH (ft)	GRAPHIC LOG	MATERIAL DESCRIPTION	SAMPLE TYPE NUMBER	RECOVERY % (RQD)	BLOW COUNTS (N VALUE)	POCKET PEN. (tsf)	DRY UNIT WT. (pcf)	▲ SPT N VALUE ▲			
								PL	MC	LL	
								□ FINES CONTENT (%) □			
								20	40	60	80
0		remove 8" of SANDY GRAVEL from roadbed									
0-1		(CL) SILTY CLAY, low plasticity, trace fine sand, gray, dry, hard	SH 1	33		5.0		●			
1-4		(CL) SANDY CLAY, low plasticity, some silt and interbedded sand seams, tan and gray, mottled, dry, firm	SH 2	58		3.0		●			
4-5		(SP) SAND, poorly graded, non-plastic, some silt, clay, and gravel, black and tan, dry	SH 3	38		0.0		●			
5-8		(CL) SANDY CLAY, low plasticity, some silt, gray and tan, dry, firm	SH 4	54		3.0		●			
8-10		hard at 8.0'	SH 5	50		5.0					
10-13		decrease sand content, stiff at 13.0'	SH 6	56		3.75		●			
13-18		some sand seams at 18.0'	SH 7	52		2.5		●			
18-25		(SM) SILTY SAND, non-plastic, fine, subangular, little clay, gray, moist	SH 8	33				●			
25-30		(CL) SILTY CLAY, non-plastic, some sand, gray, moist, hard	SH 9	60		5.0		●	—		
30-35		(SM) SILTY SAND, non-plastic, fine, subangular, little clay, gray with little tan, moist, compact	SS 10	89	6-7-7 (14)			●			

(Continued Next Page)



CLIENT Luminant PROJECT NAME Pond Slope Stability
PROJECT NUMBER 123-94128 PROJECT LOCATION Martin Lake

DEPTH (ft)	GRAPHIC LOG	MATERIAL DESCRIPTION	SAMPLE TYPE NUMBER	RECOVERY % (RQD)	BLOW COUNTS (N VALUE)	POCKET PEN. (tsf)	DRY UNIT WT. (pcf)	▲ SPT N VALUE ▲	
								PL	MC LL
								□ FINES CONTENT (%) □	
								20	40 60 80
35									
40		(SC) CLAYEY SAND, non-plastic, fine, subangular, some silt, gray and tan, wet, loose	SS 11	67	2-3-4 (7)				
45		compact at 43.0'	SS 12	100	3-5-5 (10)				
50			SS 13	100	3-5-6 (11)				
55		(SP) SAND, medium to fine, non-plastic, some silt and clay, gray and tan, wet, loose	SS 14	89	2-2-5 (7)				
60		(CL) SILTY CLAY, low plasticity, trace fine sand, gray, wet, very stiff	SS 15	100	3-7-12 (19)				

Bottom of borehole at 60.0 feet.

GEOTECH BH PLOTS - GINT STD US LAB.GDT - 12/4/12 15:58 - P.1 - 2012 PROJECT FOLDERS\123-94128 LUMINANT POND SLOPE STABILITY\MARTIN LAKE\LAB TESTING\94128\MARTINLAKE.GPJ



500 Century Plaza Drive, Suite 190
Houston, Texas 77073
Telephone: (281) 821-6868
Fax: (281) 821-6870

BORING NUMBER BH-208

PAGE 1 OF 2

CLIENT Luminant
PROJECT NUMBER 123-94128
DATE STARTED 10/31/12 **COMPLETED** 10/31/12
DRILLING CONTRACTOR WEST Drilling
DRILLING METHOD Hollow Stem Auger
LOGGED BY FW **CHECKED BY** MP
NOTES _____

PROJECT NAME Pond Slope Stability
PROJECT LOCATION Martin Lake
GROUND ELEVATION 330.5 ft **HOLE SIZE** 8 inches
GROUND WATER LEVELS:
▽ **AT TIME OF DRILLING** 30.00 ft / Elev 300.50 ft
AT END OF DRILLING ---
AFTER DRILLING ---

DEPTH (ft)	GRAPHIC LOG	MATERIAL DESCRIPTION	SAMPLE TYPE NUMBER	RECOVERY % (RQD)	BLOW COUNTS (N VALUE)	POCKET PEN. (tsf)	DRY UNIT WT. (pcf)	▲ SPT N VALUE ▲				
								20	40	60	80	
0		remove 12" of SANDY GRAVEL from roadbed										
0 - 2.0		(CL) SANDY CLAY, low plasticity, some silt, tan and gray, dry, stiff to very stiff at 2.0'	SH 1	44		3.5						
2.0 - 4.0		hard at 4.0'	SH 2	50		4.0						
4.0 - 5.0			SH 3	54		5.0						
5.0 - 10.0		SILTY SAND, nonplastic, some clay, dry	SH 4	31		1.5						
10.0 - 15.0		(CL) SANDY CLAY, low plasticity, some silt, tan, gray, and red, dry, soft to firm	SH 5	50		2.0						
15.0 - 18.0			SH 6	40		2.5						
18.0 - 23.0		very stiff at 18.0'	SH 7	50		3.5						
23.0 - 28.0		hard at 23.0'	SH 8	46		5.0						
28.0 - 30.0		some sand seams, moist, very stiff at 28.0'	SH 9	54		3.0						
30.0 - 35.0		(SC) CLAYEY SAND, fine, subangular, some silt, tan, gray, and red, moist	SH 10	60		2.5						

GEOTECH BH PLOTS - GINT STD US LAB.GDT - 12/4/12 15:58 - P.1 - 2012 PROJECT FOLDERS\123-94128 LUMINANT POND SLOPE STABILITY\MARTIN LAKE\LAB TESTING\94128\MARTINLAKE.GPJ

(Continued Next Page)



CLIENT Luminant PROJECT NAME Pond Slope Stability

PROJECT NUMBER 123-94128 PROJECT LOCATION Martin Lake

DEPTH (ft)	GRAPHIC LOG	MATERIAL DESCRIPTION	SAMPLE TYPE NUMBER	RECOVERY % (RQD)	BLOW COUNTS (N VALUE)	POCKET PEN. (tsf)	DRY UNIT WT. (pcf)	▲ SPT N VALUE ▲	
								PL	MC LL
								□ FINES CONTENT (%) □	
								20	40 60 80
35									
40		wet at 38.0'	SH 11	50					
45		loose at 43.0'	SS 12	100	3-2-3 (5)				
50		(SP) SAND, fine, little medium, non-plastic, subangular, little clay, tan, compact	SS 13	72	1-6-8 (14)				
55		(SC) CLAYEY SAND, medium, some silt, brown (SM) SILTY SAND, fine, subangular, non-plastic, little clay, gray, compact	SS 14	100	3-6-7 (13)				
60		(CL) SILTY CLAY, low plasticity, dark gray, dense SANDY GRAVEL, non-plastic, planar, lignite coal seam, black, hard	SS 15	100	7-43-50 (93)				

Bottom of borehole at 60.0 feet.

GEOTECH BH PLOTS - GINT STD US LAB.GDT - 12/4/12 15:58 - P.1 - 2012 PROJECT FOLDERS\123-94128 LUMINANT POND SLOPE STABILITY\MARTIN LAKE\LAB TESTING\94128\MARTINLAKE.GPJ



500 Century Plaza Drive, Suite 190
Houston, Texas 77073
Telephone: (281) 821-6868
Fax: (281) 821-6870

BORING NUMBER BH-209

PAGE 1 OF 2

CLIENT Luminant
PROJECT NUMBER 123-94128
DATE STARTED 11/1/12 **COMPLETED** 11/1/12
DRILLING CONTRACTOR WEST Drilling
DRILLING METHOD Hollow Stem Auger
LOGGED BY FW **CHECKED BY** MP
NOTES _____

PROJECT NAME Pond Slope Stability
PROJECT LOCATION Martin Lake
GROUND ELEVATION 360 ft **HOLE SIZE** 8 inches
GROUND WATER LEVELS:
▽ **AT TIME OF DRILLING** 46.20 ft / Elev 313.80 ft no reading, cave in at 46
AT END OF DRILLING ---
AFTER DRILLING ---

DEPTH (ft)	GRAPHIC LOG	MATERIAL DESCRIPTION	SAMPLE TYPE NUMBER	RECOVERY % (RQD)	BLOW COUNTS (N VALUE)	POCKET PEN. (tsf)	DRY UNIT WT. (pcf)	▲ SPT N VALUE ▲		
								20	40	60
								PL MC LL 20 40 60 80		
								<input type="checkbox"/> FINES CONTENT (%) <input type="checkbox"/> 20 40 60 80		
0		(SC) CLAYEY SAND, fine, subangular, medium plasticity, some fine rounded gravel, red and brown, dry	SH 1	33		5.0		●		
		trace fine rounded gravel, tan and gray, mottled at 2.0'	SH 2	38		5.0		●		
5		little silt, no gravel at 4.0'	SH 3	38		5.0		●	—	—
		some silt at 6.0'	SH 4	29		4.5		●		
10		(CL) SANDY CLAY, low plasticity, some silt, tan and gray, dry, firm	SS 5	33	2-2-5 (7)			▲ ●		
		some red, hard at 13.0'	SH 6	21		5.0		●		
20		gray, moist, very stiff at 18.0'	SH 7	29		2.5		●		
25		(CL) LEAN CLAY, low plasticity, some silt, trace fine sand, gray and tan, moist, stiff	SS 8	67	4-6-8 (14)			▲		
		little silt, hard, gray at 28.0'	SH 9	50		5.0		●	—	—
35		grading to clayey sand, very stiff at 33.0'	SH 10	42		3.0		●		

(Continued Next Page)

GEOTECH BH PLOTS - GINT STD US LAB.GDT - 12/4/12 15:58 - P.1 - 2012 PROJECT FOLDERS\123-94128 LUMINANT POND SLOPE STABILITY\MARTIN LAKE\LAB TESTING\94128\MARTINLAKE.GPJ



500 Century Plaza Drive, Suite 190
Houston, Texas 77073
Telephone: (281) 821-6868
Fax: (281) 821-6870

BORING NUMBER BH-209

CLIENT Luminant PROJECT NAME Pond Slope Stability
PROJECT NUMBER 123-94128 PROJECT LOCATION Martin Lake

DEPTH (ft)	GRAPHIC LOG	MATERIAL DESCRIPTION	SAMPLE TYPE NUMBER	RECOVERY % (RQD)	BLOW COUNTS (N VALUE)	POCKET PEN. (tsf)	DRY UNIT WT. (pcf)	▲ SPT N VALUE ▲			
								20	40	60	80
								PL	MC	LL	
								20	40	60	80
								□ FINES CONTENT (%) □			
								20	40	60	80
35											
40		some silt and sand, gray, tan, and brown, hard at 38.0'	SS 11	100	7-13-14 (27)						
45		(CL) SILTY CLAY, low plasticity, dark gray, moist, hard	SS 12	100	12-20-26 (46)						
50		(SM) SILTY SAND, fine, subangular, non-plastic, some clay, tan and gray, moist, very dense	SS 13	100	14-27-36 (63)						

Bottom of borehole at 50.0 feet.

GEOTECH BH PLOTS - GINT STD US LAB.GDT - 12/4/12 15:58 - P.1 - 2012 PROJECT FOLDERS\123-94128 LUMINANT POND SLOPE STABILITY\MARTIN LAKE\LAB TESTING\94128\MARTINLAKE.GPJ

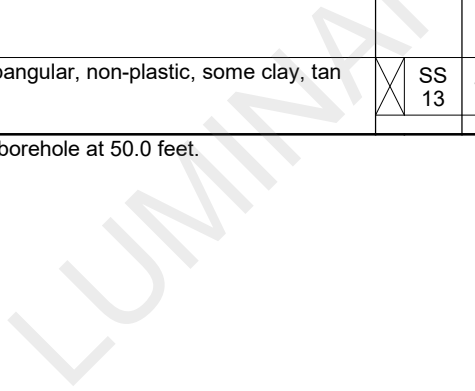



500 Century Plaza Drive, Suite 190
Houston, Texas 77073
Telephone: (281) 821-6868
Fax: (281) 821-6870

BORING NUMBER BH-210

PAGE 1 OF 2

CLIENT Luminant
PROJECT NUMBER 123-94128
DATE STARTED 11/1/12 **COMPLETED** 11/1/12
DRILLING CONTRACTOR WEST Drilling
DRILLING METHOD Hollow Stem Auger
LOGGED BY FW **CHECKED BY** MP
NOTES _____

PROJECT NAME Pond Slope Stability
PROJECT LOCATION Martin Lake
GROUND ELEVATION 360 ft **HOLE SIZE** 8 inches
GROUND WATER LEVELS:
▽ **AT TIME OF DRILLING** 47.00 ft / Elev 313.00 ft no reading, cave in at 47
AT END OF DRILLING ---
AFTER DRILLING ---

GEOTECH BH PLOTS - GINT STD US LAB.GDT - 12/4/12 15:58 - P.1 - 2012 PROJECT FOLDERS\123-94128 LUMINANT POND SLOPE STABILITY\MARTIN LAKE\LAB TESTING\94128\MARTINLAKE.GPJ

DEPTH (ft)	GRAPHIC LOG	MATERIAL DESCRIPTION	SAMPLE TYPE NUMBER	RECOVERY % (RQD)	BLOW COUNTS (N VALUE)	POCKET PEN. (tsf)	DRY UNIT WT. (pcf)	▲ SPT N VALUE ▲		
								20	40	60
0										
0 - 5		(SC) CLAYEY SAND, fine, subangular, some silt, little fine rounded gravel, red, dry trace roots at 1.0' tan, gray, and red, mottled at 2.0' compact at 4.0'	SH 1	25		5.0				
			SH 2	21		5.0				
5			SS 3	67	4-7-10 (17)					
			SS 4	39	3-6-6 (12)					
			SS 5	33	3-4-6 (10)					
15		(CL) SANDY CLAY, low to medium plasticity, little silt, red and gray, dry, very stiff	SH 6	21		3.0				
20		some silt and sand seams, gray and tan, moist, very stiff at 18.0'	SH 7	89		3.5				
25		little red, hard at 23.0'	SH 8	50		4.5				
30		trace subrounded fine gravels and coarse sand at 28.0'	SH 9	29		4.0				
35		(SC) CLAYEY SAND, fine, subangular, some silt, brown and tan, moist	SH 10	35		4.0				

(Continued Next Page)



CLIENT Luminant

PROJECT NAME Pond Slope Stability

PROJECT NUMBER 123-94128

PROJECT LOCATION Martin Lake

DEPTH (ft)	GRAPHIC LOG	MATERIAL DESCRIPTION	SAMPLE TYPE NUMBER	RECOVERY % (RQD)	BLOW COUNTS (N VALUE)	POCKET PEN. (tsf)	DRY UNIT WT. (pcf)	▲ SPT N VALUE ▲		
								20	40	60
								PL MC LL 20 40 60 80		
								<input type="checkbox"/> FINES CONTENT (%) <input type="checkbox"/> 20 40 60 80		
35										
40		(SM) SILTY SAND, fine, subangular, non-plastic, little clay, dark gray, moist, compact	SS 11	50	4-5-5 (10)					
45		(CL) SILTY CLAY, low plasticity, little fine sand, gray, moist, stiff	SS 12	94	2-4-5 (9)					
50		(SM) SILTY SAND, fine, subangular, non-plastic, some clay, gray and tan, mottled, wet, compact	SS 13	100	4-7-8 (15)					
55			SS 14	89	5-9-9 (18)					
60		little tan, dense at 58.0'	SS 15	100	7-14-17 (31)					
65			SS 16	100	11-15-19 (34)					
70		some dark brown clay seams at 68.0'	SS 17	100	10-15-25 (40)					

Bottom of borehole at 70.0 feet.

GEOTECH BH PLOTS - GINT STD US LAB.GDT - 12/4/12 15:58 - P.1 - 2012 PROJECT FOLDERS\123-94128 LUMINANT POND SLOPE STABILITY\MARTIN LAKE\LAB TESTING\94128\MARTINLAKE.GPJ



500 Century Plaza Drive, Suite 190
Houston, Texas 77073
Telephone: (281) 821-6868
Fax: (281) 821-6870

BORING NUMBER BH-211

PAGE 1 OF 2

CLIENT Luminant
PROJECT NUMBER 123-94128
DATE STARTED 11/2/12 **COMPLETED** 11/2/12
DRILLING CONTRACTOR WEST Drilling
DRILLING METHOD Hollow Stem Auger
LOGGED BY FW **CHECKED BY** MP
NOTES _____

PROJECT NAME Pond Slope Stability
PROJECT LOCATION Martin Lake
GROUND ELEVATION 360 ft **HOLE SIZE** 8 inches
GROUND WATER LEVELS:
▽ **AT TIME OF DRILLING** 60.20 ft / Elev 299.80 ft no reading, cave in at 60
AT END OF DRILLING ---
AFTER DRILLING ---

DEPTH (ft)	GRAPHIC LOG	MATERIAL DESCRIPTION	SAMPLE TYPE NUMBER	RECOVERY % (RQD)	BLOW COUNTS (N VALUE)	POCKET PEN. (tsf)	DRY UNIT WT. (pcf)	▲ SPT N VALUE ▲		
								20	40	60
								PL MC LL 20 40 60 80		
								<input type="checkbox"/> FINES CONTENT (%) <input type="checkbox"/> 20 40 60 80		
0		(SC) CLAYEY SAND, some silt and fine rounded gravel, red, dry								
		fine, subangular, gray, tan, and red at 2.0'	SH 1	29		5.0				
		trace fine gravels and coarse sand, loose at 4.0'	SH 2	29		3.5				
5		some sandy clay seams, compact at 6.0'	SS 3	50	2-3-6 (9)					
		increase clay and silt content at 8.0'	SS 4	39	4-5-8 (13)					
10			SS 5	72	4-8-8 (16)					
15		(CL-CH) SANDY CLAY, low to medium plasticity, little silt, gray, tan, and red, dry, stiff	SS 6	33	2-5-6 (11)					
		some silt at 18.0'	SH 7	50		3.25				
20		brown and tan at 23.0'	SH 8	44		5.0				
25			SH 9	25						
30		(ML) SANDY SILT, little clay, tan, moist								
35		(SM) SILTY SAND, fine, subangular, some clay, tan and gray, dense	SS 10	67	7-15-19 (34)					

(Continued Next Page)

GEOTECH BH PLOTS - GINT STD US LAB.GDT - 12/4/12 15:58 - P.1 - 2012 PROJECT FOLDERS\123-94128 LUMINANT POND SLOPE STABILITY\MARTIN LAKE\LAB TESTING\94128\MARTINLAKE.GPJ



CLIENT Luminant PROJECT NAME Pond Slope Stability
PROJECT NUMBER 123-94128 PROJECT LOCATION Martin Lake

DEPTH (ft)	GRAPHIC LOG	MATERIAL DESCRIPTION	SAMPLE TYPE NUMBER	RECOVERY % (RQD)	BLOW COUNTS (N VALUE)	POCKET PEN. (tsf)	DRY UNIT WT. (pcf)	▲ SPT N VALUE ▲		
								20	40	60
								PL MC LL 20 40 60 80		
								<input type="checkbox"/> FINES CONTENT (%) <input type="checkbox"/> 20 40 60 80		
35										
40			SS 11	89	9-17-25 (42)					
45			SS 12	100	10-14-18 (32)					
50		(SC) CLAYEY SAND, low plasticity, fine, subangular, some silt and lean clay, gray and tan, wet, dense	SS 13	89	9-14-18 (32)					
55		(SP) SAND, fine, subangular, non-plastic, some silt, little to trace clay, tan, wet, very dense	SS 14	100	17-29-38 (67)					
60		little medium at 58.0'	SS 15	78	14-28-33 (61)					
65			SS 16	100	17-29-34 (63)					
70		(SM) SILTY SAND, fine, subangular, non-plastic, little to trace clay, gray and tan, wet, very dense	SS 17	72	18-27-37 (64)					

Bottom of borehole at 70.0 feet.

GEOTECH BH PLOTS - GINT STD US LAB.GDT - 12/4/12 15:58 - P.1 - 2012 PROJECT FOLDERS\123-94128 LUMINANT POND SLOPE STABILITY\MARTIN LAKE\LAB TESTING\94128\MARTINLAKE.GPJ

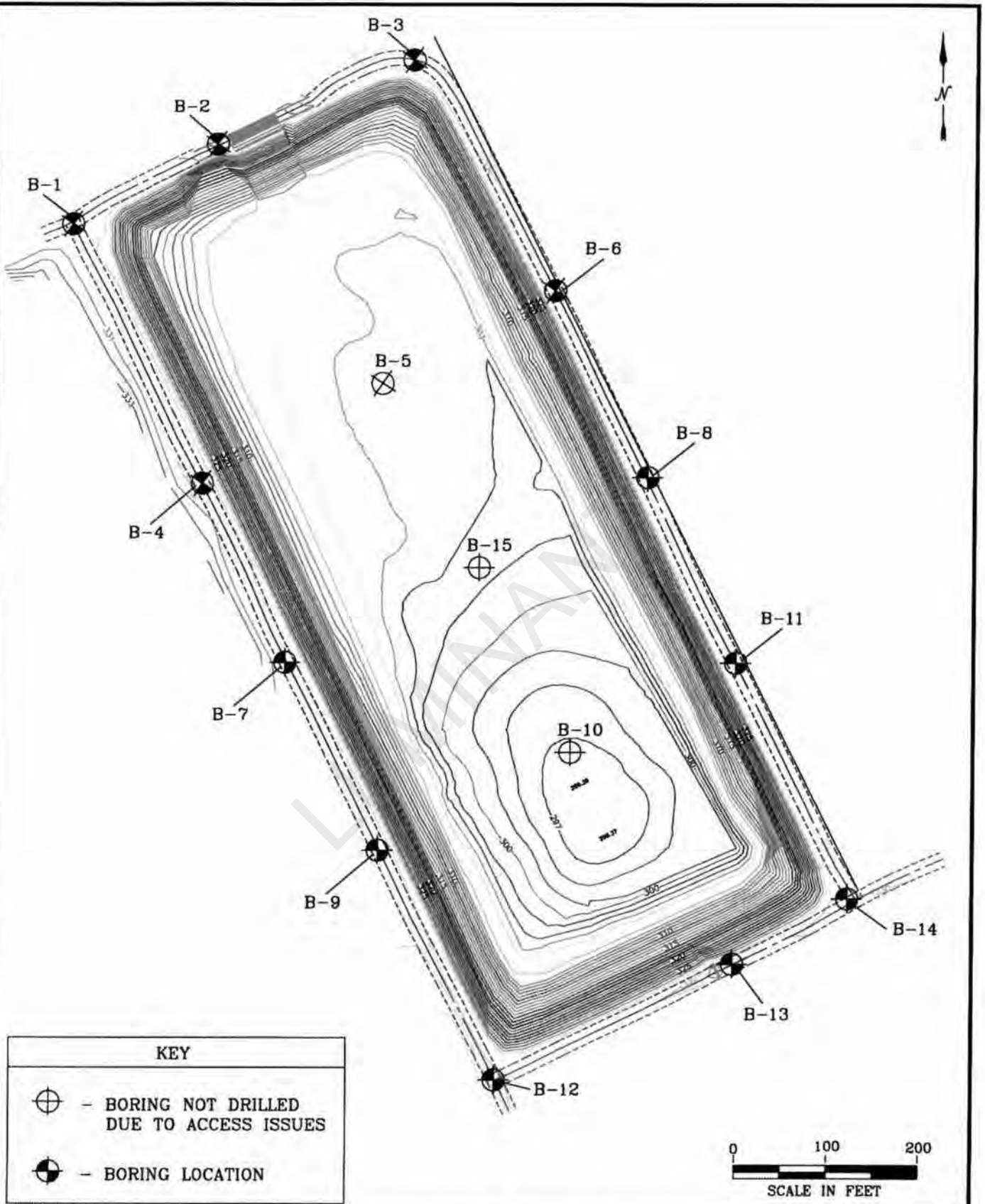

KEY	
	- BORING NOT DRILLED DUE TO ACCESS ISSUES
	- BORING LOCATION

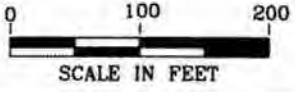

**ETTL
ENGINEERS &
CONSULTANTS**
MAIN OFFICE
1717 East Greer
Ft. Worth, Texas 75102
(803) 595-4421

**MARTIN LAKE
LUMINANT
EAST ASH DISPOSAL POND
RUSK COUNTY, TEXAS**

PLATE 1 - PLAN OF BORINGS
JOB NO.: G 2972-08
DATE: NOV. 2008 SCALE: AS SHOWN

APPROVED BY:

DRAWN BY:
K.C.R.



**ETTL
ENGINEERS &
CONSULTANTS**

MAIN OFFICE
1717 East Erwin
Tyler, Texas 75702
(903) 595-4421

MATERIAL DESCRIPTION

SANDY LEAN CLAY (CL) hard; red, tan, and gray; mottled
-very stiff
-with trace lignite

-hard

SILTY SAND (SM) medium dense; red, tan, and gray
-with gravel

LEAN CLAY WITH SAND (CL) very stiff; red, tan, and gray; interbedded; laminated
Bottom of Boring @ 40'

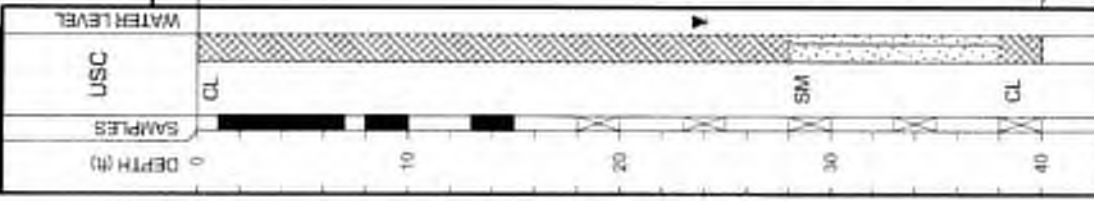

Water Level: Measured Predicted

Seepage @ 26' while drilling. Water level @ 26' and open to 33' upon completion. Water level @ 24' and open to 27' on 10/19/05.

LOG OF BORING B-1										DATE 10/8/08			
PROJECT: Martin Lake - Luminant East Ash Disposal Rusk County, Texas										SURFACE ELEVATION			
PROJECT NO.: G 2972-08										BORING TYPE: Flight Auger			
FIELD STRENGTH	BLOW COUNT	Cu (tsf)	PPR (tsf)	Terzaghi (tsf)	DRY DENSITY (pcf)	COMPRESSIVE STRENGTH (tsf)	FAILURE STRAIN (%)	CONFINING PRESSURE (psf)	Natural Moisture Content and Atterberg Limits			OTHER TESTS (Page Ref. #)	
									Moisture Content	Plastic Limit	Liquid Limit		
									LL	PL	PI		
P=4.5+	1	1.0	1.0	1.0	115				29	14	14	55	+40 Sieve =0%, +4 Sieve =0%
P=3.75	2	2.0	2.0	2.0	115				37	14	23	66	+40 Sieve =1%, +4 Sieve =0%
P=3.0	3	3.0	3.0	3.0	115				39	16	23	70	+40 Sieve =1%, +4 Sieve =0%
P=2.75	4	4.0	4.0	4.0	115								
P=4.5+													
N=11													
N=16													
N=19													
N=22													
N=17													

Key to Abbreviations
N - SPT Data (Blows/Ft)
P - Pocket Penetrometer (tsf)
T - Terzaghi (tsf)
L - Lab Vane Shear (tsf)

Notes
GPS Coordinates: N 32° 15.850', W 94° 33.910'



**ETTL
ENGINEERS &
CONSULTANTS**

MAIN OFFICE
1717 East Erwin
Tyler, Texas 75702
(903) 505-4421

LOG OF BORING B-11
PROJECT: Martin Lake - Luminant East Ash Disposal
Rusk County, Texas
PROJECT NO.: G 2972-08
BORING TYPE: Flight Auger

DATE: 10/7/08
SURFACE ELEVATION

FIELD STRENGTH DATA	BLOW COUNT ● C _u (blf) ▲ C _w (blf) ■ PPR (blf) ◆ Torvane (blf)	DRY DENSITY (pcf)	COMPRESSION STRENGTH (blf)	FAILURE STRAIN (%)	CONFINING PRESSURE (psf)	Natural Moisture Content and Atterberg Limits		MOISTURE CONTENT (%)	ATTERBERG LIMITS (%)			OTHER TESTS PERFORMED (Page Ref. #)
						Plastic Limit	Liquid Limit		PL	PL	PI	
P=3.0 P=2.25 N=17	● 3.0 ▲ 2.25 ◆ 1.7					28	12	6	28	12	16	+40 Sieve =28% +4 Sieve =24%
N=11	◆ 1.1							13	32	13	19	+40 Sieve =1% +4 Sieve =0%
P=2.25 P=3.25 P=2.25	■ 2.25 ■ 3.25 ■ 2.25							16	38	14	24	+40 Sieve =1% +4 Sieve =0%
N=15 N=16	◆ 1.5 ◆ 1.6											

MATERIAL DESCRIPTION

CLAYEY SAND(SC) tan, gray, and red, mottled,
with gravel

SANDY LEAN CLAY(CL) very stiff, tan, gray, and
red, mottled

--stiff

--red and gray, mottled

--tan, red, and gray, mottled

SILTY SAND(SM) medium dense, gray

Bottom of Boring @ 40'

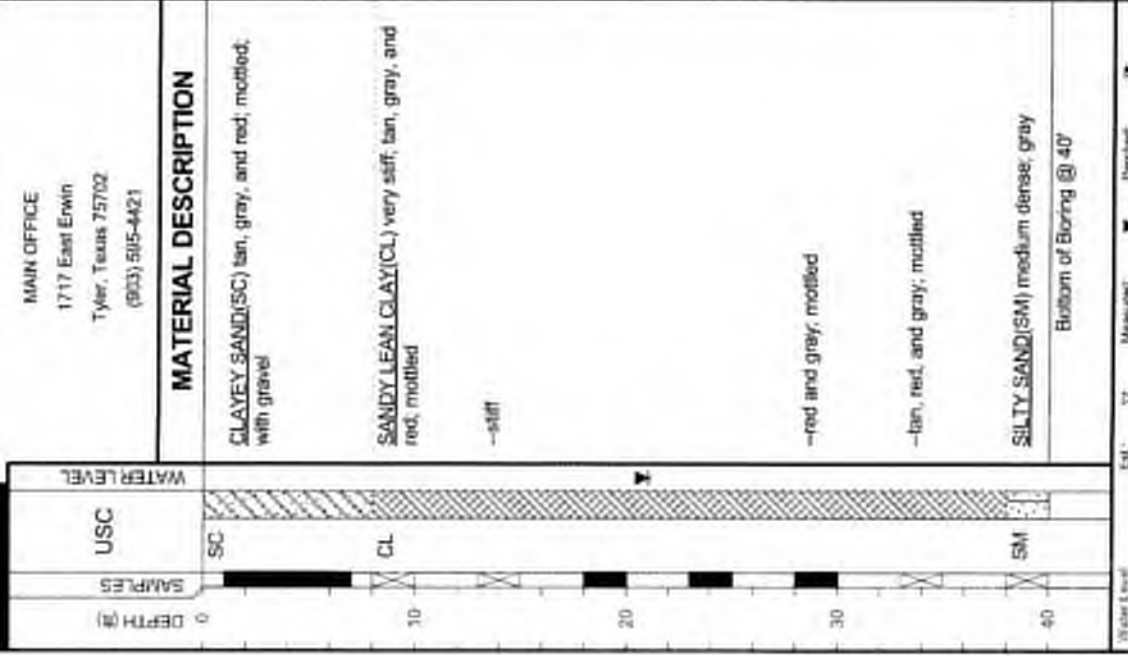

Scale: Estimated Measured Partial

Notes:
 N - SPT Data (Blows/Ft)
 P - Pocket Penetrometer (blf)
 T - Torvane (blf)
 L - Lab Vane Shear (blf)

GPS Coordinates: N 32°15.773', W 94°33.782'



**ETTL
ENGINEERS &
CONSULTANTS**

MAIN OFFICE
1717 East Erwin
Tyler, Texas 75702
(903) 565-4421

MATERIAL DESCRIPTION

SANDY LEAN CLAY (CL) brown; with gravel
-mottled, tan, red, and gray; with sand seams

-with silty sand

LEAN CLAY WITH SAND (CL) very stiff, tan, red,
and gray; mottled

-with sand seams

SILTY SAND (SM) dense; gray and red; mottled

SANDY LEAN CLAY (CL) very stiff; gray, red, and
tan; mottled
Bottom of Boring @ 40'

WATER LEVEL

USC

SAMPLES

DEPTH (ft)

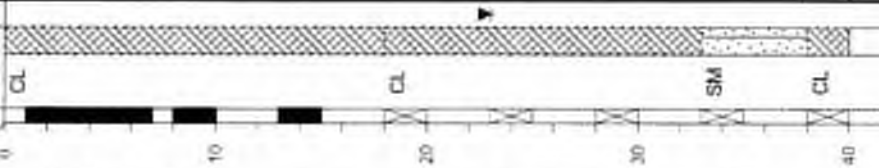

LOG OF BORING B-12

PROJECT: Martin Lake - Luminant East Ash Disposal
Rusk County, Texas

PROJECT NO.: G 2972-08

BORING TYPE: Flight Auger

DATE

10/19/08

SURFACE ELEVATION

MOISTURE CONTENT (%)		ATTERBERG LIMITS (%)		MINUS #200 SIEVE (%)	OTHER TESTS PERFORMED (Page Ref. #)
LL	PL	LIQUID LIMIT	PLASTIC LIMIT		
13	13	32	15	54	+40 Sieve =1%, +4 Sieve =0%, +40 Sieve =0%, +4 Sieve =0%
16	16	30	14	75	+40 Sieve =1%, +4 Sieve =0%

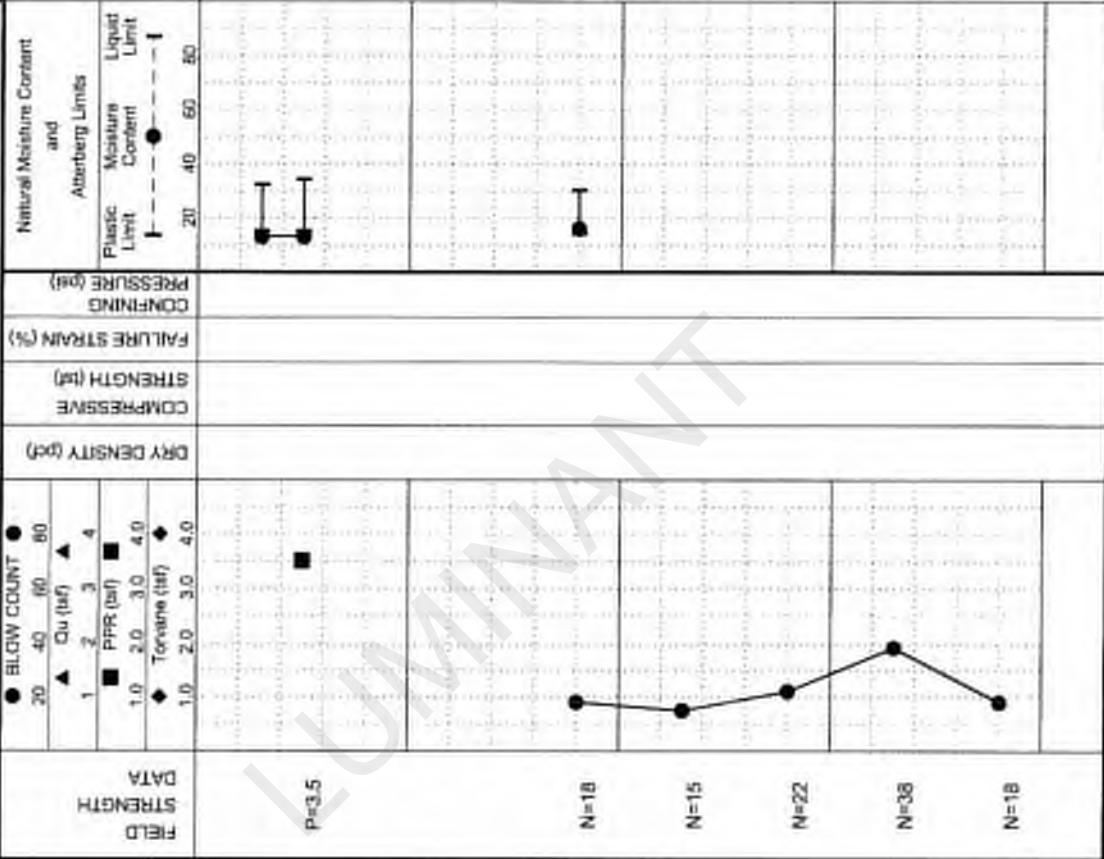

FIELD STRENGTH DATA	DRY DENSITY (pcf)	COMPRESSION STRENGTH (lb)	FAILURE STRAIN (%)	CONFINING PRESSURE (psf)	Natural Moisture Content and Atterberg Limits
P=3.5					
N=18					
N=15					
N=22					
N=38					
N=18					

GPS Coordinates: N 32° 15.696', W 94° 33.830'

Water Level: Seepage @ 33' while drilling. Water level @ 34' and open to 35' upon completion. Water level @ 23' and open to 31' on 10/10/08.

Key to Abbreviations:
N - SPT Data (Blows/Ft)
P - Pocket Penetration (psi)
T - Torque (ft-ft)
L - Lab. Vane Shear (psi)



**ETTL
ENGINEERS &
CONSULTANTS**

MAIN OFFICE
1717 East Erwin
Tyler, Texas 75702
(903) 595-4421

DEPTH (ft)
SAMPLES
USC
WATER LEVEL

MATERIAL DESCRIPTION

SANDY LEAN CLAY (CL) very stiff; tan, gray, and red; mottled
LEAN CLAY WITH SAND (CL) very stiff; tan, gray, and red; mottled
-tan and brown
CLAYEY SAND (SC) dense; tan, brown, and red; with gravel
LEAN CLAY WITH SAND (CL) very stiff; tan, brown, and red; with lignite
-red and tan
-tan, red, and gray; mottled
CLAYEY SAND (SC) loose; tan, red, and gray; with trace gravel and ferrous material
-medium dense
Bottom of Boring @ 40'

LOG OF BORING B-13
PROJECT: Marlin Lake - Luminant East Ash Disposal
Rusk County, Texas
PROJECT NO.: G 2972-08
BORING TYPE: Flight Auger

FIELD STRENGTH DATA	BLOW COUNT 20 40 60 80 ▲ Ou (tsf) ▲ 1 2 3 4 ■ PPR (tsf) ■ 1.0 2.0 3.0 4.0 ◆ Terzani (tsf) ◆	DRY DENSITY (pcf)	COMPRESSIVE STRENGTH (tsf)	FAILURE STRAIN (%)	CONFINING PRESSURE (psf)	Natural Moisture Content and Atterberg Limits		MOISTURE CONTENT (%)	ATTERBERG LIMITS (%)			OTHER TESTS PERFORMED (Page Ref. #)	
						Plastic Limit	Liquid Limit		LIQUID LIMIT	PLASTIC LIMIT	PLASTICITY INDEX		MINUS #200 SIEVE (%)
P=3.25	■					20	35	15	39	16	23	70	+40 Sieve =6%
P=3.0	■					20	35	10	40	16	24	47	+40 Sieve =36%, +4 Sieve =33%
P=3.75	■					20	35	17	38	16	22	74	+40 Sieve =3%, +4 Sieve =0%
P=3.25	■					20	35	18	36	17	19	43	+40 Sieve =36%, +4 Sieve =25%
P=2.75	■					20	35						
P=2.0	■					20	35						
P=2.25	■					20	35						
N=18	●					20	35						
N=9	●					20	35						
N=18	●					20	35						

Notes:
GPS Coordinates: N 32°15.713', W 94°33.777'

Key to Abbreviations:
N - SPT Data (Blows/Ft)
P - Pocket Penetrometer (tsf)
T - Terzani (tsf)
L - Lab Vane Shear (tsf)

Water Level
Water Coordinates
@ 36' and open to 38' upon completion. Water level @ 25' and open to 26' on 10/8/08.

Scale: Measure Partial

Seepage @ 37' while drilling. Water level @ 36' and open to 38' upon completion. Water level @ 25' and open to 26' on 10/8/08.



**ETTL
ENGINEERS &
CONSULTANTS**

MAIN OFFICE
1717 East Erwin
Tyler, Texas 75702
(903) 595-4421

MATERIAL DESCRIPTION

SANDY LEAM CLAY (CL) hard, tan, gray, and red;
mottled; with gravel

-silt

SANDY LEAM CLAY (CL) very stiff, tan, gray, and
red; mottled

-silt; interbedded

-hard, brown, tan, and red

-hard, with gray and brown silty sand

SILTY SAND (SM) medium dense, red and gray;
saturated

Water Level: Measured Perched
Water Observed on: Water level @ 22' and open to 89' upon
completion. Water level @ 26' and open to 27' on 10/9/08.

LOG OF BORING B-14

PROJECT: Marlin Lake - Luminant East Ash Disposal
Rusk County, Texas

PROJECT NO.: G 2972-08

BORING TYPE: Flight Auger

DATE

10/6/08

SURFACE ELEVATION

ATTERBERG LIMITS (%)		MINUS #200 SIEVE (%)	OTHER TESTS (Page Ref. #)
LIQUID LIMIT	PLASTIC LIMIT		

14	40	16	24	53	+40 Sieve =50%, +4 Sieve =40%
13	29	13	16	63	+40 Sieve =1%, +4 Sieve =0%
16	31	16	15	58	+40 Sieve =2%, +4 Sieve =0%
12	40	14	26	77	+40 Sieve =1%, +4 Sieve =0%

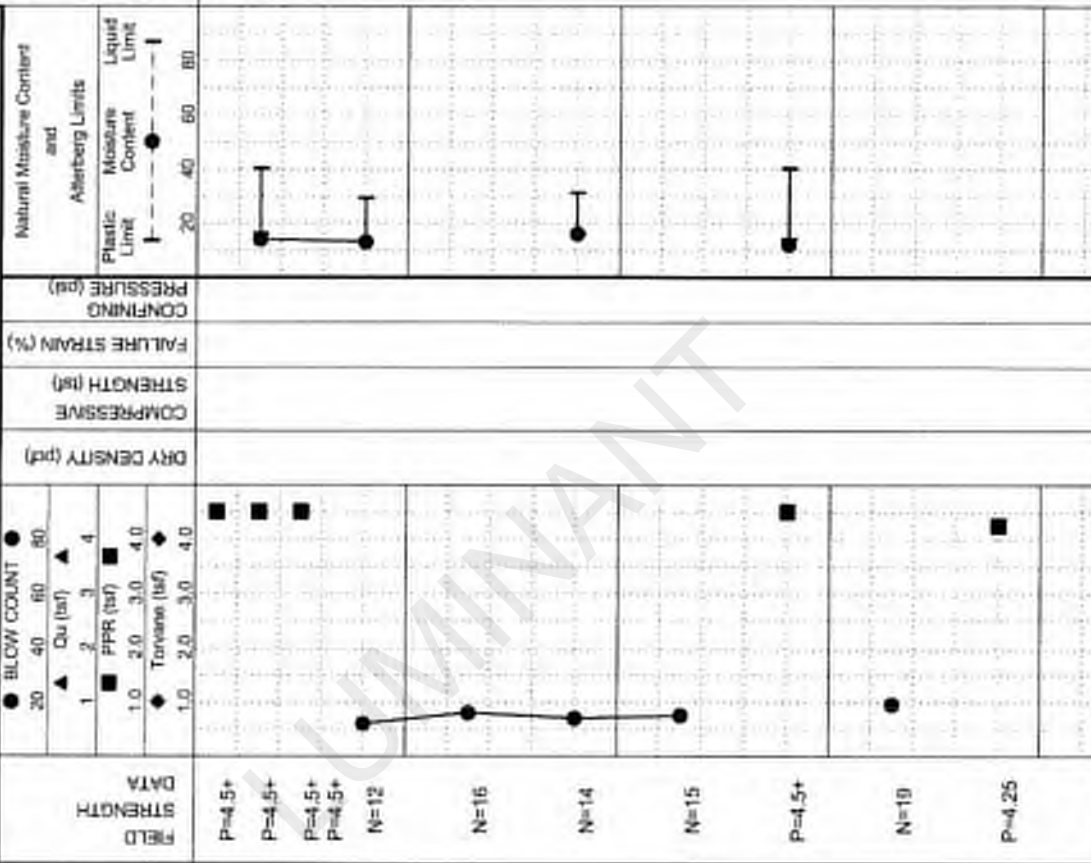

Notes:
GPS Coordinates: N 32°15.723', W 94°33.756'



DEPTH (ft)	USC	FIELD STRENGTH DATA	DRY DENSITY (pcf)	COMPRESSIONIVE STRENGTH (ksf)	FAILURE STRAIN (%)	CONFINING PRESSURE (psf)	Natural Moisture Content and Atterberg Limits
0	CL	P=4.5+	1.0	1.0	1.0	1.0	14, 24, 53
10	CL	P=4.5+	2.0	2.0	2.0	2.0	13, 16, 63
20	CL	P=4.5+	3.0	3.0	3.0	3.0	16, 15, 58
30	SM	P=4.5+	4.0	4.0	4.0	4.0	12, 26, 77
40	SM	P=4.25	4.0	4.0	4.0	4.0	-



**ETTL
ENGINEERS &
CONSULTANTS**

MAIN OFFICE
1717 East Erwin
Tyler, Texas 75702
(903) 995-4421

MATERIAL DESCRIPTION

USC
WATER LEVEL

50

CL

60

SM

70

80

CL

---red and tan

LEAN CLAY WITH SAND (CL) hard; red and tan; interbedded; laminated; with form material seams

---with black lignite seams

SILTY SAND (SM) very dense; gray; with fat clay partings

---gray

LEAN CLAY (CL) hard; gray

Water Level

Water Observations:
Water level @ 22' and open to 88' upon completion. Water level @ 26' and open to 27' on 10/9/08.

Est. Measure Perched

LOG OF BORING B-14										DATE					
PROJECT: Martin Lake - Luminant East Ash Disposal Rusk County, Texas										10/6/08					
PROJECT NO.: G 2972-08										SURFACE ELEVATION					
BORING TYPE: Flight Auger										OTHER TESTS PERFORMED (Page Ref. #)					
FIELD STRENGTH DATA	BLOW COUNT	Qu (tsf)	PPR (tsf)	Torque (tsf)	DRY DENSITY (pcf)	COMPRESSIVE STRENGTH (ksf)	FAILURE STRAIN (%)	CONFINING PRESSURE (psf)	Natural Moisture Content and Atterberg Limits		MOISTURE CONTENT (%)	MINUS #200 SIEVE (%)	ATTERBERG LIMITS (%)	PLASTICITY INDEX	
									Plastic Limit	Liquid Limit					
N=16	1	1.0	1.0	1.0	1.0				22	22	25	25	25	25	+40 Sieve =1%, +4 Sieve =0%
N=16	2	2.0	2.0	2.0	2.0				22	22	77	77	77	77	+40 Sieve =3%, +4 Sieve =0%
N=23	3	3.0	3.0	3.0	3.0				24	24	41	41	41	41	+40 Sieve =0%, +4 Sieve =0%
N=32	4	4.0	4.0	4.0	4.0				24	24	41	41	41	41	+40 Sieve =0%, +4 Sieve =0%
N=50/3*	5	5.0	5.0	5.0	5.0				24	24	41	41	41	41	+40 Sieve =0%, +4 Sieve =0%
N=50/5.5*	6	6.0	6.0	6.0	6.0				24	24	41	41	41	41	+40 Sieve =0%, +4 Sieve =0%
N=50/5*	7	7.0	7.0	7.0	7.0				24	24	41	41	41	41	+40 Sieve =0%, +4 Sieve =0%
N=50/8*	8	8.0	8.0	8.0	8.0				24	24	41	41	41	41	+40 Sieve =0%, +4 Sieve =0%
N=50/8*	9	9.0	9.0	9.0	9.0				24	24	41	41	41	41	+40 Sieve =0%, +4 Sieve =0%

Notes:
GPS Coordinates: N 32° 15.723', W 94° 33.756'

Key to Abbreviations:
N - SPT Data (Blow/ft)
P - Pocket Penetrometer (tsf)
T - Torque (tsf)
L - Lab Vane Shear (ksf)



**ETTL
ENGINEERS &
CONSULTANTS**

MAIN OFFICE
1717 East Erwin
Tyler, Texas 75702
(903) 595-4421

MATERIAL DESCRIPTION

--with black lignite

--dark brown; with silt seams; with lignite seam

Bottom of Boring @ 100'

DEPTH (#)
SAMPLES
USC
WATER LEVEL

90

100

Water Level: Est. Measured Perched
Water Observations: Water level @ 22' and open to 89' upon completion. Water level @ 26' and open to 27' on 10/9/08.

LOG OF BORING B-14

PROJECT: Martin Lake - Luminant East Ash Disposal
Rusk County, Texas

PROJECT NO.: G 2972-08

BORING TYPE: Flight Auger

DATE

10/6/08

SURFACE ELEVATION

MOISTURE CONTENT (%)

ATTERBERG LIMITS(%)

LIQUID LIMIT

PLASTIC LIMIT

PLASTICITY INDEX

MINUS #200 SIEVE (%)

OTHER TESTS PERFORMED (Page Ref. #)

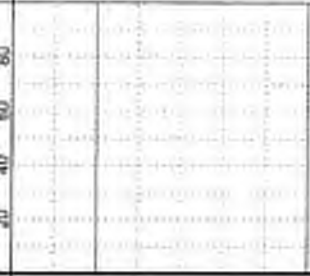

FIELD STRENGTH	DRY DENSITY (pcf)	COMPRESSIONIVE STRENGTH (ksf)	FAILURE STRAIN (%)	CONFINING PRESSURE (psf)
N=50/3.5	1.0	2.0	3.0	4.0
N=50/6	1.0	2.0	3.0	4.0
N=68	1.0	2.0	3.0	4.0

BLOW COUNT	QU (tsf)	PPR (tsf)	TORVANE (tsf)
1	2	3	4
20	40	60	80

Key to Abbreviations:
N - SPT Data (Blows/Ft)
P - Pressure Pycnometer (pcf)
T - Torvane (tsf)
L - Lab Vane Shear (tsf)

Notes:
GPS Coordinates: N 32°15.723', W 94°33.756'



**ETTL
ENGINEERS &
CONSULTANTS**

MAIN OFFICE
1717 East Erwin
Tyler, Texas 75702
(903) 595-4421

MATERIAL DESCRIPTION

SANDY LEAM CLAY (CL) very stiff, tan, red, and gray

-hard, red, tan, and gray, mottled

-with some gravel

-tan, red, and gray, mottled

-gray, red, and tan, mottled

SILTY SAND (SM) medium dense, red and gray, saturated

Bottom of Boring @ 40'

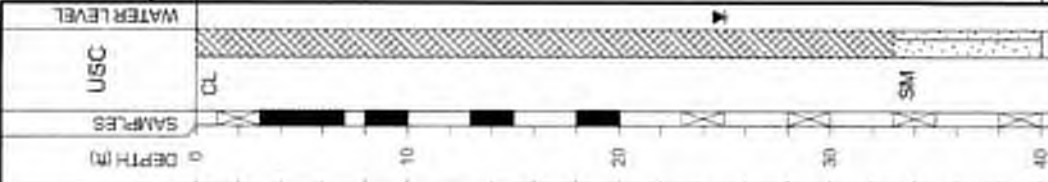

Water Level: Measured Perched
 Water Column:
 Seepage @ 32' while drilling. Water level @ 29' and open to 32' upon completion. Water level @ 25' and open to 25' on 10/9/08.

Key to Abbreviations
 N - SPT Data (blows/ft)
 P - Proctor Parameters (pcf)
 T - Torvane (pcf)
 L - Lab Vane Shear (pcf)

Notes:

GPS Coordinates: N 32°15.860', W 94°33.890'

LOG OF BORING B-2

PROJECT: Martin Lake - Luminant East Ash Disposal
Rusk County, Texas

PROJECT NO.: G 2972-08

BORING TYPE: Flight Auger

DATE

10/8/08

SURFACE ELEVATION

ATTERBERG LIMITS (%)		MOISTURE CONTENT (%)	OTHER TESTS PERFORMED (Page Ref. #)
LIQUID LIMIT	PLASTIC LIMIT		
LL	PL	8	+40 Sieve = 0%, +4 Sieve = 0%
32	14		
LI	PI	17	+40 Sieve = 1%, +4 Sieve = 0%
28	15		
LI	PI	13	+40 Sieve = 0%, +4 Sieve = 0%
39	15		
MINUS #200 SIEVE (%)		50	

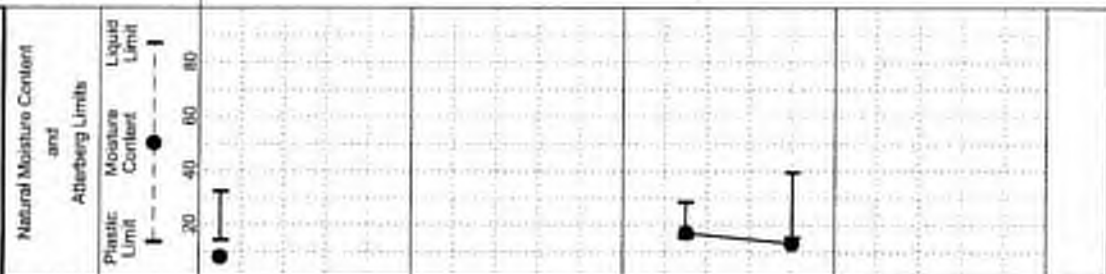

FIELD STRENGTH DATA	DRY DENSITY (pcf)	COMPRESSIVE STRENGTH (ksf)	FAILURE STRAIN (%)	CONFINING PRESSURE (psf)
N=19				
P=4.25				
P=3.75				
P=4.0				
P=4.5+				
N=1				
N=22				
N=15				
N=13				

FIELD STRENGTH DATA	BLOW COUNT		TORVANE (pcf)
	1	2	
N=19	1	2	1.0
P=4.25	3	4	2.0
P=3.75	3	4	3.0
P=4.0	3	4	4.0
P=4.5+	3	4	4.0
N=1	1	2	1.0
N=22	1	2	1.0
N=15	1	2	1.0
N=13	1	2	1.0

FIELD STRENGTH DATA	QU (ksf)	FPR (ksf)
N=19	1	2
P=4.25	3	4
P=3.75	3	4
P=4.0	3	4
P=4.5+	3	4
N=1	1	2
N=22	1	2
N=15	1	2
N=13	1	2



**ETTL
ENGINEERS &
CONSULTANTS**

MAIN OFFICE
1717 East Erwin
Tyler, Texas 75702
(903) 596-4421

DEPTH (ft)
SAMPLERS
USC
WATER LEVEL

MATERIAL DESCRIPTION

SANDY LEAN CLAY (CL) very stiff, tan, red, and gray, mottled

-stiff

CLAYEY SAND (SC) medium dense; red

-gray

LEAN CLAY WITH SAND (CL) stiff, red, tan, and gray, mottled

-with sand seams

CLAYEY SAND (SC) medium dense; gray and red; mottled; with clay seams

Bottom of Boring @ 40'

Water Observations:
Seepage @ 29' while drilling. Water level @ 28' and open to 34' upon completion. Water level @ 25' and open to 32' on 10/8/08.

Est. Measured Perched
Water Level

LOG OF BORING B-3											
PROJECT: Martin Lake - Luminant East Ash Disposal Rusk County, Texas					DATE: 10/8/08						
PROJECT NO.: G 2972-08					SURFACE ELEVATION						
BORING TYPE: Flight Auger					OTHER TESTS PERFORMED (Page Ref. #)						
FIELD STRENGTH DATA	BLOW COUNT	DRY DENSITY (pcf)	COMPRESSIVE STRENGTH (qsf)	FAILURE STRAIN (%)	CONFINING PRESSURE (psf)	MOISTURE CONTENT (%)			ATTERBERG LIMITS (%)		
						LIQUID LIMIT	PLASTIC LIMIT	PLASTICITY INDEX			
SPIT	PPR	Qu	Torsion	Natural Moisture Content	Moisture Constant	Plastic Limit	Liquid Limit	PL	PI		
P=3.5	1	3.5	1.5	15	15	18	33	13	20	68	+40 Sieve =1%, +4 Sieve =0%
P=2.5	2	2.5	1.5	15	15	10	37	15	22	19	+40 Sieve =15%, +4 Sieve =7%
P=3.0	3	3.0	1.5	15	15	18	34	16	18	71	+40 Sieve =5%, +4 Sieve =0%
P=3.5	4	3.5	1.5	15	15						
N=15											
N=4											
N=15											
N=13											
N=13											

Key to Abbreviations:
N - SPIT Data (Blows/ft)
P - Pocket Penetrometer (pp)
T - Torsion (tsf)
L - Lab. Moist. Shear (pcf)

Notes:
GPS Coordinates: N 32°15.876', W 94°33.842'



**ETTL
ENGINEERS &
CONSULTANTS**

MAIN OFFICE
1717 East Erwin
Tyler, Texas 75702
(803) 595-4421

DEPTH (ft)
SAMPLES
USC
WATER LEVEL

MATERIAL DESCRIPTION

SANDY LEAN CLAY (CL) stiff, tan, red, and gray; modified
CL

CLAYEY SAND (SC) red, tan, and gray; modified
SC

SANDY LEAN CLAY (CL) stiff, tan, red, and gray; modified; with sand seams
CL

-red and tan

-with sand seams

SILTY SAND (SM) medium dense, red, saturated
SM

-red and tan, with gravel
Bottom of Boring @ 40'

Water Level
Water Observations
@ 27' and open to 30' upon completion. Water level @ 23' and open to 28' on 10/9/08.

Est Manual Perched

LOG OF BORING B-4

PROJECT: Martin Lake - Luminant East Ash Disposal
Rusk County, Texas
PROJECT NO.: G 2972-08
BORING TYPE: Flight Auger

DATE 10/9/08

SURFACE ELEVATION

FIELD STRENGTH DATA	BLOW COUNT 20 40 60 80	QU (tsf) 1 2 3 4	PPR (tsf) 1.0 2.0 3.0 4.0	Torsion (tsf) 1.0 2.0 3.0 4.0	DRY DENSITY (pcf)	COMPRESSIVE STRENGTH (tsf)	FAILURE STRAIN (%)	CONFINING PRESSURE (tsf)	Natural Moisture Content and Atterberg Limits			MOISTURE CONTENT (%)	MINUS #200 SIEVE (%)	OTHER TESTS PERFORMED (Page Ref. #)	
									Plastic Limit	Moisture Constant	Liquid Limit				LIQUID LIMIT LL
N=13 P=2.5 P=4.5+P=2.0	●	▲	■	◆						25	14	14	13	60	+40 Sieve =1%, +4 Sieve =0%
N=14	●									25	14	15	14	36	+40 Sieve =0%, +4 Sieve =0%
N=12	●									25	14	29	15	67	+40 Sieve =0%, +4 Sieve =0%
N=20	●									25	14	29	15	67	+40 Sieve =0%, +4 Sieve =0%
N=20	●									25	14	29	15	67	+40 Sieve =0%, +4 Sieve =0%
N=39	●									25	14	29	15	67	+40 Sieve =0%, +4 Sieve =0%

Key to Abbreviations
N - SPT Data (Blows/Ft)
P - Pocket Penetrometer (tsf)
T - Torque (tsf)
L - Lab Vane Shear (tsf)

Notes:
GPS Coordinates: N 32°15.804', W 94°33.891'



**ETTL
ENGINEERS &
CONSULTANTS**

MAIN OFFICE
1717 East Erwin
Tyler, Texas 75702
(903) 595-4421

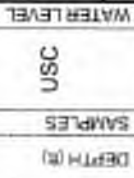

MATERIAL DESCRIPTION

SANDY LEAN CLAY (CL) very stiff, tan, red, and gray, mottled

CLAYEY SAND (SC) medium dense; tan, red, and gray, mottled

LEAN CLAY (CL) stiff, tan, red, and gray, mottled

-very stiff, brown, gray, and red; with sand; trace ferric material and lignite

-with sand seams

-tan, red, and gray, mottled

-tan and gray, mottled

SILTY SAND (SM) tan and gray
SANDY LEAN CLAY (CL) very stiff, tan and gray
Bottom of Boring @ 40'

Water Level

Water Observations

@ 26' and open to 34' upon completion. Water level @ 25' and open to 27' on 10/8/08.

Est: Measured Percut

LOG OF BORING B-6

PROJECT: Martin Lake - Luminant East Ash Disposal
Rusk County, Texas

PROJECT NO.: G 2972-08

BORING TYPE: Flight Auger

DATE

10/7/08

SURFACE ELEVATION

FIELD DATA	BLOW COUNT	DRY DENSITY (pcf)	COMPRESSIVE STRENGTH (tsf)	FAILURE STRAIN (%)	CONFINING PRESSURE (psf)	Natural Moisture Content and Atterberg Limits		MOISTURE CONTENT (%)	ATTERBERG LIMITS (%)	MINUS #200 SIEVE (%)	OTHER TESTS PERFORMED (Page Ref. #)
						Plastic Limit	Liquid Limit				
P=3.5	1.0 2.0 3.0 4.0					20 40 60 80		11	LL 31 PL 16 PI 15	43	+40 Sieve =1% +4 Sieve =0%
P=4.5+	1.0 2.0 3.0 4.0							19	LL 45 PL 16 PI 29	88	+40 Sieve =0% +4 Sieve =0%
N=17	1.0 2.0 3.0 4.0							14	LL 46 PL 17 PI 29	74	+40 Sieve =0% +4 Sieve =0%
N=24	1.0 2.0 3.0 4.0							16	LL 46 PL 17 PI 29	64	+40 Sieve =8% +4 Sieve =0%
P=1.75	1.0 2.0 3.0 4.0										
P=3.25	1.0 2.0 3.0 4.0										
N=19	1.0 2.0 3.0 4.0										
N=25	1.0 2.0 3.0 4.0										
N=18	1.0 2.0 3.0 4.0										
N=18	1.0 2.0 3.0 4.0										

Key to Abbreviations

N - SPT Data (Blows/Ft)

P - Pocket Penetrometer (tsf)

T - Torvane (tsf)

L - Lab Vane Shear (psf)

Notes:

GPS Coordinates: N 32°15.833', W 94°33.814'



**ETTL
ENGINEERS &
CONSULTANTS**

MAIN OFFICE
1717 East Erwin
Tyler, Texas 75702
(803) 595-4421

MATERIAL DESCRIPTION

SANDY LEAN CLAY (CL) hard, tan, red, and gray, mottled
 SANDY SILTY CLAY (CL-ML) very stiff, tan, red, and gray, mottled
 LEAN CLAY WITH SAND (CL) very stiff, tan, red, and gray, mottled
 -stiff
 FAT CLAY (CH) stiff, gray, red, and tan, mottled
 SILTY SAND (SM) medium dense, tan, red, gray, mottled
 SANDY LEAN CLAY (CL) very stiff, red, tan, and gray, mottled

Bottom of Boring @ 40'

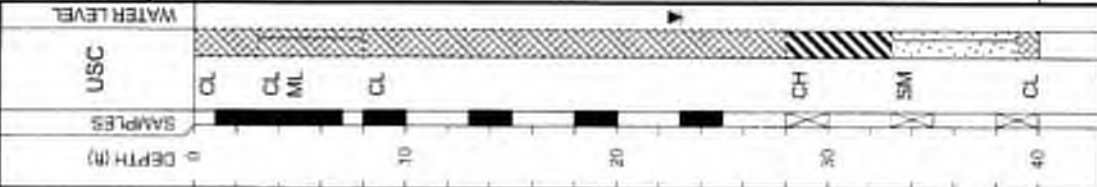

Water Level: Measured Perched
 Water Observations:
 @ 32' and open to 35' upon completion. Water level @ 23' and open to 27' on 10/9/08.

LOG OF BORING B-7

PROJECT: Martin Lake - Luminant East Ash Disposal
Rusk County, Texas

PROJECT NO.: G 2972-08

BORING TYPE: Flight Auger

DATE: 10/8/08

SURFACE ELEVATION

MOISTURE CONTENT (%)		ATTERBERG LIMITS (%)		OTHER TESTS PERFORMED (Page Ref. #)
LL	PL	PL	PI	
25	55	19	36	+40 Sieve = 1% +4 Sieve = 0%
15	36	15	21	+40 Sieve = 0% +4 Sieve = 0%
15	34	16	18	+40 Sieve = 1% +4 Sieve = 0%
63	14	14	7	+40 Sieve = 0% +4 Sieve = 0%

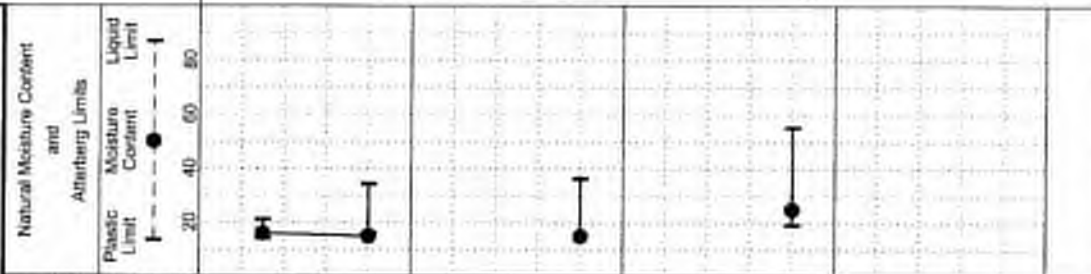

FIELD STRENGTH DATA	DRY DENSITY (pcf)	COMPRESSIONIVE STRENGTH (tsf)	FAILURE STRAIN (%)	CONFINING PRESSURE (psf)
P=4.0				
P=3.0				
P=3.0				
P=3.25				
P=1.5				
P=1.5				
N=11				
N=10				
N=20				



FIELD STRENGTH DATA	DRY DENSITY (pcf)	COMPRESSIONIVE STRENGTH (tsf)	FAILURE STRAIN (%)	CONFINING PRESSURE (psf)
P=4.0				
P=3.0				
P=3.0				
P=3.25				
P=1.5				
P=1.5				
N=11				
N=10				
N=20				

Notes:
 GPS Coordinates: N 32°15.775', W 94°33.875'
 Key to Abbreviations:
 N - SPT Data (Blows/Ft)
 P - Pocket Penetrometer (tsf)
 T - Torque (tsf)
 L - Lab Vane Shear (tsf)



**ETTL
ENGINEERS &
CONSULTANTS**

MAIN OFFICE
1717 East Erwin
Tyler, Texas 75702
(936) 595-4421

USC
SAMPLES
DEPTH (ft)

MATERIAL DESCRIPTION

SANDY LEAN CLAY (CL) hard; tan, red, and gray;
mottled

--very silt

--red and gray; mottled

SILTY SAND(SM) dense; red, tan, and reddish
gray; moist; saturated

Bottom of Boring @ 40'

Water Level
Water Observations
@ 35' and open to 36' upon completion. Water level @ 23' and
open to 27' on 10/8/08.

Ed: Measured Filled

LOG OF BORING B-8										
PROJECT: Martin Lake - Luminant East Ash Disposal Rusk County, Texas					DATE: 10/7/08					
PROJECT NO.: G 2972-08					SURFACE ELEVATION					
BORING TYPE: Flight Auger					OTHER TESTS PERFORMED (Page Ref. #)					
FIELD STRENGTH DATA	BLOW COUNT 20 40 60 80 ▲ Or (tsf) ▲ 1 2 3 4 ■ PFR (tsf) ■ 1.0 2.0 3.0 4.0 ◆ Torque (tsf) ◆	DRY DENSITY (pcf)	COMPRESSION STRENGTH (ksf)	FAILURE STRAIN (%)	CONFINING PRESSURE (ksf)	Natural Moisture Content and Atterberg Limits			MOISTURE CONTENT (%)	
						Plastic Limit	Shrinkage Limit	Liquid Limit		
PLASTICITY INDEX	PLASTIC LIMIT	LIQUID LIMIT	PL	PL	PL	PI	PI	MINUS #200 SIEVE (%)		
P=4.5+	■	■				20	17	30	11	+40 Sieve =2%, +4 Sieve =0%
P=4.5+	■	■				20	17	30	11	+40 Sieve =2%, +4 Sieve =0%
P=3.5	■	■				20	16	29	13	+40 Sieve =0%, +4 Sieve =0%
P=4.0	■	■				20	16	29	13	+40 Sieve =0%, +4 Sieve =0%
P=3.5	■	■				20	16	29	13	+40 Sieve =0%, +4 Sieve =0%
N=15	●	●				20	25	44	16	+40 Sieve =3%, +4 Sieve =0%
P=2.5	■	■				20	25	44	16	+40 Sieve =3%, +4 Sieve =0%
N=15	●	●				20	20	36	16	+40 Sieve =0%, +4 Sieve =3%
N=16	●	●				20	20	36	16	+40 Sieve =0%, +4 Sieve =3%
N=26	●	●				20	20	36	16	+40 Sieve =0%, +4 Sieve =3%

Notes:
GPS Coordinates: N 32°15.803', W 94°33.798'

Key to Abbreviations
N - SPT Data (blows/ft)
P - Pocket Penetrometer (ksf)
T - Torque (tsf)
L - Lab Vane Shear (psf)

PERMANENT DISPOSAL POND - 5

LUMINANT

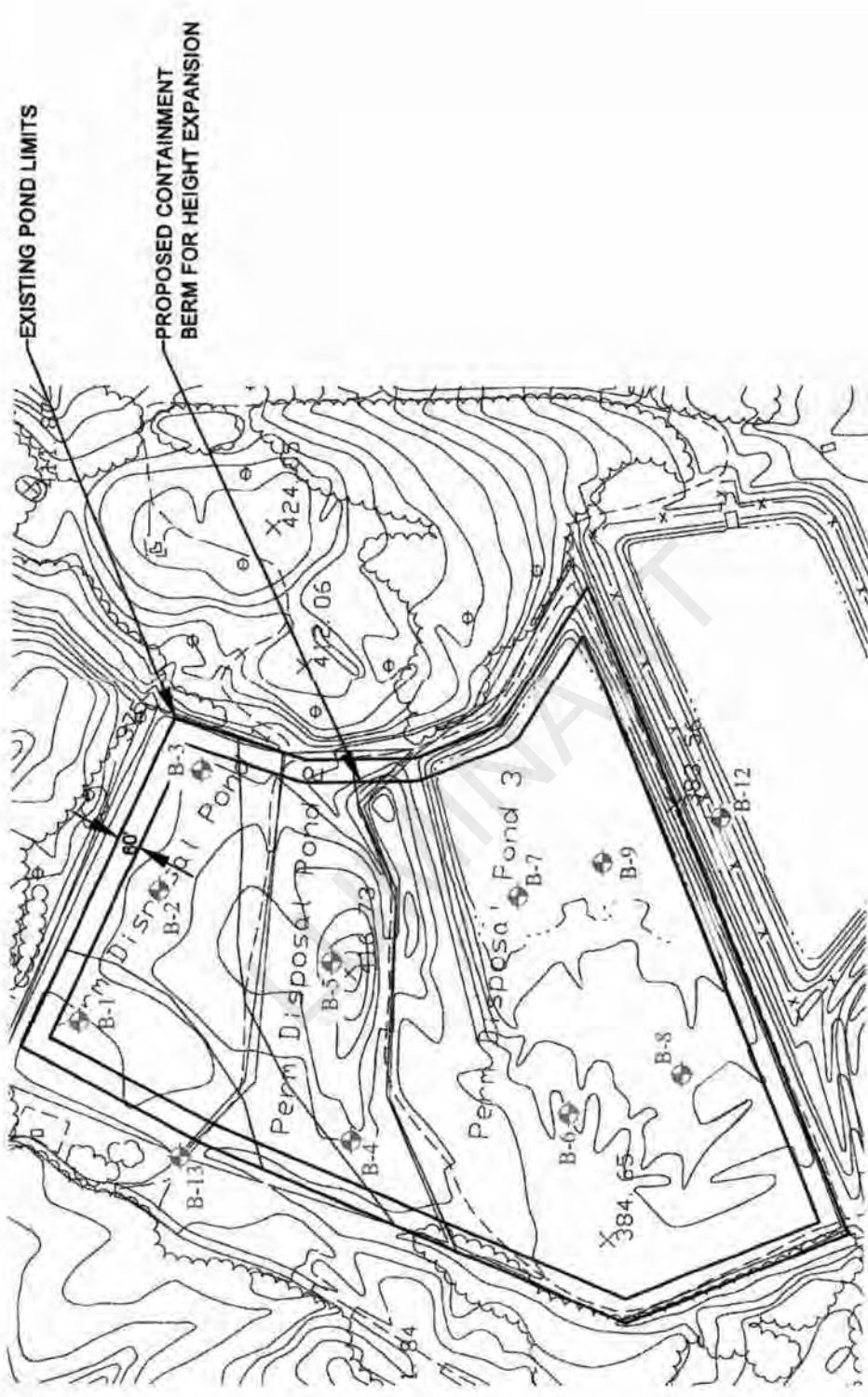

 ETTL ENGINEERS & CONSULTANTS <small>1000 West 10th Street Suite 200 Fort Worth, TX 76102</small>	LUMINANT MARTIN LAKE PDP 1-3 TATUM, TEXAS	PLATE 1 - PLAN OF BORINGS	APPROVED BY:
	DATE: MARCH 2008	SCALE: N.T.S.	DRAIN BY: K.C.R.



**ETTL
ENGINEERS &
CONSULTANTS**

MAIN OFFICE
1717 East Erwin
Tyler, Texas 75702
(803) 505-4421

MATERIAL DESCRIPTION

SILTY SAND(SM) loose; tan; moist; with ferric oxide; with organics
ASH SEDIMENT medium dense; black and gray; coarse to very fine-grained sand
-black
-loose; black and gray; coarse to very fine-grained sand

Bottom of Boring @ 20'

Water Level
Water Column of 1' and caved to 6' on 2/29/08.
Est. Measured: Permet:
Seepage @ 7' while drilling. Water level @ 1' and caved to 6' on 2/29/08.

LOG OF BORING B-1													
PROJECT: Luminant Martin Lake PDP 1-3 Tatum, Texas					DATE: 2/22/08								
PROJECT NO.: G 2810-08					SURFACE ELEVATION: 390'								
BORING TYPE: Flight Augur					OTHER TESTS (Page Ref. #)								
FIELD STRENGTH DATA	BLOW COUNT	Cu (tsf)	PPR (tsf)	Torque (tsf)	DRY DENSITY (pcf)	COMPRESSIVE STRENGTH (psi)	FAILURE STRAIN (%)	CONFINING PRESSURE (ps)	ATTERBERG LIMITS (%)				
									LIQUID LIMIT (LL)	PLASTIC LIMIT (PL)	PLASTICITY INDEX (PI)		
N=5	1	1.0	2.0	3.0	101				17	14	2	34	+40 Sieve = 8%, +4 Sieve = 3%
N=22	2	2.0	3.0	4.0	82				23	14	2	23	+40 Sieve = 55%, +4 Sieve = 25%
N=17	3	3.0	4.0	4.0					28	14	2	23	
N=0	4	4.0	4.0	4.0					36	14	2	23	
N=9	5	4.0	4.0	4.0					32	14	2	53	

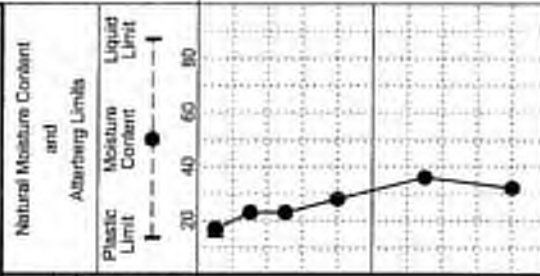

Note:
GPS Coordinates: N 32°15.790', W 94°34.996'. Minus #200 Sieve (53%) @ 18' (Hydrometer - Specific Gravity 2.608). Dry Density (82) @ 8' (Hydraulic Conductivity K=2.79E-04 cm/sec).

Key to Abbreviations:
N - SPT Data (Blow/T)
P - Pycnometer (pcf)
T - Torque (tsf)
L - Lab Vane Shear (psi)



**ETTL
ENGINEERS &
CONSULTANTS**

MAIN OFFICE
1717 East Erwin
Tyler, Texas 75702
(903) 595-4421

LOG OF BORING B-12

PROJECT: Luminant Martin Lake PDP 1-3
Tatum, Texas

PROJECT NO.: G 2810-08

BORING TYPE: Rotary Wash

DATE: 2/27/08

SURFACE ELEVATION: 380'

MOISTURE CONTENT (%)

LIQUID LIMIT

PLASTIC LIMIT

PLASTICITY INDEX

MINUS #200 SIEVE (%)

OTHER TESTS PERFORMED (Page Ref. #)

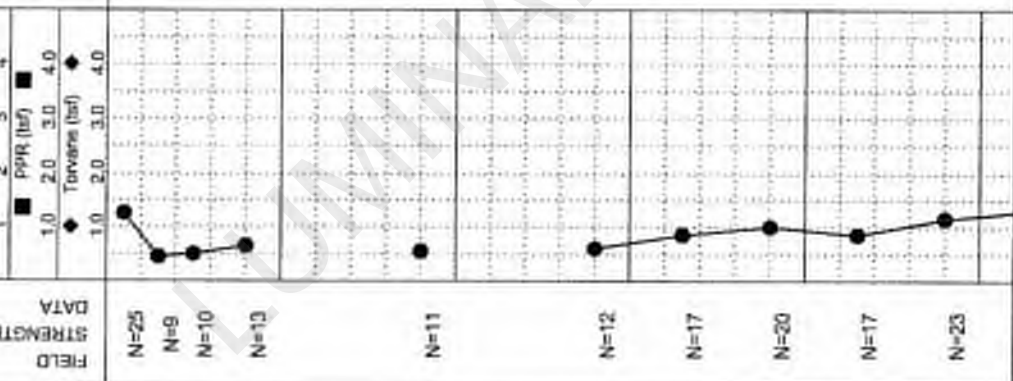
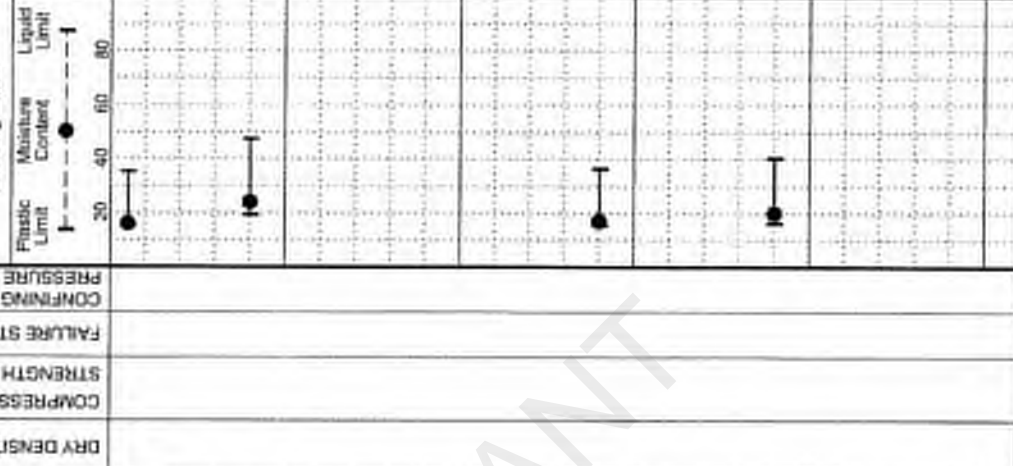

FIELD STRENGTH DATA	COMPRESSIVE STRENGTH (psi)	FAILURE STRAIN (%)	CONFINING PRESSURE (psi)	DRY DENSITY (pcf)
N=25				
N=9				
N=10				
N=13				
N=11				
N=12				
N=17				
N=20				
N=17				
N=23				

MATERIAL DESCRIPTION

CLAYEY SAND(S) medium dense; red and orange
 -blue, gray, red, and orange
 LEAN CLAY WITH SAND(CL) stiff; red, orange, and tan
 -gray and red
 -red and orange
 CLAYEY SAND(S) medium dense; red and orange
 -with iron oxide cemented sandstone gravel
 SILTY SAND(SM) medium dense; gray, red, and orange
 SANDY LEAN CLAY(CL) medium dense; red, orange, and gray
 -red and orange; with iron oxide cemented sandstone s.s. @ 45'
 SILTY SAND(SM) medium dense; gray, orange, and tan

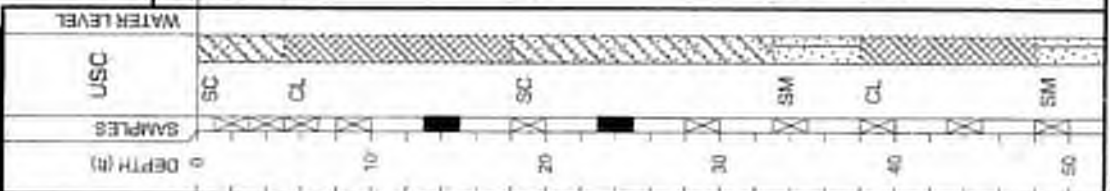

Water Level: Measured: Precip:
 Water Observations: Dry and open to 25' on 2/29/08.
 GPS Coordinates: N 32°15.513', W 94°34.904'.
 Notes:
 Key to Abbreviations:
 N - SPT Data (Blows/F)
 P - Proctor Parameters (Pf)
 T - Torsion (Tf)
 L - Lab Vane Shear (Vs)



**ETTL
ENGINEERS &
CONSULTANTS**

MAIN OFFICE
1717 East Erwin
Tyler, Texas 75702
(800) 680-4421

MATERIAL DESCRIPTION

-gray, red, brown
-gray and brown
SILT(ML) dense; brown and gray
-very dense
LEAN CLAY WITH SAND(CL) hard, gray
SILT(ML) very dense gray

Bottom of Boring @ 100'

WATER LEVEL
USC
SAMPLES
DEPTH (ft)

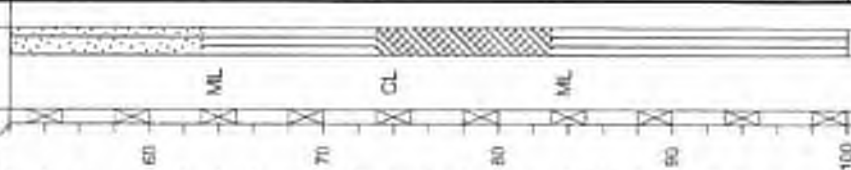

Water Level
Water County etc.
E-1: Measured: Predicted:
Dry and open to 25' on 2/23/08.

LOG OF BORING B-12											
PROJECT: Luminant Marlin Lake PDP 1-3 Tatum, Texas					DATE: 2/27/08						
PROJECT NO.: G 2810-08					SURFACE ELEVATION: 380'						
BORING TYPE: Rotary Wash					OTHER TESTS PERFORMED (Page Ref. #)						
FIELD STRENGTH DATA	BLOW COUNT	DRY DENSITY (pcf)	COMPRESSIVE STRENGTH (ksf)	FAILURE STRAIN (%)	CONFINING PRESSURE (psi)	Natural Moisture Content and Atterberg Limits			MINUS #200 SIEVE (%)		
						Plastic Limit	Moisture Constant	Liquid Limit			
▲	▲	▲	▲	▲	▲	PL	PL	PL	PL		
■	■	■	■	■	■	LL	LL	LL	LL		
◆	◆	◆	◆	◆	◆	PL	PL	PL	PL		
◆	◆	◆	◆	◆	◆	LL	LL	LL	LL		
N=25	1.0	99				25	45	24	21	96	+40 Sieve =2%, +4 Sieve =0%
N=28	1.0										
N=46	2.0										
N=66	3.0										
N=50/3	3.0	102									
N=50/4	3.0										+40 Sieve =24%, +4 Sieve =23%
N=71	3.0										
N=50/5	3.0	107									+40 Sieve =2%, +4 Sieve =0%
N=70	3.0										
N=80	3.0										

Notes:
GPS Coordinates: N 32°15.513', W 94°34.904'



**ETTL
ENGINEERS &
CONSULTANTS**

MAIN OFFICE
1717 East Erwin
Tyler, Texas 75702
(800) 596-4421

MATERIAL DESCRIPTION

CLAYEY SAND(SC) medium dense; red

-brown and gray

-dense; red and tan

-tan, red, and gray

FAT CLAY(CH) silt; red, gray, and tan

-with iron laminations

LEAN CLAY(CL) very silt; gray

-hard

-gray and brown; with iron oxide cemented sandstone seams

SANDY SILT(ML) very dense; gray; with clay seams

DEPTH (ft)

0

10

20

30

40

50

SAMPLES

USC

WATER LEVEL

▲

SC

CH

CL

ML

Water Level

Water Circulation

Seepage @ 29' while drilling. Water level @ 28' and open upon completion. Water level @ 12' and caved to 14' on 2/29/08.

Est. Measured Perched

LOG OF BORING B-13

PROJECT: Luminant Martin Lake PDP 1-3
Tatum, Texas

PROJECT NO.: G 2010-06

BORING TYPE: Rotary Wash

DATE

2/19/08

SURFACE ELEVATION
380'

FIELD STRENGTH	DATA				DRY DENSITY (pcf)	COMPRESSIVE STRENGTH (psf)	FAILURE STRAIN (%)	CONFINING PRESSURE (psf)	Natural Moisture Content and Atterberg Limits			MOISTURE CONTENT (%)	LIQUID LIMIT (LL)	PLASTIC LIMIT (PL)	PLASTICITY INDEX (PI)	MINUS #200 SIEVE (%)	OTHER TESTS PERFORMED (Page Ref. #)
	Blow Count	Cu (pcf)	PPR (pcf)	Tw (pcf)					Plastic Limit	Moisture Content	Liquid Limit						
N=11	1	1.0	1.0	1.0					20	14	24	10	46		+40 Sieve =3%, +4 Sieve =1%		
N=16	2	2.0	2.0	2.0					20	23	51	31	89		+40 Sieve =7%, +4 Sieve =1%		
N=36	3	3.0	3.0	3.0					20	23	48	27	94		+40 Sieve =2%, +4 Sieve =0%		
N=47	4	4.0	4.0	4.0					20	26			66		+40 Sieve =2%, +4 Sieve =0%		
N=37																	
P=1.5																	
P=1.5																	
N=26																	
P=4.5+																	
P=4.5+																	
N=63																	
N=63																	

Notes

- N - SPT Data (Blow/Ft)
- P - Posttest Penetration (MP)
- T - Terence (pcf)
- L - Lab Vane Shear (psf)

Notes

GPS Coordinates: N 32°15.752', W 94°35.072'



**ETTL
ENGINEERS &
CONSULTANTS**

MAIN OFFICE
1717 East Erwin
Tyler, Texas 75702
(903) 595-4421

MATERIAL DESCRIPTION

-hard; laminated with sand seams
-very stiff; gray and green; with sand seams
LEAN CLAY (CL) hard; gray; laminated with sand seams
SILTY SAND (SM) very dense; gray
SILT (ML) very dense; gray
-with clay seams

Bottom of Boring @ 100'

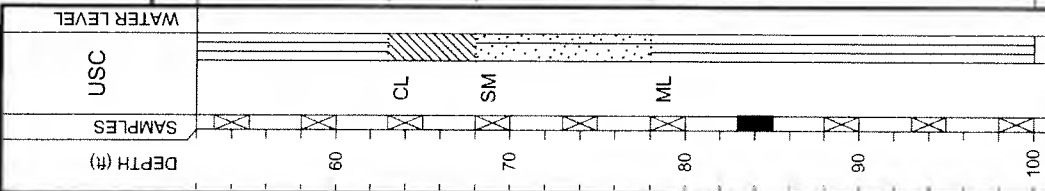

Water Level
Water Observations:
Seepage @ 23' while drilling. Water level @ 28' and open upon completion. Water level @ 12' and caved to 14' on 2/29/08.

Key to Abbreviations:
N - SPT Data (Blows/ft)
P - Picket Penetration (psf)
T - Torque (psf)
L - Lab Vane Shear (psf)

LOG OF BORING B-13									
PROJECT: Luminant Martin Lake PDP 1-3 Tatum, Texas					DATE: 2/19/08				
PROJECT NO.: G 2810-08					SURFACE ELEVATION: 380'				
BORING TYPE: Rotary Wash					OTHER TESTS PERFORMED (Page Ref. #)				
FIELD STRENGTH	DRY DENSITY (pcf)	COMPRESSIVE STRENGTH (ksf)	FAILURE STRAIN (%)	CONFINING PRESSURE (psf)	Natural Moisture Content and Atterberg Limits			MINUS #200 SIEVE (%)	MOISTURE CONTENT (%)
					Plastic Limit	Moisture Content	Liquid Limit		
BLOW COUNT	Qu (tsf)	PPR (ksf)	Torque (ksf)	LL	PL	PI	LI	PL	PI
P=4.5									
P=2.5									
N=78									
N=75									
N=50/3.5									
N=78									
P=5F									
N=50/5									
N=50/3									
N=50/4									

Notes:
GPS Coordinates: N 32°15.752', W 94°35.072'



**ETTL
ENGINEERS &
CONSULTANTS**

MAIN OFFICE
1717 East Erwin
Tyler, Texas 75702
(903) 565-4421

MATERIAL DESCRIPTION

SANDY FAT CLAY(CH) stiff, red and orange
-with sand
ASH SEDIMENT medium dense, black
-very loose, with organic odor
-light gray
Bottom of Boring @ 25'

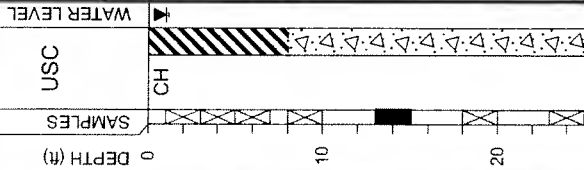

LOG OF BORING B-2

PROJECT: Luminant Martin Lake PDP 1-3
Tatum, Texas

PROJECT NO.: G 2810-08

BORING TYPE: Flight Auger

DATE

2/22/08

SURFACE ELEVATION
390'

FIELD STRENGTH DATA	BLOW COUNT ● 20 40 60 80 ▲ Cu (tsf) ▲ 1 2 3 4 ■ PPR (tsf) ■ 1.0 2.0 3.0 4.0 ◆ Torvane (tsf) ◆ 1.0 2.0 3.0 4.0	DRY DENSITY (pcf)	COMPRESSIVE STRENGTH (ksf)	FAILURE STRAIN (%)	CONFINING PRESSURE (psf)	ATTERBERG LIMITS (%)			MINUS #200 SIEVE (%)	OTHER TESTS PERFORMED (Page Ref. #)
						LIQUID LIMIT LL	PLASTIC LIMIT PL	PLASTICITY INDEX PI		
N=11	● 20 40 60 80 ▲ Cu (tsf) ▲ 1 2 3 4 ■ PPR (tsf) ■ 1.0 2.0 3.0 4.0 ◆ Torvane (tsf) ◆ 1.0 2.0 3.0 4.0					22	51	18	33	+40 Sieve =9%, +4 Sieve =6%
N=11						23	57	17	40	+40 Sieve =2%, +4 Sieve =0%, +40 Sieve =63%, +4 Sieve =40%
N=12						28	57	17	40	
N=11						29				
N=3						30				+40 Sieve =36%, +4 Sieve =12%
						42				

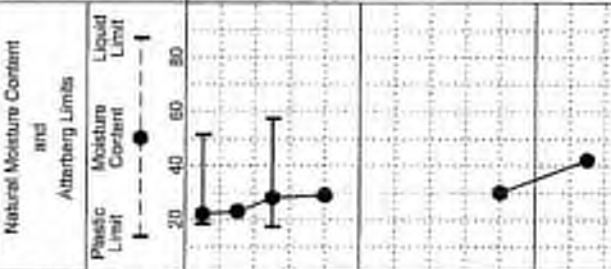

Notes:
GPS Coordinates: N 32°15.764', W 94°34.903'. Minus #200 Sieve (93%) @ 23' (Hydrometer - Specific Gravity 2.675).
Key to Abbreviations:
N - SPT Data (Blow/TI)
P - Pocket Penetrometer (psf)
T - Torvane (tsf)
L - Lab Vane Shear (tsf)



**ETTL
ENGINEERS &
CONSULTANTS**

MAIN OFFICE
1717 East Edwin
Tyler, Texas 75702
(803) 595-4421

MATERIAL DESCRIPTION

WATER LEVEL **7**

USC

SAMPLES

DEPTH (ft) 0 10 20 30

CH

SANDY FAT CLAY(CH) medium stiff, red and orange
-stiff

ASH SEDIMENT dense; black

-medium dense; black and gray, coarse-grained sand

-very loose; black; coarse to fine-grained sand

-no recovery

-loose; light gray

-medium dense; black; with organic odor

Bottom of Boring @ 30'

LOG OF BORING B-3													
PROJECT: Luminant Martin Lake PDP 1-3 Tatum, Texas					DATE: 2/22/08								
PROJECT NO.: G 2810-08					SURFACE ELEVATION: 390'								
BORING TYPE: Flight Auger					OTHER TESTS PERFORMED (Page Ref. #)								
FIELD STRENGTH DATA	BLOW COUNT ▲ Cu (blf) ▲ ■ PPR (blf) ■ ◆ Torque (blf) ◆	DRY DENSITY (pcf)	COMPRESSIVE STRENGTH (ksf)	FAILURE STRAIN (%)	CONFINING PRESSURE (psf)	Atterberg Limits and Natural Moisture Content			MOISTURE CONTENT (%)	LIQUID LIMIT (LL)	PLASTIC LIMIT (PL)	PLASTICITY INDEX (PI)	MINUS #200 SIEVE (%)
						Plastic Limit	Moisture Content	Liquid Limit					
N=10	1.0, 2.0, 3.0, 4.0	1.0, 2.0, 3.0, 4.0				21	54	19	35	89	+40 Sieve =5%, +4 Sieve =1%		
N=15	1.0, 2.0, 3.0, 4.0	1.0, 2.0, 3.0, 4.0				26	26	26	10	+40 Sieve =80%, +4 Sieve =10%			
N=42	1.0, 2.0, 3.0, 4.0	1.0, 2.0, 3.0, 4.0				28	28	28	9	+40 Sieve =67%, +4 Sieve =35%			
N=20	1.0, 2.0, 3.0, 4.0	1.0, 2.0, 3.0, 4.0				89	49	41	0	100	+40 Sieve =0%, +4 Sieve =0%		
N=4	1.0, 2.0, 3.0, 4.0	1.0, 2.0, 3.0, 4.0											
N=5	1.0, 2.0, 3.0, 4.0	1.0, 2.0, 3.0, 4.0											
N=21	1.0, 2.0, 3.0, 4.0	1.0, 2.0, 3.0, 4.0											

Key to Abbreviations:
N - SPT Data (Blows/Ft)
P - Pocket Penetrometer (blf)
T - Torque (blf)
L - Lab Vane Shear (blf)

Notes:

GPS Coordinates: N 32°15.746', W 94°34.855'. Minus #200 Sieve (42%) @ 5' (Hydrometer - Specific Gravity 2.561).

Water Level **7**

Water Characteristics: Seepage @ 8' while drilling. Water level @ 2' and caved to 8' on 2/29/08.



**ETTL
ENGINEERS &
CONSULTANTS**

MAIN OFFICE
1717 East Erwin
Tyler, Texas 75702
(936) 505-4421

MATERIAL DESCRIPTION

SILTY CLAYEY SAND(SC-SM) medium dense;
red and brown
-very stiff, red and orange
SILTY SAND(SM) medium dense; red and tan
LEAN CLAY(CL) very stiff; red, orange, and tan

-red, tan, and grey

Bottom of Boring @ 20'

WATER LEVEL
USC
SAMPLES
DEPTH (ft)

0
10
20

SC
SM
SM
CL

▲ WATER LEVEL

LOG OF BORING B-4

PROJECT: Luminant Martin Lake PDP 1-3
Tatum, Texas

PROJECT NO.: G 2510-08

BORING TYPE: Flight Auger

DATE

2/22/08

SURFACE ELEVATION
385'

MOISTURE CONTENT (%)

LIQUID LIMIT

PLASTIC LIMIT

PLASTICITY INDEX

MINUS #200 SIEVE (%)

OTHER TESTS
PERFORMED
(Page Ref. #)

15

20

14

6

42

+40 Sieve =1%
+4 Sieve =0%

18

35

16

17

85

+40 Sieve =5%
+4 Sieve =1%

22

21

39

21

18

51

+40 Sieve =0%
+4 Sieve =0%

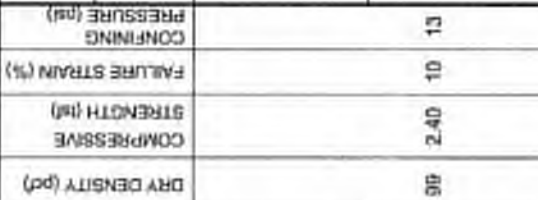
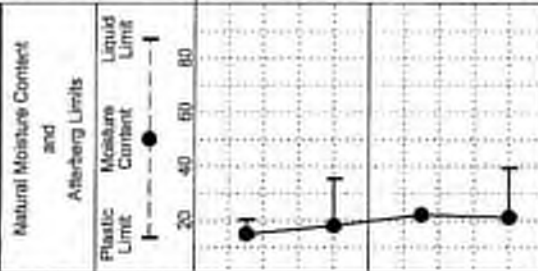

FIELD STRENGTH	DRY DENSITY (pcf)	COMPRESSION STRENGTH (psi)	FAILURE STRAIN (%)	CONFINING PRESSURE (psi)
N=14	98	2.40	10	13
N=21				
N=22				
N=18				
P=3.5				
N=25				

DATA	BLOW COUNT	Cu (tsf)	PPR (tsf)	Torvane (tsf)
N=14	20	1.0	2.0	3.0
N=21	25	1.0	2.0	3.0
N=22	30	1.0	2.0	3.0
N=18	35	1.0	2.0	3.0
P=3.5	40	1.0	2.0	3.0
N=25	45	1.0	2.0	3.0

FIELD STRENGTH	DRY DENSITY (pcf)	COMPRESSION STRENGTH (psi)	FAILURE STRAIN (%)	CONFINING PRESSURE (psi)
N=14	98	2.40	10	13
N=21				
N=22				
N=18				
P=3.5				
N=25				

DATA	BLOW COUNT	Cu (tsf)	PPR (tsf)	Torvane (tsf)
N=14	20	1.0	2.0	3.0
N=21	25	1.0	2.0	3.0
N=22	30	1.0	2.0	3.0
N=18	35	1.0	2.0	3.0
P=3.5	40	1.0	2.0	3.0
N=25	45	1.0	2.0	3.0

FIELD STRENGTH	DRY DENSITY (pcf)	COMPRESSION STRENGTH (psi)	FAILURE STRAIN (%)	CONFINING PRESSURE (psi)
N=14	98	2.40	10	13
N=21				
N=22				
N=18				
P=3.5				
N=25				

Notes:
GPS Coordinates: N 32° 15.675', W 94° 35.083'

Key to Abbreviations:
N - SPT Data (Blows/ft)
P - Pocket Penetrometer (tsf)
T - Torvane (tsf)
L - Lull Vane Shear (tsf)

Water Level
Water Characteristics
Surface and cased to 15' on 2/29/08.

Est. Measured: Perched:
Seepage @ 3' while drilling. Water level @
Surface and cased to 15' on 2/29/08.



**ETTL
ENGINEERS &
CONSULTANTS**

MAIN OFFICE
1717 East Erwin
Tyler, Texas 75702
(903) 595-4421

MATERIAL DESCRIPTION

FAT CLAY WITH SAND(CH) medium stiff, red, orange, and gray
-soft
SANDY LEAN CLAY(CL) medium stiff, red and orange
FAT CLAY WITH SAND(CH) very stiff, red and orange
ASH SEDIMENT medium dense; gray and black
-loose
-medium dense
-loose
-gray
-very loose
-loose

Bottom of Boring @ 45'

Est: Measured Perched
Water level @ 23' and caved to 26' on

Water Level
Water Observed on:
2/29/08

LOG OF BORING B-5													
PROJECT: Luminant Martin Lake PDP 1-3 Tatum, Texas					DATE: 2/22/08								
PROJECT NO.: G 2610-08					SURFACE ELEVATION: 415'								
BORING TYPE: Flight Auger													
FIELD STRENGTH DATA	BLOW COUNT		DRY DENSITY (pcf)		COMPRESSION STRENGTH (psi)	FAILURE STRAIN (%)	CONFINING PRESSURE (psi)	Natural Moisture Content and Atterberg Limits			MINUS #200 SIEVE (%)	OTHER TESTS PERFORMED (Page Ref. #)	
	N	1	2	3				4	PL	PI			LI
N=6	1.0	2.0	3.0	4.0	62			23	51	16	35	77	+40 Sieve =4%, +4 Sieve =1%
N=4	1.0	2.0	3.0	4.0				17	26	14	14	60	+40 Sieve =6%, +4 Sieve =1%
N=6	1.0	2.0	3.0	4.0				23	52	17	35	77	+40 Sieve =4%, +4 Sieve =1%
N=23	1.0	2.0	3.0	4.0				25				16	+40 Sieve =54%, +4 Sieve =24%
N=23	1.0	2.0	3.0	4.0				34				32	+40 Sieve =37%, +4 Sieve =16%
N=7	1.0	2.0	3.0	4.0									
N=15	1.0	2.0	3.0	4.0									
N=8	1.0	2.0	3.0	4.0									
N=5	1.0	2.0	3.0	4.0									
N=4	1.0	2.0	3.0	4.0									
N=7	1.0	2.0	3.0	4.0									

Notes:
GPS Coordinates: N 32°15.667', W 94°34.936'

Key to Abbreviations:
N - SPT Data (Blows/Ft)
P - Pocket Penetrometer (psi)
T - Torvane (psi)
L - Lab Vane Shear (psi)



**ETTL
ENGINEERS &
CONSULTANTS**

MAIN OFFICE
1717 East Erwin
Tyler, Texas 75702
(903) 595-4421

MATERIAL DESCRIPTION

ASH SEDIMENT medium dense; black and tan
 SANDY LEAN CLAY (CL) stiff; red and tan
 -very stiff
 ASH SEDIMENT loose; black
 -medium dense
 Bottom of Boring @ 20'

WATER LEVEL
 USC
 SAMPLES
 0 DEPTH (ft)

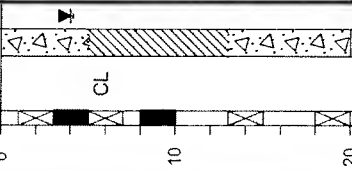

LOG OF BORING B-6

PROJECT: Luminant Martin Lake PDP 1-3
Tatum, Texas

PROJECT NO.: G 2610-08

BORING TYPE: Flight Auger

DATE

2/22/08

SURFACE ELEVATION
385'

MOISTURE CONTENT (%)	ATTERBERG LIMITS (%)			MINUS #200 SIEVE (%)	OTHER TESTS PERFORMED (Page Ref. #)
	LIQUID LIMIT (LL)	PLASTIC LIMIT (PL)	PLASTICITY INDEX (PI)		
26	35	19	16	44	+40 Sieve =30%, +4 Sieve =13%
22	35	19	16	61	+40 Sieve =7%, +4 Sieve =4%
40				61	+40 Sieve =5%, +4 Sieve =2%
68				84	

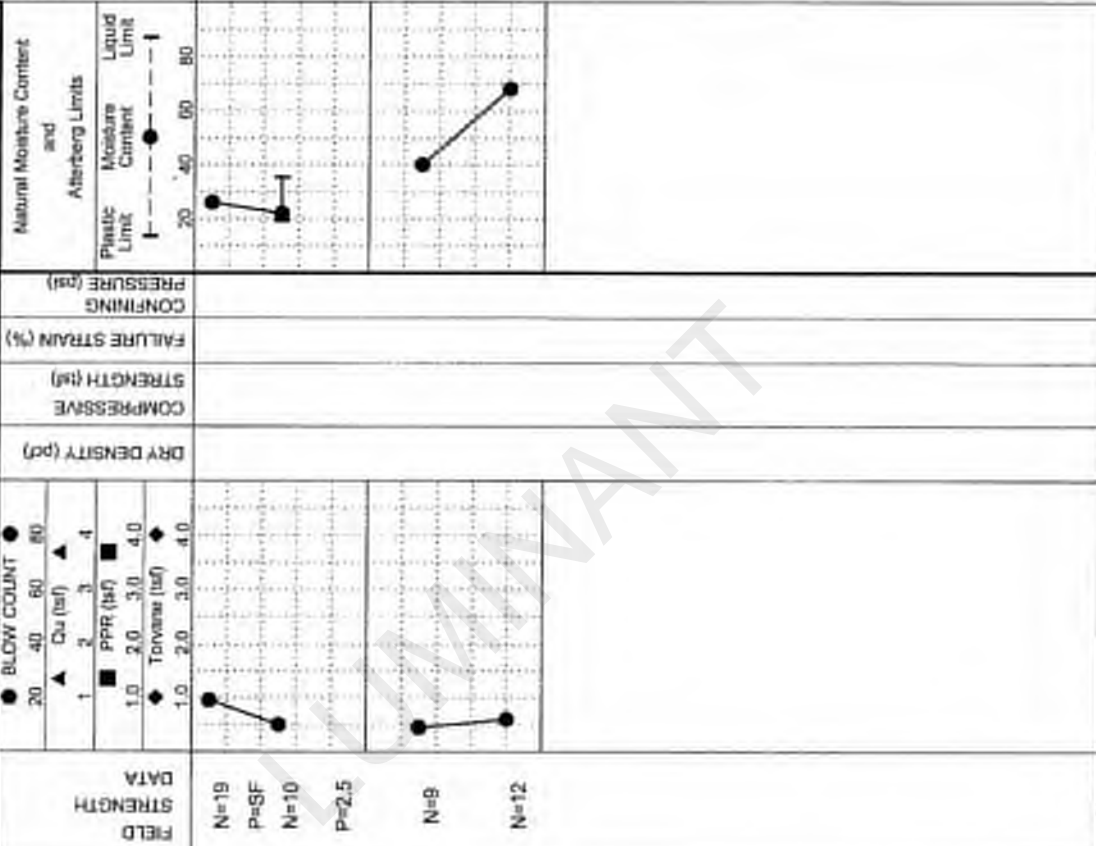

FIELD STRENGTH	BLOW COUNT	DRY DENSITY (pcf)	COMPRESSIVE STRENGTH (ksf)	FAILURE STRAIN (%)	CONFINING PRESSURE (psf)	Natural Moisture Content and Atterberg Limits
N=19	1.0, 2.0, 3.0, 4.0					
P=SF						
N=10	1.0, 2.0, 3.0, 4.0					
P=2.5						
N=9						
N=12						

Key to Abbreviations
 N - SPT Data (Blows/ft)
 P - Pocket Parallels/ft
 T - Torvane (pcf)
 L - Lab Vane Shear (ksf)

Water Level
 Water Controlling:
 Seepage @ 4' while drilling. Water level @ 4' and caved to 7' upon completion. Water level @ 1' and caved to 8' on 2/29/08.
 Est. Measured: Perched:

Note:
 GPS Coordinates: N 32°15.591', W 94°35.088', Minus #200 Sieve (84) @ 15' (Hydrometer - Specific Gravity 2.732).



**ETTL
ENGINEERS &
CONSULTANTS**

MAIN OFFICE
1717 East Erwin
Tyler, Texas 75702
(803) 595-4421

MATERIAL DESCRIPTION

ASH SEDIMENT medium dense; black
-dense; black

-loose

-very loose

LEAN CLAY WITH SAND (CL) medium stiff;
orange and black

-tan and red

-medium dense; red and orange

SANDY FAT CLAY (CH) medium dense; red and
orange

Bottom of Boring @ 40'

WATER LEVEL

USC
SAMPLES
DEPTH (ft)

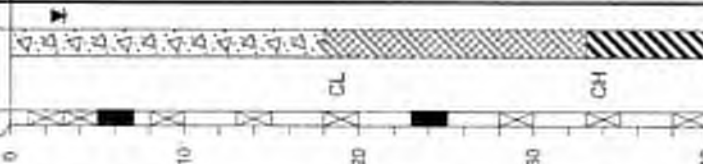

Water Level
Water Closed at:
2/29/08

Est. Measure: Permet
Water level @ 3' and caved to 24' on

LOG OF BORING B-7

PROJECT: Luminant Martin Lake PDP 1-3
Tatum, Texas

PROJECT NO.: G 2810-08

BORING TYPE: Rotary Wash

DATE

2/29/08

SURFACE ELEVATION
390'

FIELD STRENGTH DATA	BLOWY COUNT ▲ Cu (blf) ▲ ■ PPR (blf) ■ ◆ Torvane (blf) ◆	DRY DENSITY (pcf)	COMPRESSION STRENGTH (blf)	FAILURE STRAIN (%)	CONFINING PRESSURE (psf)	Atterberg Limits		MOISTURE CONTENT (%)	ATTERBERG LIMITS (%)			OTHER TESTS PERFORMED (Page Ref. #)
						Plastic Limit	Liquid Limit		LIQUID LIMIT	PLASTIC LIMIT	PLASTICITY INDEX	
N=13	1.0 2.0 3.0 4.0	98	2.30	2	6	20	40	37	LL	PL	PI	+40 Sieve =10%, +4 Sieve =10%
N=40	1.0 2.0 3.0 4.0	98	2.30	2	6	20	40	23				
P=4,5	1.0 2.0 3.0 4.0	98	2.30	2	6	20	40	38				
N=7	1.0 2.0 3.0 4.0	98	2.30	2	6	20	40	38				
N=4	1.0 2.0 3.0 4.0	98	2.30	2	6	20	40	27	42	17	25	+40 Sieve =1%, +4 Sieve =10%
N=7	1.0 2.0 3.0 4.0	98	2.30	2	6	20	40	21				
N=22	1.0 2.0 3.0 4.0	104	0.50	13	22	20	40	27	53	20	33	+40 Sieve =27%, +4 Sieve =22%
N=23	1.0 2.0 3.0 4.0	104	0.50	13	22	20	40	27				
N=22	1.0 2.0 3.0 4.0	104	0.50	13	22	20	40	27				

Key to Abbreviations:
N - SPT Data (Blow/ft)
P - Pocket Penetrometer (blf)
T - Torvane (blf)
L - Lab Value (Shear (blf))

Note:

GPS Coordinates: N 32°15.646', W 94°34.870'. Minus #200 Sieve (11%) @ 13' (Hydrometer - Specific Gravity 2.655).



**ETTL
ENGINEERS &
CONSULTANTS**

MAIN OFFICE
1717 East Erwin
Tyler, Texas 75702
(903) 595-4421

MATERIAL DESCRIPTION

ASH SEDIMENT loose; gray
-very loose; gray and black
-medium dense; brown

-very loose; black

-strong odor

Bottom of boring @ 30'

USC
SAMPLES
DEPTH (ft)
0
10
20
30

WATER LEVEL

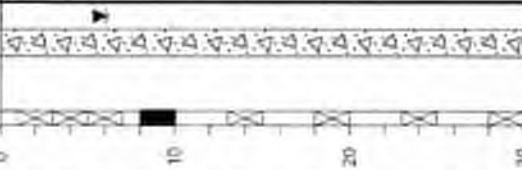

Water Level
Water Column Stone
Seepage @ 4' while drilling. Water level @ 6' and caved to 17' upon completion. Dry and caved to 3' and on 2/29/08.

Key to Abbreviations
N - SPT Data (Blows/ft)
P - Pocket Penetrometer (psf)
T - Torque (ft-lb)
L - Lab Vane Shear (psf)

LOG OF BORING B-8

PROJECT: Luminant Martin Lake PDP 1-3
Tatum, Texas

PROJECT NO.: G 2810-08

BORING TYPE: Flight Auger

DATE

2/20/08

SURFACE ELEVATION
390'

OTHER TESTS
PERFORMED
(Page Ref. #)

MINUS #200 SIEVE (%)

ATTERBERG LIMITS (%)

LIQUID LIMIT LL

PLASTIC LIMIT PL

PLASTICITY INDEX PI

MOISTURE CONTENT (%)

73

95

95

+40 Sieve = 3%,
+4 Sieve = 0%

72

95

+40 Sieve = 1%,
+4 Sieve = 0%

85

+40 Sieve = 0%,
+4 Sieve = 0%

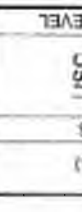
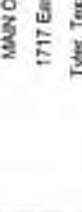
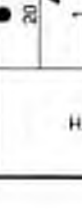
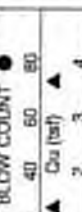
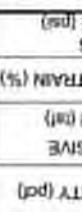
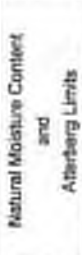

Notes:

GPS Coordinates: N 32°15.548', W 94°34.570'



**ETTL
ENGINEERS &
CONSULTANTS**

MAIN OFFICE
1717 East Erwin
Tyler, Texas 75702
(903) 685-4421

USC
SAMPLES

DEPTH (ft)

MATERIAL DESCRIPTION

ASH SEDIMENT, very loose, gray

-loose; black and gray

-medium dense

-very loose; black

-loose

-very loose

-gray and black; strong odor

Bottom of Boring @ 30'

WATER LEVEL

PERCENT



FIELD STRENGTH DATA

DRY DENSITY (pcf)
COMPRESSION STRENGTH (lb)
FAILURE STRAIN (%)
CONFINING PRESSURE (psi)

Plastic Limit
Moisture Content
Liquid Limit

Natural Moisture Content and Atterberg Limits

MOISTURE CONTENT (%)
LIQUID LIMIT
PLASTIC LIMIT
PLASTICITY INDEX

MINUS #200 SIEVE (%)
OTHER TESTS PERFORMED (Page Ref. #)

DATE: 2/20/08

SURFACE ELEVATION: 390'

PROJECT: Luminant Martin Lake PDP 1-3
Tatum, Texas

PROJECT NO.: G 2610-08

BORING TYPE: Flight Auger

LOG OF BORING B-9

Notes:
GPS Coordinates: N 32°15.556', W 94°34.913'. Minus #200 Sieve (89%) @ 1' (Hydrometer - Specific Gravity 2.761).
Key to Abbreviations:
N - SPT Data (Blows/ft)
P - Pocket Penetrometer (psi)
T - Torvane (pcf)
L - Lab Vane Shear (pcf)

Water Level: Seepage @ 4' while drilling. Water level @ 6' and caved to 18' upon completion. Dry and caved to 4' on 2/29/08



CPT Data

Job Number 04.1908-0020 CPT Number B-02 Location Tatum-Tx
 Operator GLENN JOHNSON Date and T 16-Apr-2008 13:47:38 Cone Number F7.5CKEW2/B 1866
 Client _____ Elevation _____ Water Table _____

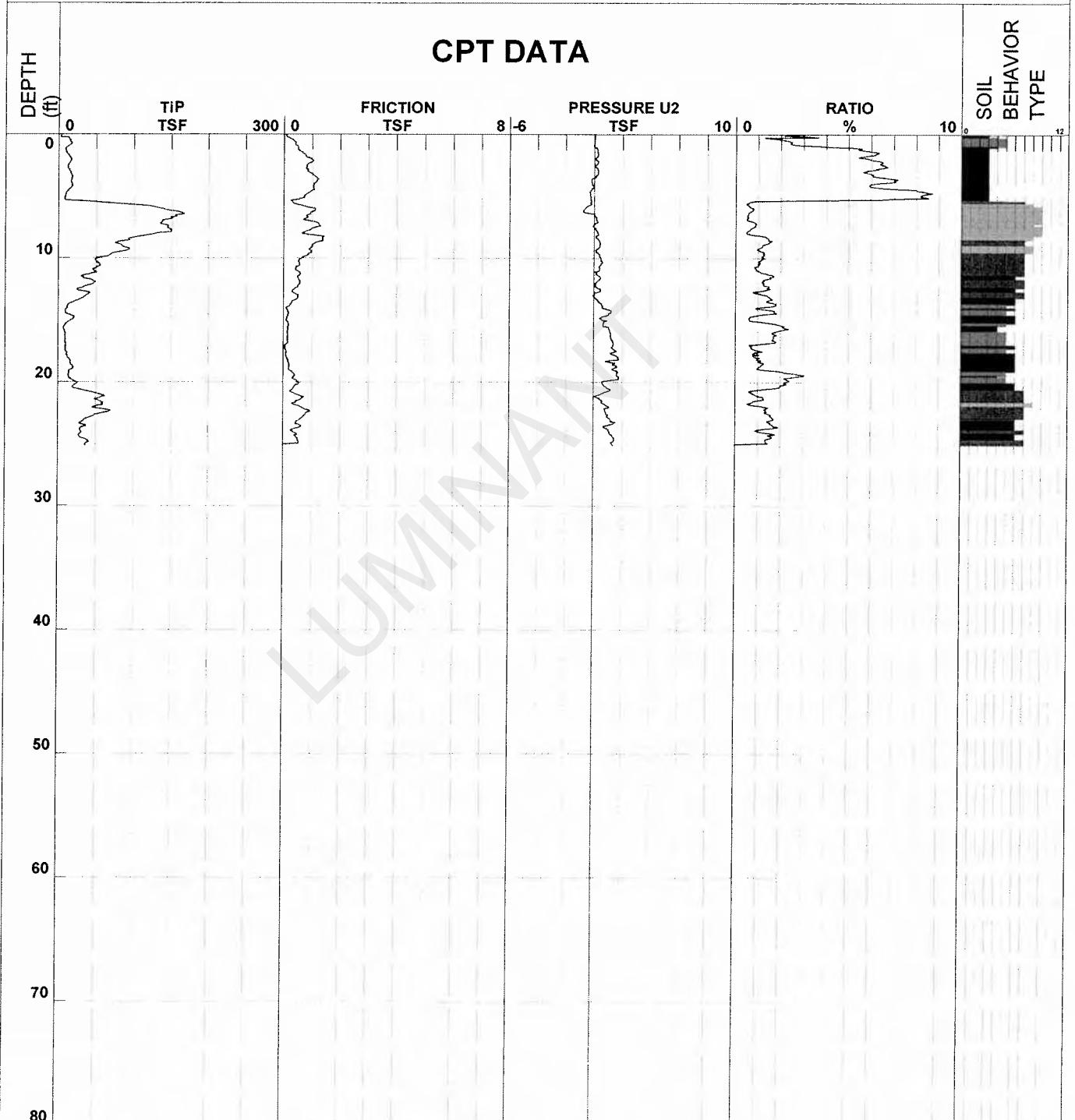

- | | | | |
|------------------------------|---------------------------------|--------------------------------|------------------------------------|
| ■ 1 - sensitive fine grained | ■ 4 - silty clay to clay | ■ 7 - silty sand to sandy silt | ■ 10 - gravelly sand to sand |
| ■ 2 - organic material | ■ 5 - clayey silt to silty clay | ■ 8 - sand to silty sand | ■ 11 - very stiff fine grained (*) |
| ■ 3 - clay | ■ 6 - sandy silt to clayey silt | ■ 9 - sand | ■ 12 - sand to clayey sand (*) |

Robertson et al. 1986 * Overconsolidated or Cemented



CPT Data

Job Number 04.1908-0020

CPT Number B-07

Location Tatum-Tx

Operator GLENN JOHNSON

Date and T 16-Apr-2008 12:40:51

Cone Number F7.5CKEW2/B 1866

Client _____

Elevation _____

Water Table _____

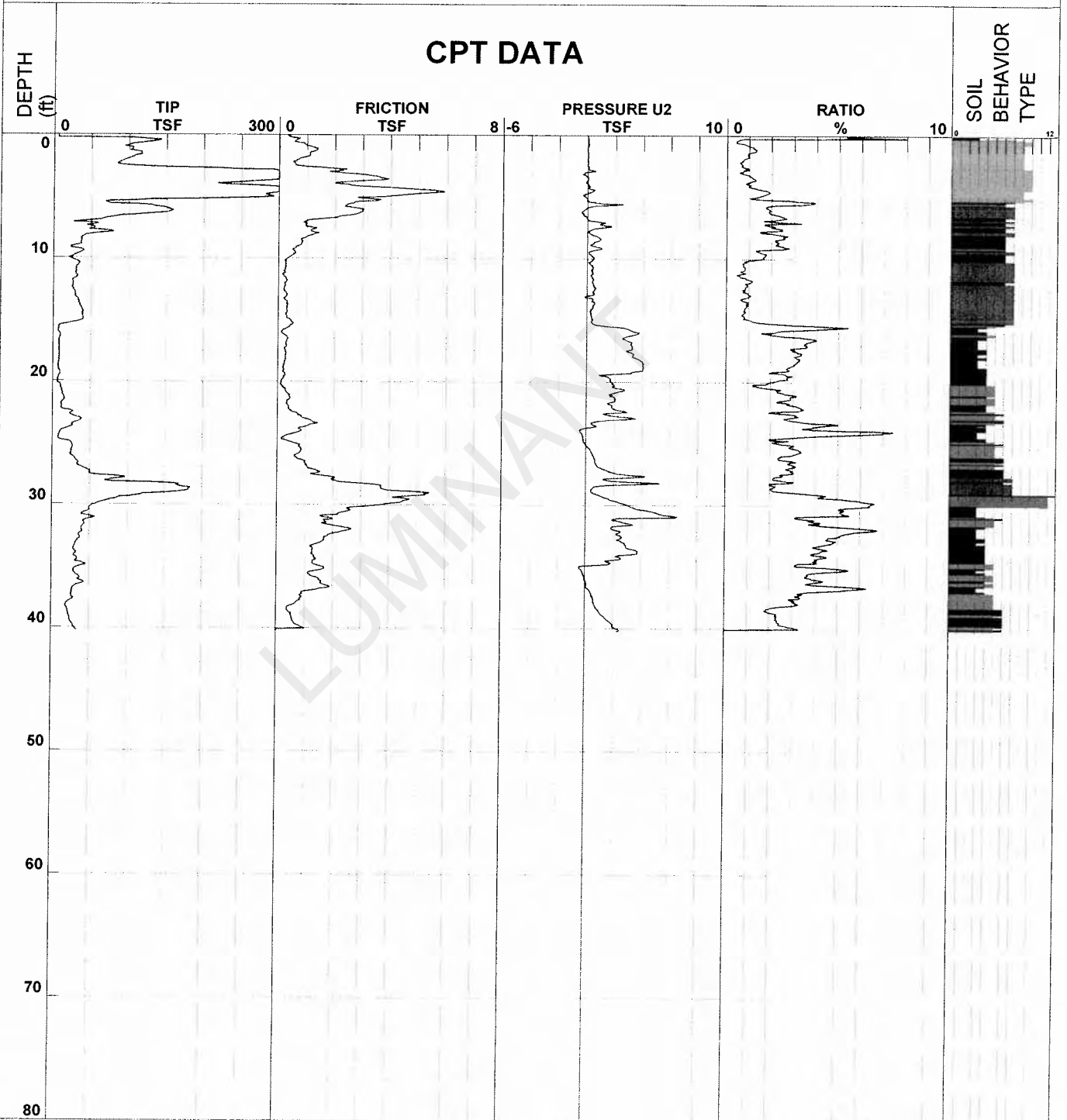

- | | | | |
|----------------------------|-------------------------------|------------------------------|----------------------------------|
| 1 - sensitive fine grained | 4 - silty clay to clay | 7 - silty sand to sandy silt | 10 - gravelly sand to sand |
| 2 - organic material | 5 - clayey silt to silty clay | 8 - sand to silty sand | 11 - very stiff fine grained (*) |
| 3 - clay | 6 - sandy silt to clayey silt | 9 - sand | 12 - sand to clayey sand (*) |

Robertson et al. 1986 * Overconsolidated or Cemented



CPT Data

Job Number 04.1908-0020

CPT Number B-12

Location Tatum-Tx

Operator GLENN JOHNSON

Date and T 16-Apr-2008 10:58:47

Cone Number F7.5CKEW2/B 1866

Client _____

Elevation _____

Water Table _____

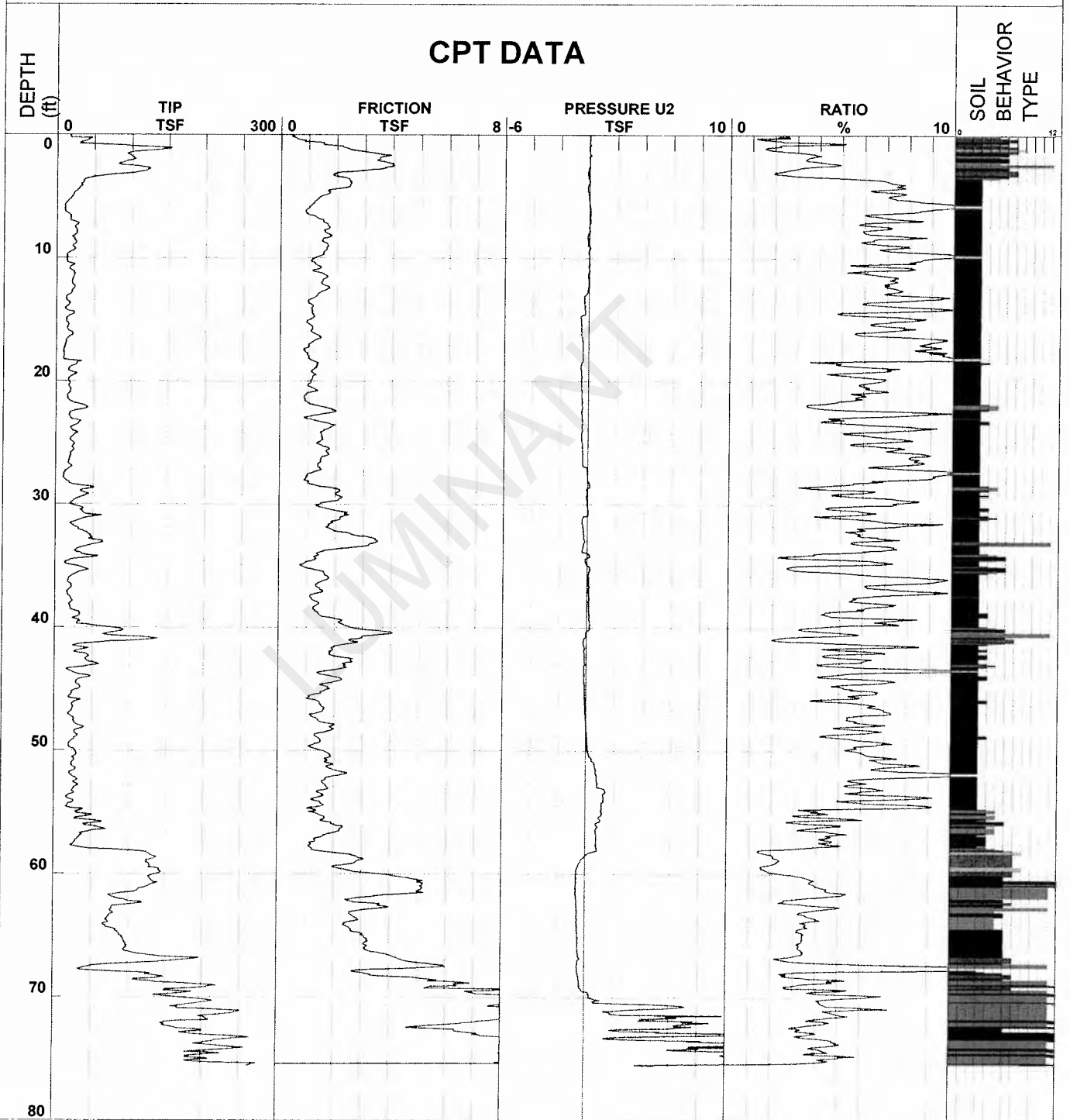

- | | | | |
|----------------------------|-------------------------------|------------------------------|----------------------------------|
| 1 - sensitive fine grained | 4 - silty clay to clay | 7 - silty sand to sandy silt | 10 - gravelly sand to sand |
| 2 - organic material | 5 - clayey silt to silty clay | 8 - sand to silty sand | 11 - very stiff fine grained (*) |
| 3 - clay | 6 - sandy silt to clayey silt | 9 - sand | 12 - sand to clayey sand (*) |

Robertson et al. 1986 * Overconsolidated or Cemented

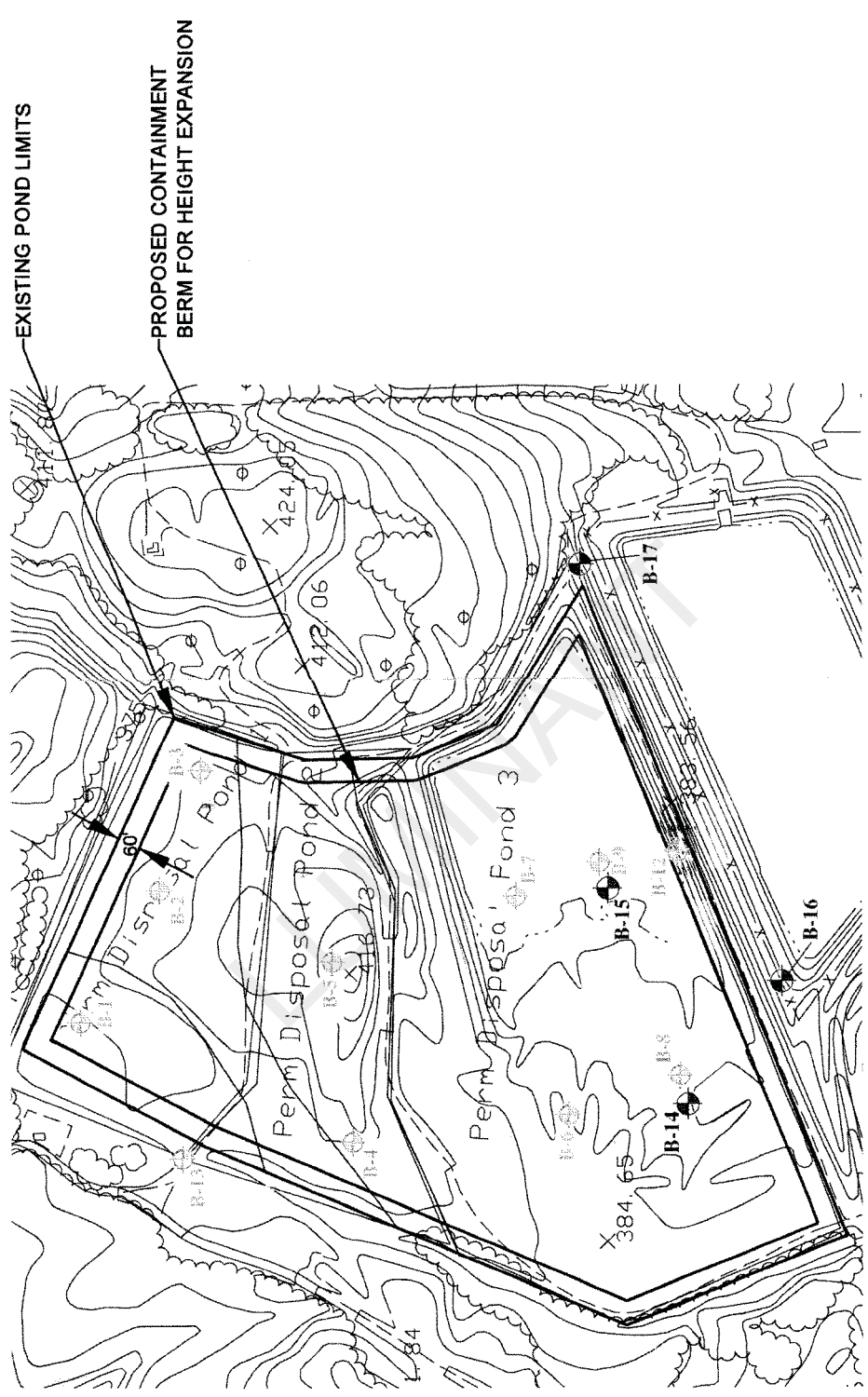

 E.T.T.L. ENGINEERS & CONSULTANTS <small>177 East 5th Fort Worth, TX 76102 (817) 336-4422</small>	LUMINANT MARTIN LAKE PDP 1-3 TATUM, TEXAS	PLATE 1 - PLAN OF BORINGS	APPROVED BY:
	DATE: MARCH 2008	SCALE: N.T.S.	DRAWN BY: K.C.R.



**ETTL
ENGINEERS &
CONSULTANTS**

MAIN OFFICE
1717 East Erwin
Tyler, Texas 75702
(903) 595-4421

MATERIAL DESCRIPTION

ASH SEDIMENT black;

--dark gray; with silty clay

--black; with sand

--gray

--black; with silt

Bottom of Boring @ 30'

USC
GEOLOGIC UNIT
WATER LEVEL

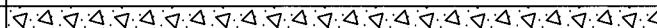

SAMPLES
DEPTH (ft)

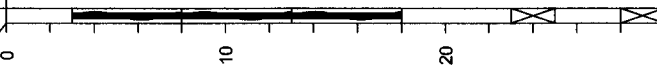

Water Level
Water Observations:

Est: Measured: Perched:
Seepage @ 5' while drilling.

Key to Abbreviations:
N - SPT Data (Blows/Ft)
P - Pocket Penetrometer (tsf)
T - Torvane (tsf)
L - Lab Vane Shear (tsf)

Notes:

GPS Coordinates: N 32° 15.549', W 94° 34.971'

LOG OF BORING B-14

PROJECT: Luminant Martin Lake PDP 1-3 Supplemental
Tatum, Texas

PROJECT NO.: G3219-09 BORING TYPE: Rotary Wash

FIELD STRENGTH DATA
● BLOW COUNT
▲ Qu (tsf)
■ PPR (tsf)
◆ Torvane (tsf)

DRY DENSITY (pcf)
COMPRESSIVE STRENGTH (tsf)
FAILURE STRAIN (%)
CONFINING PRESSURE (psi)

Natural Moisture Content and Atterberg Limits
Plastic Limit
Moisture Content
Liquid Limit

MOISTURE CONTENT (%)
LIQUID LIMIT
PLASTIC LIMIT
PLASTICITY INDEX
MINUS #200 SIEVE (%)
OTHER TESTS PERFORMED (Page Ref. #)

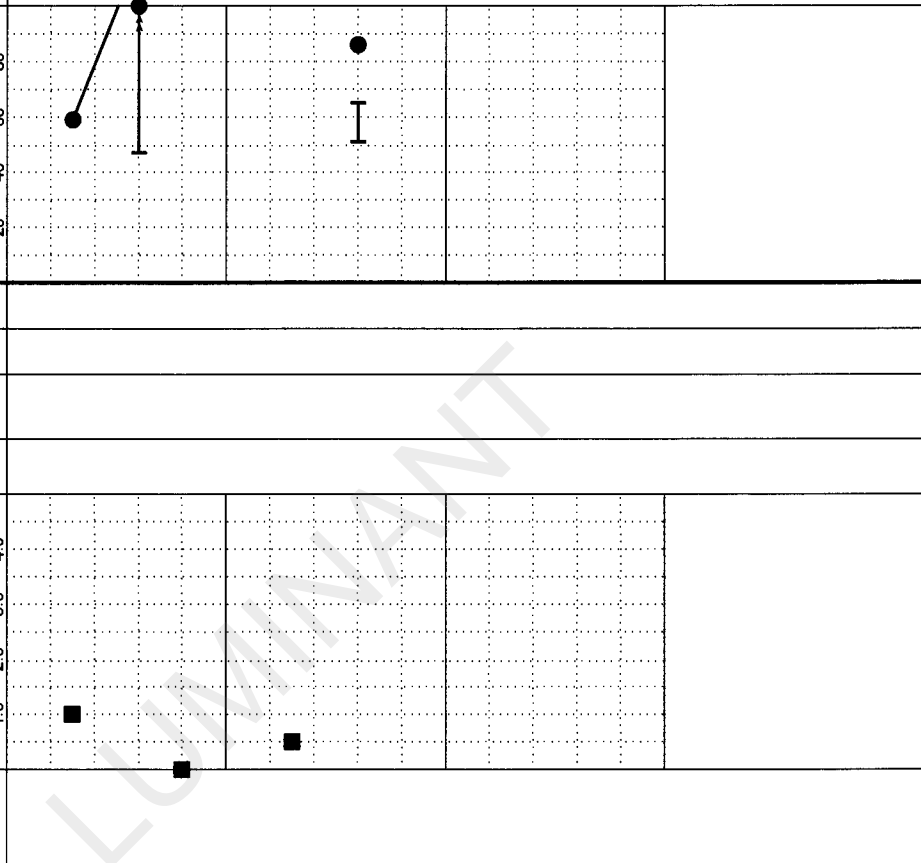

DATE 8/18/09

SURFACE ELEVATION



**ETTL
ENGINEERS &
CONSULTANTS**

MAIN OFFICE
1717 East Erwin
Tyler, Texas 75702
(903) 595-4421

MATERIAL DESCRIPTION

LEAN CLAY (CL) tan, gray, and red
ASH SEDIMENT gray
--no recovery
--black; with clay and silt
ASH SEDIMENT gray; with sand; laminated
--with silt
--with sand
--full recovery
--no recovery
--black
--black and gray
Bottom of Boring @ 30'

USC
WATER LEVEL
GEOLOGIC UNIT

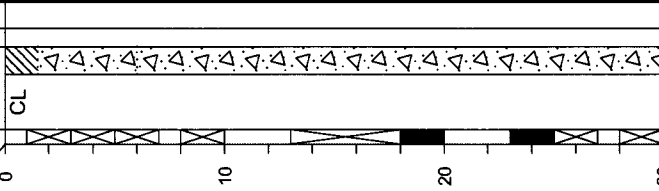

LOG OF BORING B-15
PROJECT: Luminant Martin Lake PDP 1-3 Supplemental
Tatum, Texas
PROJECT NO.: G3219-09
BORING TYPE: Rotary Wash

FIELD STRENGTH DATA	BLOW COUNT	DRY DENSITY (pcf)	COMPRESSION STRENGTH (tsf)	FAILURE STRAIN (%)	CONFINING PRESSURE (psi)	Natural Moisture Content and Atterberg Limits			MOISTURE CONTENT (%)	ATTERBERG LIMITS (%)	MINUS #200 SIEVE (%)	OTHER TESTS PERFORMED (Page Ref. #)
						Qu (tsf)	PPR (tsf)	Torvane (tsf)				
N=16	1	1.0	1.0			20	40	60	80	42	47	+40 Sieve=9%, +4 Sieve=1%
N=10	2	2.0	2.0							79	95	+40 Sieve=2%, +4 Sieve=0%
N=22	3	3.0	3.0							54	85	+40 Sieve=7%, +4 Sieve=3%
N=2	4	4.0	4.0									
N=1												
N=9												
N=1												

DATE: 8/18/09
SURFACE ELEVATION:
Notes:
GPS Coordinates: N 32° 15.556', W 94° 34.913'
Key to Abbreviations:
N - SPT Data (Blows/Ft)
P - Pocket Penetrometer (tsf)
T - Torvane (tsf)
L - Lab Vane Shear (tsf)
Est. Measured Perched:
Seepage @ 5' while drilling.
Water Observations:



**ETTL
ENGINEERS &
CONSULTANTS**

MAIN OFFICE
1717 East Erwin
Tyler, Texas 75702
(903) 595-4421

DEPTH (ft)
0
10
20
30
40

SAMPLES

USC
CL
SC
ML
CL
SC
SP

GEOLOGIC UNIT
WATER LEVEL

MATERIAL DESCRIPTION

SANDY LEAN CLAY (CL) orange and tan

--tan and gray

--orange and tan

CLAYEY SAND (SC) gray and orange

SANDY CLAYEY SILT (ML) orange and light gray

LEAN CLAY (CL) gray and reddish tan

--orange and tan; with trace of lignite

CLAYEY SAND (SC) tan and brown

SAND (SP) gray

Bottom of Boring @ 40'

Water Level
Water Observations:

Est.: Measured: Perched:

Key to Abbreviations:
N - SPT Data (Blows/Ft)
P - Pocket Penetrometer (tsf)
T - Torvane (tsf)
L - Lab Vane Shear (tsf)

Notes:

GPS Coordinates: N 32° 15.484', W 94° 34.965'

LOG OF BORING B-16

PROJECT: Luminant Martin Lake PDP 1-3 Supplemental
Tatum, Texas

PROJECT NO.: G3219-09 BORING TYPE: Rotary Wash

DATE: 8/18/09

SURFACE ELEVATION

MOISTURE CONTENT (%)	ATTERBERG LIMITS (%)			OTHER TESTS PERFORMED (Page Ref. #)
	LIQUID LIMIT (LL)	PLASTIC LIMIT (PL)	PLASTICITY INDEX (PI)	
13	29	14	15	+40 Sieve=1%, +4 Sieve=0%
16	32	16	16	+40 Sieve=0%, +4 Sieve=0%
26	46	23	23	+40 Sieve=4%, +4 Sieve=1%
29	48	22	26	+40 Sieve=5%, +4 Sieve=0%
				MINUS #200 SIEVE (%)

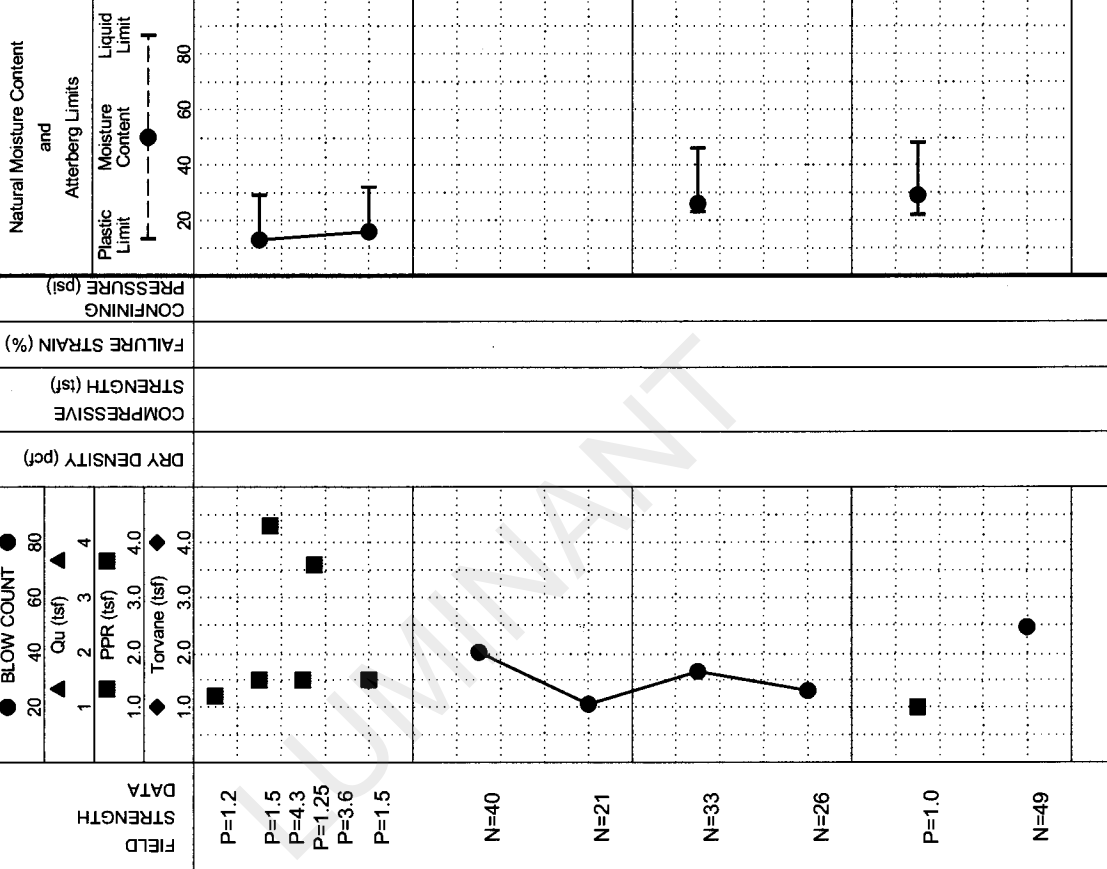

PLASTIC LIMIT
LIQUID LIMIT

COMPRESSION STRENGTH (tsf)

FAILURE STRAIN (%)

CONFINING PRESSURE (psf)

Natural Moisture Content and Atterberg Limits

MOISTURE CONTENT (%)

ATTERBERG LIMITS (%)

OTHER TESTS PERFORMED (Page Ref. #)



**ETTL
ENGINEERS &
CONSULTANTS**

MAIN OFFICE
1717 East Erwin
Tyler, Texas 75702
(903) 595-4421

MATERIAL DESCRIPTION

SANDY LEAN CLAY(CL) orange and tan
--orange and brown
--red, tan, and yellow
--tan and gray
CLAYEY SAND(SC) tan
--tan and brown
--tan and gray, laminated
--gray and orange
--tan
--tan and orange
Bottom of Boring @ 40'

DEPTH (#)
0
10
20
30
40

SAMPLES

USC

GEOLOGIC UNIT

WATER LEVEL

Water Level
Water Observations:
Est.: Measured: Perched:
Bailed to 20' and open upon completion.

LOG OF BORING B-17

PROJECT: Luminant Martin Lake PDP 1-3 Supplemental
Tatum, Texas

PROJECT NO.: G3219-09 BORING TYPE: Rotary Wash

FIELD DATA
STRENGTH
P=4.5+
P=4.0
P=4.5
P=4.5+
N=40
N=22
N=19
N=20
N=30
N=24

BLOW COUNT
● 20 40 60 80
▲ Qu (tsf) ▲ 4
■ PPR (tsf) ■ 4.0
◆ Torvane (tsf) ◆ 4.0

DRY DENSITY (pcf)
COMPRESSION STRENGTH (tsf)
FAILURE STRAIN (%)
CONFINING PRESSURE (psi)

Natural Moisture Content and Atterberg Limits
Plastic Limit
Moisture Content
Liquid Limit

MOISTURE CONTENT (%)
LIQUID LIMIT
PLASTIC LIMIT
PLASTICITY INDEX

ATTEBERG LIMITS(%)
LIQUID LIMIT
PLASTIC LIMIT
PLASTICITY INDEX

MINUS #200 SIEVE (%)
OTHER TESTS PERFORMED (Page Ref. #)

DATE
8/18/09
SURFACE ELEVATION

Notes:
GPS Coordinates: N 32° 15.566', W 94° 34.736'

Key to Abbreviations:
N - SPT Data (Blows/Ft)
P - Pocket Penetrometer (tsf)
T - Torvane (tsf)
L - Lab Vane Shear (tsf)

APPENDIX B
LABORATORY TEST RESULTS

LUMINANT

BOTTOM ASH PONDS AND SCRUBBER POND

LUMIVANT



500 Century Plaza Drive, Suite 190
 Houston, Texas 77073
 Telephone: (281) 821-6868
 Fax: (281) 821-6870

SUMMARY OF LABORATORY RESULTS

CLIENT Luminant

PROJECT NAME Pond Slope Stability

PROJECT NUMBER 123-94128

PROJECT LOCATION Martin Lake

Borehole	Depth	Liquid Limit	Plastic Limit	Plasticity Index	Maximum Size (mm)	% <#200 Sieve	Classification	Water Content (%)	Dry Density (pcf)	Saturation (%)	Void Ratio
BH-201	0.0							19.2			
BH-201	2.0							13.7			
BH-201	6.0	26	14	12				9.4			
BH-201	8.0							15.1			
BH-201	13.0							16.3			
BH-201	18.0							20.8			
BH-201	23.0	36	14	22				19.9			
BH-201	28.0							18.2			
BH-201	33.0							15.0			
BH-201	38.0				0.85	40		14.9			
BH-201	43.0							21.4			
BH-201	48.0							23.5			
BH-202	0.0							20.8			
BH-202	2.0	55	19	36				17.1			
BH-202	4.0							20.5			
BH-202	6.0							26.7			
BH-202	8.0							15.3			
BH-202	13.0							14.9			
BH-202	18.0	29	13	16				17.1			
BH-202	23.0							17.6			
BH-202	28.0				0.85	49		18.1			
BH-202	33.0							17.0			
BH-202	38.0							20.8			
BH-202	43.0							23.0			
BH-202	48.0							26.2			
BH-203	0.0							12.6			
BH-203	2.0							14.6			
BH-203	4.0							16.1			
BH-203	6.0	50	19	31				21.5			
BH-203	8.0							22.3			
BH-203	13.0							18.0			
BH-203	18.0							14.6			
BH-203	23.0							17.3			
BH-203	25.0							19.9			
BH-203	28.0				2	17		23.6			
BH-203	30.0							27.7			
BH-203	33.0							29.1			
BH-203	38.0							29.4			
BH-204	0.0							13.9			
BH-204	2.0							21.1			
BH-204	4.0							15.0			
BH-204	6.0							16.6			
BH-204	8.0							13.5			

LAB SUMMARY - GINT STD US LAB.GDT - 11/29/12 16:20 - P1 - 2012 PROJECT FOLDERS\123-94128 LUMINANT POND SLOPE STABILITY\MARTIN LAKE\94128\MARTINLAKE.GPJ



500 Century Plaza Drive, Suite 190
 Houston, Texas 77073
 Telephone: (281) 821-6868
 Fax: (281) 821-6870

SUMMARY OF LABORATORY RESULTS

CLIENT Luminant

PROJECT NAME Pond Slope Stability

PROJECT NUMBER 123-94128

PROJECT LOCATION Martin Lake

Borehole	Depth	Liquid Limit	Plastic Limit	Plasticity Index	Maximum Size (mm)	% <#200 Sieve	Classification	Water Content (%)	Dry Density (pcf)	Saturation (%)	Void Ratio
BH-204	28.0				4.75	58		19.1			
BH-204	33.0							13.8			
BH-204	38.0							21.0			
BH-204	43.0	51	20	31				26.6			
BH-204	48.0							23.8			
BH-205	0.0							17.5			
BH-205	2.0							15.6			
BH-205	4.0							15.5			
BH-205	6.0							20.7			
BH-205	8.0							17.4			
BH-205	13.0	47	15	32				23.0			
BH-205	18.0							22.9			
BH-205	23.0	28	17	11				16.3			
BH-205	28.0				4.75	69		16.4			
BH-205	33.0							14.7			
BH-205	38.0							25.4			
BH-205	43.0							26.7			
BH-205	48.0							25.0			
BH-205	53.0				9.5	11		25.9			
BH-206	0.0							17.1			
BH-206	2.0	44	15	29				15.6			
BH-206	4.0							14.0			
BH-206	6.0							16.2			
BH-206	8.0							21.7			
BH-206	13.0							18.1			
BH-206	18.0							12.2			
BH-206	23.0							15.9			
BH-206	28.0	59	17	42				20.3			
BH-206	33.0							19.8			
BH-206	38.0							18.2			
BH-206	43.0							22.1			
BH-206	48.0							23.3			
BH-206	53.0							23.0			
BH-206	58.0							22.1			
BH-207	0.0							15.6			
BH-207	2.0							15.3			
BH-207	4.0							14.9			
BH-207	6.0							18.2			
BH-207	13.0							18.9			
BH-207	18.0							13.0			
BH-207	23.0							16.9			
BH-207	28.0	31	16	15				16.7			
BH-207	33.0							17.4			

LAB SUMMARY - GINT STD US LAB.GDT - 11/29/12 16:20 - P1 - 2012 PROJECT FOLDERS\123-94128 LUMINANT POND SLOPE STABILITY\MARTIN LAKE\94128\MARTINLAKE.GPJ



500 Century Plaza Drive, Suite 190
Houston, Texas 77073
Telephone: (281) 821-6868
Fax: (281) 821-6870

SUMMARY OF LABORATORY RESULTS

CLIENT Luminant

PROJECT NAME Pond Slope Stability

PROJECT NUMBER 123-94128

PROJECT LOCATION Martin Lake

Borehole	Depth	Liquid Limit	Plastic Limit	Plasticity Index	Maximum Size (mm)	% <#200 Sieve	Classification	Water Content (%)	Dry Density (pcf)	Saturation (%)	Void Ratio
BH-207	38.0							19.0			
BH-207	43.0							21.8			
BH-207	48.0							22.2			
BH-207	53.0							25.2			
BH-207	58.0							29.8			
BH-208	0.0							20.2			
BH-208	2.0							16.2			
BH-208	4.0							12.9			
BH-208	6.0							11.5			
BH-208	8.0	28	15	13				15.2			
BH-208	13.0							15.9			
BH-208	18.0							20.2			
BH-208	23.0							18.0			
BH-208	28.0							21.3			
BH-208	33.0							18.1			
BH-208	38.0							19.1			
BH-208	43.0							23.7			
BH-208	48.0				4.75	11		24.5			
BH-208	53.0							27.1			
BH-208	58.0							26.1			
BH-209	0.0							9.0			
BH-209	2.0							11.8			
BH-209	4.0	62	21	41				11.8			
BH-209	6.0							12.1			
BH-209	8.0							19.2			
BH-209	13.0							12.3			
BH-209	18.0							21.0			
BH-209	28.0	41	15	26				23.3			
BH-209	33.0							20.0			
BH-209	35.0							21.2			
BH-209	38.0							17.9			
BH-209	43.0							24.0			
BH-209	48.0							21.2			
BH-210	0.0							8.2			
BH-210	2.0							10.7			
BH-210	4.0							13.4			
BH-210	6.0							14.4			
BH-210	8.0							15.7			
BH-210	13.0							21.3			
BH-210	18.0	36	14	22				22.9			
BH-210	23.0							25.0			
BH-210	28.0							18.5			
BH-210	33.0							19.3			

LAB SUMMARY - GINT STD US LAB.GDT - 11/29/12 16:20 - P1 - 2012 PROJECT FOLDERS\123-94128 LUMINANT POND SLOPE STABILITY\MARTIN LAKE\94128\MARTINLAKE.GPJ



500 Century Plaza Drive, Suite 190
 Houston, Texas 77073
 Telephone: (281) 821-6868
 Fax: (281) 821-6870

SUMMARY OF LABORATORY RESULTS

CLIENT Luminant

PROJECT NAME Pond Slope Stability

PROJECT NUMBER 123-94128

PROJECT LOCATION Martin Lake

Borehole	Depth	Liquid Limit	Plastic Limit	Plasticity Index	Maximum Size (mm)	%<#200 Sieve	Classification	Water Content (%)	Dry Density (pcf)	Saturation (%)	Void Ratio
BH-210	38.0							17.2			
BH-210	43.0							25.6			
BH-210	48.0				9.5	33		33.4			
BH-210	53.0							29.3			
BH-210	58.0							29.3			
BH-210	63.0							26.6			
BH-210	68.0							31.1			
BH-211	0.0							8.7			
BH-211	2.0							13.3			
BH-211	4.0							15.0			
BH-211	6.0							14.5			
BH-211	8.0							13.2			
BH-211	13.0							17.6			
BH-211	18.0	50	17	33				15.0			
BH-211	23.0							11.6			
BH-211	28.0				9.5	52		11.6			
BH-211	33.0							22.5			
BH-211	38.0							21.1			
BH-211	43.0							24.3			
BH-211	48.0							24.3			
BH-211	53.0							24.9			
BH-211	58.0							22.9			
BH-211	63.0							29.5			
BH-211	68.0							26.6			

LAB SUMMARY - GINT STD US LAB.GDT - 11/29/12 16:20 - P1_2012 PROJECT FOLDERS\123-94128 LUMINANT POND SLOPE STABILITY\MARTIN LAKE\94128\MARTINLAKE.GPJ



500 Century Plaza Drive, Suite 190
Houston, Texas 77073
Telephone: (281) 821-6868
Fax: (281) 821-6870

ATTERBERG LIMITS' RESULTS

CLIENT Luminant

PROJECT NAME Pond Slope Stability

PROJECT NUMBER 123-94128

PROJECT LOCATION Martin Lake

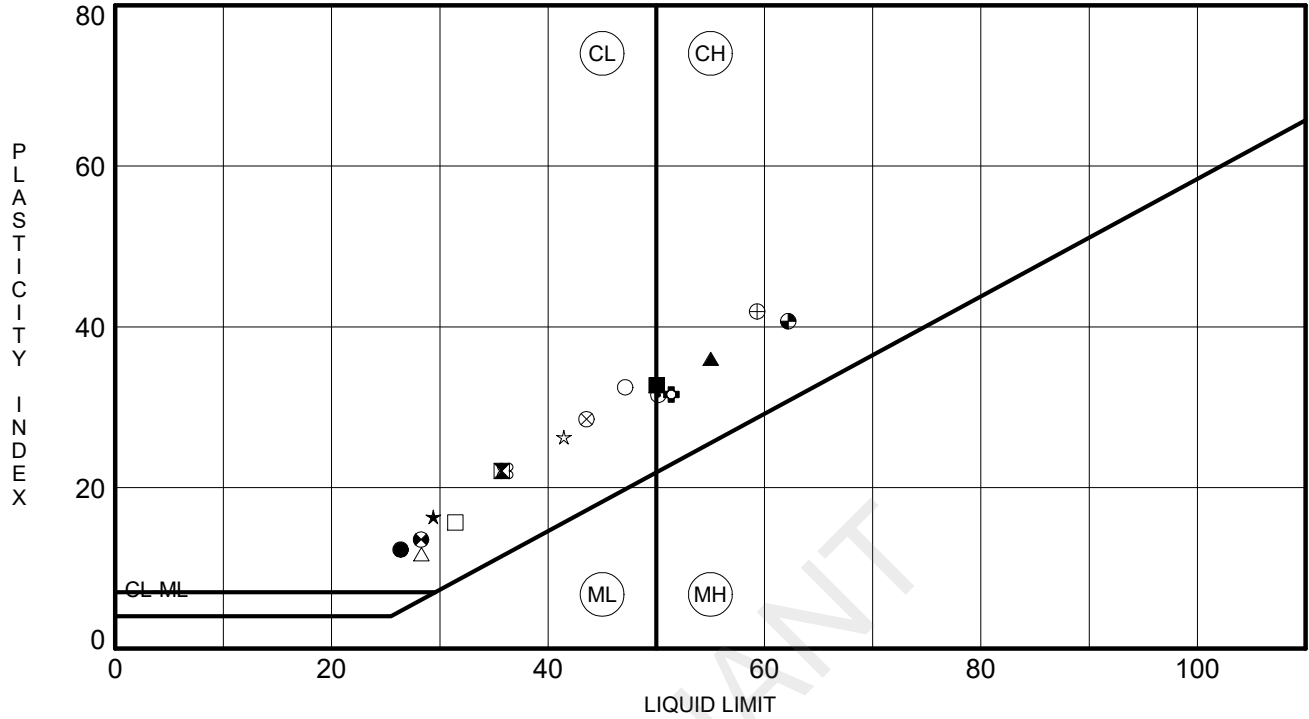

ATTERBERG LIMITS - GINT STD US LAB.GDT - 11/29/12 16:21 - P:_2012 PROJECT FOLDERS\123-94128 LUMINANT POND SLOPE STABILITY\MARTIN LAKE\94128\MARTINLAKE.GPJ

	BOREHOLE	DEPTH	LL	PL	PI	Fines	Classification
●	BH-201	6.0	26	14	12		
⊠	BH-201	23.0	36	14	22		
▲	BH-202	2.0	55	19	36		
★	BH-202	18.0	29	13	16		
⊕	BH-203	6.0	50	19	31		
⊕	BH-204	43.0	51	20	31		
○	BH-205	13.0	47	15	32		
△	BH-205	23.0	28	17	11		
⊗	BH-206	2.0	44	15	29		
⊕	BH-206	28.0	59	17	42		
□	BH-207	28.0	31	16	15		
⊕	BH-208	8.0	28	15	13		
⊕	BH-209	4.0	62	21	41		
★	BH-209	28.0	41	15	26		
⊗	BH-210	18.0	36	14	22		
■	BH-211	18.0	50	17	33		



500 Century Plaza Drive, Suite 190
Houston, Texas 77073
Telephone: (281) 821-6868
Fax: (281) 821-6870

GRAIN SIZE DISTRIBUTION

CLIENT Luminant

PROJECT NAME Pond Slope Stability

PROJECT NUMBER 123-94128

PROJECT LOCATION Martin Lake

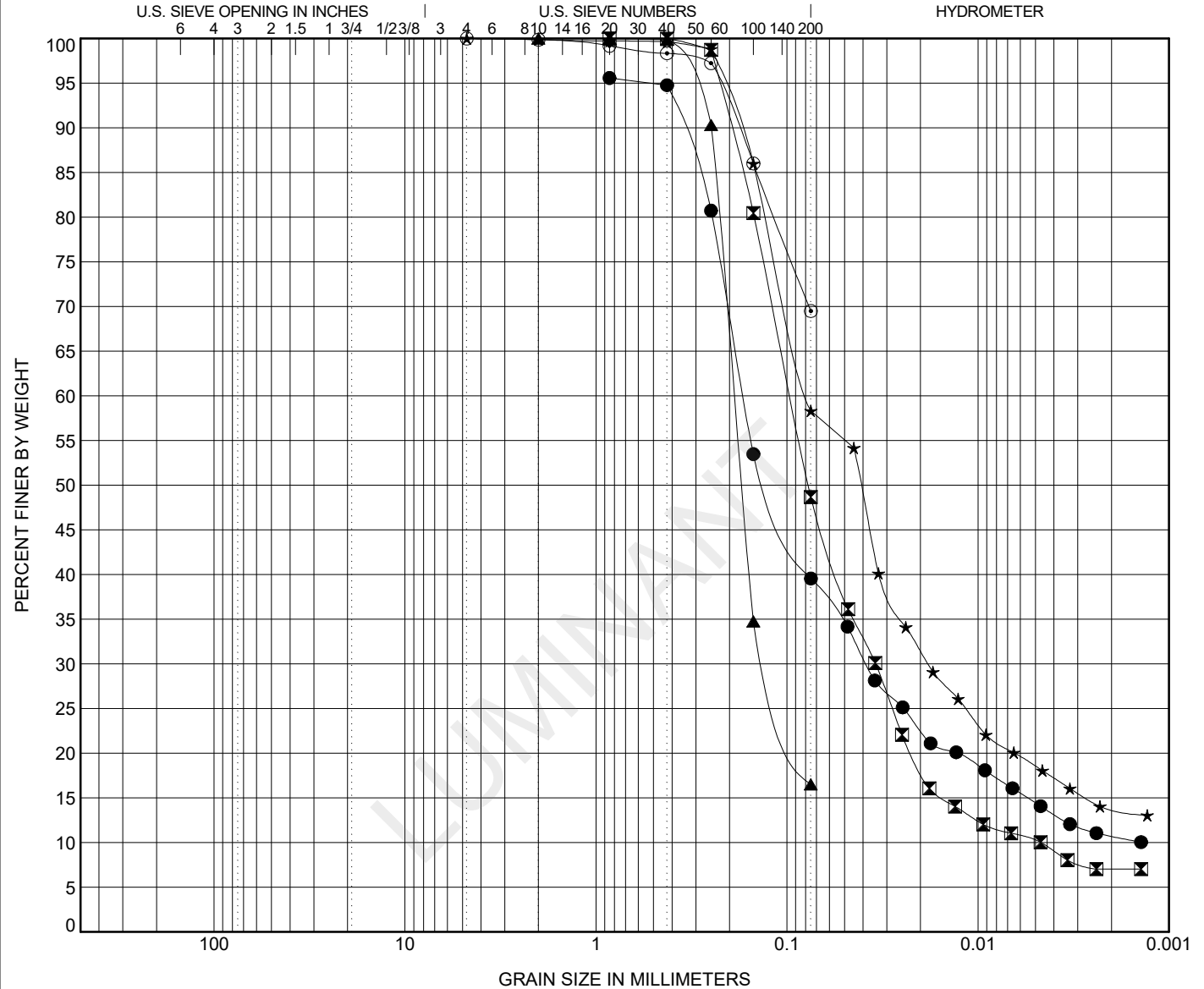

COBBLES	GRAVEL		SAND			SILT OR CLAY
	coarse	fine	coarse	medium	fine	

BOREHOLE	DEPTH	Classification					LL	PL	PI	Cc	Cu
● BH-201	38										
☒ BH-202	28								2.63	20.54	
▲ BH-203	28										
★ BH-204	28										
⊙ BH-205	28										
BOREHOLE	DEPTH	D100	D60	D30	D10	%Gravel	%Sand	%Silt	%Clay		
● BH-201	38	0.85	0.169	0.038			56.0	25.1	14.4		
☒ BH-202	28	0.85	0.096	0.034	0.005	0.0	51.3	38.4	10.2		
▲ BH-203	28	2	0.189	0.125		0.0	83.5	16.5			
★ BH-204	28	4.75	0.078	0.018		0.0	41.7	39.8	18.5		
⊙ BH-205	28	4.75				0.0	30.5	69.5			

GRAIN SIZE - COA - GINT STD US LAB.GDT - 11/29/12 - 16:21 - P:\2012 PROJECT FOLDERS\123-94128 LUMINANT POND SLOPE STABILITY\MARTIN LAKE\94128\MARTINLAKE.GPJ



500 Century Plaza Drive, Suite 190
Houston, Texas 77073
Telephone: (281) 821-6868
Fax: (281) 821-6870

GRAIN SIZE DISTRIBUTION

CLIENT Luminant

PROJECT NAME Pond Slope Stability

PROJECT NUMBER 123-94128

PROJECT LOCATION Martin Lake

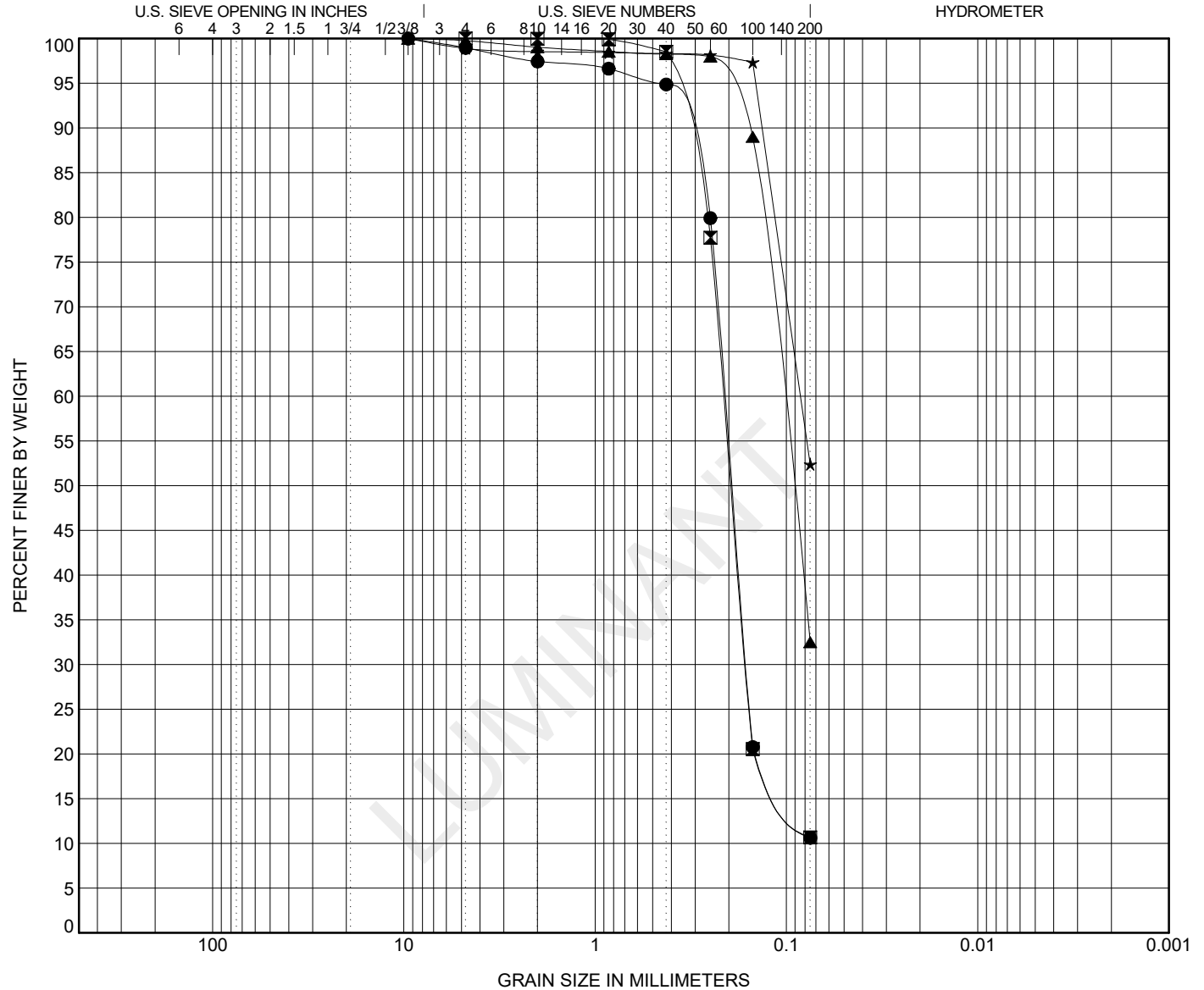

COBBLES	GRAVEL		SAND			SILT OR CLAY
	coarse	fine	coarse	medium	fine	

BOREHOLE	DEPTH	Classification					LL	PL	PI	Cc	Cu
● BH-205	53									1.74	2.93
☒ BH-208	48									1.75	2.98
▲ BH-210	48										
★ BH-211	28										

BOREHOLE	DEPTH	D100	D60	D30	D10	%Gravel	%Sand	%Silt	%Clay
● BH-205	53	9.5	0.21	0.162		1.1	88.3	10.6	
☒ BH-208	48	4.75	0.213	0.163		0.0	89.3	10.7	
▲ BH-210	48	9.5	0.105			0.2	67.2	32.5	
★ BH-211	28	9.5	0.084			1.1	46.5	52.4	

GRAIN SIZE - COA - GINT STD US LAB.GDT - 11/29/12 - 16:21 - P:\2012 PROJECT FOLDERS\123-94128 LUMINANT POND SLOPE STABILITY\MARTIN LAKE\94128\MARTINLAKE.GPJ

**UNCONSOLIDATED / UNDRAINED COMPRESSIVE STRENGTH
ASTM D 2850**

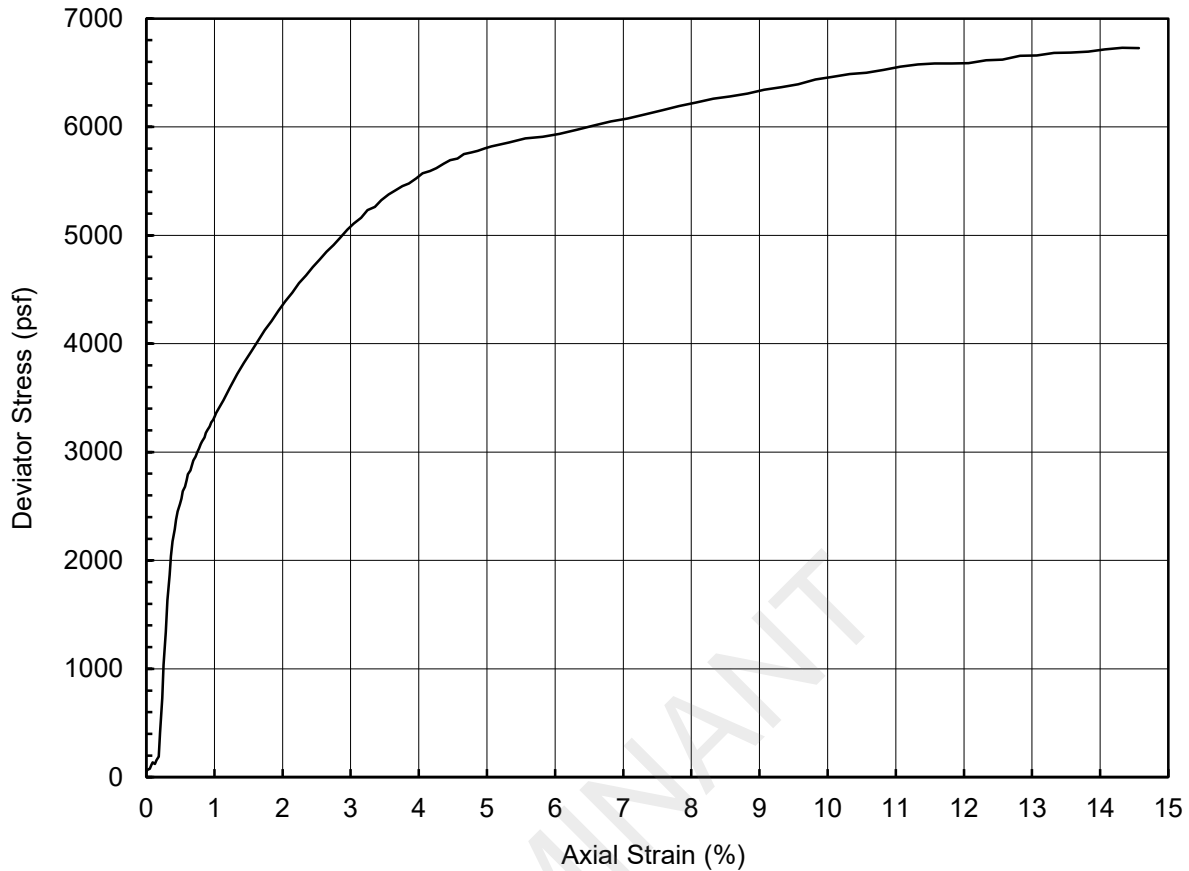

Specimen Description	Reddish Yellow Clay (visual classification)			
LL		PI	LI	USCS

Depth (ft)	4.0	Confining Pressure (psf)	617
Specimen Height (inch)	6.0	Strain Rate (%/min)	1.0
Specimen Diameter (inch)	2.8	Peak Deviator Stress (psf)	6732
Initial Specimen Weight (g)	1263.7	Axial Strain at Peak Stress (%)	14.3
Moist Unit Weight (pcf)	131.9		
Initial Water Content (%)	15		
Initial Dry Unit Weight (pcf)	114.6		

Project Title	Luminant - Martin Lake Slope Stability
Project Number	123-94128
Sample Type	Shelby Tube
Sample ID	BH-201 TO-3
Comments	

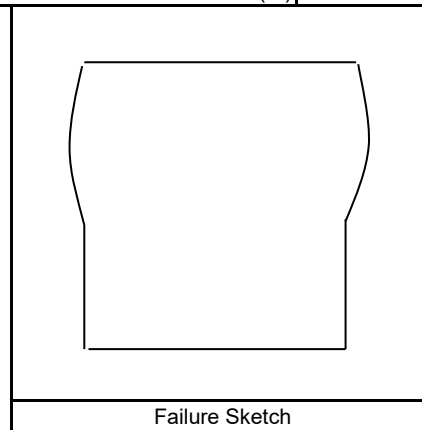

Performed by	PN
Date	12-Nov-12
Check	HR
Review	SBK

**UNCONSOLIDATED / UNDRAINED COMPRESSIVE STRENGTH
ASTM D 2850**

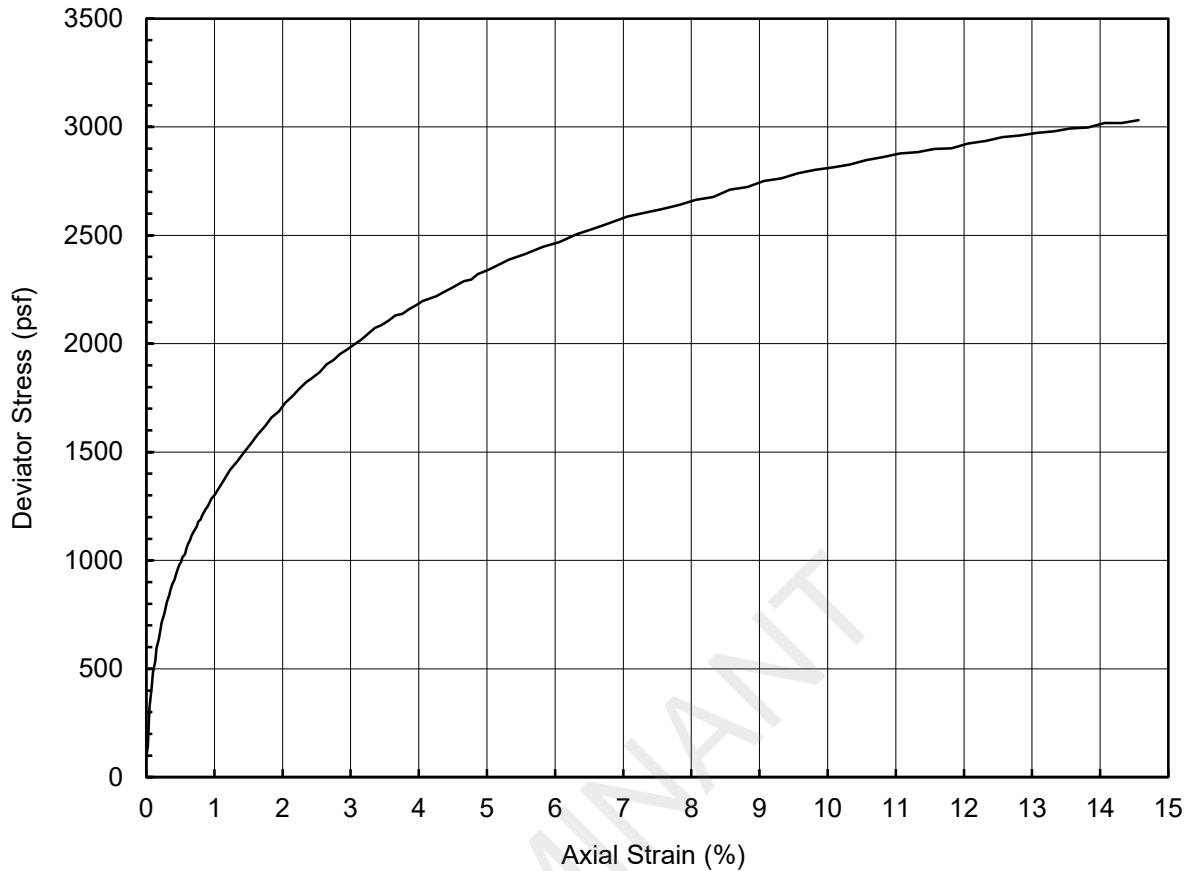

Specimen Description	Reddish Yellow Clay (visual classification)			
LL		PI	LI	USCS

Depth (ft)	18.0	Confining Pressure (psf)	2371
Specimen Height (inch)	5.9	Strain Rate (%/min)	1.0
Specimen Diameter (inch)	2.8	Peak Deviator Stress (psf)	3035
Initial Specimen Weight (g)	1232.8	Axial Strain at Peak Stress (%)	14.8
Moist Unit Weight (pcf)	132.4		
Initial Water Content (%)	19		
Initial Dry Unit Weight (pcf)	111.7		

Project Title	Luminant - Martin Lake Slope Stability
Project Number	123-94128
Sample Type	Shelby Tube
Sample ID	BH-202 TO-7
Comments	

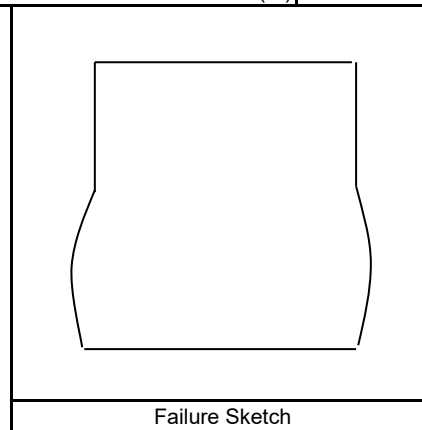

Performed by	PN
Date	13-Nov-12
Check	HR
Review	SBK

**UNCONSOLIDATED / UNDRAINED COMPRESSIVE STRENGTH
ASTM D 2850**

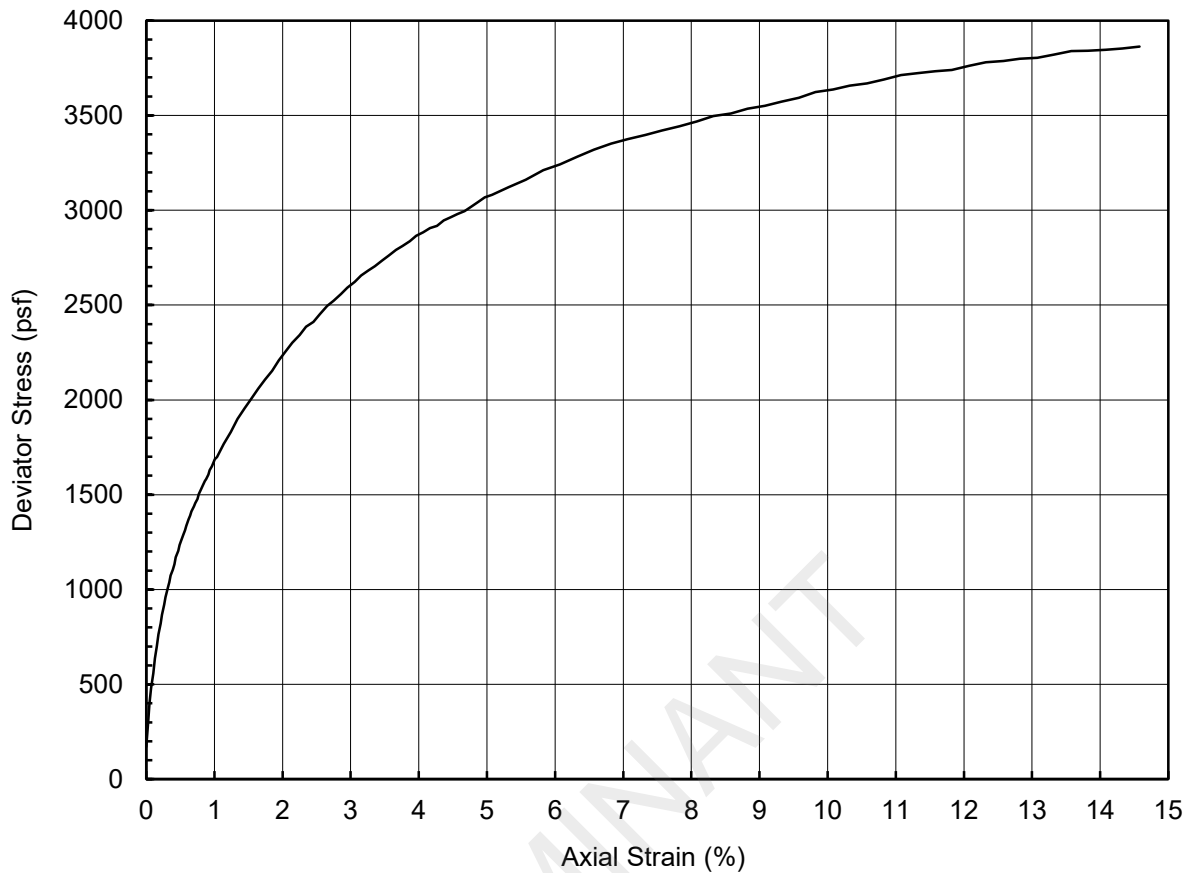

Specimen Description					Reddish Gray Clay (visual classification)				
LL		PI		LI		USCS			

Depth (ft)	6.0	Confining Pressure (psf)	858
Specimen Height (inch)	6.0	Strain Rate (%/min)	1.0
Specimen Diameter (inch)	2.8	Peak Deviator Stress (psf)	3877
Initial Specimen Weight (g)	1199.6	Axial Strain at Peak Stress (%)	14.8
Moist Unit Weight (pcf)	124.7		
Initial Water Content (%)	21		
Initial Dry Unit Weight (pcf)	102.7		

Project Title	Luminant - Martin Lake Slope Stability		
Project Number	123-94128		
Sample Type	Shelby Tube		
Sample ID	BH-203	TO-4	
Comments			

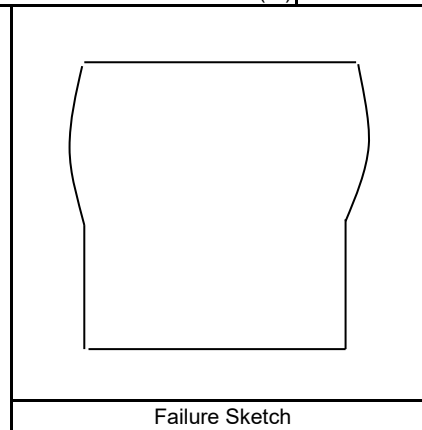

Performed by	PN
Date	13-Nov-12
Check	HR
Review	SBK

**UNCONSOLIDATED / UNDRAINED COMPRESSIVE STRENGTH
ASTM D 2850**

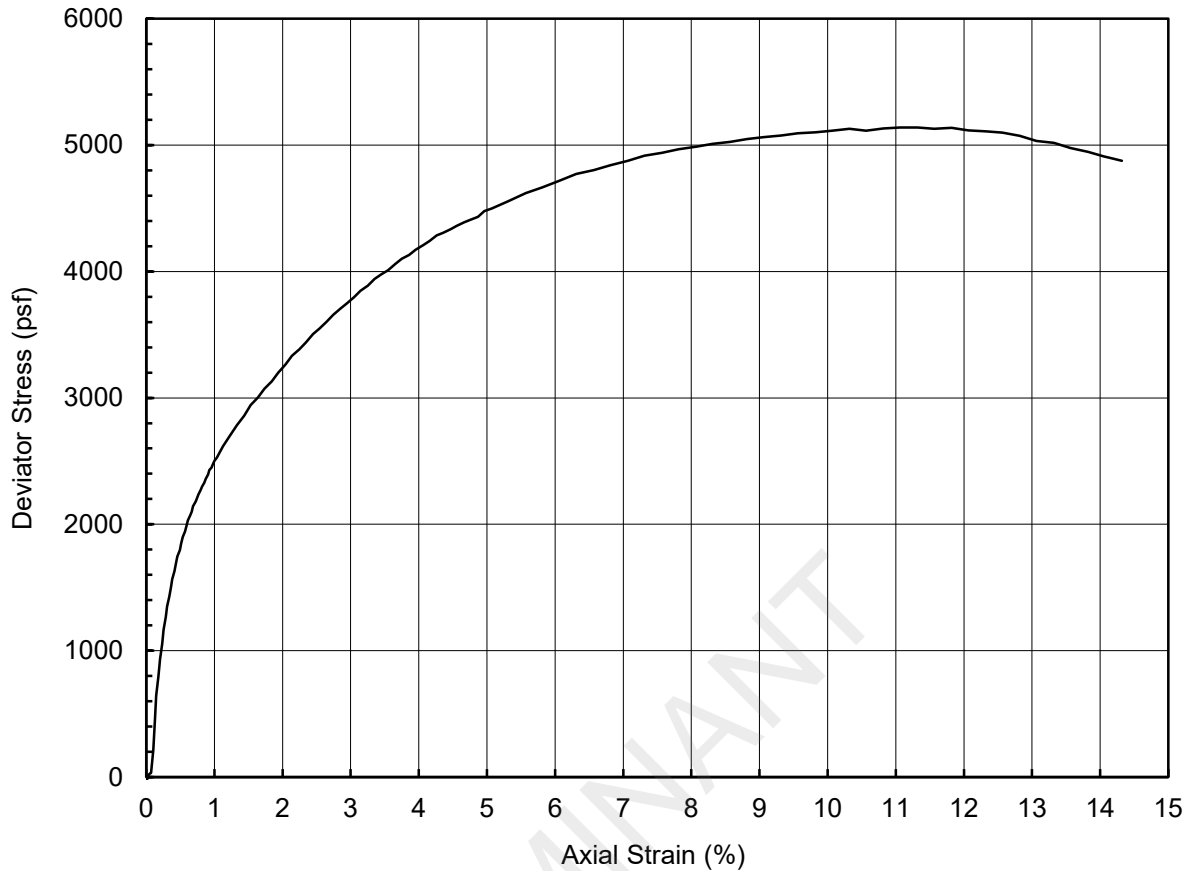

Specimen Description					Reddish Gray Clay (visual classification)				
LL		PI		LI		USCS			

Depth (ft)	23.0	Confining Pressure (psf)	3008
Specimen Height (inch)	6.0	Strain Rate (%/min)	1.0
Specimen Diameter (inch)	2.8	Peak Deviator Stress (psf)	5139
Initial Specimen Weight (g)	1192.8	Axial Strain at Peak Stress (%)	11.3
Moist Unit Weight (pcf)	126.6		
Initial Water Content (%)	26		
Initial Dry Unit Weight (pcf)	100.9		

Project Title	Luminant - Martin Lake Slope Stability		
Project Number	123-94128		
Sample Type	Shelby Tube		
Sample ID	BH-204	TO-8	
Comments			

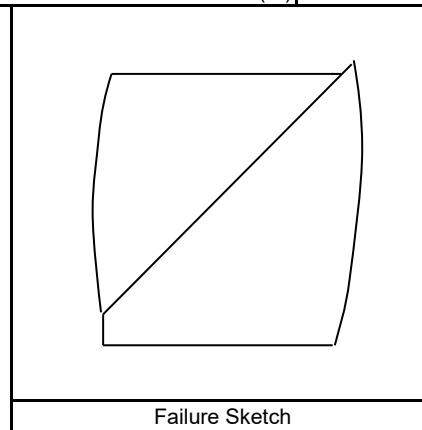

Performed by	PN
Date	13-Nov-12
Check	HR
Review	SBK

**UNCONSOLIDATED / UNDRAINED COMPRESSIVE STRENGTH
ASTM D 2850**

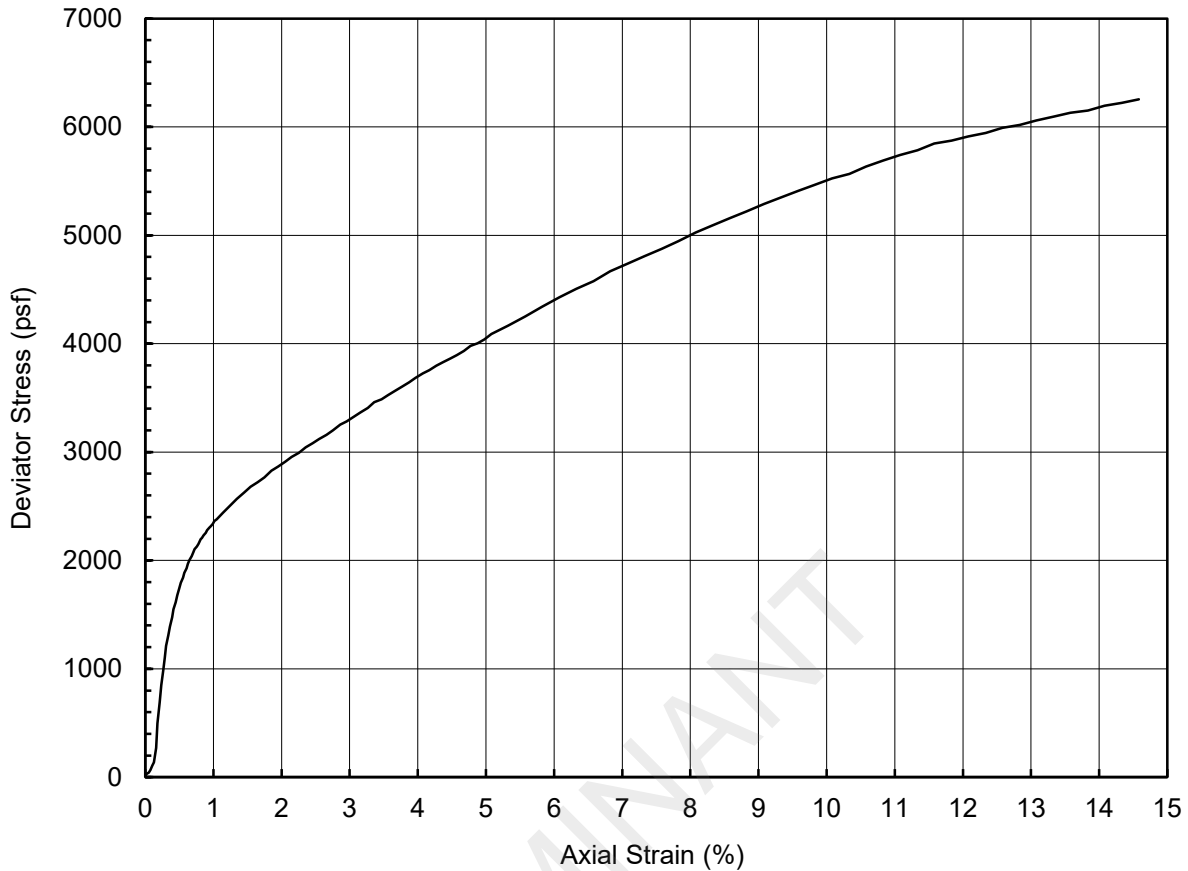

Specimen Description	Reddish Yellow Clay (visual classification)			
LL		PI	LI	USCS

Depth (ft)	13.0	Confining Pressure (psf)	1760
Specimen Height (inch)	5.9	Strain Rate (%/min)	1.0
Specimen Diameter (inch)	2.8	Peak Deviator Stress (psf)	6270
Initial Specimen Weight (g)	1252.5	Axial Strain at Peak Stress (%)	14.8
Moist Unit Weight (pcf)	131.9		
Initial Water Content (%)	27		
Initial Dry Unit Weight (pcf)	104.1		

Project Title	Luminant - Martin Lake Slope Stability
Project Number	123-94128
Sample Type	Shelby Tube
Sample ID	BH-205 TO-6
Comments	

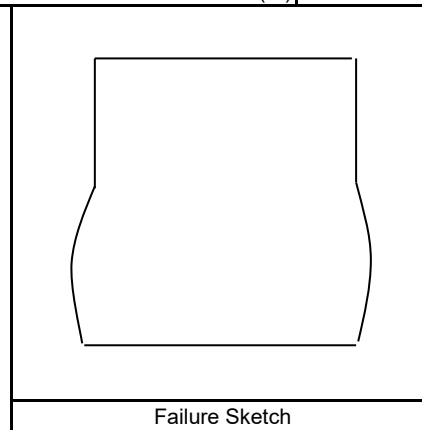

Performed by	PN
Date	13-Nov-12
Check	HR
Review	SBK

**UNCONSOLIDATED / UNDRAINED COMPRESSIVE STRENGTH
ASTM D 2850**

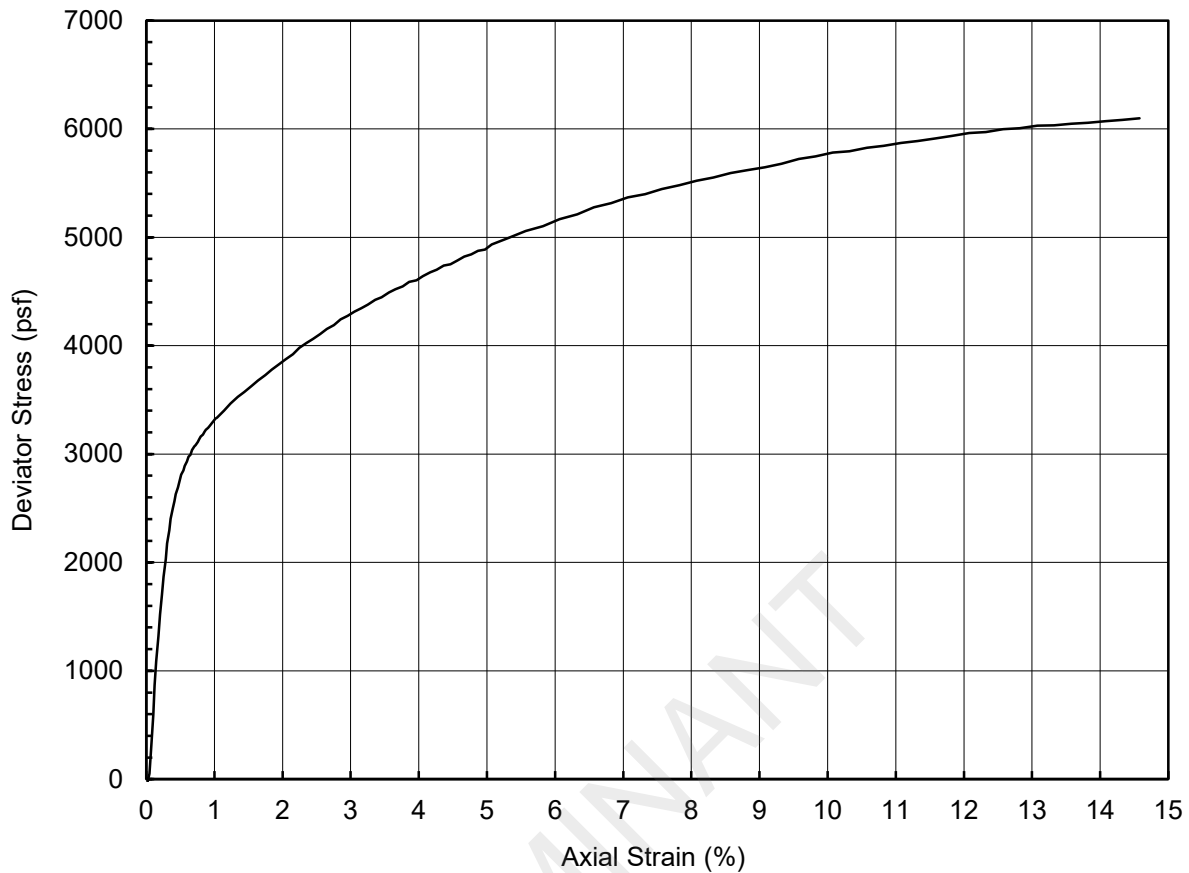

Specimen Description		Grayish Brown Fat Clay					
LL	59	PI	42	LI	0.1	USCS	CH

Depth (ft)	28.0	Confining Pressure (psf)	3627
Specimen Height (inch)	5.9	Strain Rate (%/min)	1.0
Specimen Diameter (inch)	2.8	Peak Deviator Stress (psf)	6110
Initial Specimen Weight (g)	1219.7	Axial Strain at Peak Stress (%)	14.8
Moist Unit Weight (pcf)	127.5		
Initial Water Content (%)	20		
Initial Dry Unit Weight (pcf)	106.6		

Project Title	Luminant - Martin Lake Slope Stability	
Project Number	123-94128	
Sample Type	Shelby Tube	
Sample ID	BH-206	TO-9
Comments		

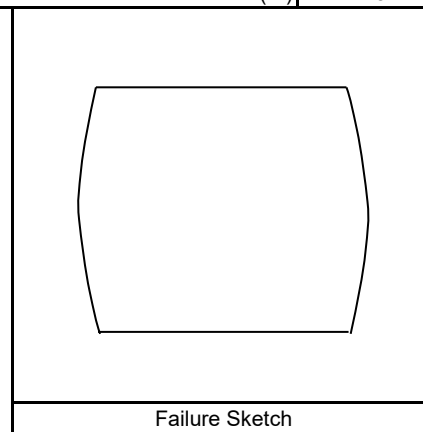

Performed by	PN
Date	15-Nov-12
Check	HR
Review	JF

**UNCONSOLIDATED / UNDRAINED COMPRESSIVE STRENGTH
ASTM D 2850**

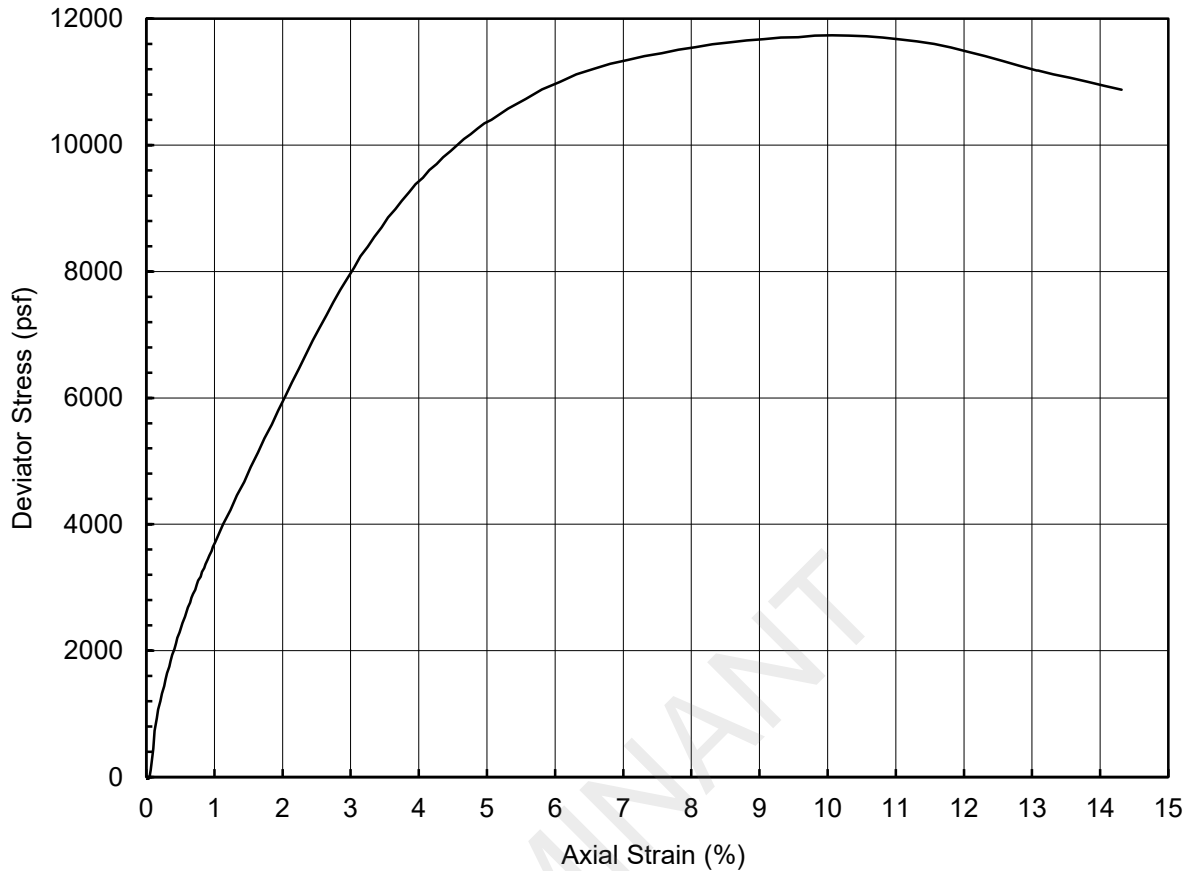

Specimen Description		Grayish Brown Lean Clay					
LL	31	PI	15	LI	0.0	USCS	CL

Depth (ft)	28.0	Confining Pressure (psf)	3620
Specimen Height (inch)	5.9	Strain Rate (%/min)	1.0
Specimen Diameter (inch)	2.8	Peak Deviator Stress (psf)	11735
Initial Specimen Weight (g)	1251.9	Axial Strain at Peak Stress (%)	10.1
Moist Unit Weight (pcf)	127.7		
Initial Water Content (%)	16		
Initial Dry Unit Weight (pcf)	109.9		

Project Title	Luminant - Martin Lake Slope Stability
Project Number	123-94128
Sample Type	Shelby Tube
Sample ID	BH-207 TO-9
Comments	

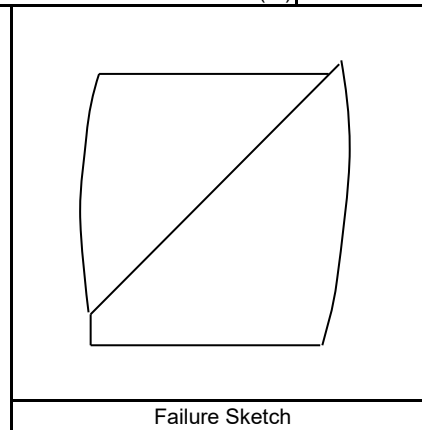

Performed by	PN
Date	15-Nov-12
Check	HR
Review	JF

**UNCONSOLIDATED / UNDRAINED COMPRESSIVE STRENGTH
ASTM D 2850**

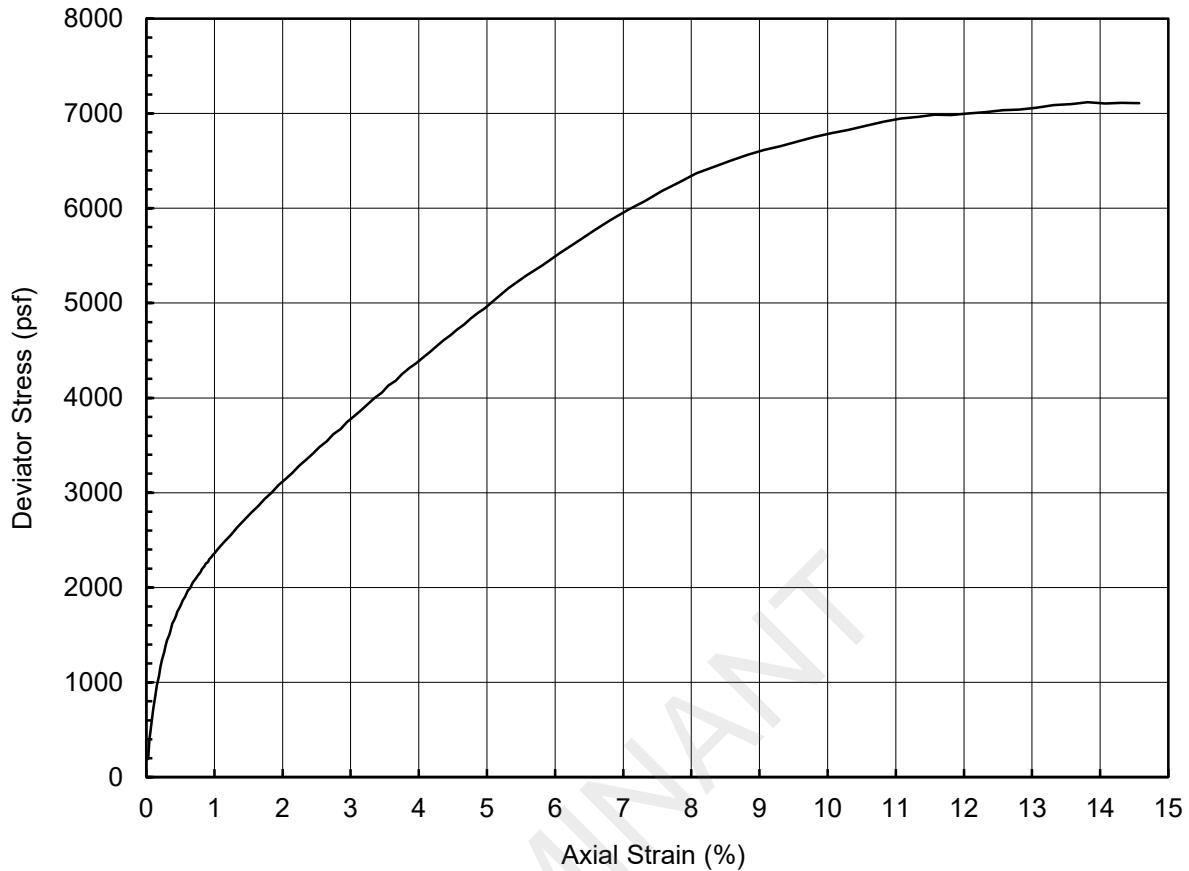

Specimen Description		Reddish Yellow Lean Clay					
LL	28	PI	13	LI	0.0	USCS	CL

Depth (ft)	8.0	Confining Pressure (psf)	1046
Specimen Height (inch)	5.9	Strain Rate (%/min)	1.0
Specimen Diameter (inch)	2.8	Peak Deviator Stress (psf)	7118
Initial Specimen Weight (g)	1287.7	Axial Strain at Peak Stress (%)	13.8
Moist Unit Weight (pcf)	138.1		
Initial Water Content (%)	14		
Initial Dry Unit Weight (pcf)	120.7		

Project Title	Luminant - Martin Lake Slope Stability
Project Number	123-94128
Sample Type	Shelby Tube
Sample ID	BH-208 TO-5
Comments	

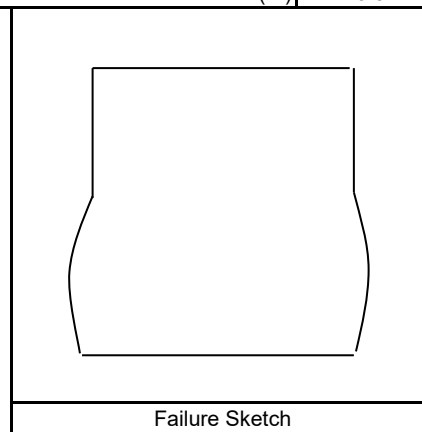

Performed by	PN
Date	16-Nov-12
Check	HR
Review	JF

**UNCONSOLIDATED / UNDRAINED COMPRESSIVE STRENGTH
ASTM D 2850**

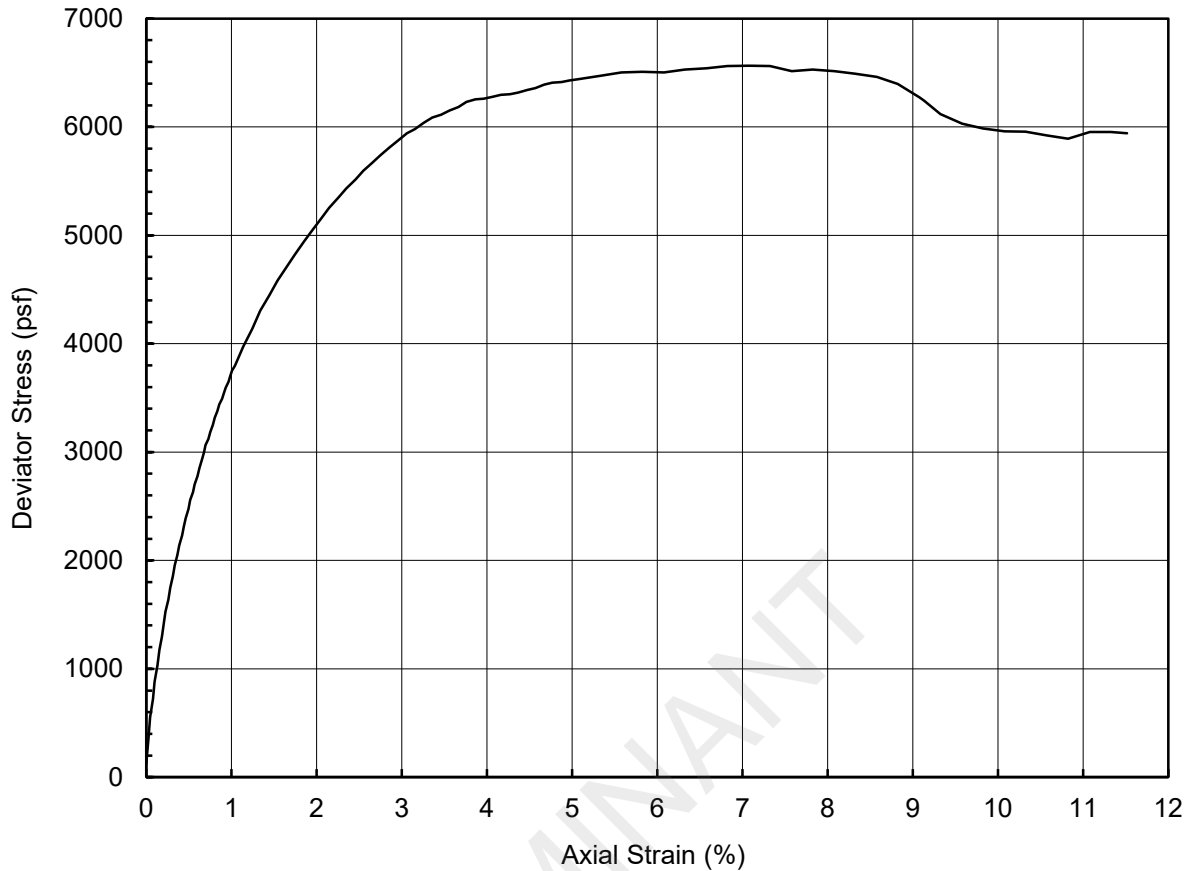

Specimen Description		Grayish Brown Lean Clay					
LL	41	PI	26	LI	0.3	USCS	CL

Depth (ft)	28.0	Confining Pressure (psf)	3624
Specimen Height (inch)	6.0	Strain Rate (%/min)	1.0
Specimen Diameter (inch)	2.8	Peak Deviator Stress (psf)	6566
Initial Specimen Weight (g)	1202.8	Axial Strain at Peak Stress (%)	7.1
Moist Unit Weight (pcf)	128.0		
Initial Water Content (%)	22		
Initial Dry Unit Weight (pcf)	104.7		

Project Title	Luminant - Martin Lake Slope Stability
Project Number	123-94128
Sample Type	Shelby Tube
Sample ID	BH-209 TO-9
Comments	

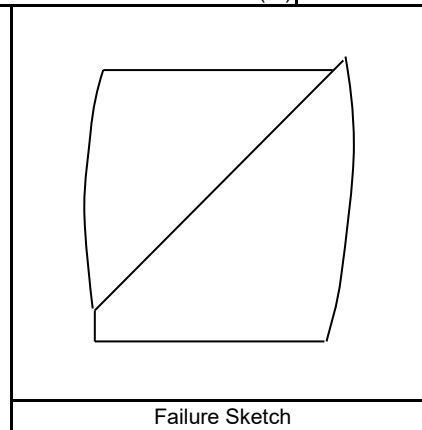

Performed by	PN
Date	16-Nov-12
Check	HR
Review	JF

**UNCONSOLIDATED / UNDRAINED COMPRESSIVE STRENGTH
ASTM D 2850**

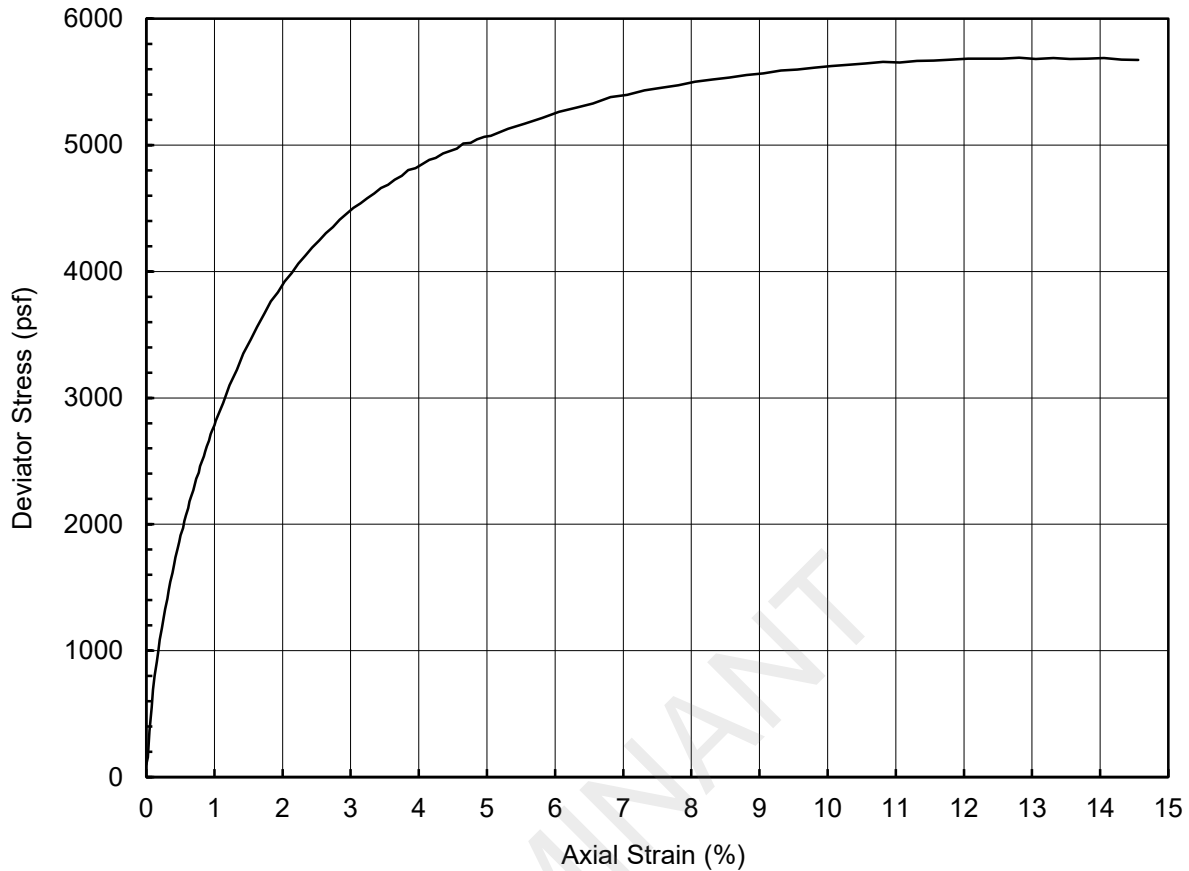

Specimen Description		Reddish Gray Lean Clay					
LL	36	PI	22	LI	0.5	USCS	CL

Depth (ft)	18.0	Confining Pressure (psf)	2375
Specimen Height (inch)	6.0	Strain Rate (%/min)	1.0
Specimen Diameter (inch)	2.8	Peak Deviator Stress (psf)	5691
Initial Specimen Weight (g)	1192.0	Axial Strain at Peak Stress (%)	12.8
Moist Unit Weight (pcf)	126.7		
Initial Water Content (%)	24		
Initial Dry Unit Weight (pcf)	102.2		

Project Title	Luminant - Martin Lake Slope Stability
Project Number	123-94128
Sample Type	Shelby Tube
Sample ID	BH-210 TO-7
Comments	

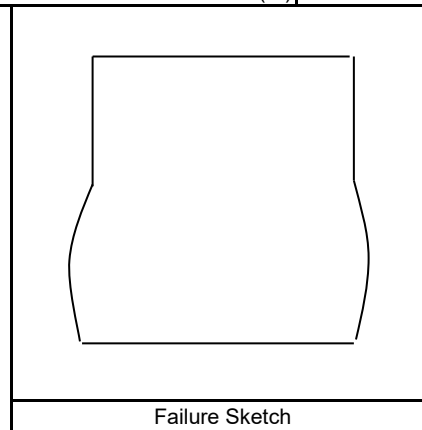

Performed by	PN
Date	16-Nov-12
Check	HR
Review	JF

PROJECT INFORMATION

PROJECT: Luminant East Area District
LOCATION: Rock County, Texas
PROJECT NO: D 2972 - 01
CLIENT:
November 2008

TRIAxIAL TEST PROGRAM BY GARRY H. GREGORY, P.E.

ALL RIGHTS RESERVED - UNAUTHORIZED USE PROHIBITED
VERSION 1.0 - AUGUST 1998 - REVISED MARCH 24, 1999

THIS COPY LICENSED TO:
ETTL ENGINEERS AND CONSULTANTS, INC.
1717 East Erwin
Tyler, TX 75702

TEST DESCRIPTION

TYPE OF TEST & NO.: CU-100 PP
SAMPLE TYPE: Possible Fr Sample
DESCRIPTION: Tan, Brown & Red Sandy Lean Clay
Sampled on Site: B-13 3' to 10' deep
ASSUMED SPECIFIC GRAVITY: 2.7 * 40 Sieve
LL: PL: PI: Percent -200:
REMARKS: Both Ends & Diameter Trimmed * # 4 Sieve

PLATE: B.1

PLATE: B.2

PLATE: B.3

Number of Specimens = 3

SPECIMEN DATA
SPECIMEN NO. 1

	initial	final	Diameter		Height	
Moist soil & Tare :	522.40 g	621.30 g	top	2.04 in	Ht 1	4.44 in
Dry soil and Tare :	458.75 g	544.40 g	mid	2.04 in	Ht 2	4.44 in
Tare :	129.85 g	119.40 g	bot	2.04 in	Ht 3	4.44 in
Moisture content :	13.35 %	13.00 %	Avg	2.04 in	Ht4	4.44 in
Weight:	466.1 g				Avg Ht	4.44 in
Change in Ht due to saturation :		-0.02 in	Initial specimen vol :		276.51 cc	
Change in Ht due to consolidation :		-0.018 in	At test specimen vol :		239.51 cc	
Change in pipet vol due to consolidation :		2.0 cc	Initial dry density :		1.2322 pcf	
Saturation Parameter " B " =	0.95		At test dry density:		1.2322 pcf	
Strain Rate (in/min) =	0.0005	Failure Strain % =	2.7	Effective Cell Pressure (psi) =	10.0	
σ_1' Failure (psi) =	20.41	σ_1 Failure (psi) =	23.09	Estimated v =	0.35	
σ_3' Failure (psi) =	5.41	σ_3 Failure (psi) =	10.0	Back Pressure (psi) =	50.0	
ΔU =	3.3	Total Pore Pressure =	54.6	Cell Pressure (psi) =	60.0	

SPECIMEN NO. 2

	initial	final	Diameter		Height	
Moist soil & Tare :	549.80 g	636.40 g	top	2.01 in	Ht 1	4.44 in
Dry soil and Tare :	489.20 g	560.20 g	mid	2.01 in	Ht 2	4.44 in
Tare :	121.20 g	139.15 g	bot	2.01 in	Ht 3	4.44 in
Moisture content :	10.95 %	13.0 %	Avg	2.01 in	Ht4	4.44 in
Weight:	406.0 g				Avg Ht	4.44 in
Change in Ht due to saturation :		-0.006 in	Initial specimen vol :		239.51 cc	
Change in Ht due to consolidation :		-0.034 in	At test specimen vol :		200.51 cc	
Change in pipet vol due to consolidation :		3.9 cc	Initial dry density :		1.2322 pcf	
Saturation Parameter " B " =	0.97		At test dry density:		1.2322 pcf	
Strain Rate (in/min) =	0.0005	Failure Strain % =	3.9	Effective Cell Pressure (psi) =	10.0	
σ_1' Failure (psi) =	37.62	σ_1 Failure (psi) =	40.50	Estimated v =	0.35	
σ_3' Failure (psi) =	12.02	σ_3 Failure (psi) =	20.0	Back Pressure (psi) =	50.0	
ΔU =	2.0	Total Pore Pressure =	58.0	Cell Pressure (psi) =	70.0	

SPECIMEN NO. 3

	initial	final	Diameter		Height	
Moist soil & Tare :	584.50 g	656.50 g	top	2.06 in	Ht 1	4.54 in
Dry soil and Tare :	510.10 g	579.20 g	mid	2.06 in	Ht 2	4.54 in
Tare :	126.30 g	139.30 g	bot	2.06 in	Ht 3	4.54 in
Moisture content :	15.35 %	17.57 %	Avg	2.06 in	Ht4	4.54 in
Weight:	519.0 g				Avg Ht	4.54 in
Change in Ht due to saturation :		-0.001 in	Initial specimen vol :		277.51 cc	
Change in Ht due to consolidation :		-0.052 in	At test specimen vol :		225.51 cc	
Change in pipet vol due to consolidation :		5.6 cc	Initial dry density :		1.2322 pcf	
Saturation Parameter " B " =	0.97		At test dry density:		1.2322 pcf	
Strain Rate (in/min) =	0.0005	Failure Strain % =	8.5	Effective Cell Pressure (psi) =	10.0	
σ_1' Failure (psi) =	100.17	σ_1 Failure (psi) =	108.67	Estimated v =	0.35	
σ_3' Failure (psi) =	54.77	σ_3 Failure (psi) =	63.27	Back Pressure (psi) =	50.0	
ΔU =	3.3	Total Pore Pressure =	35.2	Cell Pressure (psi) =	90.0	

TRIAxIAL SHEAR TEST REPORT

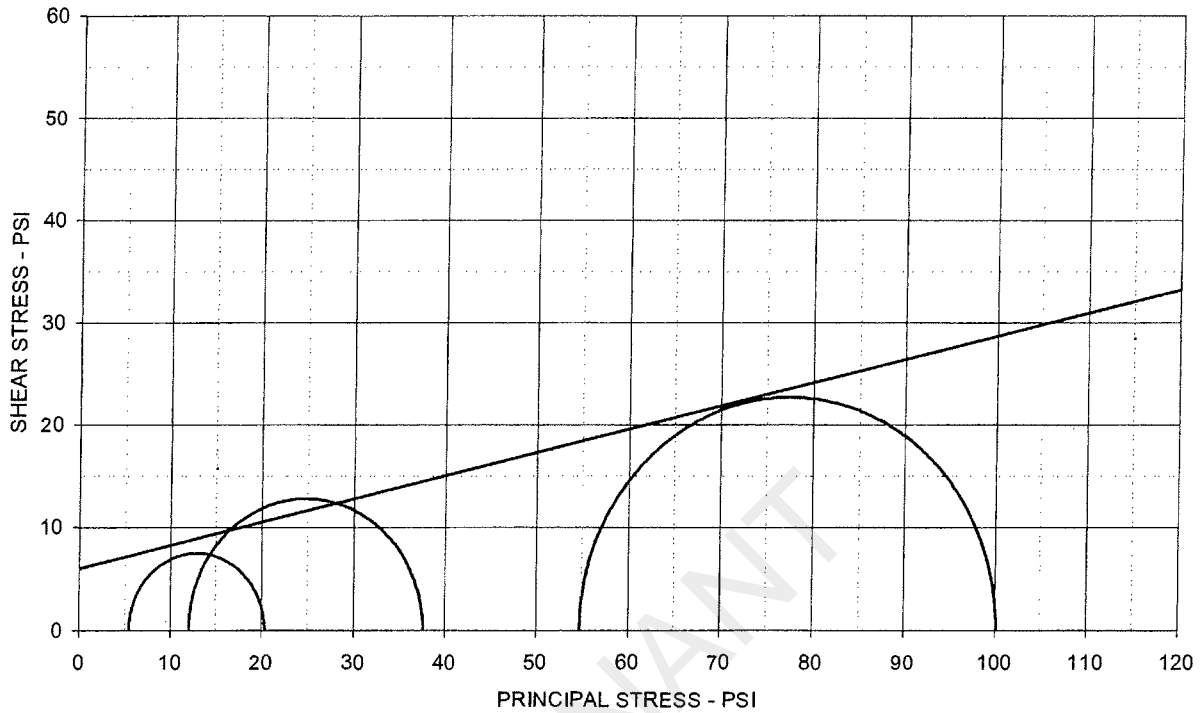

EFFECTIVE STRESS PARAMETERS

$\phi' = 12.8 \text{ deg}$

$c' = 6.0 \text{ psi}$

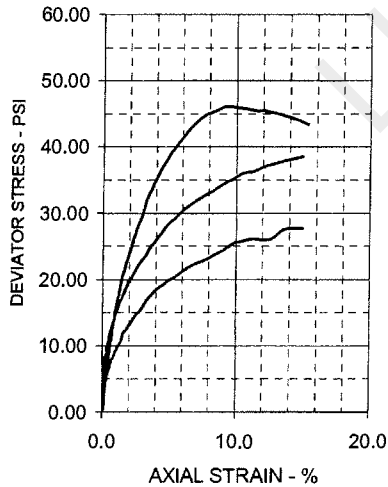

SPECIMEN NO.	1	2	3	4
INITIAL				
Moisture Content - %	15.8	16.6	15.9	
Dry Density - pcf	113.0	115.0	112.5	
Diameter - inches	2.04	2.01	2.06	
Height - inches	4.44	4.44	4.54	
AT TEST				
Final Moisture - %	18.1	18.1	17.6	
Dry Density - pcf	114.0	116.9	115.1	
Calculated Diameter (in.)	2.02	2.00	2.04	
Height - inches	4.40	4.40	4.49	
Effect. Cell Pressure - psi	10.0	20.0	40.0	
Failure Stress - psi	15.00	25.60	45.40	
Total Pore Pressure - psi	54.6	58.0	35.2	
Strain Rate - inches/min.	0.00050	0.00050	0.00050	
Failure Strain - %	2.7	3.9	8.5	
σ_1' Failure - psi	20.41	37.62	100.17	
σ_3' Failure - psi	5.41	12.02	54.77	

TEST DESCRIPTION

PROJECT INFORMATION

TYPE OF TEST & NO: CU with PP
 SAMPLE TYPE: Possible Fill Sample
 DESCRIPTION: Tan, Brown & Red Sandy Lean Clay
 Sampled on Site, B-13 3' to 10' deep
 ASSUMED SPECIFIC GRAVITY: 2.7 + 40 Sieve
 LL: PL: PI: Percent -200:
 REMARKS: Both Ends & Diameter Trimmed + # 4 Sieve
 © 2972-08, B-13, 3'-10' Fill

PROJECT: Luminant East Ash Disposal
 LOCATION: Rusk County, Texas
 PROJECT NO: G 2972 - 08
 CLIENT:
 November 2008

ETTL ENGINEERS & CONSULTANTS

PLATE: B.1

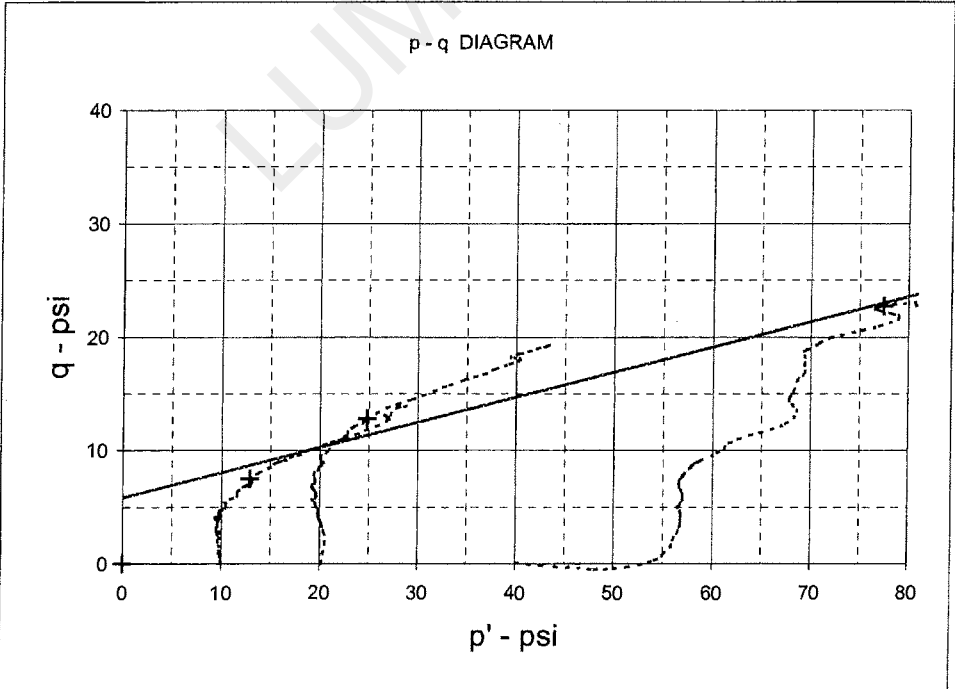
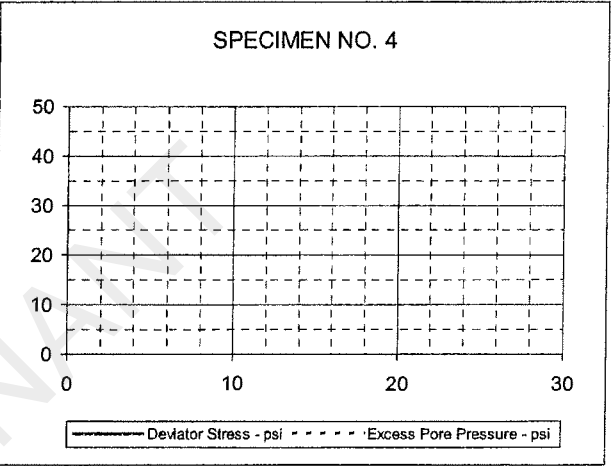
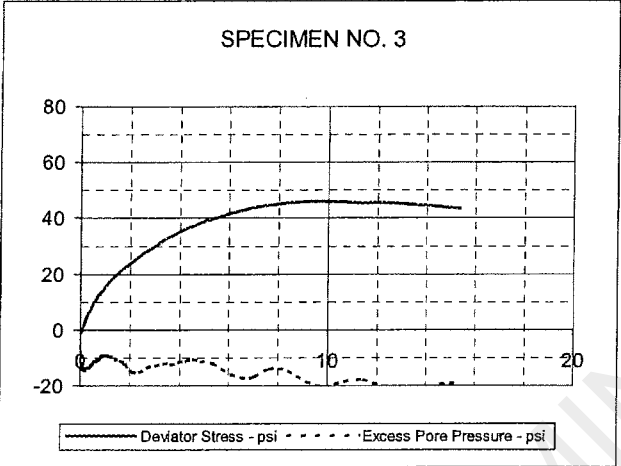
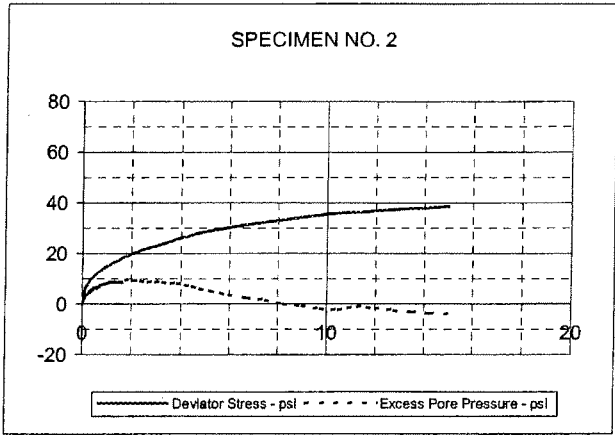
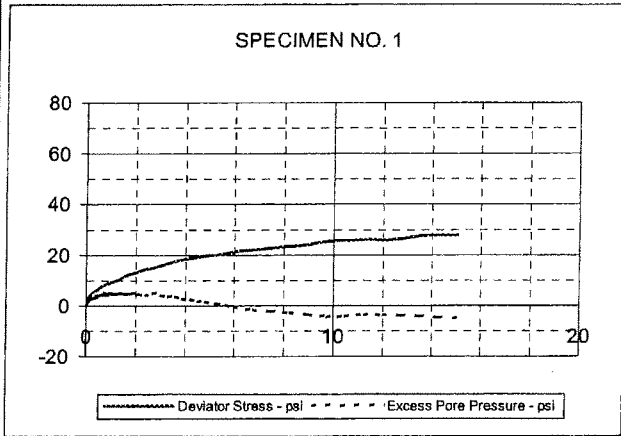

EFFECTIVE STRESS PARAMETERS	$R^2 = 0.97$	α (deg) = 12.5	a (psi) = 5.8
PROJECT: Luminant East Ash Disposal		TYPE OF TEST & NO: CU with PP	
PROJECT NO: G 2972 - 08		ETTL ENGINEERS & CONSULTANTS	PLATE: B.2
DESCRIPTION: Tan, Brown & Red Sandy Lean Clay			

G 2972-08, B-13, 3'-10' Fill

TRIAXIAL SHEAR TEST REPORT

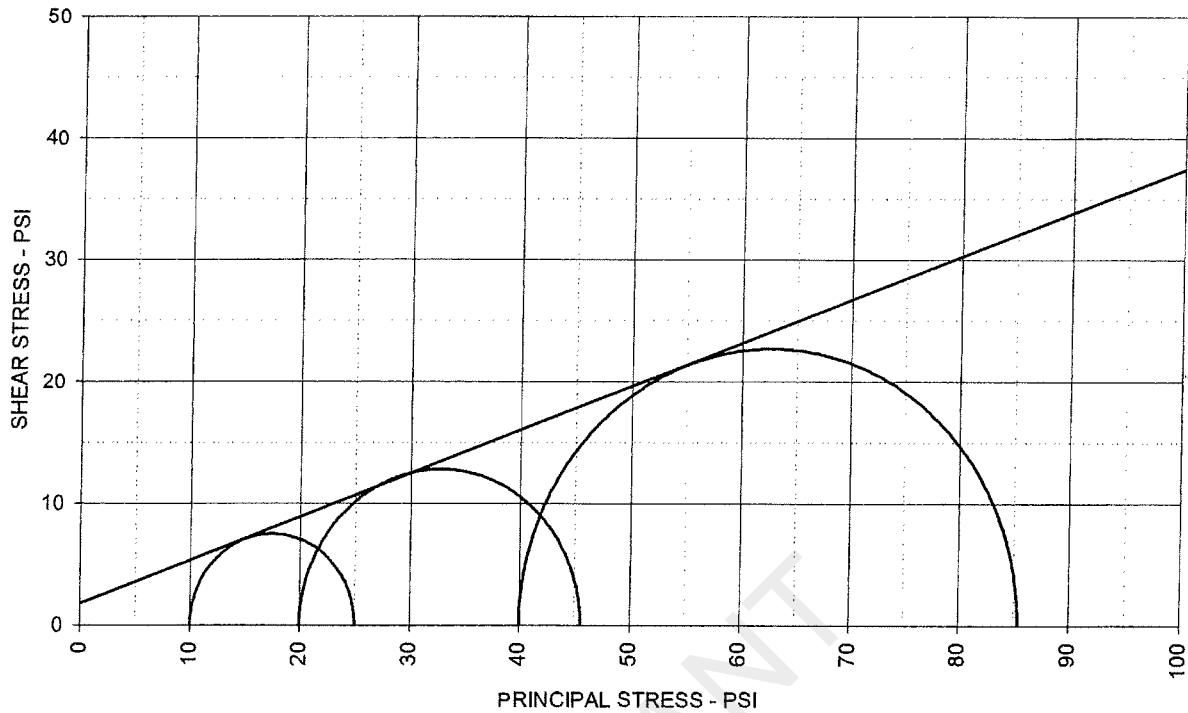

TOTAL STRESS PARAMETERS

$\phi = 19.6 \text{ deg}$

$c = 1.8 \text{ psi}$

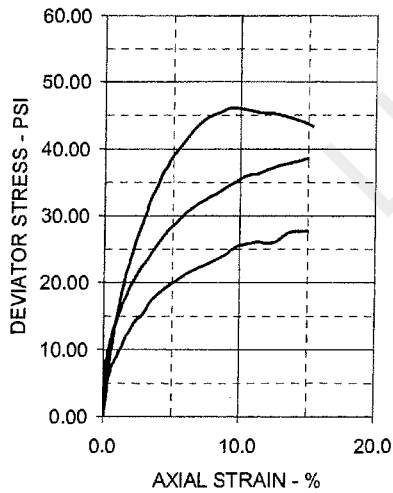

SPECIMEN NO.	1	2	3	4
INITIAL				
Moisture Content - %	15.8	16.6	15.9	
Dry Density - pcf	113.0	115.0	112.5	
Diameter - inches	2.04	2.01	2.06	
Height - Inches	4.44	4.44	4.54	
AT TEST				
Final Moisture - %	18.1	18.1	17.6	
Dry Density - pcf	114.0	116.9	115.1	
Calculated Diameter (In.)	2.02	2.00	2.04	
Height - inches	4.40	4.40	4.49	
Effect. Cell Pressure - psi	10.0	20.0	40.0	
Failure Stress - psi	15.00	25.60	45.40	
Total Pore Pressure - psi	54.6	58.0	35.2	
Strain Rate - Inches/min.	0.00050	0.00050	0.00050	
Failure Strain - %	2.7	3.9	8.5	
σ_1 Failure - psi	25.00	45.60	85.40	
σ_3 Failure - psi	10.00	20.00	40.00	

TEST DESCRIPTION

PROJECT INFORMATION

TYPE OF TEST & NO: CU with PP
 SAMPLE TYPE: Possible Fill Sample
 DESCRIPTION: Tan, Brown & Red Sandy Lean Clay
 Sampled on Site, B-13 3' to 10' deep
 ASSUMED SPECIFIC GRAVITY: 2.7 + 40 Sieve
 LL: PL: PI: Percent -200:
 REMARKS: Both Ends & Diameter Trimmed + # 4 Sieve

PROJECT: Luminant East Ash Disposal
 LOCATION: Rusk County, Texas
 PROJECT NO: G 2972 - 08
 CLIENT:
 November 2008

ETTL ENGINEERS & CONSULTANTS

PLATE: B.3

PROJECT INFORMATION

PROJECT: Luminant East Ash Disposal
LOCATION: Rock County, Texas
PROJECT NO: G 2872 - 08
CLIENT:
November 2008

TRIAxIAL TEST PROGRAM BY GARRY H. GREGORY, P.E.

ALL RIGHTS RESERVED - UNAUTHORIZED USE PROHIBITED
VERSION 1.0 - AUGUST 1998 - REVISED MARCH 24, 1999

THIS COPY LICENSED TO:
ETTL ENGINEERS AND CONSULTANTS, INC.
1717 East Erwin
Tyler, TX 75702

TEST DESCRIPTION

TYPE OF TEST & NO.: CU with PP
SAMPLE TYPE: Native Sample
DESCRIPTION: Gray, Tan & Redd Br Sandy Clay w/ some Gravel
Sampled on Site, B-2 @ 10' 20' (HMP)
ASSUMED SPECIFIC GRAVITY, 2.7 + 40 Sieve
LL: PL: PI: Percent-200:
REMARKS: Both Ends & Diameter Trimmed + # 4 Sieve

PLATE: B.1

PLATE: B.2

PLATE: B.3

Number of Specimens = 3

SPECIMEN DATA
SPECIMEN NO. 1

	initial	final	Diameter		Height	
Moist soil & Tare :	478.50 g	630.20 g	top	2.08 in	Ht 1	4.25 in
Dry soil and Tare :	429.60 g	548.70 g	mid	2.08 in	Ht 2	4.25 in
Tare :	129.70 g	128.00 g	bot	2.08 in	Ht 3	4.25 in
Moisture content :	19.57 %	19.32 %	Avg	2.08 in	Ht4	4.25 in
Weight:	496.8 g				Avg Ht	4.25 in
Change in Ht due to saturation :		-0.014 in	Initial specimen vol :		22.99 cc	
Change in Ht due to consolidation :		0.005 in	At test specimen vol :		23.3 cc	
Change in pipet vol due to consolidation :		0.8 cc	Initial dry density :		1.229 pcf	
Saturation Parameter " B " =	0.96		At test dry density:		1.257 pcf	
Strain Rate (in/min) =	0.0005	Failure Strain % =	2.4	Effective Cell Pressure (psi) =	30.0	
σ_1' Failure (psi) =	36.26	σ_1 Failure (psi) =	36.06	Estimated $v =$	0.35	
σ_3' Failure (psi) =	6.24	σ_3 Failure (psi) =	6.06	Back Pressure (psi) =	50.0	
$\Delta U =$	1.0	Total Pore Pressure =	51.8	Cell Pressure (psi) =	60.0	

SPECIMEN NO. 2

	initial	final	Diameter		Height	
Moist soil & Tare :	505.50 g	618.20 g	top	2.08 in	Ht 1	4.40 in
Dry soil and Tare :	451.40 g	537.80 g	mid	2.08 in	Ht 2	4.40 in
Tare :	114.00 g	102.60 g	bot	2.08 in	Ht 3	4.40 in
Moisture content :	18.05 %	16.32 %	Avg	2.08 in	Ht4	4.40 in
Weight:	511.6 g				Avg Ht	4.40 in
Change in Ht due to saturation :		0.01 in	Initial specimen vol :		23.0 cc	
Change in Ht due to consolidation :		-0.048 in	At test specimen vol :		23.0 cc	
Change in pipet vol due to consolidation :		7.0 cc	Initial dry density :		1.229 pcf	
Saturation Parameter " B " =	0.98		At test dry density:		1.257 pcf	
Strain Rate (in/min) =	0.0005	Failure Strain % =	3.4	Effective Cell Pressure (psi) =	30.0	
σ_1' Failure (psi) =	48.53	σ_1 Failure (psi) =	48.06	Estimated $v =$	0.35	
σ_3' Failure (psi) =	13.88	σ_3 Failure (psi) =	13.60	Back Pressure (psi) =	50.0	
$\Delta U =$	8.0	Total Pore Pressure =	58.1	Cell Pressure (psi) =	70.0	

SPECIMEN NO. 3

	initial	final	Diameter		Height	
Moist soil & Tare :	414.70 g	721.60 g	top	2.11 in	Ht 1	4.62 in
Dry soil and Tare :	381.70 g	652.20 g	mid	2.11 in	Ht 2	4.62 in
Tare :	102.50 g	136.10 g	bot	2.11 in	Ht 3	4.62 in
Moisture content :	18.05 %	16.32 %	Avg	2.11 in	Ht4	4.62 in
Weight:	579.6 g				Avg Ht	4.62 in
Change in Ht due to saturation :		-0.02 in	Initial specimen vol :		24.0 cc	
Change in Ht due to consolidation :		-0.018 in	At test specimen vol :		24.0 cc	
Change in pipet vol due to consolidation :		5.4 cc	Initial dry density :		1.229 pcf	
Saturation Parameter " B " =	0.99		At test dry density:		1.257 pcf	
Strain Rate (in/min) =	0.0005	Failure Strain % =	4.6	Effective Cell Pressure (psi) =	30.0	
σ_1' Failure (psi) =	95.08	σ_1 Failure (psi) =	94.29	Estimated $v =$	0.35	
σ_3' Failure (psi) =	25.40	σ_3 Failure (psi) =	25.00	Back Pressure (psi) =	50.0	
$\Delta U =$	14.0	Total Pore Pressure =	64.5	Cell Pressure (psi) =	90.0	

TRIAxIAL SHEAR TEST REPORT

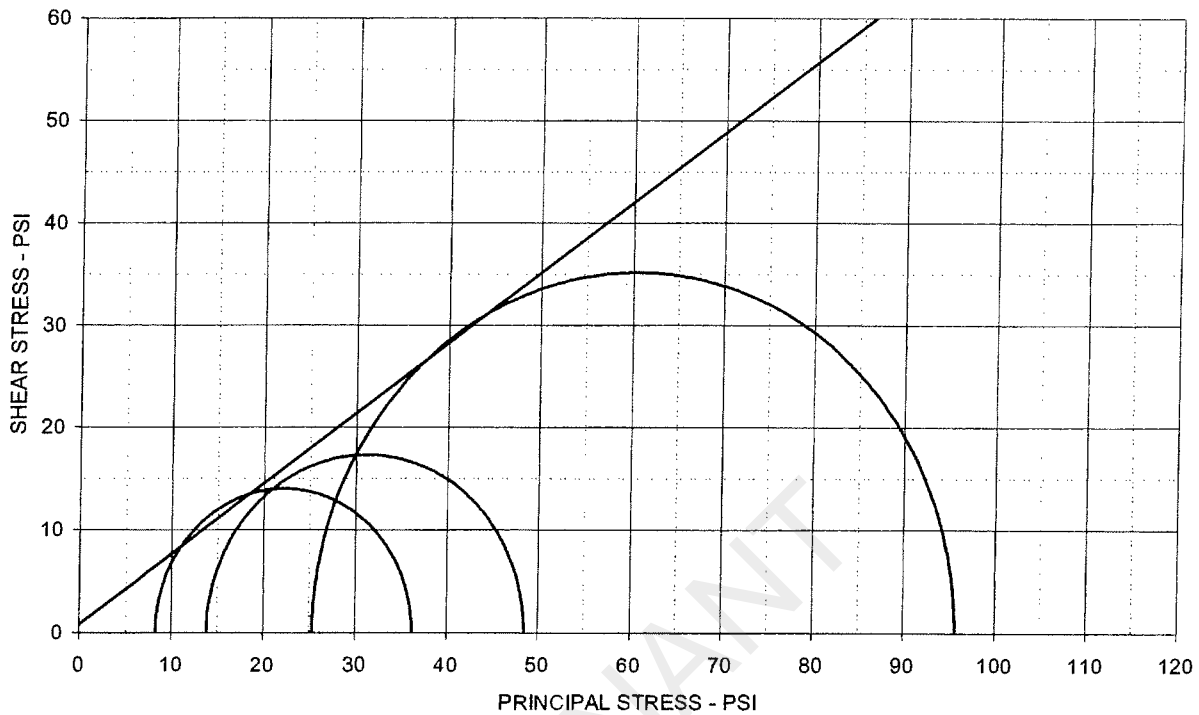

EFFECTIVE STRESS PARAMETERS

$\phi' = 34.4 \text{ deg}$

$c' = 0.8 \text{ psi}$

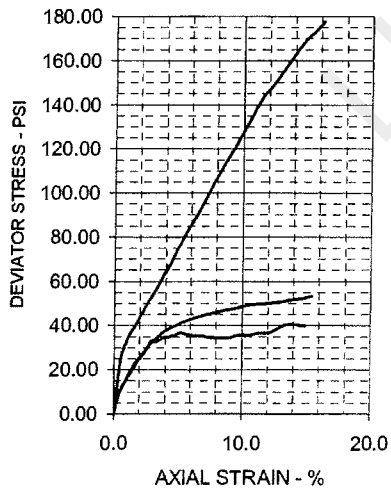

SPECIMEN NO.

1 2 3 4

INITIAL

Moisture Content - %	16.6	16.0	11.8
Dry Density - pcf	112.3	112.1	122.3
Diameter - inches	2.08	2.08	2.11
Height - inches	4.25	4.40	4.62

AT TEST

Final Moisture - %	19.4	18.1	13.5
Dry Density - pcf	112.6	115.3	124.9
Calculated Diameter (in.)	2.08	2.07	2.10
Height - inches	4.24	4.37	4.58
Effect. Cell Pressure - psi	10.0	20.0	40.0
Failure Stress - psi	28.02	34.65	70.28
Total Pore Pressure - psi	51.8	56.1	64.6
Strain Rate - inches/min.	0.00050	0.00050	0.00050
Failure Strain - %	2.4	3.4	4.6
σ_1' Failure - psi	36.26	48.53	95.68
σ_3' Failure - psi	8.24	13.88	25.40

TEST DESCRIPTION

PROJECT INFORMATION

TYPE OF TEST & NO: CU with PP
 SAMPLE TYPE: Native Sample
 DESCRIPTION: Gray, Tan & Redd. Br Sandy Clay w/ some Gravel
 Sampled on Site, B-2 8' to 20' deep
 ASSUMED SPECIFIC GRAVITY: 2.7 + 40 Sieve
 LL: PL: PI: Percent -200:
 REMARKS: Both Ends & Diameter Trimmed + # 4 Sieve
 G 2972-08, B-2, 0' to 20' Native

PROJECT: Luminant East Ash Disposal
 LOCATION: Rusk County, Texas
 PROJECT NO: G 2972 - 08
 CLIENT:
 November 2008

ETTL ENGINEERS & CONSULTANTS

PLATE: B.1

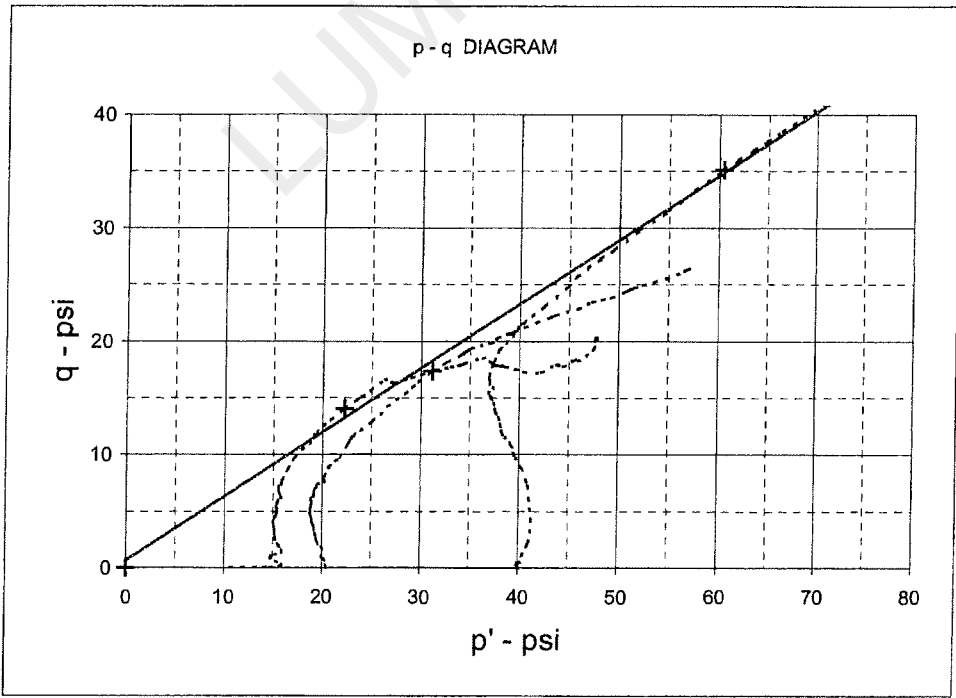
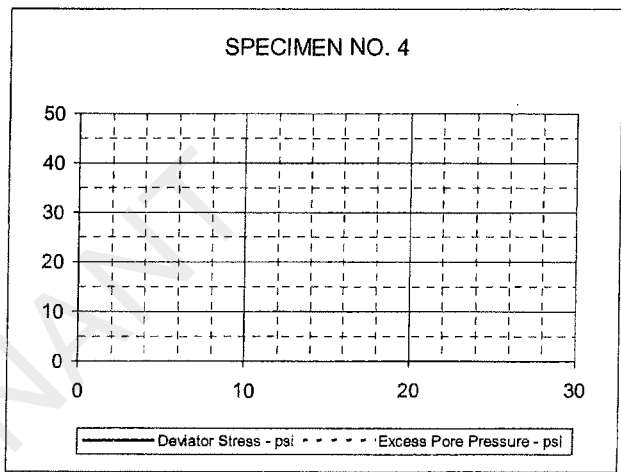
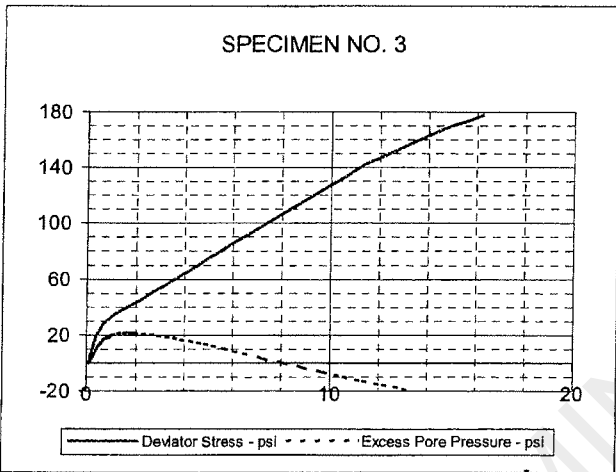
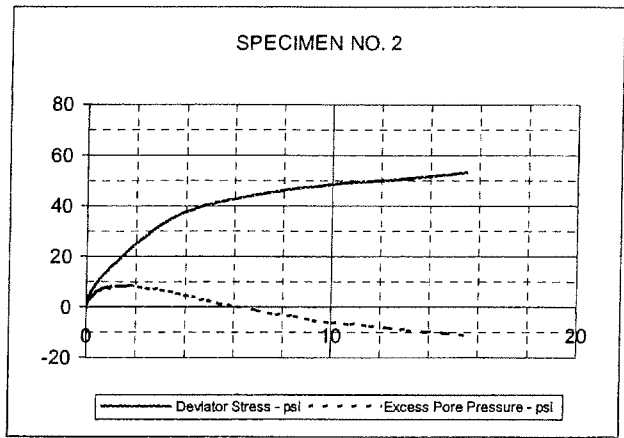
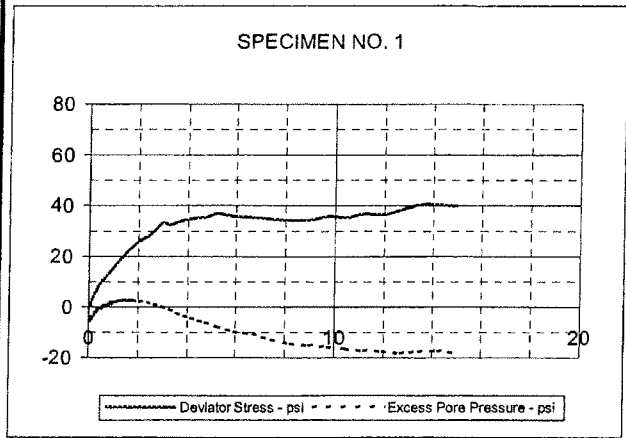

EFFECTIVE STRESS PARAMETERS	$R^2 = 0.99$	α (deg) = 29.5	a (psi) = 0.7
PROJECT: Luminant East Ash Disposal		TYPE OF TEST & NO: CU with PP	
PROJECT NO: G 2972 - 08		ETTL ENGINEERS & CONSULTANTS	PLATE: B.2
DESCRIPTION: Gray, Tan & Redd. Br Sandy Clay w/ some Gravel			

G 2972-08, B-2, 8'-20' Native

TRIAxIAL SHEAR TEST REPORT

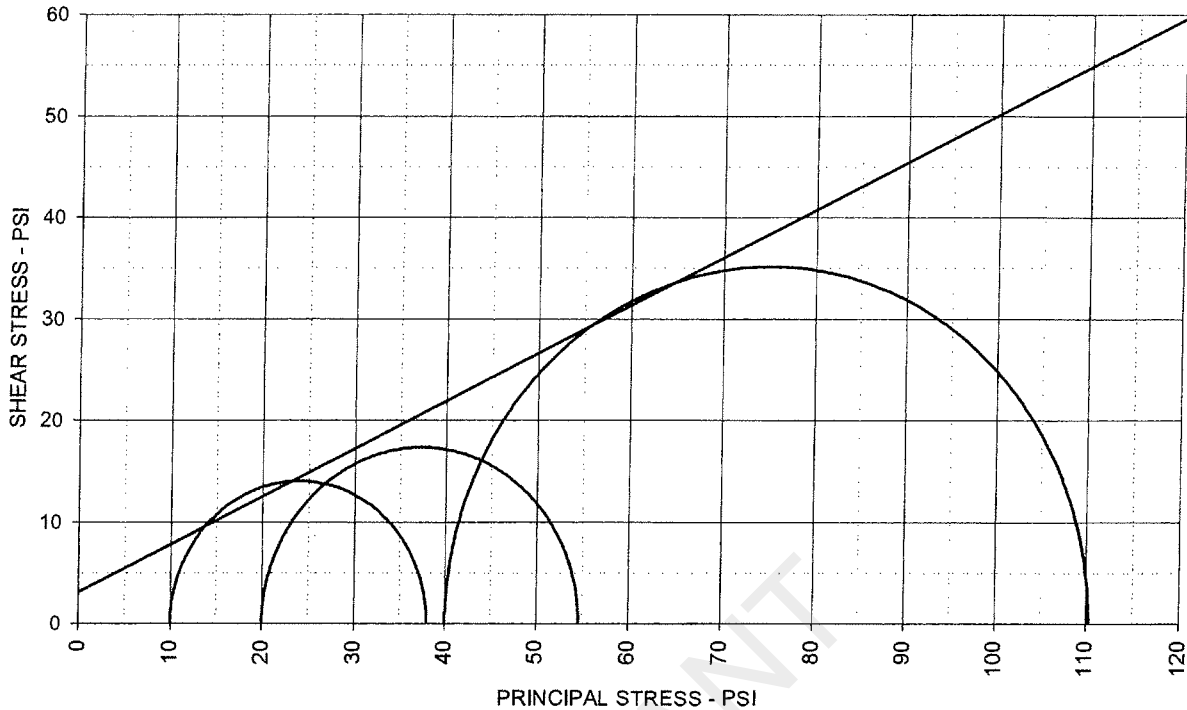

TOTAL STRESS PARAMETERS

$\phi = 25.2 \text{ deg}$

$c = 3.1 \text{ psi}$

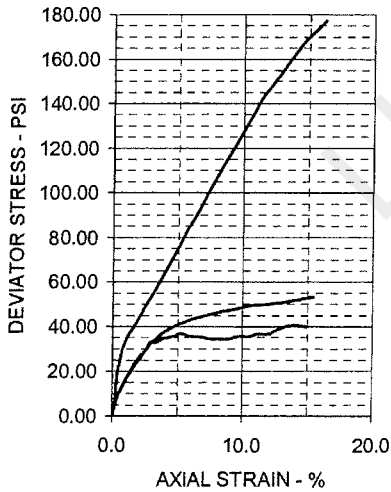

SPECIMEN NO.	1	2	3	4
INITIAL				
Moisture Content - %	16.6	16.0	11.8	
Dry Density - pcf	112.3	112.1	122.3	
Diameter - inches	2.08	2.08	2.11	
Height - inches	4.25	4.40	4.62	
AT TEST				
Final Moisture - %	19.4	18.1	13.5	
Dry Density - pcf	112.6	115.3	124.9	
Calculated Diameter (in.)	2.08	2.07	2.10	
Height - inches	4.24	4.37	4.58	
Effect. Cell Pressure - psi	10.0	20.0	40.0	
Failure Stress - psi	28.02	34.65	70.28	
Total Pore Pressure - psi	51.8	56.1	64.6	
Strain Rate - inches/min.	0.00050	0.00050	0.00050	
Failure Strain - %	2.4	3.4	4.6	
σ_1 Failure - psi	38.02	54.65	110.28	
σ_3 Failure - psi	10.00	20.00	40.00	

TEST DESCRIPTION

TYPE OF TEST & NO: CU with PP
 SAMPLE TYPE: Native Sample
 DESCRIPTION: Gray, Tan & Redd. Br Sandy Clay w/ some Gravel
 Sampled on Site, B-2 8' to 20' deep
 ASSUMED SPECIFIC GRAVITY: 2.7 + 40 Sieve
 LL: PL: PI: Percent -200:
 REMARKS: Both Ends & Diameter Trimmed + # 4 Sieve

PROJECT INFORMATION

PROJECT: Luminant East Ash Disposal
 LOCATION: Rusk County, Texas
 PROJECT NO: G 2972 - 08
 CLIENT:
 November 2008

ETTL ENGINEERS & CONSULTANTS

PLATE: B.3

PROJECT INFORMATION

PROJECT: Luminant East Ash Disposal
LOCATION: Rusk County, Texas
PROJECT NO: G 2972 - 05
CLIENT:
November, 2008

TRIAxIAL TEST PROGRAM BY GARRY H. GREGORY, P.E.

ALL RIGHTS RESERVED - UNAUTHORIZED USE PROHIBITED
VERSION 1.0 - AUGUST 1998 - REVISED MARCH 24, 1999

THIS COPY LICENSED TO:
ETTL ENGINEERS AND CONSULTANTS, INC.
1717 East Erwin
Tyler, TX 75702

TEST DESCRIPTION

TYPE OF TEST & NO: CU - 40 PP
SAMPLE TYPE: Possible Fe Sample
DESCRIPTION: Tan & Red Sandy Lean Clay w/ Rocks
Sampled on Site, 8-1' 3" to 10' deep
ASSUMED SPECIFIC GRAVITY: 2.7 + 40 Sieve
LL PL Pt Percent 200
REMARKS: Both Ends & Diameter Trimmed + 4 Sieve

PLATE: B.1

PLATE: B.2

PLATE: B.3

Number of Specimens = 3

SPECIMEN DATA

SPECIMEN NO. 1

	initial	final	Diameter		Height	
Moist soil & Tare :	539.50 g	625.10 g	top	2.07 in	Ht 1	4.23 in
Dry soil and Tare :	452.00 g	548.00 g	mid	2.07 in	Ht 2	4.23 in
Tare :	127.40 g	126.90 g	bot	2.07 in	Ht 3	4.23 in
Moisture content :	15.16 %	15.31 %	Avg	2.07 in	Ht4	4.23 in
Weight:	482.2 g				Avg Ht	4.23 in
Change in Ht due to saturation :		0.02 in	Initial specimen vol :		295.1 cc	
Change in Ht due to consolidation :		-0.006 in	At test specimen vol :		297.0 cc	
Change in pipet vol due to consolidation :		3.2 cc	Initial dry density :		1.12 pcf	
Saturation Parameter " B " =	0.97		At test dry density:		1.15 pcf	
Strain Rate (in/min) =	0.0005	Failure Strain % =	1.4	Effective Cell Pressure (psi) =	10.0	
σ_1 ' Failure (psi) =	29.29	σ_1 Failure (psi) =	32.98	Estimated v =	0.35	
σ_3 ' Failure (psi) =	6.55	σ_3 Failure (psi) =	13.10	Back Pressure (psi) =	50.0	
ΔU =	3.3	Total Pore Pressure =	53.7	Cell Pressure (psi) =	60.0	

SPECIMEN NO. 2

	initial	final	Diameter		Height	
Moist soil & Tare :	548.00 g	594.00 g	top	2.01 in	Ht 1	4.25 in
Dry soil and Tare :	492.70 g	519.10 g	mid	2.01 in	Ht 2	4.25 in
Tare :	136.60 g	124.60 g	bot	2.01 in	Ht 3	4.25 in
Moisture content :	16.53 %	16.23 %	Avg	2.01 in	Ht4	4.25 in
Weight:	462.2 g				Avg Ht	4.25 in
Change in Ht due to saturation :		-0.009 in	Initial specimen vol :		293.0 cc	
Change in Ht due to consolidation :		-0.033 in	At test specimen vol :		297.0 cc	
Change in pipet vol due to consolidation :		4.2 cc	Initial dry density :		1.12 pcf	
Saturation Parameter " B " =	0.99		At test dry density:		1.15 pcf	
Strain Rate (in/min) =	0.0005	Failure Strain % =	3.0	Effective Cell Pressure (psi) =	10.0	
σ_1 ' Failure (psi) =	40.52	σ_1 Failure (psi) =	45.75	Estimated v =	0.35	
σ_3 ' Failure (psi) =	14.53	σ_3 Failure (psi) =	21.02	Back Pressure (psi) =	50.0	
ΔU =	5.8	Total Pore Pressure =	55.5	Cell Pressure (psi) =	70.0	

SPECIMEN NO. 3

	initial	final	Diameter		Height	
Moist soil & Tare :	431.00 g	628.40 g	top	2.10 in	Ht 1	4.25 in
Dry soil and Tare :	385.90 g	558.90 g	mid	2.10 in	Ht 2	4.25 in
Tare :	105.00 g	139.45 g	bot	2.10 in	Ht 3	4.25 in
Moisture content :	17.15 %	15.29 %	Avg	2.10 in	Ht4	4.25 in
Weight:	510.5 g				Avg Ht	4.25 in
Change in Ht due to saturation :		-0.017 in	Initial specimen vol :		297.0 cc	
Change in Ht due to consolidation :		-0.039 in	At test specimen vol :		297.0 cc	
Change in pipet vol due to consolidation :		4.6 cc	Initial dry density :		1.12 pcf	
Saturation Parameter " B " =	0.97		At test dry density:		1.15 pcf	
Strain Rate (in/min) =	0.0005	Failure Strain % =	3.0	Effective Cell Pressure (psi) =	10.0	
σ_1 ' Failure (psi) =	104.13	σ_1 Failure (psi) =	101.42	Estimated v =	0.35	
σ_3 ' Failure (psi) =	42.71	σ_3 Failure (psi) =	40.00	Back Pressure (psi) =	50.0	
ΔU =	2.2	Total Pore Pressure =	47.3	Cell Pressure (psi) =	90.0	

TRIAXIAL SHEAR TEST REPORT

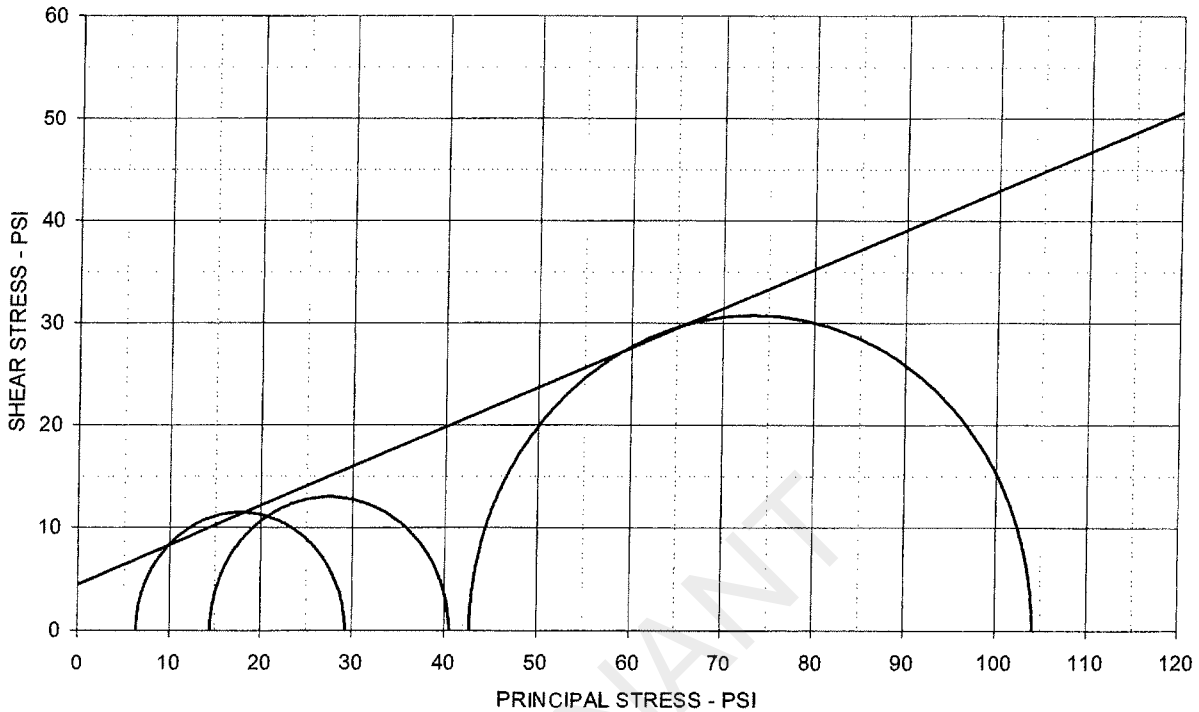

EFFECTIVE STRESS PARAMETERS

$\phi' = 21.0 \text{ deg}$ $c' = 4.5 \text{ psi}$

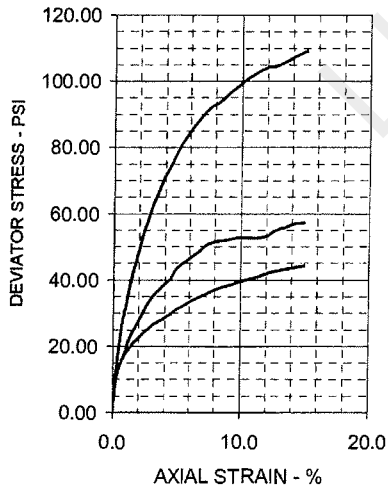

SPECIMEN NO.	1	2	3	4
INITIAL				
Moisture Content - %	16.2	15.5	16.1	
Dry Density - pcf	113.6	113.1	113.3	
Diameter - Inches	2.07	2.01	2.10	
Height - Inches	4.23	4.25	4.28	
AT TEST				
Final Moisture - %	18.3	18.2	15.8	
Dry Density - pcf	115.2	115.3	115.5	
Calculated Diameter (in.)	2.08	1.99	2.08	
Height - inches	4.24	4.21	4.22	
Effect. Cell Pressure - psi	10.0	20.0	40.0	
Failure Stress - psi	22.94	25.99	61.42	
Total Pore Pressure - psi	53.7	55.5	47.3	
Strain Rate - Inches/min.	0.00050	0.00050	0.00050	
Failure Strain - %	1.4	3.0	3.0	
σ_1' Failure - psi	29.29	40.52	104.13	
σ_3' Failure - psi	6.35	14.53	42.71	

TEST DESCRIPTION

PROJECT INFORMATION

TYPE OF TEST & NO: CU with PP
 SAMPLE TYPE: Possible Fill Sample
 DESCRIPTION: Tan & Red Sandy Lean Clay w/ Roots
 Sampled on Site, B-1 3' to 10' deep
 ASSUMED SPECIFIC GRAVITY: 2.7 + 40 Sieve
 LL: PL: Pi: Percent -200:
 REMARKS: Both Ends & Diameter Trimmed + # 4 Sieve
 G 2972-00, B-1, 3'-10' Fill

PROJECT: Luminant East Ash Disposal
 LOCATION: Rusk County, Texas
 PROJECT NO: G 2972 - 08
 CLIENT:
 November 2008

ETTL ENGINEERS & CONSULTANTS

PLATE: B.1

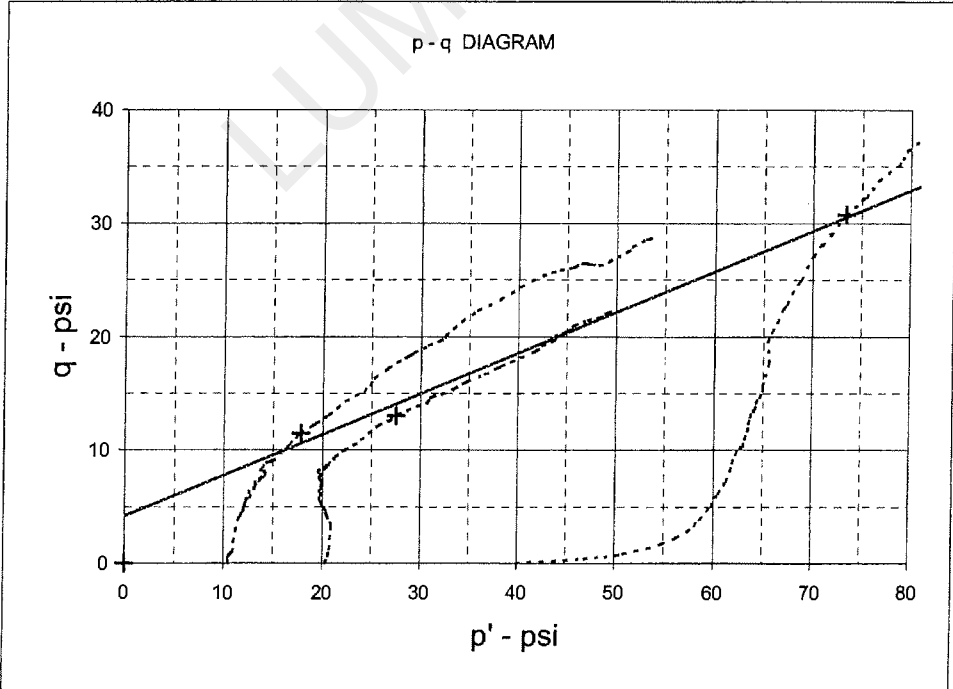
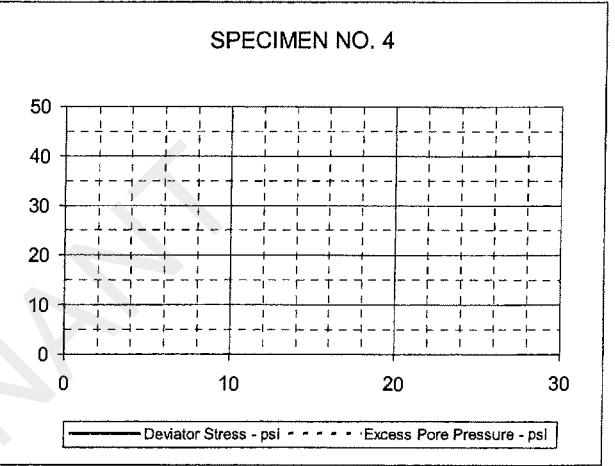
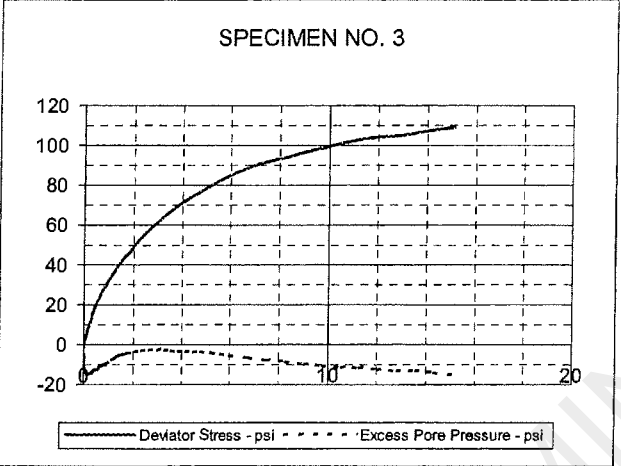
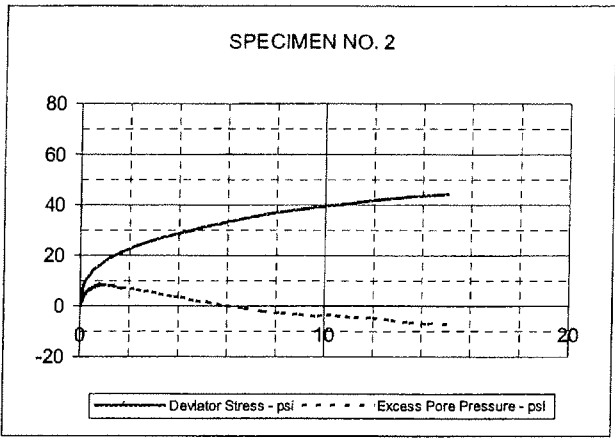
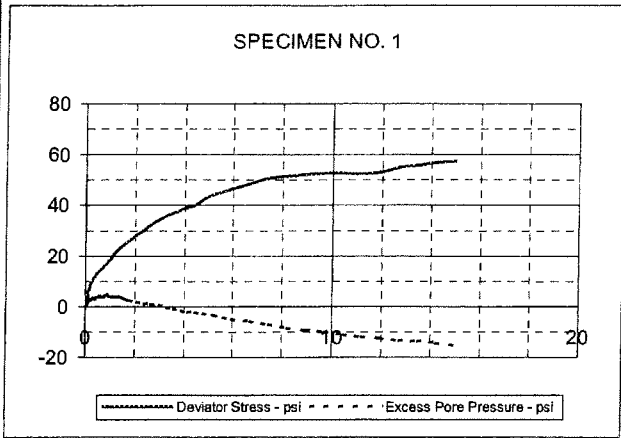

EFFECTIVE STRESS PARAMETERS	$R^2 = 0.99$	α (deg) = 19.7	a (psi) = 4.2
PROJECT: Luminant East Ash Disposal		TYPE OF TEST & NO: CU with PP	
PROJECT NO: G 2972 - 08		ETTL ENGINEERS & CONSULTANTS	PLATE: B.2
DESCRIPTION: Tan & Red Sandy Lean Clay w/ Roots			

G 2972-08, B-1, 3'-10' Fill

TRIAxIAL SHEAR TEST REPORT

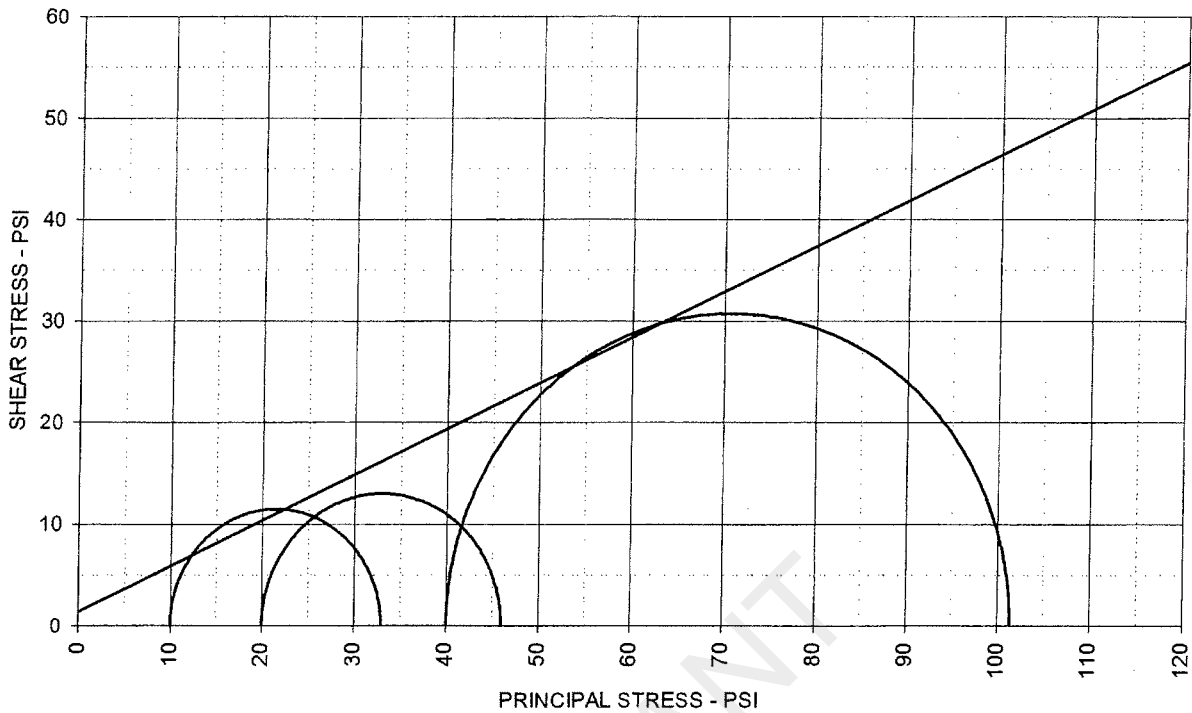

TOTAL STRESS PARAMETERS

$\phi = 24.2 \text{ deg}$

$c = 1.4 \text{ psi}$

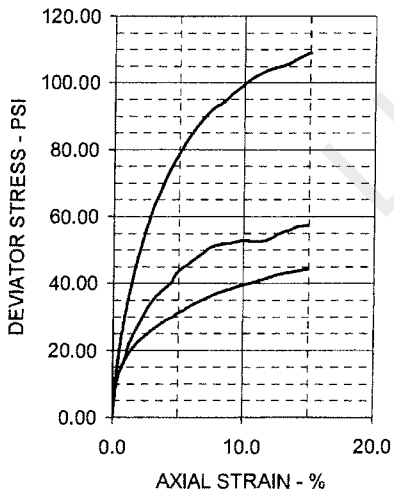

SPECIMEN NO.	1	2	3	4
INITIAL				
Moisture Content - %	16.2	15.5	16.1	
Dry Density - pcf	113.6	113.1	113.3	
Diameter - inches	2.07	2.01	2.10	
Height - inches	4.23	4.25	4.28	
AT TEST				
Final Moisture - %	18.3	18.2	15.8	
Dry Density - pcf	115.2	115.3	115.5	
Calculated Diameter (in.)	2.08	1.99	2.08	
Height - Inches	4.24	4.21	4.22	
Effect. Cell Pressure - psi	10.0	20.0	40.0	
Failure Stress - psi	22.94	25.99	61.42	
Total Pore Pressure - psi	53.7	55.5	47.3	
Strain Rate - Inches/min.	0.00050	0.00050	0.00050	
Failure Strain - %	1.4	3.0	3.0	
σ_1 Failure - psi	32.94	45.99	101.42	
σ_3 Failure - psi	10.00	20.00	40.00	

TEST DESCRIPTION

TYPE OF TEST & NO: CU with PP
 SAMPLE TYPE: Possible Fill Sample
 DESCRIPTION: Tan & Red Sandy Lean Clay w/ Roots
 Sampled on Site, B-1 3' to 10' deep
 ASSUMED SPECIFIC GRAVITY: 2.7 + 40 Sieve
 LL: PL: PI: Percent -200:
 REMARKS: Both Ends & Diameter Trimmed + # 4 Sieve

PROJECT INFORMATION

PROJECT: Luminant East Ash Disposal
 LOCATION: Rusk County, Texas
 PROJECT NO: G 2972 - 08
 CLIENT:
 November 2008

ETTL ENGINEERS & CONSULTANTS

PLATE: B.3

PERMANENT DISPOSAL POND - 5

LUMINANT

HYDROMETER AND MECHANICAL ANALYSIS OF SOIL BINDER, ASTM D422

PROJECT: Luminant Martin Lake, PDP 1-3
CLIENT: TXU
CONTRACTOR: not given
JOB No. : G 2810 - 08

REPORT No.:
DATE SAMPLED: February 2008
SAMPLED BY: E TTL Drill Crew
LOCATION: MLSES
SAMPLE No. :
DESCRIPTION: Gray & Dark Gray Bottom Ash
TECHNICIAN: M. Thompson
DATE: 04/15/08

RESULTS

Grain Diameter	% Retain
+2.0 mm	47.69
+0.05 mm	99.26
0.05 to 2.0 mm	51.57
0.002 to 0.05 mm	0.72
> 0.002 mm	0.02

WEIGHT OF SAMPLE (AIR DRY)	100.00
WEIGHT OF SAMPLE (OVEN DRY)	99.90
PERCENT RETAINED ON # 10	47.69
SPECIFIC GRAVITY	2.563

	SIEVE	WEIGHT	%RETAIN	GRAIN DIA	%PASSING
Mc Hydrom	40	54.66	76.31	0.425	23.69
Tare Wt	29.89	60	71.63	0.250	14.80
Wet Wt.	68.94	100	84.45	0.150	8.09
Dry Wt	68.90	140	90.93	0.105	4.70
MC	0.1025%	200	93.54	0.075	3.33

TEMP (C)	HYDROMETER CORRECTION	HYDROMETER READING	CORRECTED READING	L.Hydrom FACTOR	K. Diam. FACTOR	a. SP.GR. FACTOR	TIME (MIN)	GRAIN DIA (MM)	% SOIL PASSING
21.5	5.7	11.0	5.3	15.5	0.0141	1.02	0.5	0.0787	2.82
21.5	5.7	8.0	2.3	16	0.0141	1.02	1	0.0566	1.21
21.5	5.7	6.8	1.1	16.1	0.0141	1.02	2	0.0401	0.57
21.5	5.7	6.2	0.5	16.3	0.0141	1.02	5	0.0255	0.25
21.5	5.7	6.0	0.3	16.3	0.0141	1.02	15	0.0147	0.15
21.5	5.7	5.8	0.1	16.3	0.0141	1.02	30	0.0104	0.04
21.5	5.7	5.8	0.1	16.3	0.0141	1.02	60	0.0074	0.04
21.5	5.7	5.8	0.1	16.3	0.0141	1.02	250	0.0036	0.04
22.0	5.6	5.6	0.0	16.3	0.0140	1.02	1440	0.0015	0.02

SPECIFIC GRAVITY	BOTTLE #	Bottle Wt	Bott & Water	WaterTemp	Corr. Soil	Bott, S & Water	WaterTemp	Specif. Grav	
Air dry Sample(gr)	100	10	188.06	686.13	22.5	99.90	747.18	21.5	2.563

Sieve % Pass	Sieve Size	Grams Retain	% Pass
	2"	0.00	100.00
	1-1/2"	89.00	98.47
Air Dry Start Wt.:	1"	215.04	96.31
5836.8	3/4"	288.14	95.06
Dry Start Wt.:	3/8"	709.78	87.83
5830.82	No 4	1510.97	74.09
	No 10	2780.46	52.31

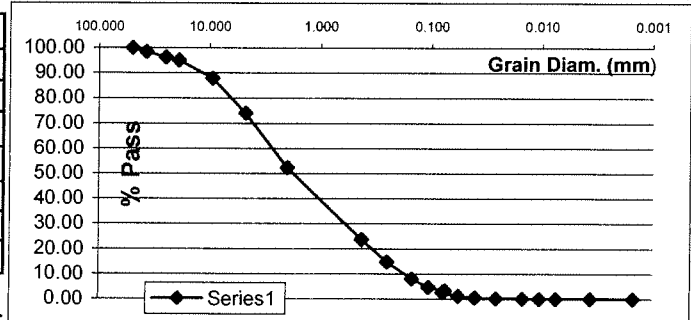

Remarks:

HYDROMETER AND MECHANICAL ANALYSIS OF SOIL BINDER, ASTM D422

PROJECT: Luminant Martin Lake, PDP 1-3
CLIENT: TXU
CONTRACTOR: not given
JOB No. : G 2810 - 08

REPORT No.:

DATE SAMPLED: February 2008
SAMPLED BY: E TTL Drill Crew
LOCATION: B-9, 1'-3'
SAMPLE No. :
DESCRIPTION: Gray Ash (Cementing)
TECHNICIAN: H. Walka
DATE: 03/14/08

RESULTS

	Grain Diameter	
% Retain	+2.0 mm	0.08
% Retain	+0.05 mm	41.35
% Passing	0.05 to 2.0 mm	41.27
% Passing	0.002 to 0.05 mm	56.63
% Passing	> 0.002 mm	2.02

WEIGHT OF SAMPLE (AIR DRY)	100.00
WEIGHT OF SAMPLE (OVEN DRY)	99.73
PERCENT RETAINED ON # 10	0.08
SPECIFIC GRAVITY	2.761

	SIEVE	WEIGHT	%RETAIN	GRAIN DIA	%PASSING
Mc Hydrom	40	0.92	1.00	0.425	99.00
Tare Wt	29.50	60	1.92	0.250	98.00
Wet Wt.	62.41	100	3.90	0.150	96.01
Dry Wt	62.32	140	7.07	0.105	92.84
MC	0.2742%	200	10.67	0.075	89.23

TEMP (C)	HYDROMETER CORRECTION	HYDROMETER READING	CORRECTED READING	L.Hydrom FACTOR	K. Diam. FACTOR	a. SP.GR. FACTOR	TIME (MIN)	GRAIN DIA (MM)	% SOIL PASSING
23.0	5.2	65.0	59.8	6.6	0.0138	0.98	0.5	0.0502	58.67
23.0	5.2	63.0	57.8	7	0.0138	0.98	1	0.0365	56.71
23.0	5.2	53.0	47.8	8.6	0.0138	0.98	2	0.0286	46.89
23.0	5.2	32.0	26.8	12	0.0138	0.98	5	0.0214	26.27
22.5	5.4	10.0	4.6	15.6	0.0140	0.98	15	0.0142	4.51
22.5	5.4	8.5	3.1	15.8	0.0140	0.98	30	0.0101	3.04
22.5	5.4	8.0	2.6	16	0.0140	0.98	60	0.0072	2.55
22.0	5.6	8.0	2.4	16	0.0140	0.98	250	0.0035	2.39
22.0	5.6	7.5	1.9	16.1	0.0140	0.98	1440	0.0015	1.90

SPECIFIC GRAVITY	BOTTLE #	Bottle Wt	Bott & Water	WaterTemp	Corr. Soil	Bott, S & Water	WaterTemp	Specif. Grav	
Air dry Sample(gr)	50	7	179.97	678.12	22.5	49.86	709.93	22.5	2.761

Sieve % Pass	Sieve Size	Grams Retain	% Pass
	1-1/2"	0.00	100.00
Air Dry Start Wt.:	1"	0.00	100.00
334.9	3/4"	0.00	100.00
Dry Start Wt.:	3/8"	0.00	100.00
333.98	No 4	0.00	100.00
	No 10	0.26	99.92

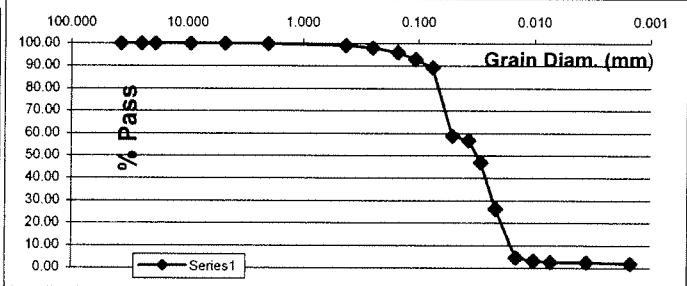

Remarks:

HYDROMETER AND MECHANICAL ANALYSIS OF SOIL BINDER, ASTM D422

PROJECT: Luminant Martin Lake, PDP 1-3
CLIENT: TXU
CONTRACTOR: not given
JOB No. : G 2810 - 08

REPORT No.:
DATE SAMPLED: February 2008
SAMPLED BY: E TTL Drill Crew
LOCATION: B-7, 13'-15'
SAMPLE No. :
DESCRIPTION: Gray Ash
TECHNICIAN: H. Walka
DATE: 03/14/08

RESULTS

Grain Diameter	% Retain
+2.0 mm	59.89
+0.05 mm	92.28
0.05 to 2.0 mm	32.39
0.002 to 0.05 mm	4.63
> 0.002 mm	3.09

WEIGHT OF SAMPLE (AIR DRY)	50.00
WEIGHT OF SAMPLE (OVEN DRY)	49.81
PERCENT RETAINED ON # 10	59.89
SPECIFIC GRAVITY	2.655

	SIEVE	WEIGHT	%RETAIN	GRAIN DIA	%PASSING
Mc Hydrom	40	25.25	80.22	0.425	19.78
Tare Wt	30.03	60	29.25	0.250	16.56
Wet Wt.	45.86	100	32.74	0.150	13.75
Dry Wt.	45.80	140	35.11	0.105	11.84
MC	0.3805%	200	36.67	0.075	10.58

TEMP (C)	HYDROMETER CORRECTION	HYDROMETER READING	CORRECTED READING	L.Hydrom FACTOR	K. Diam. FACTOR	a. SP.GR. FACTOR	TIME (MIN)	GRAIN DIA (MM)	% SOIL PASSING
22.0	5.6	17.5	11.9	14.5	0.0140	1.00	0.5	0.0752	9.61
22.0	5.6	15.5	9.9	14.8	0.0140	1.00	1	0.0537	8.00
22.0	5.6	14.0	8.4	15	0.0140	1.00	2	0.0383	6.79
22.0	5.6	13.5	7.9	15.2	0.0140	1.00	5	0.0244	6.39
22.0	5.6	13.0	7.4	15.2	0.0140	1.00	15	0.0141	5.99
21.5	5.7	12.5	6.8	15.3	0.0141	1.00	30	0.0101	5.46
21.5	5.7	12.0	6.3	15.3	0.0141	1.00	60	0.0071	5.05
22.0	5.6	10.5	4.9	15.6	0.0140	1.00	250	0.0035	3.97
22.0	5.6	9.0	3.4	15.8	0.0140	1.00	1440	0.0015	2.77

SPECIFIC GRAVITY	BOTTLE #	Bottle Wt	Bott & Water	WaterTemp	Corr. Soil	Bott, S & Water	WaterTemp	Specif. Grav	
Air dry Sample(gr)	25	4	179.25	677.26	22.5	24.91	692.79	22.5	2.655

Sieve % Pass	Sieve Size	Grams Retain	% Pass
Air Dry Start Wt.:	1-1/2"	0.00	100.00
243.3	1"	0.00	100.00
Dry Start Wt.:	3/4"	0.00	100.00
242.38	3/8"	13.45	94.47
	No 4	77.42	68.18
	No 10	145.71	40.11

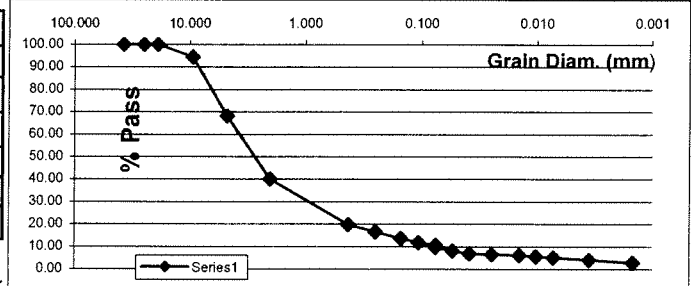

Remarks:

HYDROMETER AND MECHANICAL ANALYSIS OF SOIL BINDER, ASTM D422

PROJECT: Luminant Martin Lake, PDP 1-3
CLIENT: TXU
CONTRACTOR: not given
JOB No. : G 2810 - 08

REPORT No.:
DATE SAMPLED: February 2008
SAMPLED BY: E TTL Drill Crew
LOCATION: B-6, 18'-20'
SAMPLE No. :
DESCRIPTION: Tan Ash
TECHNICIAN: H. Walka
DATE: 03/14/08

RESULTS

Grain Diameter	% Retain	% Passing
+2.0 mm	10.97	
+0.05 mm	18.74	
0.05 to 2.0 mm		7.77
0.002 to 0.05 mm		77.39
> 0.002 mm		3.87

WEIGHT OF SAMPLE (AIR DRY)	50.00
WEIGHT OF SAMPLE (OVEN DRY)	49.81
PERCENT RETAINED ON # 10	10.97
SPECIFIC GRAVITY	2.732

	SIEVE	WEIGHT	%RETAIN	GRAIN DIA	%PASSING
Mc Hydrom	40	0.26	11.44	0.425	88.56
Tare Wt	29.86	60	0.42	0.250	88.28
Wet Wt.	51.33	100	0.78	0.150	87.64
Dry Wt	51.25	140	1.61	0.105	86.15
MC	0.3740%	200	2.62	0.075	84.35

TEMP (C)	HYDROMETER CORRECTION	HYDROMETER READING	CORRECTED READING	L.Hydrom FACTOR	K. Diam. FACTOR	a. SP.GR. FACTOR	TIME (MIN)	GRAIN DIA (MM)	% SOIL PASSING
22.0	5.6	52.0	46.4	8.8	0.0140	0.99	0.5	0.0586	82.16
22.0	5.6	51.0	45.4	8.9	0.0140	0.99	1	0.0417	80.39
22.0	5.6	48.5	42.9	9.4	0.0140	0.99	2	0.0303	75.97
22.0	5.6	47.0	41.4	9.6	0.0140	0.99	5	0.0194	73.31
22.0	5.6	35.0	29.4	11.5	0.0140	0.99	15	0.0122	52.08
22.0	5.6	13.0	7.4	15.2	0.0140	0.99	30	0.0099	13.15
22.0	5.6	9.5	3.9	15.8	0.0140	0.99	60	0.0072	6.96
22.0	5.6	8.5	2.9	16	0.0140	0.99	250	0.0035	5.19
22.0	5.6	7.5	1.9	16.1	0.0140	0.99	1440	0.0015	3.42

SPECIFIC GRAVITY	BOTTLE #	Bottle Wt	Bott & Water	WaterTemp	Corr. Soil	Bott, S & Water	WaterTemp	Specif. Grav	
Air dry Sample(gr)	50	3	179.93	678.11	22.5	49.81	709.70	22.5	2.732

Sieve % Pass	Sieve Size	Grams Retain	% Pass
Air Dry Start Wt.:	1-1/2"	0.00	100.00
262.8	1"	28.83	89.03
Dry Start Wt.:	3/4"	28.83	89.03
261.82	3/8"	28.83	89.03
	No 4	28.83	89.03
	No 10	28.83	89.03

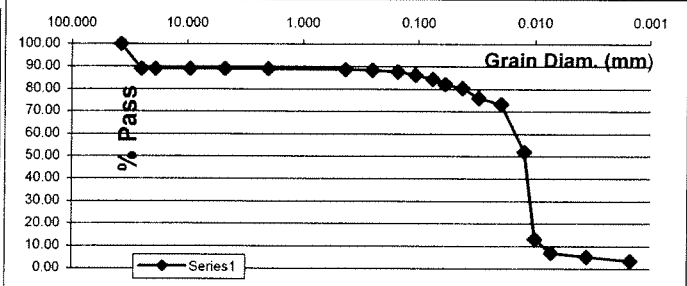

Remarks:

HYDROMETER AND MECHANICAL ANALYSIS OF SOIL BINDER, ASTM D422

PROJECT: Luminant Martin Lake, PDP 1-3
CLIENT: TXU
CONTRACTOR: not given
JOB No. : G 2810 - 08

REPORT No.:

DATE SAMPLED: February 2008
SAMPLED BY: E TTL Drill Crew
LOCATION: B-3, 5'-7'
SAMPLE No. :
DESCRIPTION: Black Ash
TECHNICIAN: H. Walka
DATE: 03/06/08

RESULTS

Grain Diameter	
% Retain	+2.0 mm 11.60
% Retain	+0.05 mm 76.50
% Passing	0.05 to 2.0 mm 64.91
% Passing	0.002 to 0.05 mm 21.88
% Passing	> 0.002 mm 1.62

WEIGHT OF SAMPLE (AIR DRY)	50.00
WEIGHT OF SAMPLE (OVEN DRY)	49.53
PERCENT RETAINED ON # 10	11.60
SPECIFIC GRAVITY	2.561

	SIEVE	WEIGHT	%RETAIN	GRAIN DIA	%PASSING
Mc Hydrom	40	7.81	25.54	0.425	74.46
Tare Wt	29.43	60	11.21	0.250	68.39
Wet Wt.	65.41	100	17.82	0.150	56.59
Dry Wt	65.07	140	22.64	0.105	47.99
MC	0.9540%	200	26.25	0.075	41.55

TEMP (C)	HYDROMETER CORRECTION	HYDROMETER READING	CORRECTED READING	L.Hydrom FACTOR	K. Diam. FACTOR	a. SP.GR. FACTOR	TIME (MIN)	GRAIN DIA (MM)	% SOIL PASSING
20.0	6.2	24.5	18.3	13.3	0.0143	1.02	0.5	0.0738	33.31
20.0	6.2	20.0	13.8	14.2	0.0143	1.02	1	0.0539	25.11
20.0	6.2	16.5	10.3	14.7	0.0143	1.02	2	0.0388	18.74
20.0	6.2	14.5	8.3	15	0.0143	1.02	5	0.0248	15.10
20.0	6.2	12.0	5.8	15.5	0.0143	1.02	15	0.0145	10.55
19.5	6.4	11.0	4.6	15.6	0.0145	1.02	30	0.0104	8.44
19.5	6.4	10.0	3.6	15.8	0.0145	1.02	60	0.0074	6.62
20.0	6.2	8.0	1.8	16.1	0.0143	1.02	250	0.0036	3.27
19.5	6.4	7.0	0.6	16.3	0.0145	1.02	1440	0.0015	1.15

SPECIFIC GRAVITY	BOTTLE #	Bottle Wt	Bott & Water	WaterTemp	Corr. Soil	Bott, S & Water	WaterTemp	Specif. Grav	
Air dry Sample(gr)	100	7	179.97	678.12	22.5	99.06	738.67	21.0	2.561

	Sieve Size	Grams Retain	% Pass
Sieve % Pass	1-1/2"	0.00	100.00
Air Dry Start Wt.:	1"	0.00	100.00
335.3	3/4"	0.00	100.00
Dry Start Wt.:	3/8"	3.42	98.98
332.13	No 4	17.17	94.88
	No 10	38.89	88.40

Remarks:

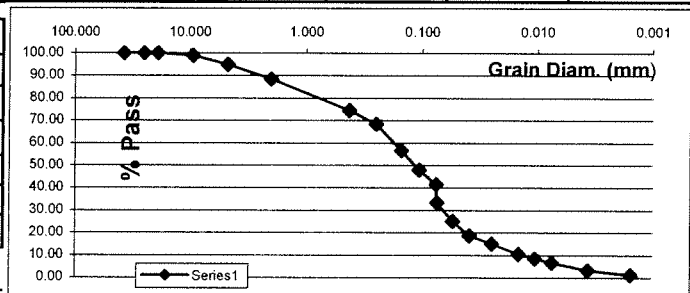

HYDROMETER AND MECHANICAL ANALYSIS OF SOIL BINDER, ASTM D422

PROJECT: Luminant Martin Lake, PDP 1-3
 CLIENT: TXU
 CONTRACTOR: not given
 JOB No. : G 2810 - 08

REPORT No.:

DATE SAMPLED: February 2008
 SAMPLED BY: E TTL Drill Crew
 LOCATION: B-2, 23'-25'
 SAMPLE No. :
 DESCRIPTION: Light Gray & Black Ash
 TECHNICIAN: H. Walka
 DATE: 03/06/08

RESULTS

		Grain Diameter
% Retain	+2.0 mm	0.76
% Retain	+0.05 mm	16.00
% Passing	0.05 to 2.0 mm	15.24
% Passing	0.002 to 0.05 mm	83.90
% Passing	> 0.002 mm	0.09

WEIGHT OF SAMPLE (AIR DRY)	50.00
WEIGHT OF SAMPLE (OVEN DRY)	49.16
PERCENT RETAINED ON # 10	0.76
SPECIFIC GRAVITY	2.675

	SIEVE	WEIGHT	%RETAIN	GRAIN DIA	%PASSING
Mc Hydrom	40	0.89	2.56	0.425	97.44
Tare Wt	29.91	60	1.22	0.250	96.78
Wet Wt.	55.02	100	2.01	0.150	95.18
Dry Wt	54.60	140	2.67	0.105	93.85
MC	1.7011%	200	3.07	0.075	93.04

TEMP (C)	HYDROMETER CORRECTION	HYDROMETER READING	CORRECTED READING	L.Hydrom FACTOR	K. Diam. FACTOR	a. SP.GR. FACTOR	TIME (MIN)	GRAIN DIA (MM)	% SOIL PASSING
20.0	6.2	48.5	42.3	9.4	0.0143	1.00	0.5	0.0620	85.37
20.0	6.2	47.5	41.3	9.6	0.0143	1.00	1	0.0443	83.35
20.0	6.2	46.5	40.3	9.7	0.0143	1.00	2	0.0315	81.33
20.0	6.2	44.5	38.3	10.1	0.0143	1.00	5	0.0203	77.30
20.0	6.2	35.0	28.8	11.7	0.0143	1.00	15	0.0126	58.12
20.0	6.2	19.0	12.8	14.3	0.0143	1.00	30	0.0099	25.83
20.0	6.2	6.5	0.3	16.3	0.0143	1.00	60	0.0075	0.59
20.0	6.2	6.3	0.1	16.3	0.0143	1.00	250	0.0037	0.19
19.5	6.4	6.4	0.0	16.3	0.0145	1.00	1440	0.0015	0.07

SPECIFIC GRAVITY	BOTTLE #	Bottle Wt	Bott & Water	WaterTemp	Corr. Soil	Bott, S & Water	WaterTemp	Specif. Grav	
Air dry Sample(gr)	50	4	179.25	677.26	22.5	49.16	708.22	21.0	2.675

Sieve % Pass	Sieve Size	Grams Retain	% Pass
Air Dry Start Wt.:	1-1/2"	0.00	100.00
144.3	1"	0.00	100.00
Dry Start Wt.:	3/4"	0.00	100.00
141.89	3/8"	0.00	100.00
	No 4	0.10	99.93
	No 10	1.10	99.24

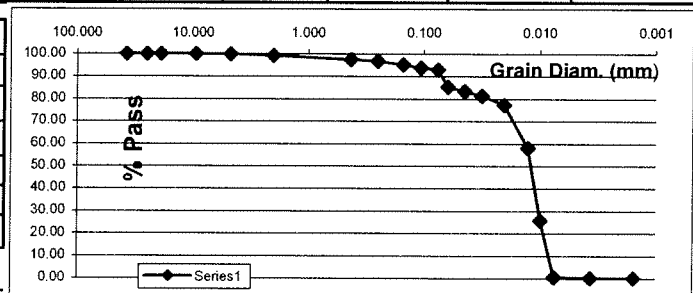

Remarks:

HYDROMETER AND MECHANICAL ANALYSIS OF SOIL BINDER, ASTM D422

PROJECT: Luminant Martin Lake, PDP 1-3
CLIENT: TXU
CONTRACTOR: not given
JOB No. : G 2810 - 08

REPORT No.:

DATE SAMPLED: February 2008
SAMPLED BY: E TTL Drill Crew
LOCATION: B-1, 18'-20'
SAMPLE No. :
DESCRIPTION: Black, Tan & Gray Ash
TECHNICIAN: H. Walka
DATE: 03/06/08

RESULTS

Grain Diameter		
% Retain	+2.0 mm	14.96
% Retain	+0.05 mm	64.42
% Passing	0.05 to 2.0 mm	49.46
% Passing	0.002 to 0.05 mm	35.29
% Passing	> 0.002 mm	0.29

WEIGHT OF SAMPLE (AIR DRY)	50.00
WEIGHT OF SAMPLE (OVEN DRY)	49.29
PERCENT RETAINED ON # 10	14.96
SPECIFIC GRAVITY	2.608

	SIEVE	WEIGHT	%RETAIN	GRAIN DIA	%PASSING
Mc Hydrom	40	5.76	24.90	0.425	75.10
Tare Wt	29.29	60	8.38	0.250	70.58
Wet Wt.	59.40	100	12.31	0.150	63.80
Dry Wt	58.97	140	15.78	0.105	57.81
MC	1.4488%	200	18.60	0.075	52.95

TEMP (C)	HYDROMETER CORRECTION	HYDROMETER READING	CORRECTED READING	L.Hydrom FACTOR	K. Diam. FACTOR	a. SP.GR. FACTOR	TIME (MIN)	GRAIN DIA (MM)	% SOIL PASSING
20.0	6.2	31.5	25.3	12.2	0.0143	1.01	0.5	0.0707	44.08
20.0	6.2	27.0	20.8	13	0.0143	1.01	1	0.0516	36.24
20.0	6.2	24.5	18.3	13.3	0.0143	1.01	2	0.0369	31.88
20.0	6.2	23.5	17.3	13.5	0.0143	1.01	5	0.0235	30.14
20.0	6.2	18.5	12.3	14.3	0.0143	1.01	15	0.0140	21.43
20.0	6.2	10.0	3.8	15.8	0.0143	1.01	30	0.0104	6.61
20.0	6.2	7.0	0.8	16.3	0.0143	1.01	60	0.0075	1.38
20.0	6.2	6.5	0.3	16.3	0.0143	1.01	250	0.0037	0.51
19.5	6.4	6.5	0.1	16.3	0.0145	1.01	1440	0.0015	0.23

SPECIFIC GRAVITY	BOTTLE #	Bottle Wt	Bott & Water	WaterTemp	Corr. Soil	Bott, S & Water	WaterTemp	Specif. Grav	
Air dry Sample(gr)	100	3	179.93	678.11	22.5	98.57	739.11	20.5	2.608

Sieve Size	Grams Retain	% Pass
Sieve % Pass	1-1/2"	0.00
Air Dry Start Wt.:	1"	0.00
268.4	3/4"	15.10
Dry Start Wt.:	3/8"	15.10
264.57	No 4	25.58
	No 10	40.15

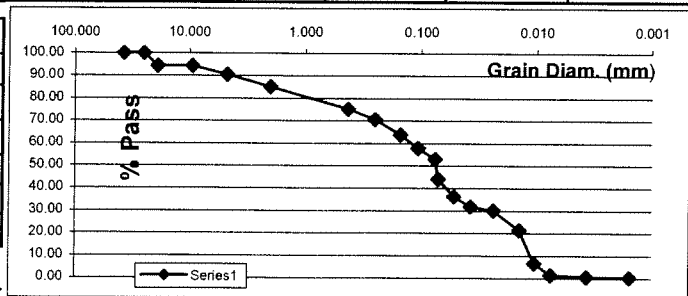

Remarks:

HYDROMETER AND MECHANICAL ANALYSIS OF SOIL BINDER, ASTM D422

PROJECT: Luminant Martin Lake, PDP 1-3
CLIENT: TXU
CONTRACTOR: not given
JOB No. : G 2810 - 08

REPORT No.:
DATE SAMPLED: February 2008
SAMPLED BY: E TTL Drill Crew
LOCATION: MLSES
SAMPLE No. :
DESCRIPTION: Tan & Gray Economizet Ash
TECHNICIAN: M. Thompson
DATE: 04/15/08

RESULTS

Grain Diameter	% Retain	% Passing
+2.0 mm	41.02	
+0.05 mm	95.89	
0.05 to 2.0 mm		54.87
0.002 to 0.05 mm		3.55
> 0.002 mm		0.55

WEIGHT OF SAMPLE (AIR DRY)	50.00
WEIGHT OF SAMPLE (OVEN DRY)	49.98
PERCENT RETAINED ON # 10	41.02
SPECIFIC GRAVITY	2.670

	SIEVE	WEIGHT	%RETAIN	GRAIN DIA	%PASSING
Mc Hydrom	40	13.34	56.76	0.425	43.24
Tare Wt	30.27	60	22.12	0.250	32.88
Wet Wt.	62.43	100	32.26	0.150	20.91
Dry Wt	62.42	140	38.01	0.105	14.13
MC	0.0311%	200	42.66	0.075	8.64

TEMP (C)	HYDROMETER CORRECTION	HYDROMETER READING	CORRECTED READING	L.Hydrom FACTOR	K. Diam. FACTOR	a. SP.GR. FACTOR	TIME (MIN)	GRAIN DIA (MM)	% SOIL PASSING
21.5	5.7	13.0	7.3	15.2	0.0141	1.00	0.5	0.0780	8.58
21.5	5.7	10.0	4.3	15.6	0.0141	1.00	1	0.0558	5.04
21.5	5.7	9.0	3.3	15.8	0.0141	1.00	2	0.0397	3.86
21.5	5.7	7.5	1.8	16.1	0.0141	1.00	5	0.0254	2.09
21.5	5.7	7.0	1.3	16.1	0.0141	1.00	15	0.0146	1.50
21.5	5.7	6.8	1.1	16.1	0.0141	1.00	30	0.0104	1.27
21.5	5.7	6.5	0.8	16.3	0.0141	1.00	60	0.0074	0.91
21.5	5.7	6.3	0.6	16.3	0.0141	1.00	250	0.0036	0.68
22.0	5.6	6.0	0.4	16.3	0.0140	1.00	1440	0.0015	0.51

SPECIFIC GRAVITY	BOTTLE #	Bottle Wt	Bott & Water	WaterTemp	Corr. Soil	Bott, S & Water	WaterTemp	Specif. Grav	
Air dry Sample(gr)	100	7	179.97	678.12	22.5	99.97	740.78	21.5	2.670

Sieve % Pass	Sieve Size	Grams Retain	% Pass
Air Dry Start Wt.:	1-1/2"	0.00	100.00
2182.9	1"	0.00	100.00
Dry Start Wt.:	3/4"	0.00	100.00
2182.22	3/8"	12.53	99.43
	No 4	200.01	90.83
	No 10	895.12	58.98

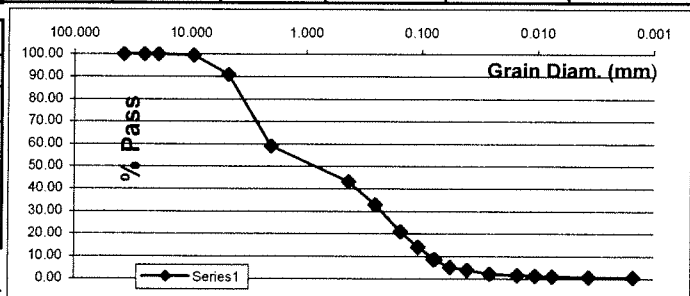

Remarks:

ASTM D 2850 Confined Compressive Strength of Cohesive Soil

Project: Luminant Martin Lake: PDP 1-3

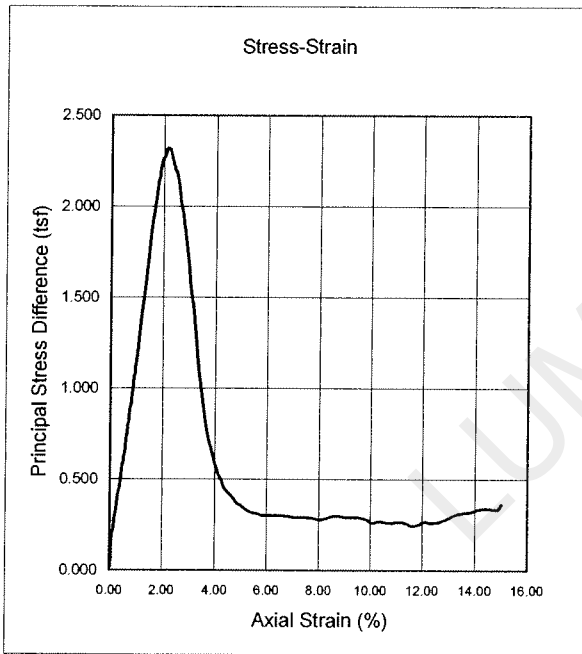

Project No.:	<u>G 2810-08</u>	
Boring No.:	<u>B-7</u>	
Depth, ft.:	<u>5'-7'</u>	
Material:	<u>Black Ash with Gravel</u>	
Initial Height	<u>5.706</u>	<u>Inches</u>
Initial Diameter	<u>2.767</u>	<u>Inches</u>
Moisture Content:	<u>22.9%</u>	<u>%</u>
Dry Density:	<u>97.5</u>	<u>lbs/cu ft</u>
Specific Gravity (Assumed)	<u>2.670</u>	
Volume of Solids:	<u>0.585</u>	
Volume of Voids	<u>0.415</u>	
Void Ratio:	<u>0.709</u>	
Confining Pressure:	<u>6.1</u>	<u>PSI</u>
Pocket Penetr. Reading:	<u>4.5</u>	
Torvane (T)	<u> </u>	
Rate of Strain: (%/ min)	<u>1.0%</u>	
Peak Strain:	<u>2.1</u>	<u>%</u>
Max Stress:	<u>2.32</u>	<u>TSF</u>
Date:	<u>3/11/2008</u>	

1/2 Stress (KSF) 2.321

Strain at 1/2 Stress (%) 0.99

Type of Specimen: Native

Remarks: _____

Secant Modulus (KSF) @ 1/2 Peak Stress 234

RQD Value: 100%

Angle of Fracture in Degrees: 65

Sketch of Fracture:



ASTM D 2850 Confined Compressive Strength of Cohesive Soil

Project: TXU PDP: Martin Lake, TX

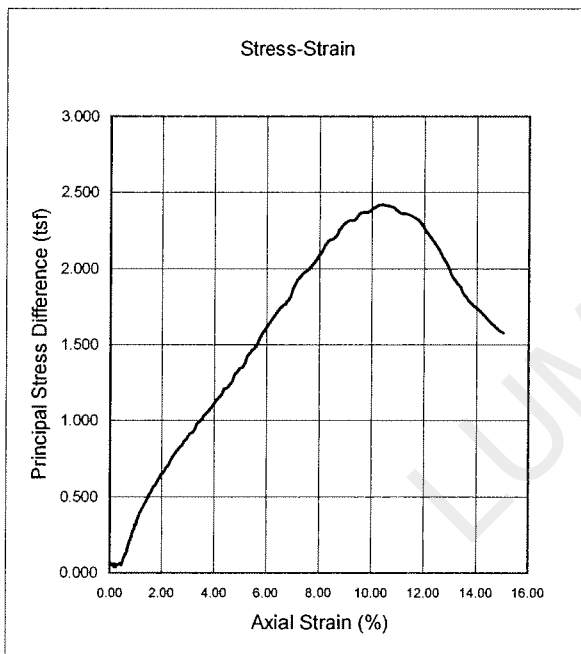

Project No.:	<u>G 2810-08</u>
Boring No.:	<u>B-4</u>
Depth, ft.:	<u>13'-15'</u>
Material:	<u>Red & Gray Laminated Lean Clay</u>
Initial Height	<u>3.613</u> Inches
Initial Diameter	<u>2.667</u> Inches
Moisture Content:	<u>22.3%</u> %
Dry Density:	<u>99.4</u> lbs/cu ft
Specific Gravity (Assumed)	<u>2.670</u>
Volume of Solids:	<u>0.596</u>
Volume of Voids	<u>0.404</u>
Void Ratio:	<u>0.677</u>
Confining Pressure:	<u>13</u> PSI
Pocket Penetr. Reading:	<u>3.5</u>
Torvane (T)	<u></u>
Rate of Strain: (%/ min)	<u>1.0%</u>
Peak Strain:	<u>10.3</u> %
Max Stress:	<u>2.42</u> TSF
Date:	<u>5/12/2008</u>

1/2 Stress (KSF) 2.416

Strain at 1/2 Stress (%) 3.94

Type of Specimen: Native

Remarks: undefined fracture

Secant Modulus (KSF) @ 1/2 Peak Stress 61

RQD Value: 100%

Angle of Fracture in Degrees: N/A

Sketch of Fracture:

ASTM D 2850 Confined Compressive Strength of Cohesive Soil

Project: Luminant Martin Lake: PDP 1-3

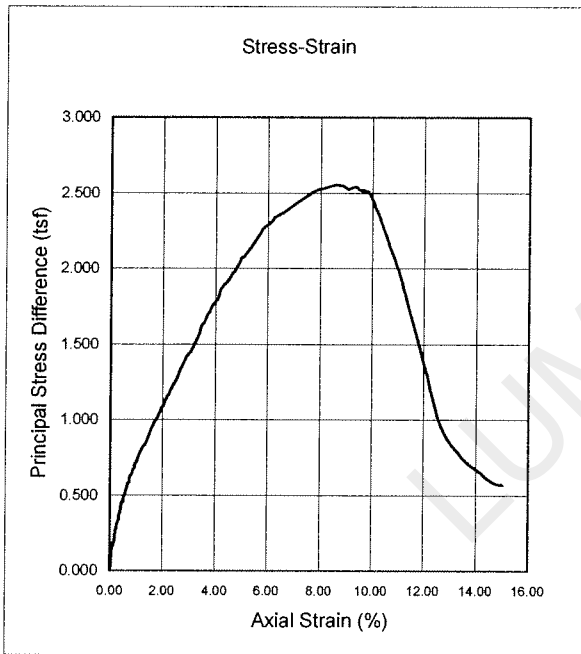

Project No.: G 2810-08
 Boring No.: B-4
 Depth, ft.: 13'-15'
 Material: Light Gray & Red Silty Clayey Sand w/ Ferric seams
 Initial Height 5.688 Inches
 Initial Diameter 2.75 Inches
Moisture Content: 21.5% %
 Dry Density: 104.6 lbs/cu ft
 Specific Gravity (Assumed) 2.670
 Volume of Solids: 0.628
 Volume of Voids 0.372
 Void Ratio: 0.593
 Confining Pressure: 13 PSI
 Pocket Penetr. Reading: 3.9
 Torvane (T) 1.138
 Rate of Strain: (%/ min) 1.0%
Peak Strain: 8.6 %
Max Stress: 2.55 TSF
 Date: 4/11/2008

1/2 Stress (KSF) 2.552

Strain at 1/2 Stress (%) 2.54

Type of Specimen: Native

Remarks: _____

Secant Modulus (KSF) @ 1/2 Peak Stress 100

RQD Value: 100%

Angle of Break in Degrees: 60

Sketch of Fracture:



ASTM D 2850 Confined Compressive Strength of Cohesive Soil

Project: Luminant Martin Lake: PDP 1-3

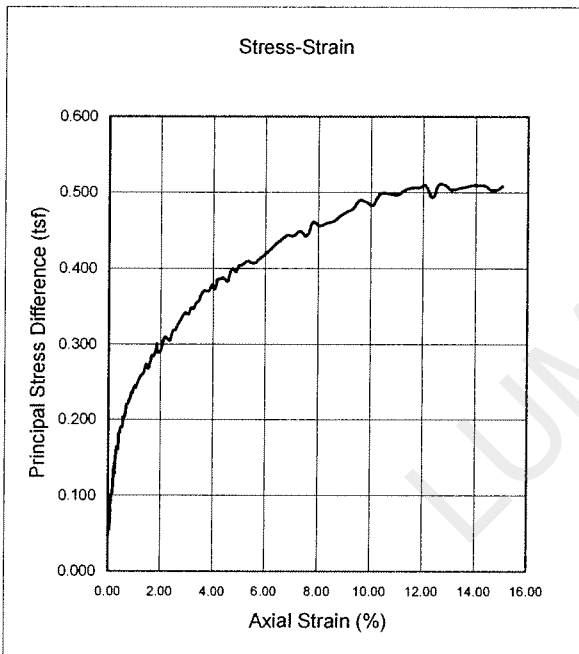

Project No.:	<u>G 2810-08</u>
Boring No.:	<u>B-7</u>
Depth, ft.:	<u>23'-25'</u>
Material:	<u>Black, Red, Tan, & Gray Clay w/ gravel</u>
Initial Height	<u>5.686</u> Inches
Initial Diameter	<u>2.717</u> Inches
Moisture Content:	<u>21.0%</u> %
Dry Density:	<u>103.9</u> lbs/cu ft
Specific Gravity (Assumed)	<u>2.670</u>
Volume of Solids:	<u>0.624</u>
Volume of Voids	<u>0.376</u>
Void Ratio:	<u>0.603</u>
Confining Pressure:	<u>21.7</u> PSI
Pocket Penetr. Reading:	<u> </u>
Torvane (T)	<u> </u>
Rate of Strain: (%/ min)	<u>1.0%</u>
Peak Strain:	<u>12.8</u> %
Max Stress:	<u>0.51</u> TSF
Date:	<u>3/11/2008</u>

1/2 Stress (KSF) 0.510

Strain at 1/2 Stress (%) 1.20

Type of Specimen: Native

Remarks: Not able to find a well defined fracture

Secant Modulus (KSF) @ 1/2 Peak Stress 43

RQD Value: 100%

Angle of Break in Degrees: 53

Sketch of Fracture:

CONSOLIDATION TEST REPORT

ASTM D 2435

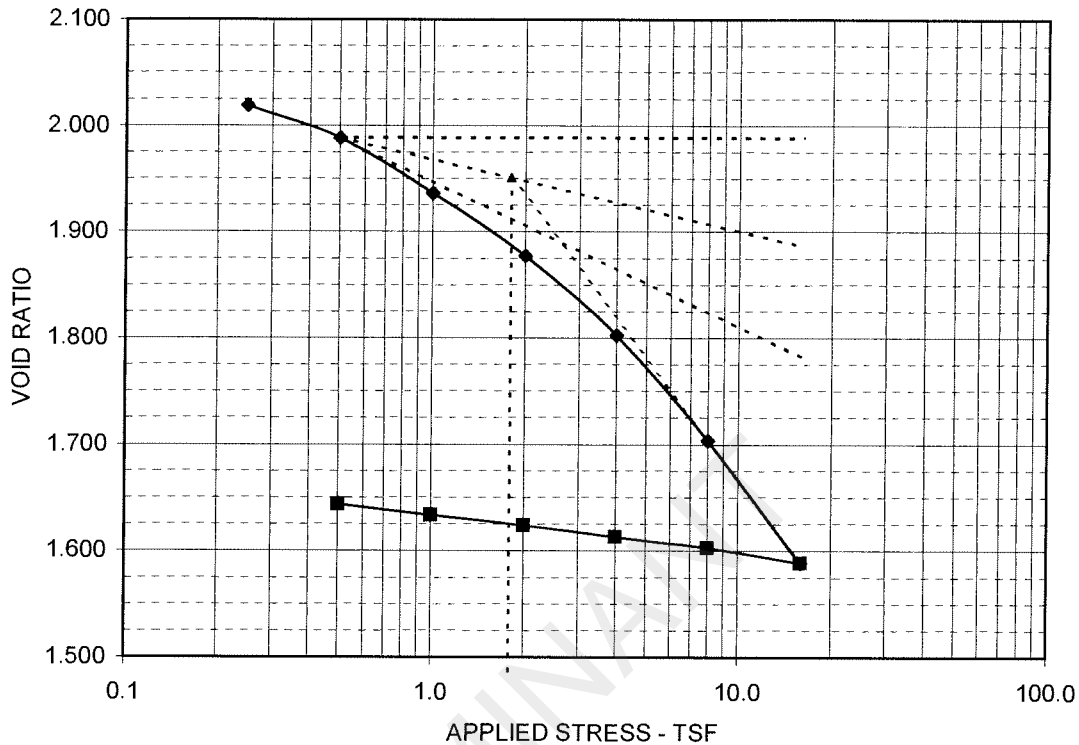

$C_c = 0.381$ $C_r = 0.033$ $e_0 = 2.0191$ P_c (tsf) = 1.79 OCR = 10.2

LOAD tsf	c_v in ² /min	k in/min
Seating	NA	NA
0.50	9.34E-03	9.85E-07
1.00	5.36E-03	4.89E-07
2.00	5.03E-03	2.65E-07
4.00	5.04E-03	1.73E-07
8.00	5.03E-03	1.18E-07
16.00	5.03E-03	7.08E-08

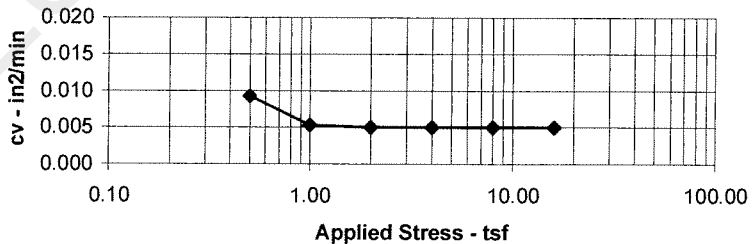

c_v values calculated by Sivaram and Swamee's Method

SAMPLE AND TEST DATA	PROJECT INFORMATION
SAMPLE LOCATION: B-6, 3-5' DESCRIPTION: Ash, black and dark gray LL: NA PL: NA PI: NA -200:NA ASSUMED SPECIFIC GRAVITY: 2.70 MC Initial: 58.1% MC Final: 47.2% Dia. (in.): 2.50 Height (in.): 1.000 Initial Sat %: 70.2 Final Sat %: 100.0 DRY DENSITY (pcf): 55.8	PROJECT: Luminant Martin Lake PDP 1-3 LOCATION: Rusk, TX. PROJECT NO.: ETT08002-07 CLIENT: E TTL Engineers & Consultants, Inc. CLIENT NO.: G2810-08 DATE: 4/24/2008 REMARKS: OCR calculated based on P_c and vertical overburden
GREGORY GEOTECHNICAL	
PLATE B-CN.1	

CONSOLIDATION TEST REPORT

ASTM D 2435

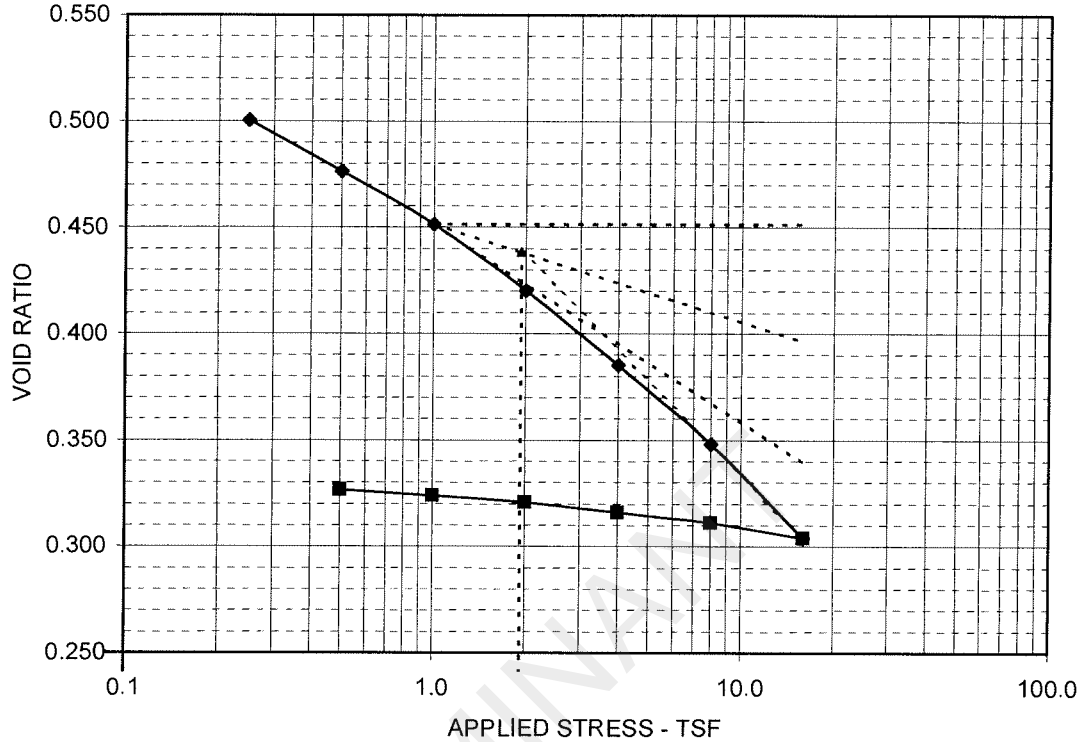

$C_c = 0.146$ $C_r = 0.012$ $e_0 = 0.5597$ P_c (tsf) = 1.93 OCR = 3.5

LOAD tsf	c_v in ² /min	k in/min
Seating	NA	NA
0.50	1.67E-02	2.82E-06
1.00	1.51E-02	1.33E-06
2.00	1.55E-02	8.75E-07
4.00	1.54E-02	5.00E-07
8.00	1.51E-02	2.67E-07
16.00	1.39E-02	1.50E-07

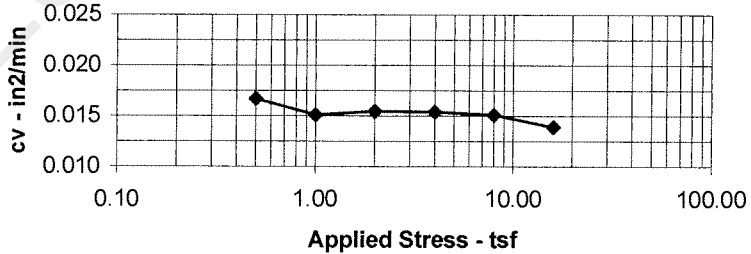

c_v values calculated by Sivaram and Swamee's Method

SAMPLE AND TEST DATA	PROJECT INFORMATION
SAMPLE LOCATION: B-4, 8-10' DESCRIPTION: Clayey Sand , reddish brown with gray LL: NA PL: NA PI: NA -200: NA ASSUMED SPECIFIC GRAVITY: 2.70 MC Initial: 13.0% MC Final: 19.6% Dia. (in.): 2.50 Height (in.): 1.000 Initial Sat %: 70.2 Final Sat %: 100.0 DRY DENSITY (pcf): 108.0	PROJECT: Luminant Martin Lake PDP 1-3 LOCATION: Rusk, TX. PROJECT NO.: ETT08002-07 CLIENT: E TTL Engineers & Consultants, Inc. CLIENT NO.: G2810-08 DATE: 4/24/2008 REMARKS: OCR calculated based on Pc and vertical overburden
GREGORY GEOTECHNICAL	PLATE B-CN.2

$y = 0.8336x + 0.45$
 $R^2 = 0.9982$

DIRECT SHEAR TEST REPORT

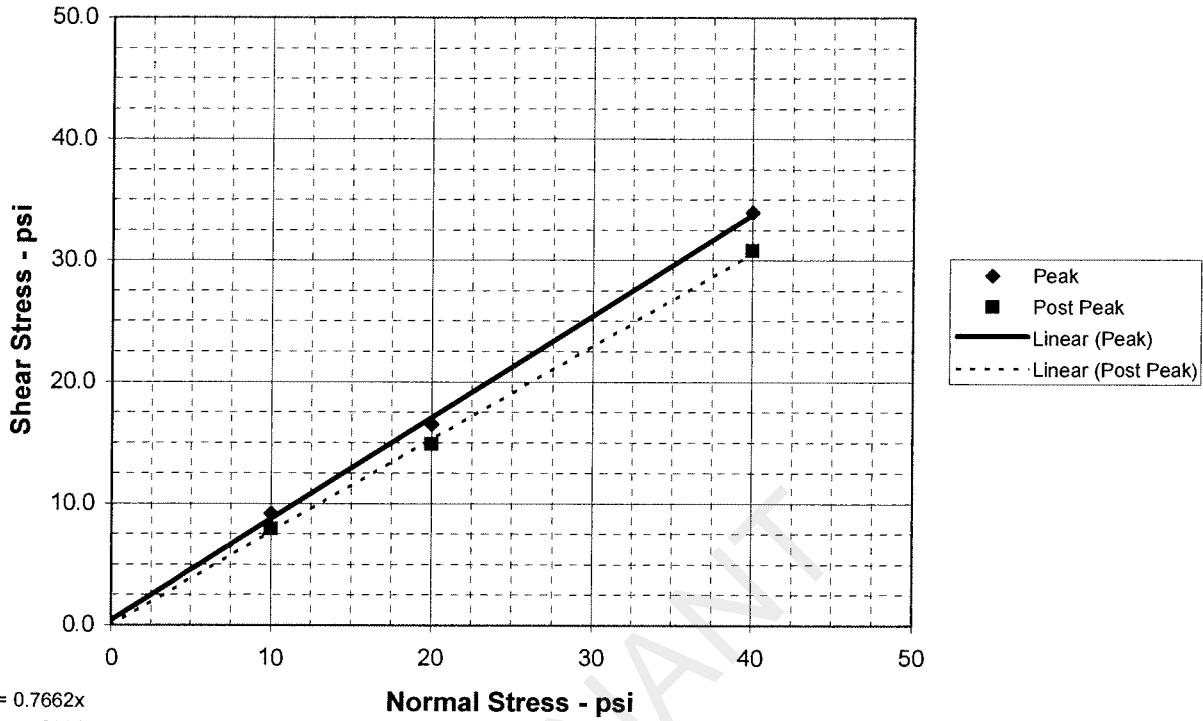

$y = 0.7662x$
 $R^2 = 0.9991$

PEAK STRENGTH PARAMETERS	$\phi = 39.8 \text{ deg}$	$c = 0.5 \text{ psi}$
POST PEAK STRENGTH PARAMETERS	$\phi = 37.5 \text{ deg}$	$c = 0.0 \text{ psi}$

	SPECIMEN NO.	1	2	3	4	
	INITIAL					
	Moisture Content - %	52.1	29.3	21.2		
	Dry Density - pcf	50.2	71.7	95.2		
	Diameter - inches	2.50	2.50	2.50		
	Height - inches	1.13	1.13	1.13		
	AT TEST					
	Final Moisture - %	64.3	25.0	31.6		
	Dry Density - pcf	55.8	79.1	117.3		
	Height-End of Consol. (in.)	1.02	1.03	0.92		
Height-End of Shear (in.)	0.97	0.99	0.89			
Normal Stress - psi	10.0	20.0	40.0			
Peak Failure Stress-psi	9.2	16.5	34.0			
Post Peak Failure Stress-psi	7.9	14.9	30.8			
Strain Rate - inches/min.	0.00300	0.00300	0.00300			
Peak Failure Strain - %	16.2	15.6	15.6			
Post Peak Failure Strain %	8.4	7.2	9.6			
Dry Density at test based on initial moisture and height at end of consolidation.						

TEST DESCRIPTION	PROJECT INFORMATION
TYPE OF TEST & NO: CD-DS-1 SAMPLE TYPE: Shelby Tube DESCRIPTION: Ash, black and gray SAMPLE LOCATION: B-6, 3-5 ft ASSUMED SPECIFIC GRAVITY: 2.65 LL: 35 PL: 19 PI: 16 Percent -200: 61 REMARKS: Multi-Specimen	PROJECT: Luminant Martin Lake PDP 1-3 LOCATION: Rusk, TX PROJECT NO: ETT08002-07 (G2810-08) CLIENT: E TTL Engineers & Consultants, Inc DATE: 4/25/08 <hr/> <div style="display: flex; justify-content: space-between;"> GREGORY GEOTECHNICAL PLATE: B-DS.1 </div>

$y = 0.8829x + 2.2$
 $R^2 = 0.9987$

DIRECT SHEAR TEST REPORT

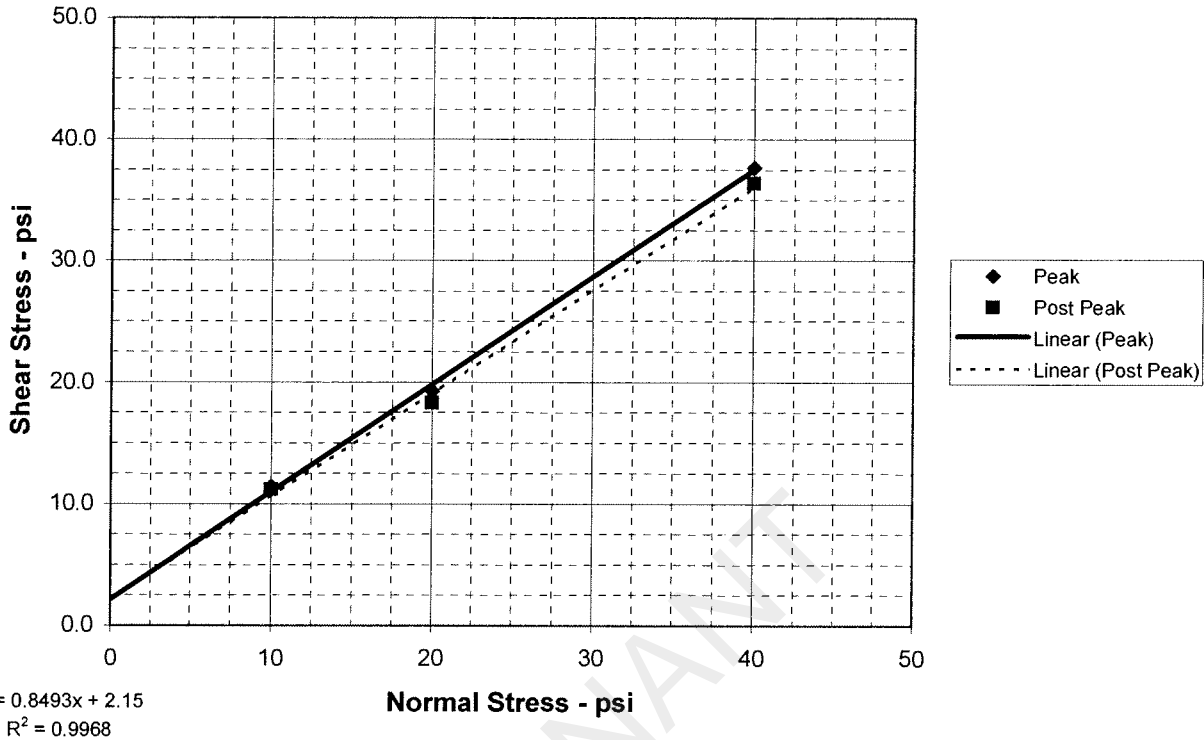

PEAK STRENGTH PARAMETERS	$\phi = 41.4$ deg	$c = 2.2$ psi
POST PEAK STRENGTH PARAMETERS	$\phi = 40.3$ deg	$c = 2.2$ psi

	SPECIMEN NO.	1	2	3	4	
	INITIAL					
	Moisture Content - %	13.1	13.1	13.1		
	Dry Density - pcf	71.8	71.7	71.7		
	Diameter - inches	2.50	2.50	2.50		
	Height - inches	1.00	1.00	1.00		
	AT TEST					
	Final Moisture - %	38.5	37.4	31.6		
	Dry Density - pcf	73.6	73.7	75.8		
	Height-End of Consol. (in.)	0.98	0.97	0.95		
Height-End of Shear (in.)	1.00	0.96	0.92			
Normal Stress - psi	10.0	20.0	40.0			
Peak Failure Stress-psi	11.4	19.3	37.7			
Post Peak Failure Stress-psi	11.2	18.3	36.4			
Strain Rate - inches/min.	0.00300	0.00300	0.00300			
Peak Failure Strain - %	15.6	15.6	13.2			
Post Peak Failure Strain %	13.8	12.0	15.0			
Dry Density at test based on initial moisture and height at end of consolidation.						

TEST DESCRIPTION	PROJECT INFORMATION
TYPE OF TEST & NO: CD-DS-2 SAMPLE TYPE: Re-Compacted DESCRIPTION: Ash, black and dark gray SAMPLE LOCATION: MLSES (Bulk) SPECIFIC GRAVITY: 2.56 LL: NP PL: NP PI: NP Percent -200: 3.33 REMARKS: Multi-Specimen	PROJECT: Luminant Martin Lake PDP 1-3 LOCATION: Rusk , TX PROJECT NO: ETT08002-07 (G2810-08) CLIENT : ETTL Engineers & Consultants, Inc DATE:5/6/08 <div style="display: flex; justify-content: space-between; margin-top: 10px;"> GREGORY GEOTECHNICAL PLATE: B-DS.2 </div>

$y = 0.9043x + 5.7$
 $R^2 = 0.9961$

DIRECT SHEAR TEST REPORT

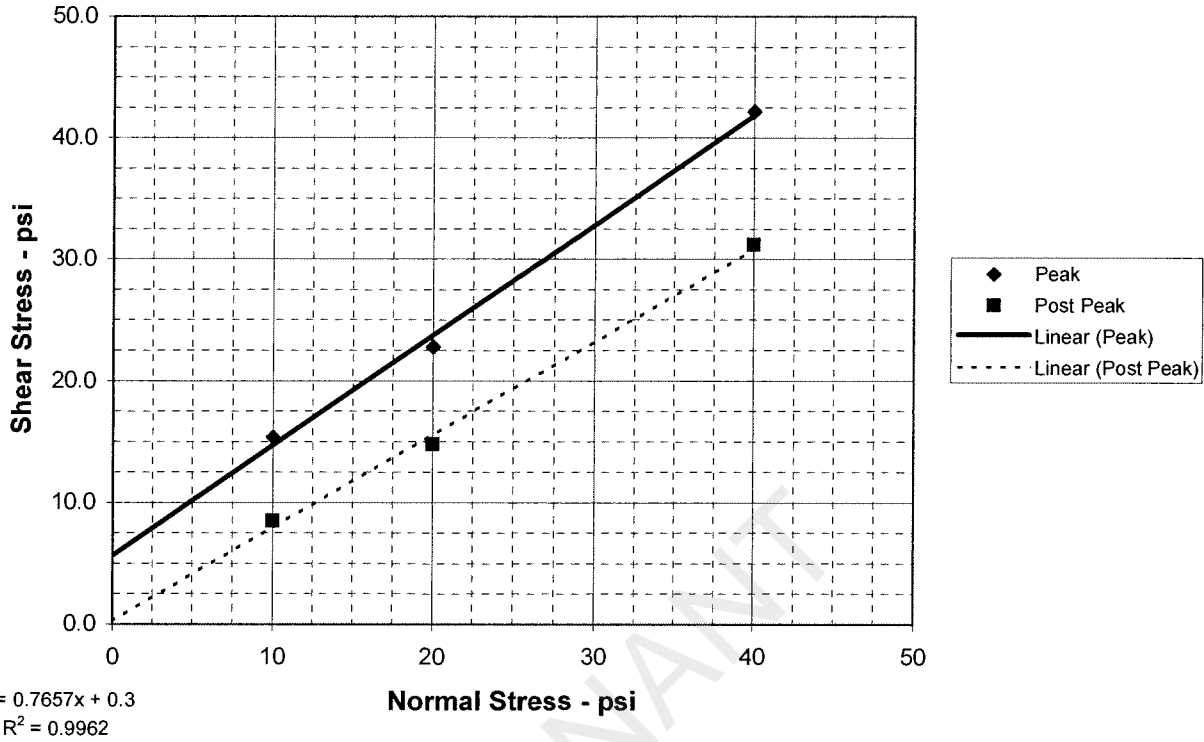

PEAK STRENGTH PARAMETERS	$\phi = 42.1 \text{ deg}$	$c = 5.7 \text{ psi}$
POST PEAK STRENGTH PARAMETERS	$\phi = 37.4 \text{ deg}$	$c = 0.3 \text{ psi}$

	SPECIMEN NO.	1	2	3	4	
	INITIAL					
	Moisture Content - %	0.1	0.1	0.1	0.1	0.1
	Dry Density - pcf	71.7	71.7	71.7	71.7	71.7
	Diameter - inches	2.50	2.50	2.50	2.50	2.50
	Height - inches	1.00	1.00	1.00	1.00	1.00
	AT TEST					
	Final Moisture - %	50.3	37.4	31.6	31.6	31.6
	Dry Density - pcf	73.4	73.1	73.1	73.1	73.1
	Height-End of Consol. (in.)	0.98	0.98	0.98	0.98	0.98
Height-End of Shear (in.)	1.01	1.01	0.99	0.99	0.99	
Normal Stress - psi	10.0	20.0	40.0	40.0	40.0	
Peak Failure Stress-psi	15.4	22.8	42.2	42.2	42.2	
Post Peak Failure Stress-psi	8.5	14.8	31.2	31.2	31.2	
Strain Rate - inches/min.	0.00300	0.00300	0.00300	0.00300	0.00300	
Peak Failure Strain - %	17.6	3.0	3.6	3.6	3.6	
Post Peak Failure Strain %	15.0	15.6	13.8	13.8	13.8	
Dry Density at test based on initial moisture and height at end of consolidation.						

TEST DESCRIPTION	PROJECT INFORMATION
TYPE OF TEST & NO: CD-DS-2 SAMPLE TYPE: Re-Compacted DESCRIPTION: Economized Ash, tan and gray SAMPLE LOCATION: MLSES (Bulk) SPECIFIC GRAVITY: 2.67 LL: NP PL: NP PI: NP Percent -200: 8.64 REMARKS: Multi-Specimen	PROJECT: Luminant Martin Lake PDP 1-3 LOCATION: Rusk , TX PROJECT NO: ETT08002-07 (G2810-08) CLIENT : E TTL Engineers & Consultants, Inc DATE: 5/20/08 <div style="display: flex; justify-content: space-between; margin-top: 10px;"> GREGORY GEOTECHNICAL PLATE: B-DS.3 </div>

PROJECT INFORMATION

PROJECT: Martin Lake PDP 1 - 3 Supplemental
LOCATION:
PROJECT NO: G 3219 - 09
CLIENT: HDR
September 2009

TRIAxIAL TEST PROGRAM BY GARRY H. GREGORY, P.E.

ALL RIGHTS RESERVED - UNAUTHORIZED USE PROHIBITED
VERSION 1.0 - AUGUST 1998 - REVISED MARCH 24, 1999

THIS COPY LICENSED TO:
ETTL ENGINEERS AND CONSULTANTS, INC.
1717 East Erwin
Tyler, TX 75702

TEST DESCRIPTION

TYPE OF TEST & NO: CU with PP
SAMPLE TYPE: Native Shelby Tube Sample
DESCRIPTION: Tan w/ Red & Gray Clayey Sand
Sampled on Site, B-16 8' to 10' deep
ASSUMED SPECIFIC GRAVITY: 2.7 + 40 Sieve
LL: PL: Pt: Percent -200:
REMARKS: Diameter and Both Ends Trimmed + # 4 Sieve

PLATE: B.1

PLATE: B.2

PLATE: B.3

Number of Specimens = 3

LUMINANT

TRIAxIAL SHEAR TEST REPORT

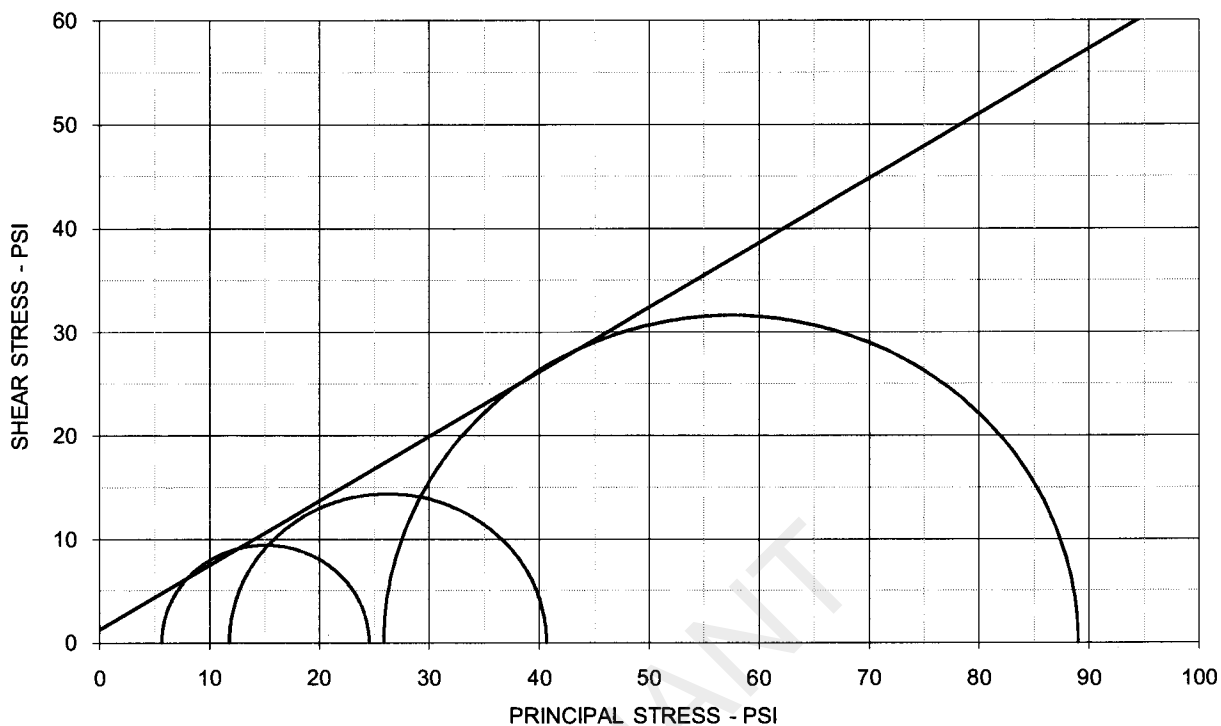

EFFECTIVE STRESS PARAMETERS

$\phi' = 31.9 \text{ deg}$ $c' = 1.3 \text{ psi}$

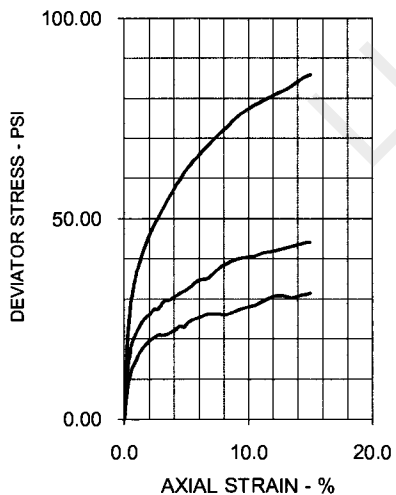

SPECIMEN NO.	1	2	3	4
INITIAL				
Moisture Content - %	17.2	16.8	16.3	
Dry Density - pcf	112.6	114.4	115.0	
Diameter - inches	2.47	2.46	2.48	
Height - inches	4.98	4.97	5.00	
AT TEST				
Final Moisture - %	18.4	16.5	16.0	
Dry Density - pcf	113.1	115.3	116.9	
Calculated Diameter (in.)	2.47	2.46	2.50	
Height - inches	5.00	4.97	5.06	
Effect. Cell Pressure - psi	10.0	20.0	40.0	
Failure Stress - psi	18.88	28.83	63.14	
Total Pore Pressure - psi	54.3	58.2	64.1	
Strain Rate - inches/min.	0.00050	0.00050	0.00050	
Failure Strain - %	1.8	3.0	5.2	
σ_1' Failure - psi	24.54	40.64	89.01	
σ_3' Failure - psi	5.66	11.81	25.87	

TEST DESCRIPTION

TYPE OF TEST & NO: CU with PP
 SAMPLE TYPE: Native Shelby Tube Sample
 DESCRIPTION: Tan w/ Red & Gray Clayey Sand
 Sampled on Site, B-16 8' to 10' deep
 ASSUMED SPECIFIC GRAVITY: 2.7 + 40 Sieve
 LL: PL: PI: Percent -200:
 REMARKS: Diameter and Both Ends Trimmed + # 4 Sieve
 G 3219-09, B-16-0-16 Native

PROJECT INFORMATION

PROJECT: Martin Lake PDP 1 - 3 Supplemental
 LOCATION:
 PROJECT NO: G 3219 - 09
 CLIENT: HDR
 September 2009

ETTL ENGINEERS & CONSULTANTS

PLATE: B.1

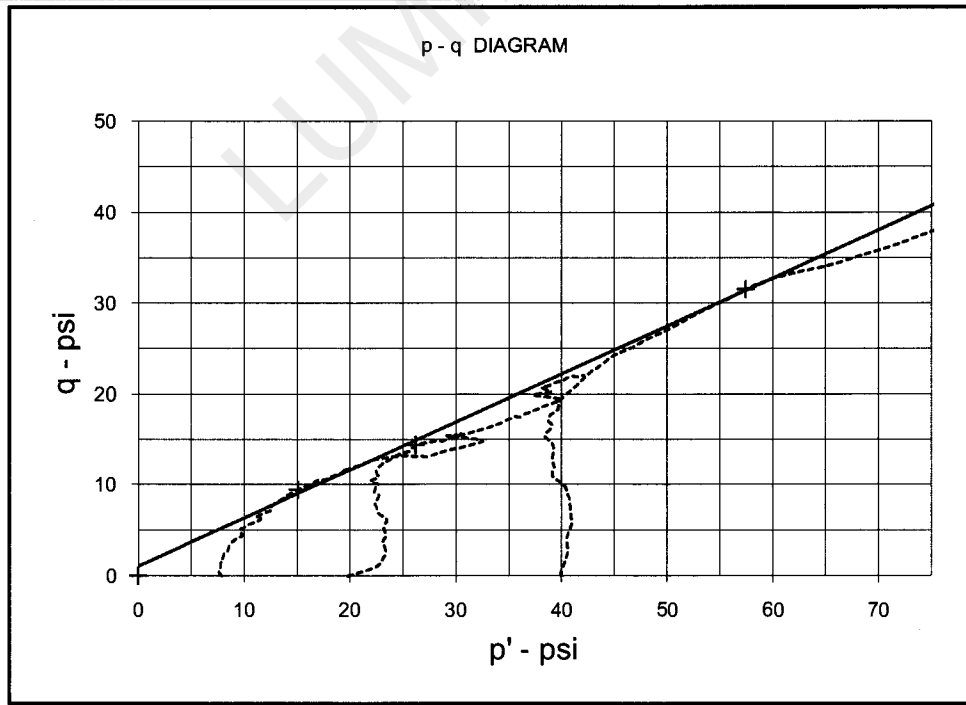
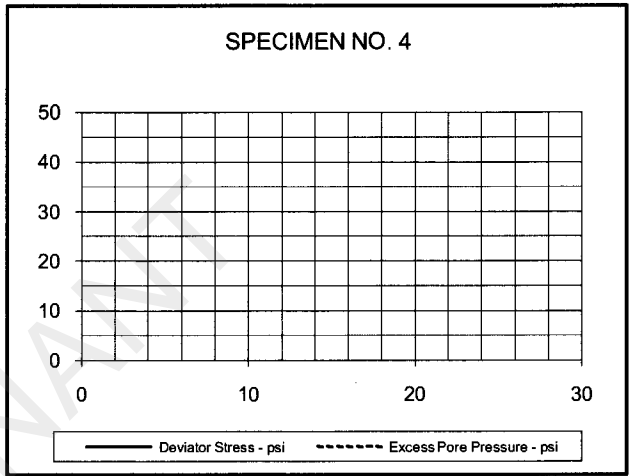
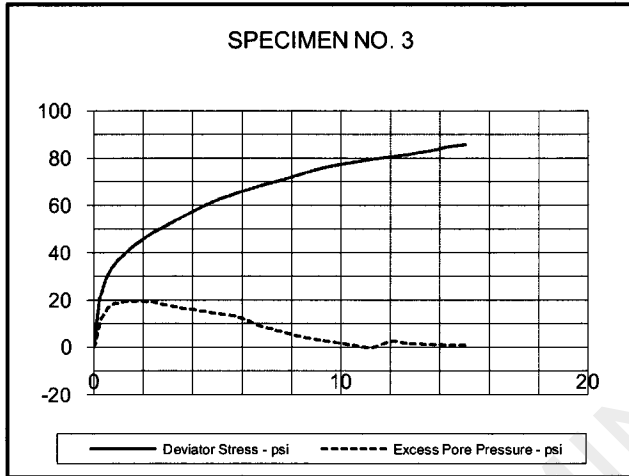
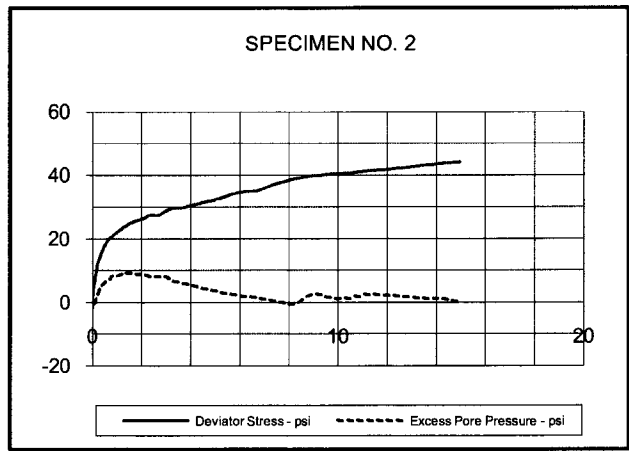
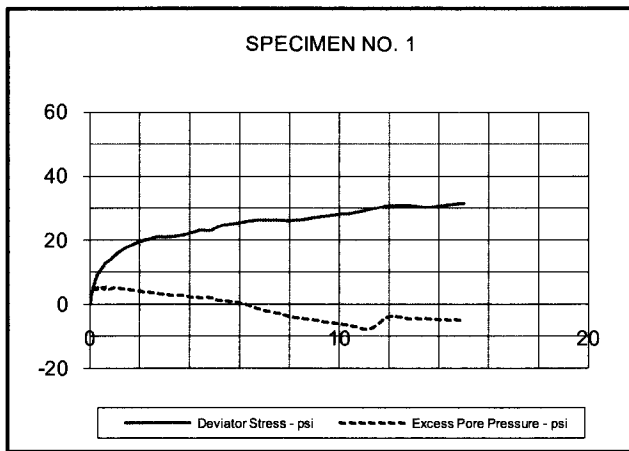

EFFECTIVE STRESS PARAMETERS	$R^2 = 1.00$	α (deg) = 27.9	a (psi) = 1.1
PROJECT: Martin Lake PDP 1 - 3 Supplemental		TYPE OF TEST & NO: CU with PP	
PROJECT NO: G 3219 - 09		ETTL ENGINEERS & CONSULTANTS	PLATE: B.2
DESCRIPTION: Tan w/ Red & Gray Clayey Sand			

G 3219-09, B-16 8'-10' Native

TRIAxIAL SHEAR TEST REPORT

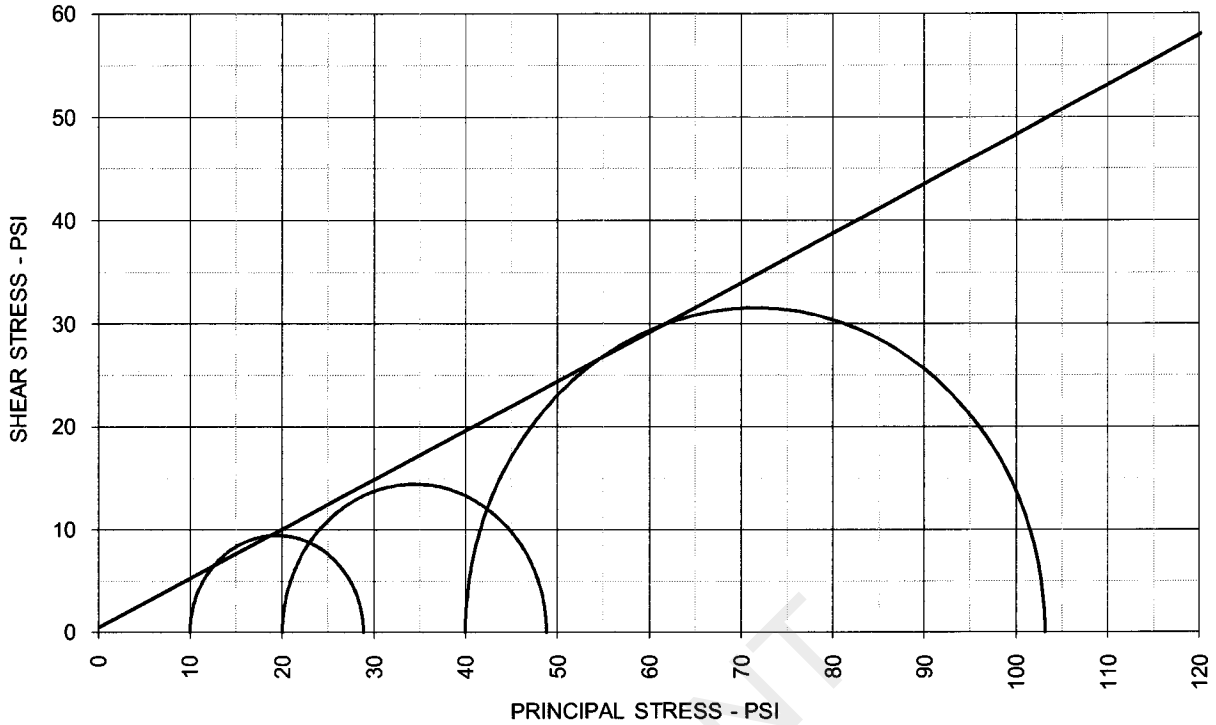

TOTAL STRESS PARAMETERS

$\phi = 25.6 \text{ deg}$

$c = 0.5 \text{ psi}$

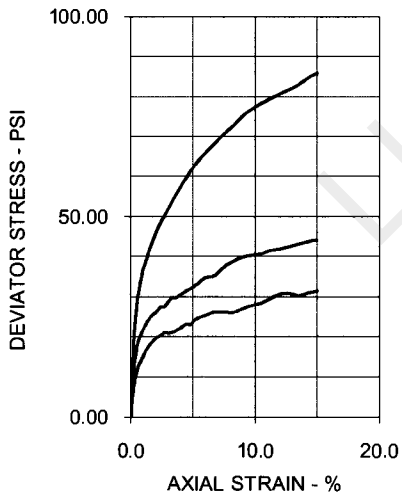

SPECIMEN NO.

	1	2	3	4
--	---	---	---	---

INITIAL

Moisture Content - %	17.2	16.8	16.3
Dry Density - pcf	112.6	114.4	115.0
Diameter - inches	2.47	2.46	2.48
Height - inches	4.98	4.97	5.00

AT TEST

Final Moisture - %	18.4	16.5	16.0
Dry Density - pcf	113.1	115.3	116.9
Calculated Diameter (in.)	2.47	2.46	2.50
Height - inches	5.00	4.97	5.06
Effect. Cell Pressure - psi	10.0	20.0	40.0
Failure Stress - psi	18.88	28.83	63.14
Total Pore Pressure - psi	54.3	58.2	64.1
Strain Rate - inches/min.	0.00050	0.00050	0.00050
Failure Strain - %	1.8	3.0	5.2
σ_1 Failure - psi	28.88	48.83	103.14
σ_3 Failure - psi	10.00	20.00	40.00

TEST DESCRIPTION

TYPE OF TEST & NO: CU with PP
 SAMPLE TYPE: Native Shelby Tube Sample
 DESCRIPTION: Tan w/ Red & Gray Clayey Sand
 Sampled on Site, B-16 8' to 10' deep
 ASSUMED SPECIFIC GRAVITY: 2.7 + 40 Sieve
 LL: PL: PI: Percent -200:
 REMARKS: Diameter and Both Ends Trimmed + # 4 Sieve

PROJECT INFORMATION

PROJECT: Martin Lake PDP 1 - 3 Supplemental
 LOCATION:
 PROJECT NO: G 3219 - 09
 CLIENT: HDR
 September 2009

Ettl ENGINEERS & CONSULTANTS

PLATE: B.3

PROJECT INFORMATION

PROJECT: Martin Lake PDP 1 - 3 Supplemental
LOCATION:
PROJECT NO: G 3219 - 09
CLIENT: HDR
September 2009

TRIAxIAL TEST PROGRAM BY GARRY H. GREGORY, P.E.

ALL RIGHTS RESERVED - UNAUTHORIZED USE PROHIBITED
VERSION 1.0 - AUGUST 1998 - REVISED MARCH 24, 1999

THIS COPY LICENSED TO:
ETTL ENGINEERS AND CONSULTANTS, INC.
1717 East Erwin
Tyler, TX 75702

TEST DESCRIPTION

TYPE OF TEST & NO: CU with PP
SAMPLE TYPE: Native Shelby Tube Sample
DESCRIPTION: Tan & Red Sandy Lean Clay
Sampled on Site, B-17 3' to 7' deep
ASSUMED SPECIFIC GRAVITY: 2.7 + 40 Sieve
LL: PL: Pt: Percent -200:
REMARKS: Diameter and Both Ends Trimmed + # 4 Sieve

PLATE: B.1

PLATE: B.2

PLATE: B.3

Number of Specimens = 3

TRIAxIAL SHEAR TEST REPORT

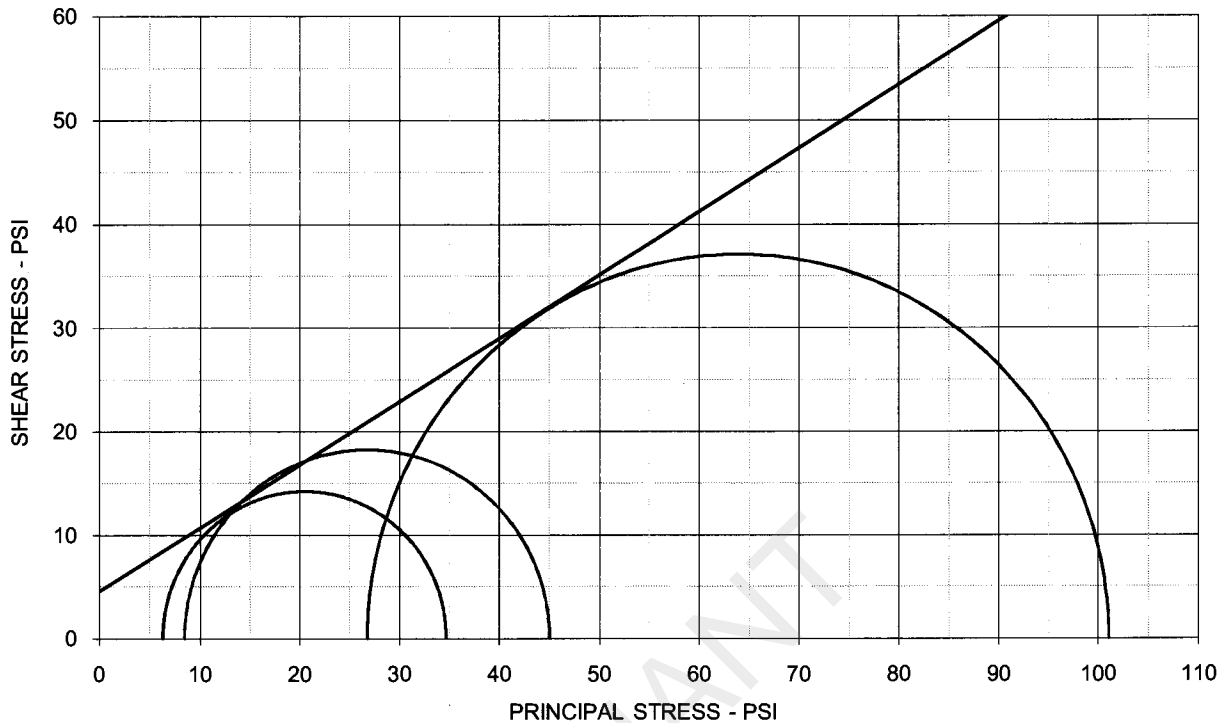

EFFECTIVE STRESS PARAMETERS

$\phi' = 31.4$ deg $c' = 4.6$ psi

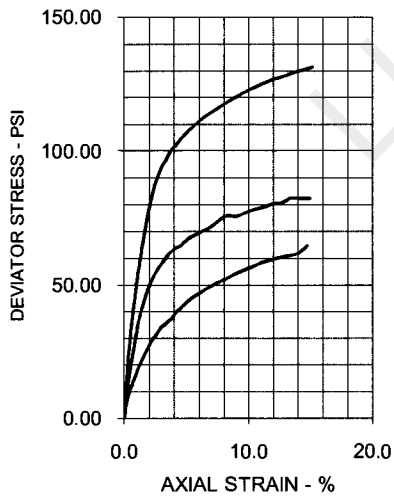

SPECIMEN NO.	1	2	3	4
INITIAL				
Moisture Content - %	16.2	13.3	13.9	
Dry Density - pcf	113.5	121.6	115.5	
Diameter - inches	2.49	2.49	2.50	
Height - inches	5.08	5.00	5.16	
AT TEST				
Final Moisture - %	18.1	14.7	16.3	
Dry Density - pcf	114.1	123.3	117.2	
Calculated Diameter (in.)	2.50	2.50	2.52	
Height - inches	5.10	5.04	5.22	
Effect. Cell Pressure - psi	10.0	20.0	40.0	
Failure Stress - psi	28.40	36.54	74.24	
Total Pore Pressure - psi	53.7	61.5	63.2	
Strain Rate - inches/min.	0.00050	0.00050	0.00050	
Failure Strain - %	0.8	3.5	1.8	
σ'_1 Failure - psi	34.71	45.04	101.03	
σ'_3 Failure - psi	6.31	8.50	26.79	

TEST DESCRIPTION

TYPE OF TEST & NO: CU with PP
 SAMPLE TYPE: Native Shelby Tube Sample
 DESCRIPTION: Tan & Red Sandy Lean Clay
 Sampled on Site, B-17 3' to 7' deep
 ASSUMED SPECIFIC GRAVITY: 2.7 + 40 Sieve
 LL: PL: PI: Percent -200:
 REMARKS: Diameter and Both Ends Trimmed + # 4 Sieve
 G 3219-09, B-17 3-7 Native

PROJECT INFORMATION

PROJECT: Martin Lake PDP 1 - 3 Supplemental
 LOCATION:
 PROJECT NO: G 3219 - 09
 CLIENT: HDR
 September 2009

ETTL ENGINEERS & CONSULTANTS

PLATE: B.1

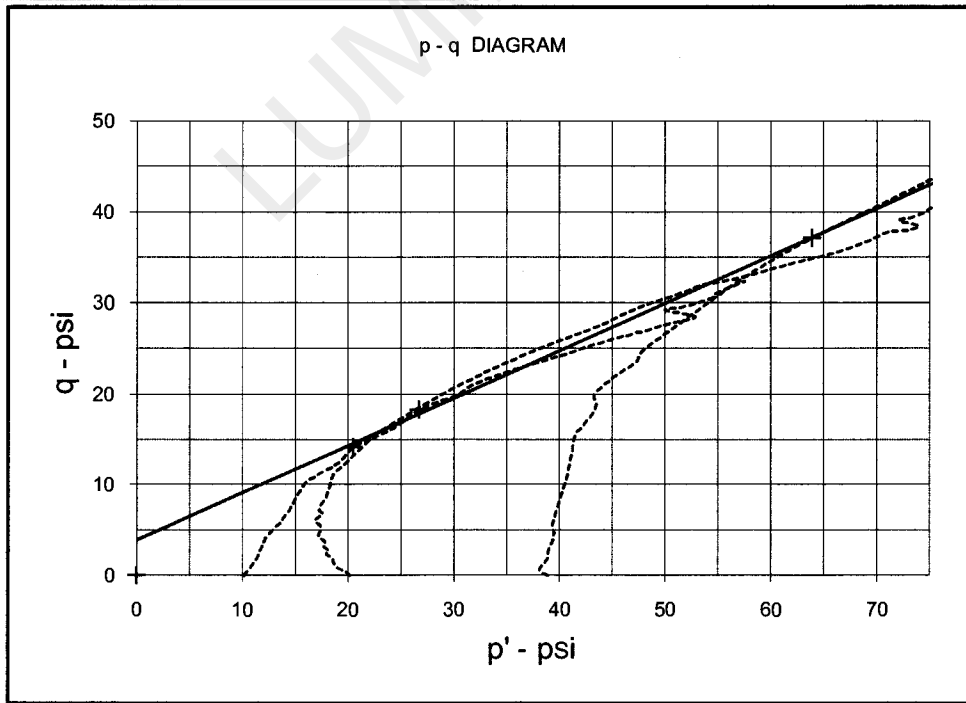
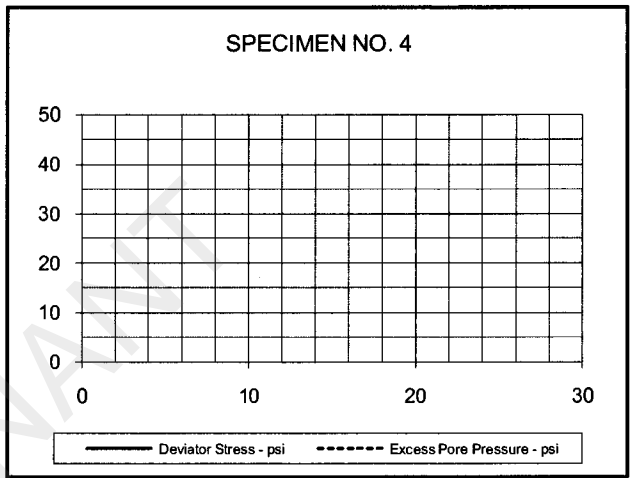
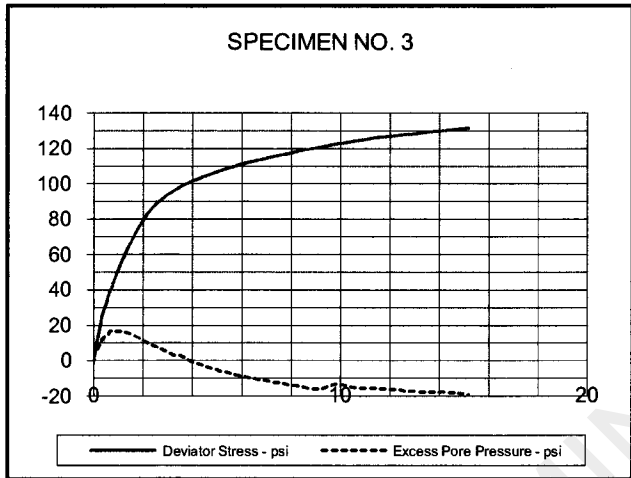
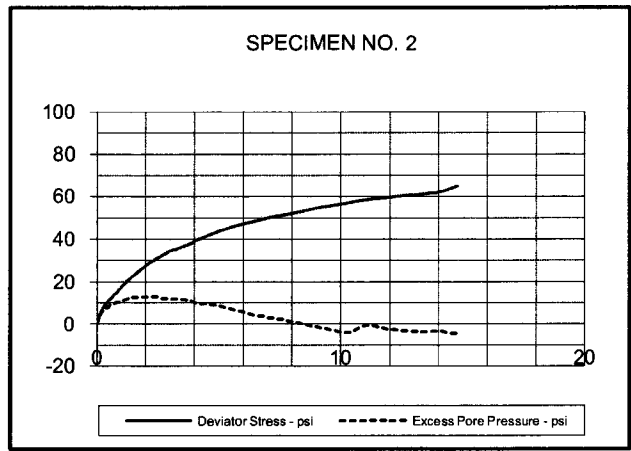
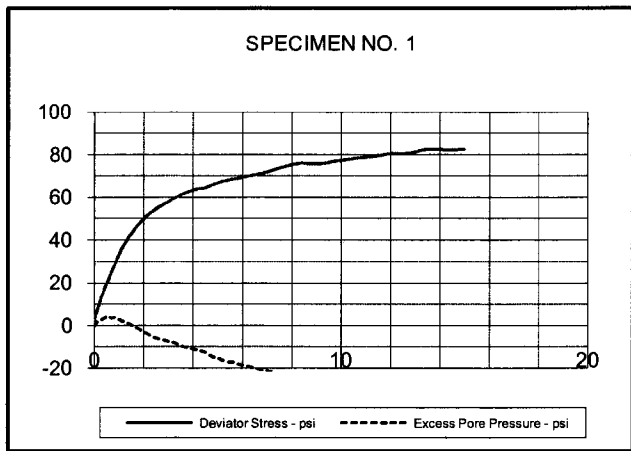

EFFECTIVE STRESS PARAMETERS	$R^2 = 1.00$	α (deg) = 27.5	a (psi) = 3.9
PROJECT: Martin Lake PDP 1 - 3 Supplemental		TYPE OF TEST & NO: CU with PP	
PROJECT NO: G 3219 - 09		ETTL ENGINEERS & CONSULTANTS	PLATE: B.2
DESCRIPTION: Tan & Red Sandy Lean Clay			

G 3219-09, B-17 3'-7' Native

TRIAxIAL SHEAR TEST REPORT

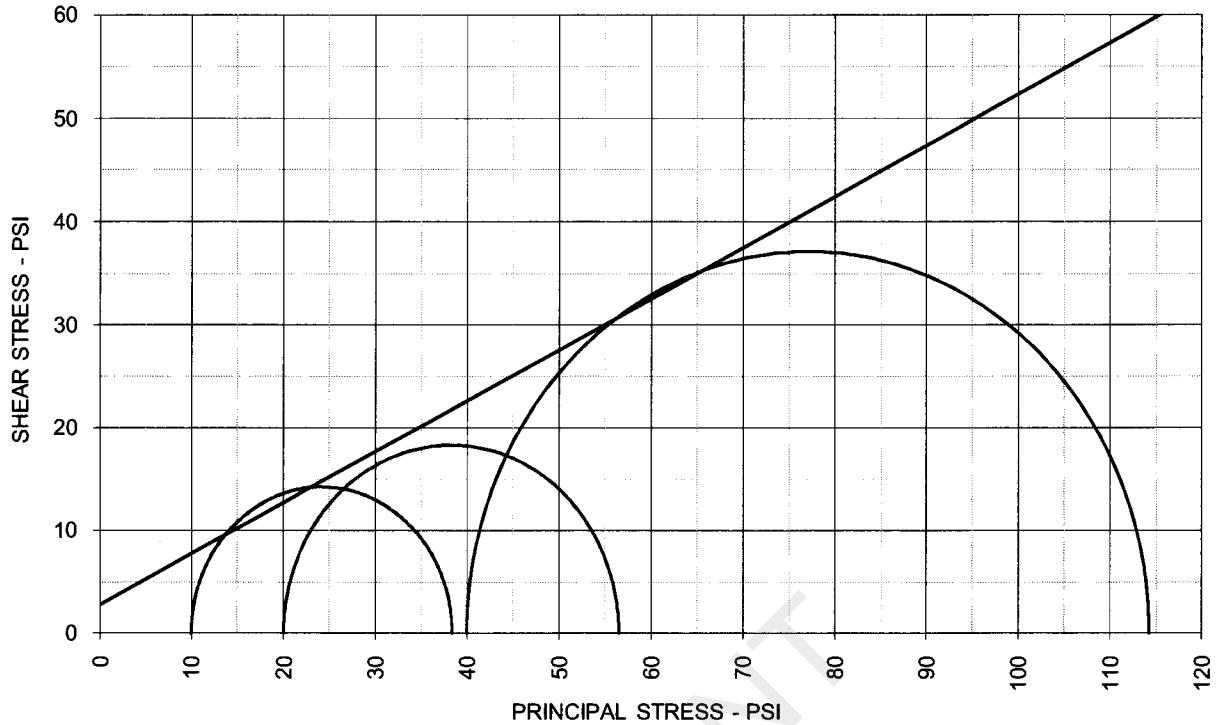

TOTAL STRESS PARAMETERS		$\phi = 26.4 \text{ deg}$	$c = 2.8 \text{ psi}$		
	SPECIMEN NO.	1	2	3	
	INITIAL				
	Moisture Content - %	16.2	13.3	13.9	13.9
	Dry Density - pcf	113.5	121.6	115.5	115.5
	Diameter - inches	2.49	2.49	2.50	2.50
	Height - inches	5.08	5.00	5.16	5.16
	AT TEST				
	Final Moisture - %	18.1	14.7	16.3	16.3
	Dry Density - pcf	114.1	123.3	117.2	117.2
	Calculated Diameter (in.)	2.50	2.50	2.52	2.52
Height - inches	5.10	5.04	5.22	5.22	
Effect. Cell Pressure - psi	10.0	20.0	40.0	40.0	
Failure Stress - psi	28.40	36.54	74.24	74.24	
Total Pore Pressure - psi	53.7	61.5	63.2	63.2	
Strain Rate - inches/min.	0.00050	0.00050	0.00050	0.00050	
Failure Strain - %	0.8	3.5	1.8	1.8	
σ_1 Failure - psi	38.40	56.54	114.24	114.24	
σ_3 Failure - psi	10.00	20.00	40.00	40.00	
TEST DESCRIPTION		PROJECT INFORMATION			
TYPE OF TEST & NO: CU with PP SAMPLE TYPE: Native Shelby Tube Sample DESCRIPTION: Tan & Red Sandy Lean Clay Sampled on Site, B-17 3' to 7' deep ASSUMED SPECIFIC GRAVITY: 2.7 + 40 Sieve LL: PL: PI: Percent -200: REMARKS: Diameter and Both Ends Trimmed + # 4 Sieve		PROJECT: Martin Lake PDP 1 - 3 Supplemental LOCATION: PROJECT NO: G 3219 - 09 CLIENT: HDR September 2009			
		ETTL ENGINEERS & CONSULTANTS	PLATE: B.3		

PROJECT INFORMATION

PROJECT: Martin Lake PDP 1 - 3 Supplemental
LOCATION:
PROJECT NO: G 3219 - 09
CLIENT: HDR
September 2009

TRIAxIAL TEST PROGRAM BY GARRY H. GREGORY, P.E.

ALL RIGHTS RESERVED - UNAUTHORIZED USE PROHIBITED
VERSION 1.0 - AUGUST 1998 - REVISED MARCH 24, 1999

THIS COPY LICENSED TO:
ETTL ENGINEERS AND CONSULTANTS, INC.
1717 East Erwin
Tyler, TX 75702

TEST DESCRIPTION

TYPE OF TEST & NO: CU with PP
SAMPLE TYPE: Lab Molded
DESCRIPTION: Tan & Reddish Tan Silty Sand
Sampled on Site, TP- 31 0' to 5' deep
ASSUMED SPECIFIC GRAVITY: 2.7 + 40 Sieve 2%
LL: 20 PL: 17 Pt: 3 Percent -200: 27%
REMARKS: Both Ends Trimmed + # 4 Sieve 1%

PLATE: B.1

PLATE: B.2

PLATE: B.3

Number of Specimens = 3

LUMINANT

TRIAxIAL SHEAR TEST REPORT

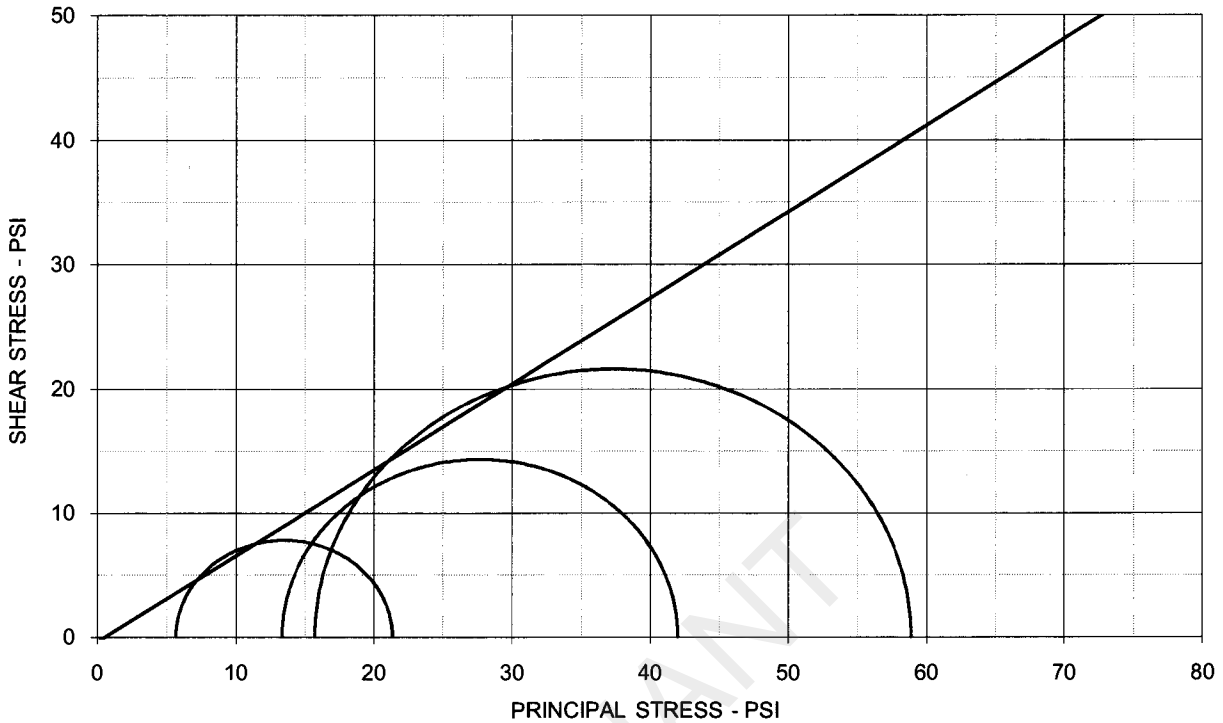

EFFECTIVE STRESS PARAMETERS

$\phi' = 34.7 \text{ deg}$

$c' = -0.4 \text{ psi}$

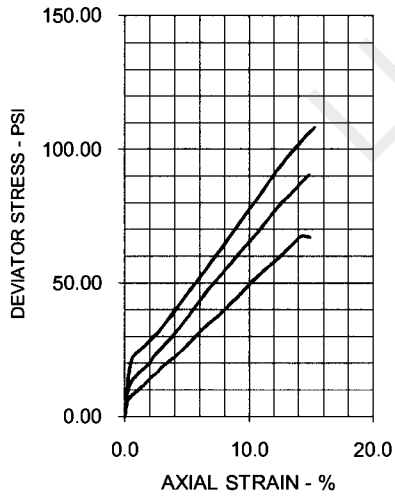

SPECIMEN NO.

1 2 3 4

INITIAL

Moisture Content - %	17.3	17.2	17.4
Dry Density - pcf	110.3	110.5	110.4
Diameter - inches	2.87	2.87	2.85
Height - inches	5.57	5.59	5.61

AT TEST

Final Moisture - %	17.2	16.7	16.5
Dry Density - pcf	110.6	111.6	112.0
Calculated Diameter (in.)	2.87	2.88	2.87
Height - inches	5.58	5.62	5.66
Effect. Cell Pressure - psi	10.0	20.0	40.0
Failure Stress - psi	15.65	28.63	43.17
Total Pore Pressure - psi	54.3	56.7	74.3
Strain Rate - inches/min.	0.00050	0.00050	0.00050
Failure Strain - %	2.4	3.5	4.6
σ_1' Failure - psi	21.35	41.97	58.90
σ_3' Failure - psi	5.70	13.34	15.73

TEST DESCRIPTION

TYPE OF TEST & NO: CU with PP
 SAMPLE TYPE: Lab Molded
 DESCRIPTION: Tan & Reddish Tan Silty Sand
 Sampled on Site, TP- 31 0' to 5' deep
 ASSUMED SPECIFIC GRAVITY: 2.7 + 40 Sieve 2%
 LL: 20 PL: 17 PI: 3 Percent -200: 27%
 REMARKS: Both Ends Trimmed + # 4 Sieve 1%
 G 3219-09, TP-31 0-5 Lab Molded

PROJECT INFORMATION

PROJECT: Martin Lake PDP 1 - 3 Supplemental
 LOCATION:
 PROJECT NO: G 3219 - 09
 CLIENT: HDR
 September 2009

ETTL ENGINEERS & CONSULTANTS

PLATE: B.1

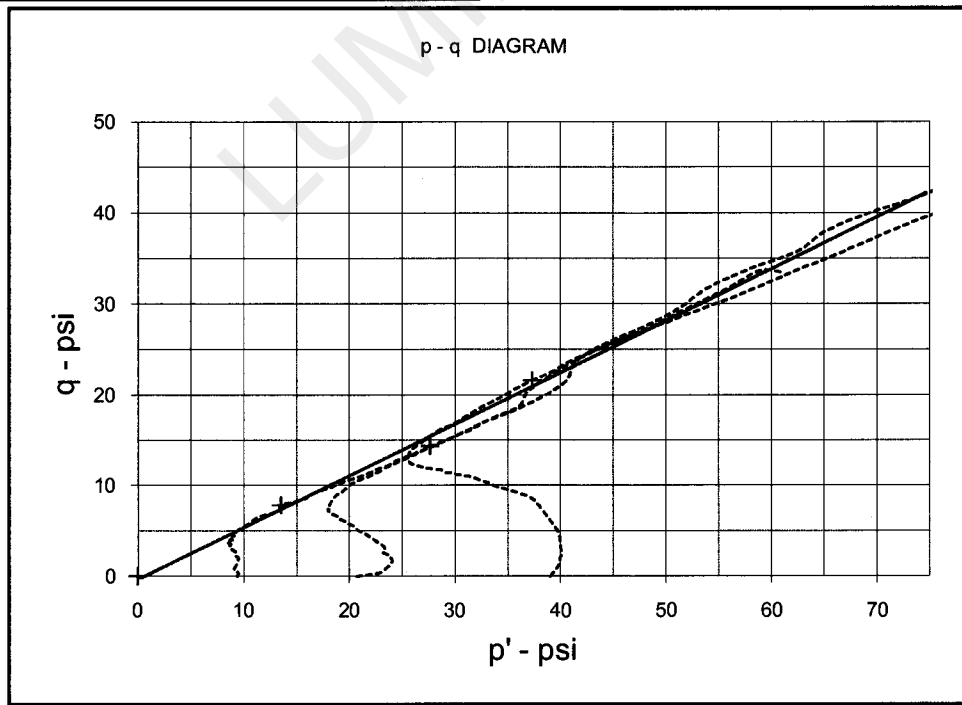
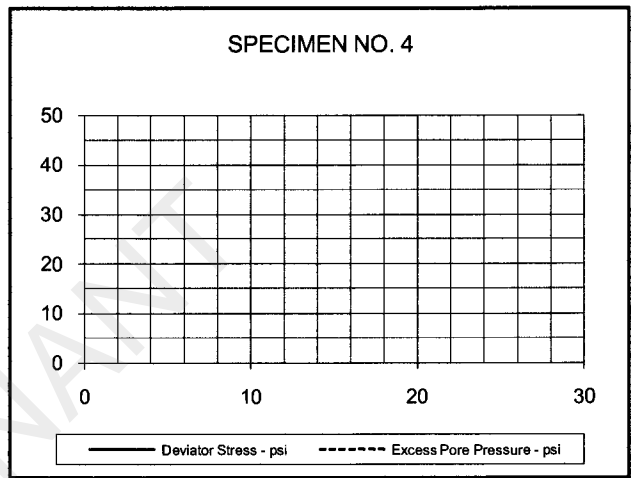
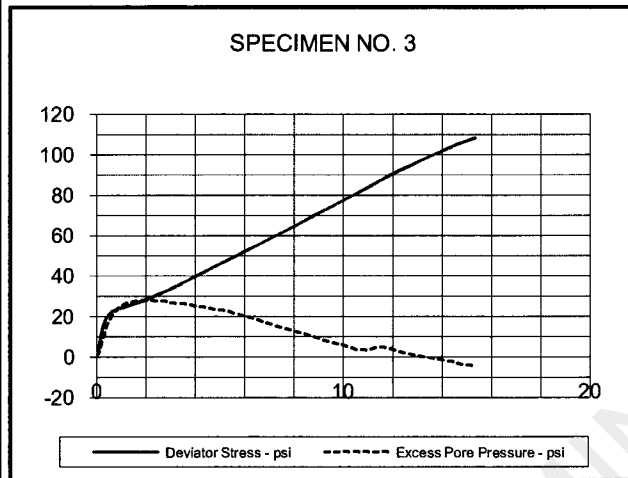
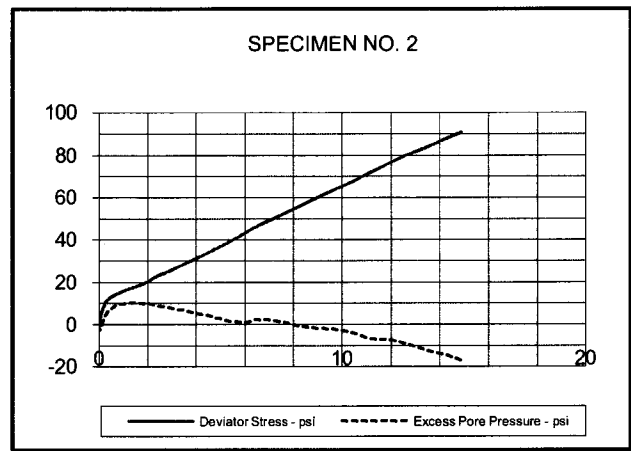
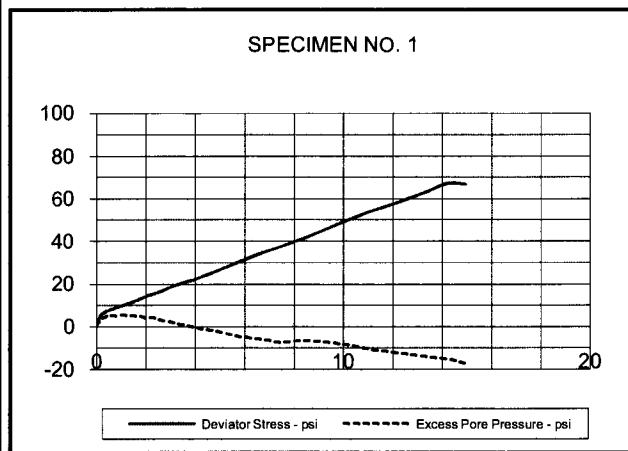

EFFECTIVE STRESS PARAMETERS	$R^2 = 0.98$	α (deg) = 29.7	a (psi) = -0.3
PROJECT: Martin Lake PDP 1 - 3 Supplemental	TYPE OF TEST & NO: CU with PP		
PROJECT NO: G 3219 - 09	ETTL ENGINEERS & CONSULTANTS		PLATE: B.2
DESCRIPTION: Tan & Reddish Tan Silty Sand			

G 3219-09, TP-31 0'-5' Lab Molded

TRIAxIAL SHEAR TEST REPORT

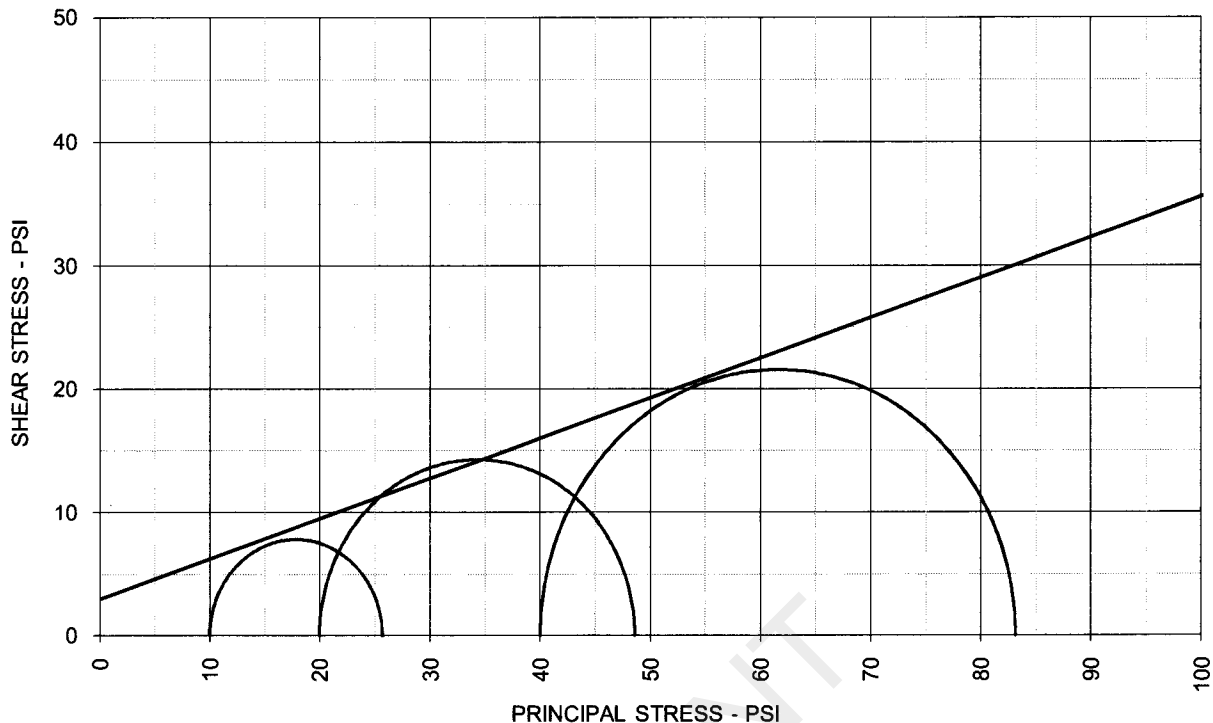

TOTAL STRESS PARAMETERS	$\phi = 18.0 \text{ deg}$	$c = 3.0 \text{ psi}$
--------------------------------	---------------------------	-----------------------

	SPECIMEN NO.	1	2	3	4	
	INITIAL					
	Moisture Content - %	17.3	17.2	17.4	17.4	17.4
	Dry Density - pcf	110.3	110.5	110.4	110.4	110.4
	Diameter - inches	2.87	2.87	2.85	2.85	2.85
	Height - inches	5.57	5.59	5.61	5.61	5.61
	AT TEST					
	Final Moisture - %	17.2	16.7	16.5	16.5	16.5
	Dry Density - pcf	110.6	111.6	112.0	112.0	112.0
	Calculated Diameter (in.)	2.87	2.88	2.87	2.87	2.87
Height - inches	5.58	5.62	5.66	5.66	5.66	
Effect. Cell Pressure - psi	10.0	20.0	40.0	40.0	40.0	
Failure Stress - psi	15.65	28.63	43.17	43.17	43.17	
Total Pore Pressure - psi	54.3	56.7	74.3	74.3	74.3	
Strain Rate - inches/min.	0.00050	0.00050	0.00050	0.00050	0.00050	
Failure Strain - %	2.4	3.5	4.6	4.6	4.6	
σ_1 Failure - psi	25.65	48.63	83.17	83.17	83.17	
σ_3 Failure - psi	10.00	20.00	40.00	40.00	40.00	

TEST DESCRIPTION	PROJECT INFORMATION
TYPE OF TEST & NO: CU with PP SAMPLE TYPE: Lab Molded DESCRIPTION: Tan & Reddish Tan Silty Sand Sampled on Site, TP- 31 0' to 5' deep ASSUMED SPECIFIC GRAVITY: 2.7 + 40 Sieve 2% LL: 20 PL: 17 PI: 3 Percent -200: 27% REMARKS: Both Ends Trimmed + # 4 Sieve 1%	PROJECT: Martin Lake PDP 1 - 3 Supplemental LOCATION: PROJECT NO: G 3219 - 09 CLIENT: HDR September 2009 <div style="display: flex; justify-content: space-between; margin-top: 10px;"> ETTL ENGINEERS & CONSULTANTS PLATE: B.3 </div>

TRIAxIAL SHEAR TEST REPORT

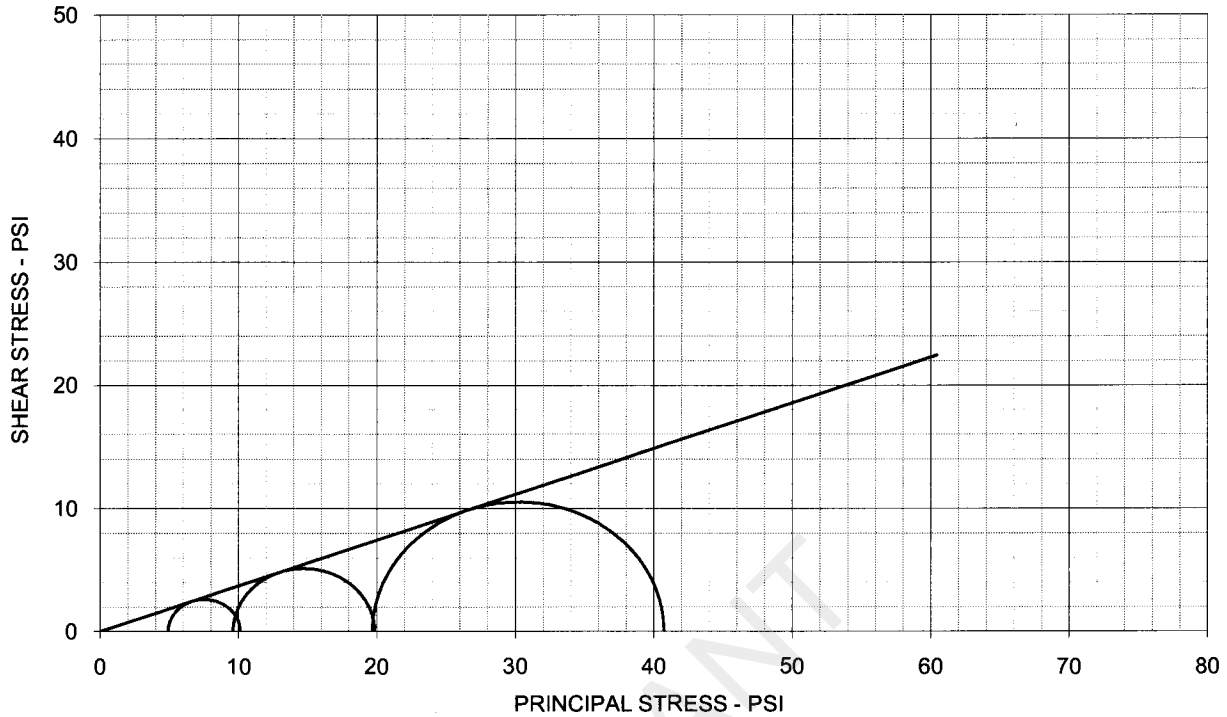

EFFECTIVE STRESS PARAMETERS

$\phi' = 20.4 \text{ deg}$ $c' = 0.0 \text{ psi}$

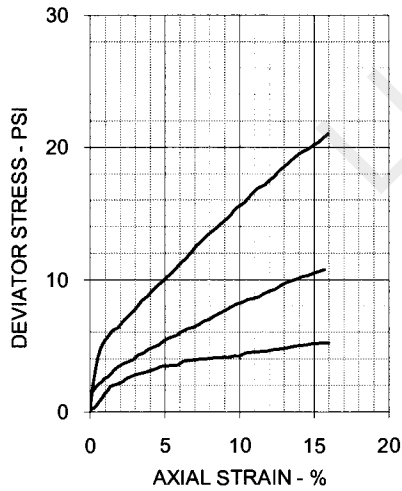

SPECIMEN NO.	1	2	3	4
INITIAL				
Moisture Content - %	26.1	24.6	21.3	
Dry Density - pcf	94.3	95.8	101.6	
Diameter - inches	1.40	1.40	1.40	
Height - inches	2.81	2.85	3.20	
AT TEST				
Final Moisture - %	26.1	24.6	21.3	
Dry Density - pcf	94.3	97.0	101.6	
Calculated Diameter (in.)	1.40	1.40	1.40	
Height - inches	2.81	2.85	3.20	
Effect. Cell Pressure - psi	5.0	10.0	20.0	
Failure Stress - psi	5.21	10.25	21.03	
Total Pore Pressure - psi	20.0	20.0	20.0	
Strain Rate - inches/min.	0.00050	0.00050	0.00050	
Failure Strain - %	15.6	14.2	15.9	
σ_1' Failure - psi	10.11	19.85	40.73	
σ_3' Failure - psi	4.90	9.60	19.70	

TEST DESCRIPTION

TYPE OF TEST & NO: CD Triaxial - CD-1
 SAMPLE TYPE: SHELBY TUBE
 DESCRIPTION: SANDY LEAN CLAY (CL), tan br w/ red br and gray
 SAMPLE LOCATION: B-16, 3-5'
 ASSUMED SPECIFIC GRAVITY: 2.70
 LL: 43 PL: 14 PI: 29 Percent -200: 56
 REMARKS: Tested in a fully softened remolded state

PROJECT INFORMATION

PROJECT: Luminant Martin Lake PDP 1-3 Vertical Expansion
 LOCATION: Tatum, TX
 PROJECT NO: ETT08002-11
 CLIENT: E TTL Engineers & Consultants, Inc.
 DATE: 9/15/09

GREGORY GEOTECHNICAL

PLATE: B-CD.1

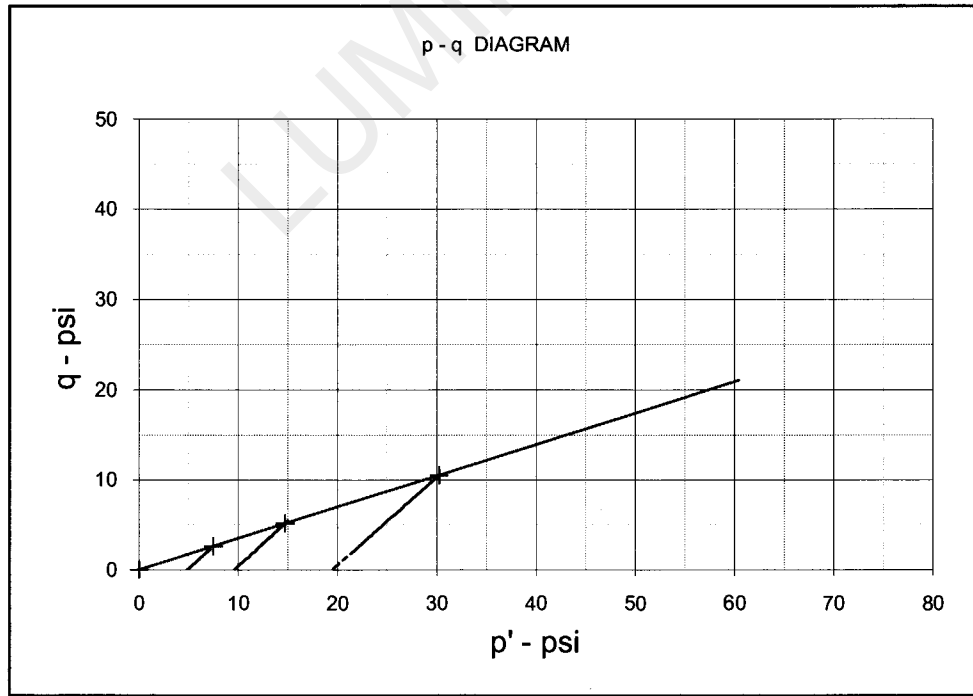
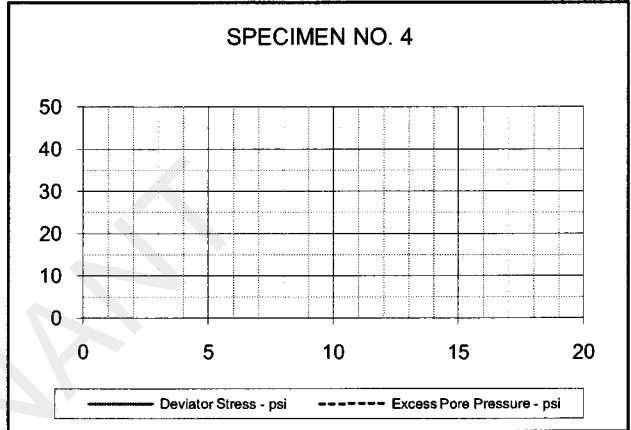
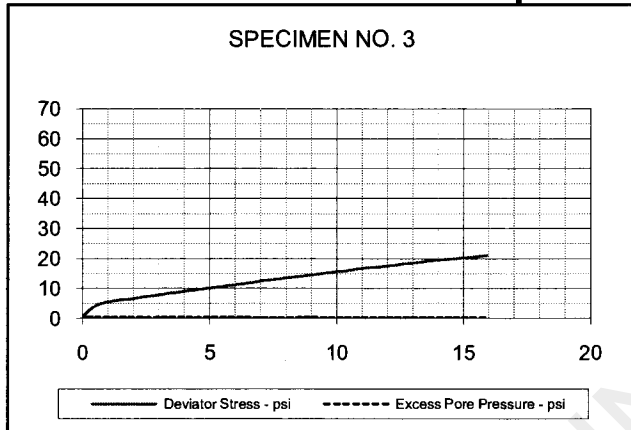
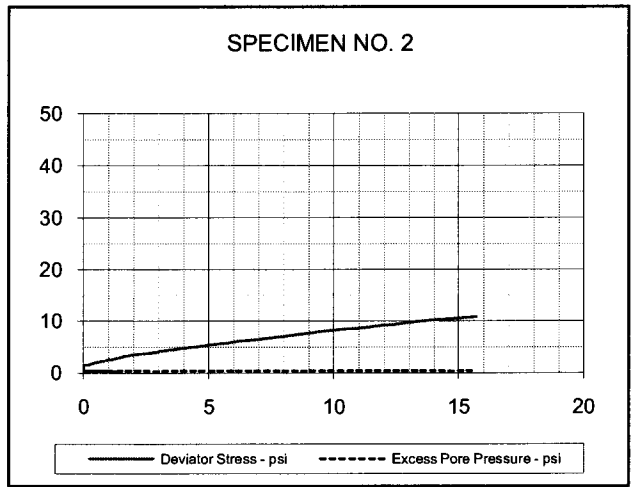
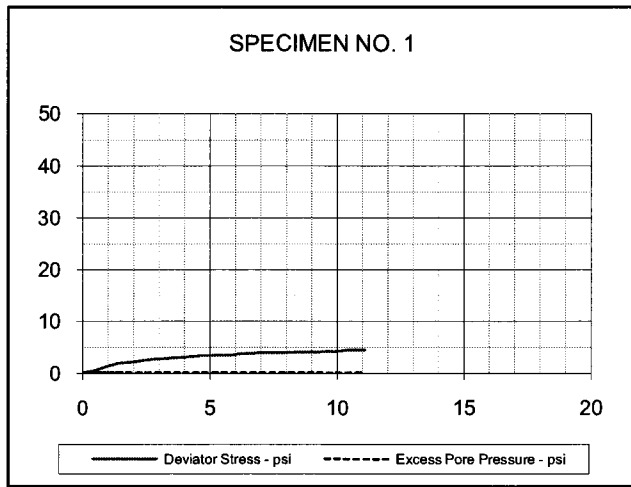

EFFECTIVE STRESS PARAMETERS	$R^2 = 1.000$	α (deg) = 19.2	a (psi) = 0.0
PROJECT: Luminant Martin Lake PDP 1-3 Vertical Expansion	TYPE OF TEST & NO: CD Triaxial - CD-1		
PROJECT NO: ETT08002-11	GREGORY GEOTECHNICAL		
DESCRIPTION: SANDY LEAN CLAY (CL), tan br w/ red br and gray			

DIRECT SHEAR TEST REPORT

$y = 0.815x + 1.35$
 $R^2 = 0.980$

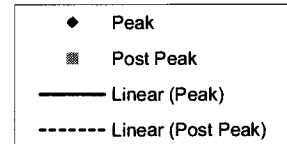
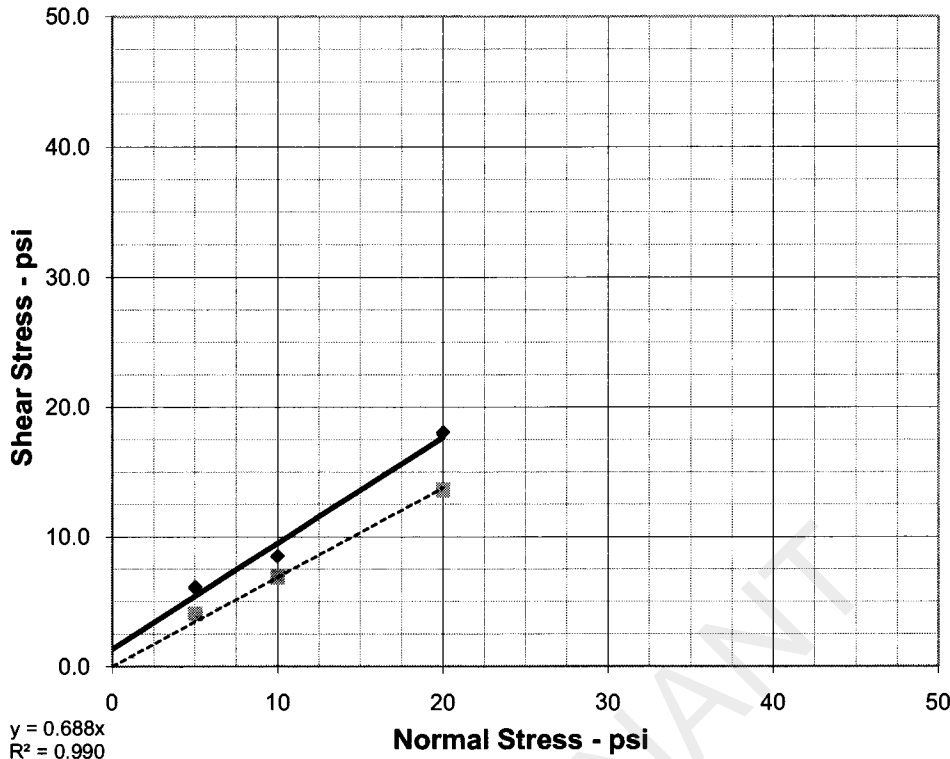

PEAK STRENGTH PARAMETERS	$\phi = 39.2 \text{ deg}$	$c = 1.4 \text{ psi}$
POST PEAK STRENGTH PARAMETERS	$\phi = 34.6 \text{ deg}$	$c = 0.0 \text{ psi}$

	SPECIMEN NO.	1	2	3	4	
	INITIAL					
	Moisture Content - %	41.3	42.3	48.4		
	Dry Density - pcf	78.9	72.5	72.9		
	Diameter - inches	2.50	2.50	2.50		
	Height - inches	1.00	1.00	1.00		
	AT TEST					
	Final Moisture - %	46.6	59.5	31.6		
	Dry Density - pcf	81.0	74.2	73.0		
	Height-End of Consol. (in.)	1.03	1.02	1.00		
Height-End of Shear (in.)	1.03	1.03	1.01			
Normal Stress - psi	5.0	10.0	20.0			
Peak Failure Stress-psi	6.1	8.5	18.0			
Post Peak Failure Stress-psi	4.1	6.9	13.6			
Strain Rate - inches/min.	0.00030	0.00030	0.00030			
Peak Failure Strain - %	1.6	1.9	3.1			
Post Peak Failure Strain %	4.3	12.7	11.8			
Dry Density at test based on initial moisture and height at end of consolidation.						

TEST DESCRIPTION	PROJECT INFORMATION
TYPE OF TEST & NO: CD-DS-1 SAMPLE TYPE: Shelby Tube DESCRIPTION: SILT(MH), black (classification tests from 13-15 ft) SAMPLE LOCATION: B-15, 18-20 ft ASSUMED SPECIFIC GRAVITY: 2.65 LL: NP PL: NP PI: NP Percent -200: 95 REMARKS: Tested at natural MC	PROJECT: Luminant Martin Lake PDP 1-3 Vertical Expansion LOCATION: Tatum, TX PROJECT NO: ETT08002-11 (G3219-09) CLIENT : E TTL Engineers & Consultants, Inc DATE: 9/25/09 <hr/> <div style="display: flex; justify-content: space-between;"> GREGORY GEOTECHNICAL PLATE: B-DS. 1 </div>

DIRECT SHEAR TEST REPORT

$y = 0.788x + 1.4$
 $R^2 = 0.99$

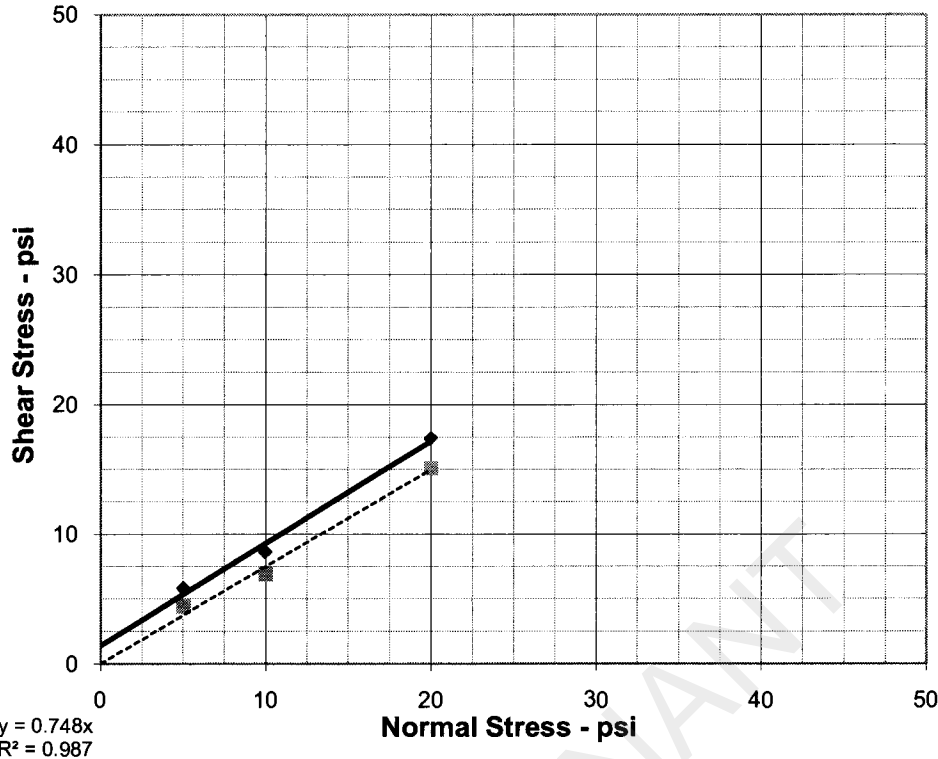

PEAK STRENGTH PARAMETERS	$\phi = 38.3 \text{ deg}$	$c = 1.4 \text{ psi}$
POST PEAK STRENGTH PARAMETERS	$\phi = 36.8 \text{ deg}$	$c = 0.0 \text{ psi}$

	SPECIMEN NO.	1	2	3	4	
	INITIAL					
	Moisture Content - %	47.2	47.5	46.5		
	Dry Density - pcf	77.0	73.3	72.6		
	Diameter - inches	2.50	2.50	2.50		
	Height - inches	1.00	1.00	1.00		
	AT TEST					
	Final Moisture - %	47.2	47.5	31.6		
	Dry Density - pcf	77.0	73.3	72.6		
	Height-End of Consol. (in.)	1.00	1.00	1.00		
Height-End of Shear (in.)	0.98	0.98	0.99			
Normal Stress - psi	5.0	10.0	20.0			
Peak Failure Stress-psi	5.8	8.6	17.4			
Post Peak Failure Stress-psi	4.4	6.9	15.1			
Strain Rate - inches/min.	0.00030	0.00030	0.00030			
Peak Failure Strain - %	3.1	15.0	3.1			
Post Peak Failure Strain %	7.8	6.8	12.8			
Dry Density at test based on initial moisture and height at end of consolidation.						

TEST DESCRIPTION	PROJECT INFORMATION		
TYPE OF TEST & NO: CD-DS-2 SAMPLE TYPE: Shelby Tube DESCRIPTION: SILT(MH), black (classification tests from 13-15 ft) SAMPLE LOCATION: B-15, 18-20 ft ASSUMED SPECIFIC GRAVITY: 2.65 LL: NP PL: NP PI: NP Percent -200: 95 REMARKS: Tested in a fully softened remolded state	PROJECT: Luminant Martin Lake PDP 1-3 Vertical Expansion LOCATION: Tatum, TX PROJECT NO: ETT08002-11 (G3219-09) CLIENT: E TTL Engineers & Consultants, Inc DATE: 9/23/09		
	<table border="1" style="width: 100%; border-collapse: collapse;"> <tr> <td style="width: 50%;">GREGORY GEOTECHNICAL</td> <td style="width: 50%;">PLATE: B-DS. 2</td> </tr> </table>	GREGORY GEOTECHNICAL	PLATE: B-DS. 2
GREGORY GEOTECHNICAL	PLATE: B-DS. 2		



ETTL Engineers & Consultants Inc.

GEOTECHNICAL * MATERIALS * ENVIRONMENTAL * DRILLING * LANDFILLS

HYDRAULIC CONDUCTIVITY DETERMINATION FLEXIBLE WALL PERMEAMETER - CONSTANT VOLUME (Mercury Permometer Test)

Project :	Martin Lake PDP 1 - 3 Supplemental, Tatum, Texas		
Date:	8/26/2009	Panel Number :	P 1 ; ASTM D 5084
Project No. :	G 3219-09	Permometer Data	
Boring No.:	B - 14	ap =	0.031416 cm ²
Sample:		aa =	0.767120 cm ²
Depth (ft):	3' to 5'	M1 =	0.030180
Other Location:		M2 =	1.040953
Material Description :	Dark Gray Ash		

Set Mercury to Dial at	Equilibrium	1.8	cm ³
	Pipet Rp	6.7	cm ³
	Annulus Ra	1.5	cm ³
	C =	0.000414194	
	T =	0.203859738	

SAMPLE DATA

Wet Wt. sample + ring or tare :	502.16	g			
Tare or ring Wt. :	0.0	g			
Wet Wt. of Sample :	502.16	g			
Diameter :	2.85	in	7.24	cm ²	
Length :	2.80	in	7.12	cm	
Area:	6.38	in ²	41.16	cm ²	
Volume :	17.88	in ³	292.92	cm ³	
Unit Wt. (wet):	106.97	pcf	1.71	g/cm ³	
Unit Wt. (dry):	68.77	pcf	1.10	g/cm ³	

	Before Test	After Test
Tare No.:	T 20	T 22
Wet Wt. +tare:	522.84	625.95
Dry Wt. +tare:	393.34	480.79
Tare Wt:	160.27	140.47
Dry Wt.:	233.07	340.32
Water Wt.:	129.5	145.16
% moist.:	55.6	42.7

Specific Gravity:	2.60	Max Dry Density(pcf) =	68.7952	OMC =	55.5627065
		% of max =	100.0	+/- OMC =	0.00
Calculated % saturation:	81.52	Void ratio (e) =	1.36	Porosity (n) =	0.58

TEST READINGS

Z1(Mercury Height Difference @ t1):	5.1	cm	Hydraulic Gradient =	9.04
-------------------------------------	-----	----	----------------------	------

Date	elapsed t (seconds)	Z (pipet @ t)	$\Delta Z\pi$ (cm)	temp (deg C)	α (temp corr)	k (cm/sec)	k (ft./day)	Reset = *
8/26/2009	8	4.5	2.1553335	25	0.889	2.66E-05	7.55E-02	
8/26/2009	10	4.05	2.6053335	25	0.889	2.79E-05	7.91E-02	
8/26/2009	12	3.6	3.0553335	25	0.889	2.99E-05	8.48E-02	
8/26/2009	14	3.25	3.4053335	25	0.889	3.12E-05	8.84E-02	

SUMMARY

ka =	2.89E-05	cm/sec	Acceptance criteria =	25 %
ki			Vm	
k1 =	2.66E-05	cm/sec	7.8	%
k2 =	2.79E-05	cm/sec	3.5	%
k3 =	2.99E-05	cm/sec	3.5	%
k4 =	3.12E-05	cm/sec	7.8	%

Hydraulic conductivity	k =	2.89E-05	cm/sec	8.19E-02	ft/day
Void Ratio	e =	1.36			
Porosity	n =	0.58			
Bulk Density	γ =	1.71	g/cm ³	107.0	pcf
Water Content	W =	0.61	cm ³ /cm ³	(at 20 deg C)	
Intrinsic Permeability	kint =	2.96E-10	cm ²	(at 20 deg C)	

Liquid Limit LL		
Plastic Limit PL		
Plasticity Index PI		
- 200 Sieve		%
+ No 40 Sieve		%
+ No 4 Sieve		%

Respectfully Submitted

Robert M. Duke, P.E.



ETTL Engineers & Consultants Inc.

GEOTECHNICAL * MATERIALS * ENVIRONMENTAL * DRILLING * LANDFILLS

HYDRAULIC CONDUCTIVITY DETERMINATION FLEXIBLE WALL PERMEAMETER - CONSTANT VOLUME (Mercury Permometer Test)

Project : Martin Lake PDP 1 - 3 Supplemental, Tatum, Texas
 Date: 8/26/2009 Panel Number : P 2 ; ASTM D 5084
 Project No. : G 3219-09 Permemeter Data
 Boring No.: B - 14 ap = 0.031416 cm2 Set Mercury to Equilibrium 1.8 cm3
 Sample: aa = 0.767120 cm2 Diam Per at Pipet Rp 6.7 cm3
 Depth (ft): 16' to 17' M1 = 0.030180 C = 0.000414194 Annulus Ra 1.5 cm3
 Other Location: M2 = 1.040953 T = 0.203859738

Material Description : Dark Gray Ash

SAMPLE DATA

Wet Wt. sample + ring or tare :	<u>457.47</u> g		
Tare or ring Wt. :	<u>0.0</u> g		
Wet Wt. of Sample :	<u>457.47</u> g	Before Test	After Test
Diameter :	<u>2.85</u> in	Tare No.:	<u>T 18</u>
Length :	<u>2.80</u> in	Wet Wt.+tare:	<u>711.07</u>
Area :	<u>6.38</u> in ²	Dry Wt.+tare:	<u>478.92</u>
Volume :	<u>17.88</u> in ³	Tare Wt.:	<u>146.73</u>
Unit Wt.(wet):	<u>97.45</u> pcf	Dry Wt.:	<u>332.19</u>
Unit Wt.(dry):	<u>57.36</u> pcf	Water Wt.:	<u>232.15</u>
		% moist.:	<u>69.9</u>

Specific Gravity: 2.50 Max Dry Density(pcf) = 57.38916 OMC = 69.8847045
 % of max = 100.0 +/- OMC = 0.00
 Calculated % saturation: 87.92 Void ratio (e) = 1.72 Porosity (n) = 0.63

TEST READINGS

Z1(Mercury Height Difference @ t1): 5.1 cm Hydraulic Gradient = 9.04

Date	elapsed t (seconds)	Z (pipet @ t)	$\Delta Z\pi$ (cm)	temp (deg C)	α (temp corr)	k (cm/sec)	k (ft./day)	Reset = *
8/26/2009	80	4.2	2.4553335	25	0.889	3.20E-06	9.06E-03	
8/26/2009	90	4.05	2.6053335	25	0.889	3.10E-06	8.79E-03	
8/26/2009	100	3.9	2.7553335	25	0.889	3.04E-06	8.61E-03	
8/26/2009	110	3.75	2.9053335	25	0.889	3.00E-06	8.52E-03	

SUMMARY

ka = 3.08E-06 cm/sec Acceptance criteria = 25 %
 $\frac{k_i}{k_a}$
 k1 = 3.20E-06 cm/sec 3.6 % Vm = $\frac{k_a - k_i}{k_a} \times 100$
 k2 = 3.10E-06 cm/sec 0.5 %
 k3 = 3.04E-06 cm/sec 1.5 %
 k4 = 3.00E-06 cm/sec 2.6 %

Hydraulic conductivity	k =	<u>3.08E-06</u> cm/sec	<u>8.74E-03</u> ft/day
Void Ratio	e =	<u>1.72</u>	
Porosity	n =	<u>0.63</u>	
Bulk Density	γ =	<u>1.56</u> g/cm3	<u>97.5</u> pcf
Water Content	W =	<u>0.64</u> cm3/cm3	(at 20 deg C)
Intrinsic Permeability	kint =	<u>3.16E-11</u> cm2	(at 20 deg C)

Liquid Limit LL		
Plastic Limit PL		
Plasticity Index PI		
- 200 Sieve		%
+ No 40 Sieve		%
+ No 4 Sieve		%

Respectfully Submitted

Robert M. Duke, P.E.



ETTL Engineers & Consultants Inc.

GEOTECHNICAL * MATERIALS * ENVIRONMENTAL * DRILLING * LANDFILLS

HYDRAULIC CONDUCTIVITY DETERMINATION FLEXIBLE WALL PERMEAMETER - CONSTANT VOLUME (Mercury Permometer Test)

Project : Luminant Martin Lake Supplemental, TP-31, Tatum, Texas
 Date: 9/9/2009 Panel Number : P 1 ; ASTM D 5084
 Project No. : G 3219-09 Permometer Data

Boring No.:	TP- 31	ap =	0.031416 cm2	Set Mercury to Dinat Dn at	Equilibrium	1.8	cm3
Sample:	9228	aa =	0.767120 cm2		Pipet Rp	6.7	cm3
Depth (ft):	0' to 5'	M1 =	0.030180	C =	0.000414162 Annulus Ra	1.5	cm3
Other Location:		M2 =	1.040953	T =	0.203870442		

Material Description : Tan & Reddish Tan Silty Sand

SAMPLE DATA

Wet Wt. sample + ring or tare :	627.20	g					
Tare or ring Wt. :	0.0	g					
Wet Wt. of Sample :	627.20	g					
Diameter :	2.89	in	7.33	cm2	Before Test	Tare No.:	T 6
Length :	2.88	in	7.30	cm		Wet Wt. +tare:	841.20
Area:	6.55	in^2	42.23	cm2		Dry Wt. +tare:	749.54
Volume :	18.82	in^3	308.41	cm3		Tare Wt.:	217.39
Unit Wt. (wet):	126.90	pcf	2.03	g/cm^3		Dry Wt.:	532.15
Unit Wt. (dry):	108.26	pcf	1.73	g/cm^3		Water Wt.:	91.66
						% moist.:	17.2
							19.1

Specific Gravity: 2.65 Max Dry Density(pcf) = 108.3018 OMC = 17.2244668
 % of max = 100.0 +/- OMC = 0.00
 Calculated % saturation: 95.65 Void ratio (e) = 0.53 Porosity (n) = 0.35

TEST READINGS

Z1(Mercury Height Difference @ t1): 5.1 cm Hydraulic Gradient = 8.81

Date	elapsed t (seconds)	Z (pipet @ t)	$\Delta Z\pi$ (cm)	temp (deg C)	α (temp corr)	k (cm/sec)	k (ft./day)	Reset = *
7/31/2009	600	5.3	1.3550759	25	0.889	1.98E-07	5.63E-04	
7/31/2009	720	5.1	1.5550759	25	0.889	1.95E-07	5.53E-04	
7/31/2009	840	5	1.6550759	25	0.889	1.80E-07	5.12E-04	
7/31/2009	960	4.8	1.8550759	25	0.889	1.82E-07	5.17E-04	

SUMMARY

ka =	1.89E-07	cm/sec	Acceptance criteria =	25 %
ki			Vm	
k1 =	1.98E-07	cm/sec	5.0 %	Vm = $\frac{ ka-ki }{ka} \times 100$
k2 =	1.95E-07	cm/sec	3.2 %	
k3 =	1.80E-07	cm/sec	4.5 %	
k4 =	1.82E-07	cm/sec	3.6 %	

Hydraulic conductivity	k =	1.89E-07	cm/sec	5.36E-04	ft/day
Void Ratio	e =	0.53			
Porosity	n =	0.35			
Bulk Density	γ =	2.03	g/cm3	126.9	pcf
Water Content	W =	0.30	cm3/cm3	(at 20 deg C)	
Intrinsic Permeability	kint =	1.94E-12	cm2	(at 20 deg C)	

Liquid Limit LL	20
Plastic Limit PL	17
Plasticity Index PI	3
- 200 Sieve	27 %
+ No 40 Sieve	2 %
+ No 4 Sieve	1 %

Respectfully Submitted

Robert M. Duke, P.E.

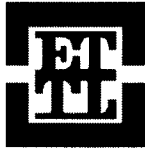

ETTL Engineers & Consultants Inc.

GEOTECHNICAL * MATERIALS * ENVIRONMENTAL * DRILLING * LANDFILLS

Project: Luminant Martin Lake Supplemental, Tatum, Texas
 Client: HDR
 Contractor: _____
 Job No. G 3219 - 09

Sample No.: 9228 Date Sampled: 8/26/2009
 Material Origin: TP- 31
 Sampling Info. provided By: Jacob LeNoir
 Location Sampled: TP- 31
 Material Description: Tan & Reddish Tan Silty Sand
 Sampled By: Jacob LeNoir
 Technician: T. Sliger Date: 8/28/2009

Maximum Dry Density: (ASTM D 698)	115.9	(lb/ft ³)
Optimum Moisture Content:	13.2	(%)

Classification

LL	20
PL	17
PI	3

-200 Sieve	27%
+40 Sieve	2%
+4 Sieve	1%

Proctor Points	
% Moisture	Dry Density (lb/ft ³)
9.6%	111.1
11.9%	114.9
14.3%	115.1
16.3%	110.9
18.6%	105.7

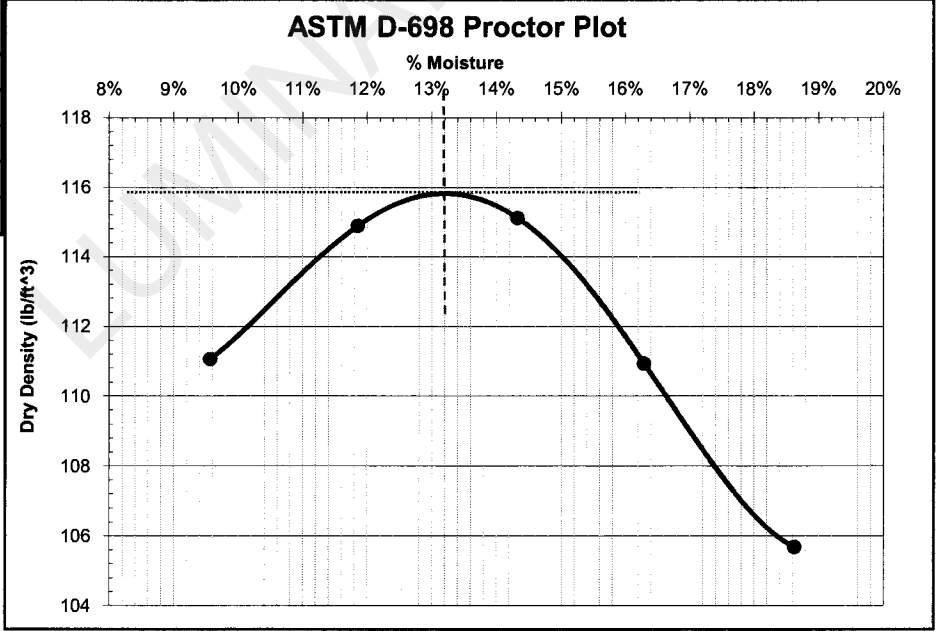

Respectfully Submitted

Robert M. Duke, P.E.

210 Beech Street
 Texarkana, AR 71854
 870-772-0013 Phone
 870-216-2413 Fax

1717 East Erwin
 Tyler, Texas 75702
 903-595-4421 Phone
 903-595-6113 Fax
 www.ettlinc.com

707 West Cotton Street
 Longview, Texas 75604-5505
 903-758-0915 Phone
 903-758-8245 Fax

APPENDIX C
CPT-BASED LIQUEFACTION POTENTIAL ANALYSIS

LUMINANT

TABLE OF CONTENTS

B-02 results	
Summary data report	1
Liquefaction potential index data	2
B-07 results	
Summary data report	7
Liquefaction potential index data	8
B-12 results	
Summary data report	15
Liquefaction potential index data	16

LUMINANT

LIQUEFACTION ANALYSIS REPORT

Project title : Martin Lake

Location : PDP-5

CPT file : B-02

Input parameters and analysis data

Analysis method:	Robertson (2009)	G.W.T. (in-situ):	1.00 ft	Use fill:	No	Clay like behavior	
Fines correction method:	Robertson (2009)	G.W.T. (earthq.):	0.00 ft	Fill height:	N/A	applied:	All soils
Points to test:	Based on Ic value	Average results interval:	3	Fill weight:	N/A	Limit depth applied:	No
Earthquake magnitude M_w :	6.20	Ic cut-off value:	2.60	Trans. detect. applied:	No	Limit depth:	N/A
Peak ground acceleration:	0.09	Unit weight calculation:	Based on SBT	K_0 applied:	Yes	MSF method:	Method based

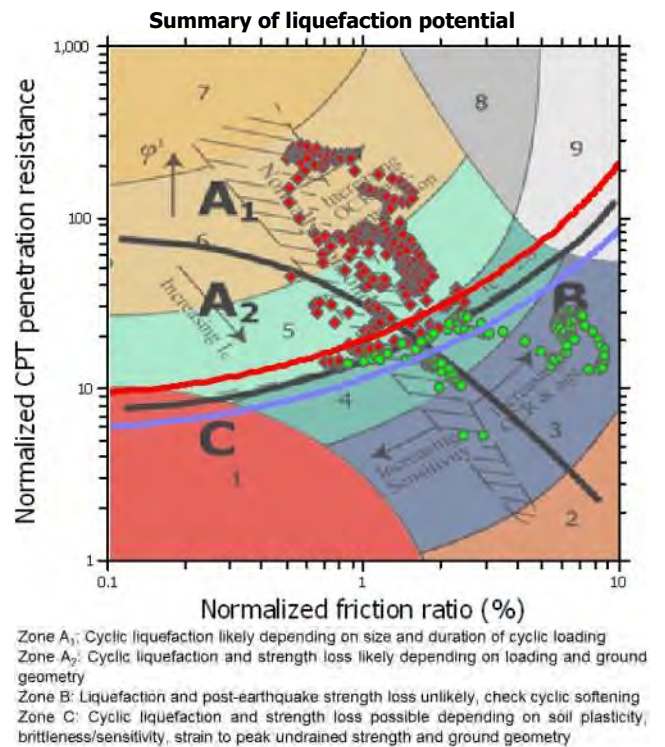
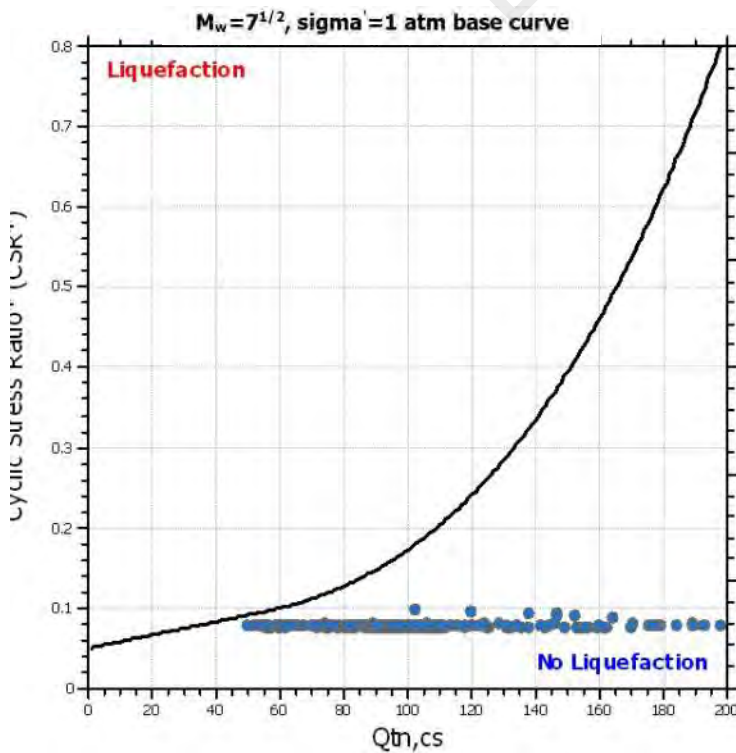
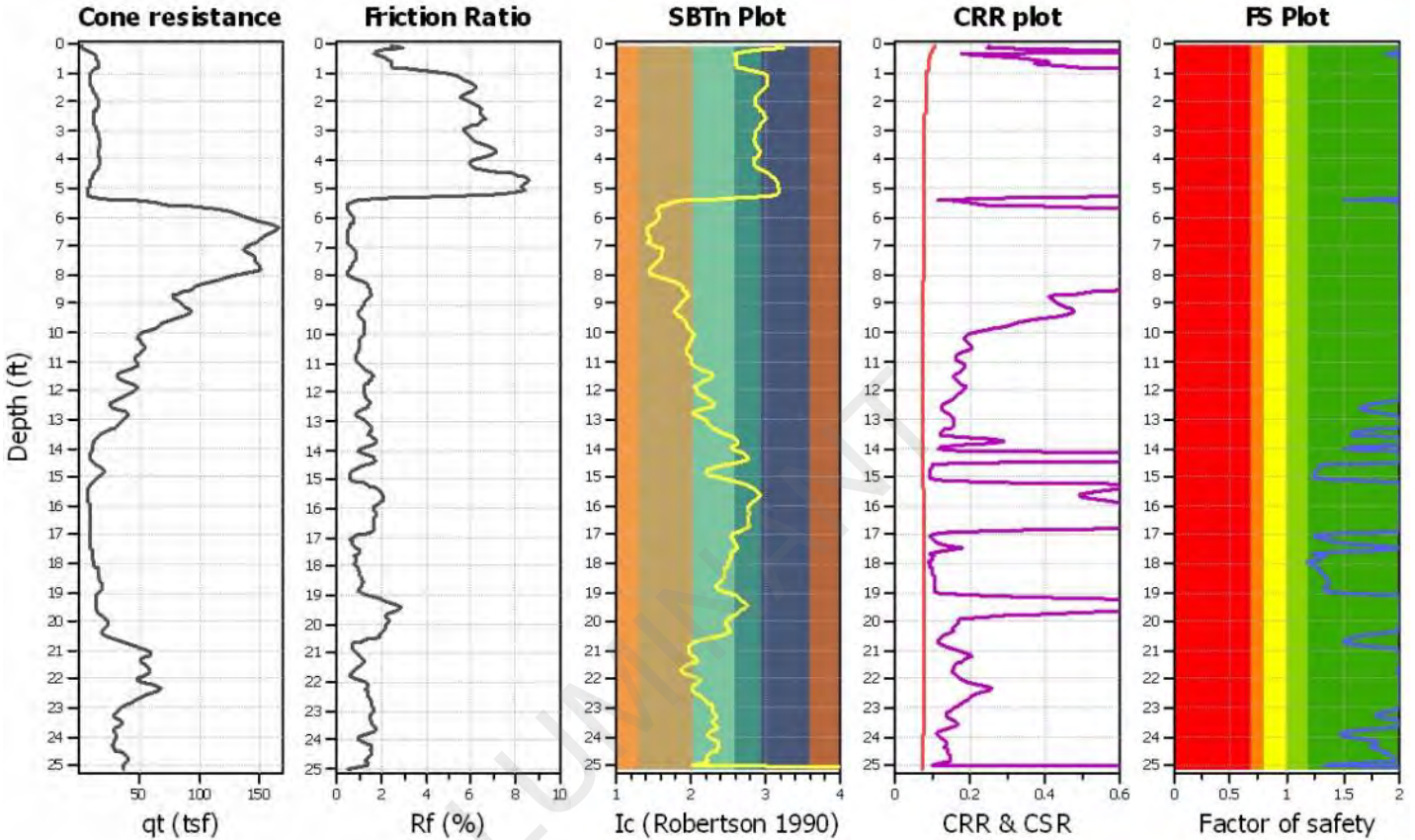

:: Liquefaction Potential Index calculation data ::											
Depth (ft)	FS	F_L	w_z	d_z	LPI	Depth (ft)	FS	F_L	w_z	d_z	LPI
0.07	2.00	0.00	9.99	0.06	0.00	0.13	2.00	0.00	9.98	0.06	0.00
0.20	2.00	0.00	9.97	0.07	0.00	0.26	2.00	0.00	9.96	0.06	0.00
0.33	1.88	0.00	9.95	0.07	0.00	0.39	2.00	0.00	9.94	0.06	0.00
0.46	2.00	0.00	9.93	0.07	0.00	0.52	2.00	0.00	9.92	0.06	0.00
0.59	2.00	0.00	9.91	0.07	0.00	0.66	2.00	0.00	9.90	0.07	0.00
0.72	2.00	0.00	9.89	0.06	0.00	0.79	2.00	0.00	9.88	0.07	0.00
0.85	2.00	0.00	9.87	0.06	0.00	0.92	2.00	0.00	9.86	0.07	0.00
0.98	2.00	0.00	9.85	0.06	0.00	1.05	2.00	0.00	9.84	0.07	0.00
1.12	2.00	0.00	9.83	0.07	0.00	1.18	2.00	0.00	9.82	0.06	0.00
1.25	2.00	0.00	9.81	0.07	0.00	1.31	2.00	0.00	9.80	0.06	0.00
1.38	2.00	0.00	9.79	0.07	0.00	1.44	2.00	0.00	9.78	0.06	0.00
1.51	2.00	0.00	9.77	0.07	0.00	1.57	2.00	0.00	9.76	0.06	0.00
1.64	2.00	0.00	9.75	0.07	0.00	1.71	2.00	0.00	9.74	0.07	0.00
1.77	2.00	0.00	9.73	0.06	0.00	1.84	2.00	0.00	9.72	0.07	0.00
1.90	2.00	0.00	9.71	0.06	0.00	1.97	2.00	0.00	9.70	0.07	0.00
2.03	2.00	0.00	9.69	0.06	0.00	2.10	2.00	0.00	9.68	0.07	0.00
2.16	2.00	0.00	9.67	0.06	0.00	2.23	2.00	0.00	9.66	0.07	0.00
2.30	2.00	0.00	9.65	0.07	0.00	2.36	2.00	0.00	9.64	0.06	0.00
2.43	2.00	0.00	9.63	0.07	0.00	2.49	2.00	0.00	9.62	0.06	0.00
2.56	2.00	0.00	9.61	0.07	0.00	2.62	2.00	0.00	9.60	0.06	0.00
2.69	2.00	0.00	9.59	0.07	0.00	2.76	2.00	0.00	9.58	0.07	0.00
2.82	2.00	0.00	9.57	0.06	0.00	2.89	2.00	0.00	9.56	0.07	0.00
2.95	2.00	0.00	9.55	0.06	0.00	3.02	2.00	0.00	9.54	0.07	0.00
3.08	2.00	0.00	9.53	0.06	0.00	3.15	2.00	0.00	9.52	0.07	0.00
3.21	2.00	0.00	9.51	0.06	0.00	3.28	2.00	0.00	9.50	0.07	0.00
3.35	2.00	0.00	9.49	0.07	0.00	3.41	2.00	0.00	9.48	0.06	0.00
3.48	2.00	0.00	9.47	0.07	0.00	3.54	2.00	0.00	9.46	0.06	0.00
3.61	2.00	0.00	9.45	0.07	0.00	3.67	2.00	0.00	9.44	0.06	0.00
3.74	2.00	0.00	9.43	0.07	0.00	3.80	2.00	0.00	9.42	0.06	0.00
3.87	2.00	0.00	9.41	0.07	0.00	3.94	2.00	0.00	9.40	0.07	0.00
4.00	2.00	0.00	9.39	0.06	0.00	4.07	2.00	0.00	9.38	0.07	0.00
4.13	2.00	0.00	9.37	0.06	0.00	4.20	2.00	0.00	9.36	0.07	0.00
4.26	2.00	0.00	9.35	0.06	0.00	4.33	2.00	0.00	9.34	0.07	0.00
4.40	2.00	0.00	9.33	0.07	0.00	4.46	2.00	0.00	9.32	0.06	0.00
4.53	2.00	0.00	9.31	0.07	0.00	4.59	2.00	0.00	9.30	0.06	0.00
4.66	2.00	0.00	9.29	0.07	0.00	4.72	2.00	0.00	9.28	0.06	0.00
4.79	2.00	0.00	9.27	0.07	0.00	4.85	2.00	0.00	9.26	0.06	0.00
4.92	2.00	0.00	9.25	0.07	0.00	4.99	2.00	0.00	9.24	0.07	0.00
5.05	2.00	0.00	9.23	0.06	0.00	5.12	2.00	0.00	9.22	0.07	0.00
5.18	2.00	0.00	9.21	0.06	0.00	5.25	2.00	0.00	9.20	0.07	0.00
5.31	2.00	0.00	9.19	0.06	0.00	5.38	1.50	0.00	9.18	0.07	0.00
5.44	1.85	0.00	9.17	0.06	0.00	5.51	2.00	0.00	9.16	0.07	0.00
5.58	2.00	0.00	9.15	0.07	0.00	5.64	2.00	0.00	9.14	0.06	0.00
5.71	2.00	0.00	9.13	0.07	0.00	5.77	2.00	0.00	9.12	0.06	0.00
5.84	2.00	0.00	9.11	0.07	0.00	5.90	2.00	0.00	9.10	0.06	0.00
5.97	2.00	0.00	9.09	0.07	0.00	6.04	2.00	0.00	9.08	0.07	0.00
6.10	2.00	0.00	9.07	0.06	0.00	6.17	2.00	0.00	9.06	0.07	0.00
6.23	2.00	0.00	9.05	0.06	0.00	6.30	2.00	0.00	9.04	0.07	0.00

:: Liquefaction Potential Index calculation data :: (continued)											
Depth (ft)	FS	F_L	w_z	d_z	LPI	Depth (ft)	FS	F_L	w_z	d_z	LPI
6.36	2.00	0.00	9.03	0.06	0.00	6.43	2.00	0.00	9.02	0.07	0.00
6.49	2.00	0.00	9.01	0.06	0.00	6.56	2.00	0.00	9.00	0.07	0.00
6.63	2.00	0.00	8.99	0.07	0.00	6.69	2.00	0.00	8.98	0.06	0.00
6.76	2.00	0.00	8.97	0.07	0.00	6.82	2.00	0.00	8.96	0.06	0.00
6.89	2.00	0.00	8.95	0.07	0.00	6.95	2.00	0.00	8.94	0.06	0.00
7.02	2.00	0.00	8.93	0.07	0.00	7.08	2.00	0.00	8.92	0.06	0.00
7.15	2.00	0.00	8.91	0.07	0.00	7.22	2.00	0.00	8.90	0.07	0.00
7.28	2.00	0.00	8.89	0.06	0.00	7.35	2.00	0.00	8.88	0.07	0.00
7.41	2.00	0.00	8.87	0.06	0.00	7.48	2.00	0.00	8.86	0.07	0.00
7.54	2.00	0.00	8.85	0.06	0.00	7.61	2.00	0.00	8.84	0.07	0.00
7.68	2.00	0.00	8.83	0.07	0.00	7.74	2.00	0.00	8.82	0.06	0.00
7.81	2.00	0.00	8.81	0.07	0.00	7.87	2.00	0.00	8.80	0.06	0.00
7.94	2.00	0.00	8.79	0.07	0.00	8.00	2.00	0.00	8.78	0.06	0.00
8.07	2.00	0.00	8.77	0.07	0.00	8.13	2.00	0.00	8.76	0.06	0.00
8.20	2.00	0.00	8.75	0.07	0.00	8.27	2.00	0.00	8.74	0.07	0.00
8.33	2.00	0.00	8.73	0.06	0.00	8.40	2.00	0.00	8.72	0.07	0.00
8.46	2.00	0.00	8.71	0.06	0.00	8.53	2.00	0.00	8.70	0.07	0.00
8.59	2.00	0.00	8.69	0.06	0.00	8.66	2.00	0.00	8.68	0.07	0.00
8.72	2.00	0.00	8.67	0.06	0.00	8.79	2.00	0.00	8.66	0.07	0.00
8.86	2.00	0.00	8.65	0.07	0.00	8.92	2.00	0.00	8.64	0.06	0.00
8.99	2.00	0.00	8.63	0.07	0.00	9.05	2.00	0.00	8.62	0.06	0.00
9.12	2.00	0.00	8.61	0.07	0.00	9.18	2.00	0.00	8.60	0.06	0.00
9.25	2.00	0.00	8.59	0.07	0.00	9.32	2.00	0.00	8.58	0.07	0.00
9.38	2.00	0.00	8.57	0.06	0.00	9.45	2.00	0.00	8.56	0.07	0.00
9.51	2.00	0.00	8.55	0.06	0.00	9.58	2.00	0.00	8.54	0.07	0.00
9.64	2.00	0.00	8.53	0.06	0.00	9.71	2.00	0.00	8.52	0.07	0.00
9.77	2.00	0.00	8.51	0.06	0.00	9.84	2.00	0.00	8.50	0.07	0.00
9.91	2.00	0.00	8.49	0.07	0.00	9.97	2.00	0.00	8.48	0.06	0.00
10.04	2.00	0.00	8.47	0.07	0.00	10.10	2.00	0.00	8.46	0.06	0.00
10.17	2.00	0.00	8.45	0.07	0.00	10.23	2.00	0.00	8.44	0.06	0.00
10.30	2.00	0.00	8.43	0.07	0.00	10.36	2.00	0.00	8.42	0.06	0.00
10.43	2.00	0.00	8.41	0.07	0.00	10.50	2.00	0.00	8.40	0.07	0.00
10.56	2.00	0.00	8.39	0.06	0.00	10.63	2.00	0.00	8.38	0.07	0.00
10.69	2.00	0.00	8.37	0.06	0.00	10.76	2.00	0.00	8.36	0.07	0.00
10.82	2.00	0.00	8.35	0.06	0.00	10.89	2.00	0.00	8.34	0.07	0.00
10.96	2.00	0.00	8.33	0.07	0.00	11.02	2.00	0.00	8.32	0.06	0.00
11.09	2.00	0.00	8.31	0.07	0.00	11.15	2.00	0.00	8.30	0.06	0.00
11.22	2.00	0.00	8.29	0.07	0.00	11.28	2.00	0.00	8.28	0.06	0.00
11.35	2.00	0.00	8.27	0.07	0.00	11.41	2.00	0.00	8.26	0.06	0.00
11.48	2.00	0.00	8.25	0.07	0.00	11.55	2.00	0.00	8.24	0.07	0.00
11.61	2.00	0.00	8.23	0.06	0.00	11.68	2.00	0.00	8.22	0.07	0.00
11.74	2.00	0.00	8.21	0.06	0.00	11.81	2.00	0.00	8.20	0.07	0.00
11.87	2.00	0.00	8.19	0.06	0.00	11.94	2.00	0.00	8.18	0.07	0.00
12.00	2.00	0.00	8.17	0.06	0.00	12.07	2.00	0.00	8.16	0.07	0.00
12.14	2.00	0.00	8.15	0.07	0.00	12.20	2.00	0.00	8.14	0.06	0.00
12.27	2.00	0.00	8.13	0.07	0.00	12.33	2.00	0.00	8.12	0.06	0.00
12.40	1.89	0.00	8.11	0.07	0.00	12.46	1.78	0.00	8.10	0.06	0.00
12.53	1.71	0.00	8.09	0.07	0.00	12.60	1.65	0.00	8.08	0.07	0.00

:: Liquefaction Potential Index calculation data :: (continued)											
Depth (ft)	FS	F_L	w_z	d_z	LPI	Depth (ft)	FS	F_L	w_z	d_z	LPI
12.66	1.66	0.00	8.07	0.06	0.00	12.73	1.76	0.00	8.06	0.07	0.00
12.79	1.87	0.00	8.05	0.06	0.00	12.86	1.97	0.00	8.04	0.07	0.00
12.92	2.00	0.00	8.03	0.06	0.00	12.99	2.00	0.00	8.02	0.07	0.00
13.05	2.00	0.00	8.01	0.06	0.00	13.12	2.00	0.00	8.00	0.07	0.00
13.19	2.00	0.00	7.99	0.07	0.00	13.25	2.00	0.00	7.98	0.06	0.00
13.32	1.93	0.00	7.97	0.07	0.00	13.38	1.78	0.00	7.96	0.06	0.00
13.45	1.65	0.00	7.95	0.07	0.00	13.51	1.59	0.00	7.94	0.06	0.00
13.58	1.57	0.00	7.93	0.07	0.00	13.64	2.00	0.00	7.92	0.06	0.00
13.71	2.00	0.00	7.91	0.07	0.00	13.78	2.00	0.00	7.90	0.07	0.00
13.84	2.00	0.00	7.89	0.06	0.00	13.91	2.00	0.00	7.88	0.07	0.00
13.97	1.58	0.00	7.87	0.06	0.00	14.04	1.52	0.00	7.86	0.07	0.00
14.10	2.00	0.00	7.85	0.06	0.00	14.17	2.00	0.00	7.84	0.07	0.00
14.24	2.00	0.00	7.83	0.07	0.00	14.30	2.00	0.00	7.82	0.06	0.00
14.37	2.00	0.00	7.81	0.07	0.00	14.43	2.00	0.00	7.80	0.06	0.00
14.50	2.00	0.00	7.79	0.07	0.00	14.56	1.31	0.00	7.78	0.06	0.00
14.63	1.29	0.00	7.77	0.07	0.00	14.69	1.27	0.00	7.76	0.06	0.00
14.76	1.26	0.00	7.75	0.07	0.00	14.83	1.25	0.00	7.74	0.07	0.00
14.89	1.24	0.00	7.73	0.06	0.00	14.96	1.22	0.00	7.72	0.07	0.00
15.02	1.23	0.00	7.71	0.06	0.00	15.09	1.26	0.00	7.70	0.07	0.00
15.15	1.73	0.00	7.69	0.06	0.00	15.22	2.00	0.00	7.68	0.07	0.00
15.28	2.00	0.00	7.67	0.06	0.00	15.35	2.00	0.00	7.66	0.07	0.00
15.42	2.00	0.00	7.65	0.07	0.00	15.48	2.00	0.00	7.64	0.06	0.00
15.55	2.00	0.00	7.63	0.07	0.00	15.61	2.00	0.00	7.62	0.06	0.00
15.68	2.00	0.00	7.61	0.07	0.00	15.74	2.00	0.00	7.60	0.06	0.00
15.81	2.00	0.00	7.59	0.07	0.00	15.88	2.00	0.00	7.58	0.07	0.00
15.94	2.00	0.00	7.57	0.06	0.00	16.01	2.00	0.00	7.56	0.07	0.00
16.07	2.00	0.00	7.55	0.06	0.00	16.14	2.00	0.00	7.54	0.07	0.00
16.20	2.00	0.00	7.53	0.06	0.00	16.27	2.00	0.00	7.52	0.07	0.00
16.33	2.00	0.00	7.51	0.06	0.00	16.40	2.00	0.00	7.50	0.07	0.00
16.47	2.00	0.00	7.49	0.07	0.00	16.53	2.00	0.00	7.48	0.06	0.00
16.60	2.00	0.00	7.47	0.07	0.00	16.66	2.00	0.00	7.46	0.06	0.00
16.73	2.00	0.00	7.45	0.07	0.00	16.79	2.00	0.00	7.44	0.06	0.00
16.86	2.00	0.00	7.43	0.07	0.00	16.92	1.96	0.00	7.42	0.06	0.00
16.99	1.33	0.00	7.41	0.07	0.00	17.06	1.24	0.00	7.40	0.07	0.00
17.12	1.29	0.00	7.39	0.06	0.00	17.19	1.38	0.00	7.38	0.07	0.00
17.25	1.40	0.00	7.37	0.06	0.00	17.32	1.56	0.00	7.36	0.07	0.00
17.38	1.82	0.00	7.35	0.06	0.00	17.45	2.00	0.00	7.34	0.07	0.00
17.52	1.88	0.00	7.33	0.07	0.00	17.58	1.48	0.00	7.32	0.06	0.00
17.65	1.23	0.00	7.31	0.07	0.00	17.71	1.33	0.00	7.30	0.06	0.00
17.78	1.29	0.00	7.29	0.07	0.00	17.84	1.29	0.00	7.28	0.06	0.00
17.91	1.18	0.00	7.27	0.07	0.00	17.97	1.23	0.00	7.26	0.06	0.00
18.04	1.23	0.00	7.25	0.07	0.00	18.11	1.25	0.00	7.24	0.07	0.00
18.17	1.27	0.00	7.23	0.06	0.00	18.24	1.29	0.00	7.22	0.07	0.00
18.30	1.30	0.00	7.21	0.06	0.00	18.37	1.31	0.00	7.20	0.07	0.00
18.43	1.34	0.00	7.19	0.06	0.00	18.50	1.36	0.00	7.18	0.07	0.00
18.56	1.36	0.00	7.17	0.06	0.00	18.63	1.36	0.00	7.16	0.07	0.00
18.70	1.37	0.00	7.15	0.07	0.00	18.76	1.36	0.00	7.14	0.06	0.00
18.83	1.34	0.00	7.13	0.07	0.00	18.89	1.34	0.00	7.12	0.06	0.00

:: Liquefaction Potential Index calculation data :: (continued)											
Depth (ft)	FS	F _L	w _z	d _z	LPI	Depth (ft)	FS	F _L	w _z	d _z	LPI
18.96	1.35	0.00	7.11	0.07	0.00	19.02	1.52	0.00	7.10	0.06	0.00
19.09	2.00	0.00	7.09	0.07	0.00	19.16	2.00	0.00	7.08	0.07	0.00
19.22	2.00	0.00	7.07	0.06	0.00	19.29	2.00	0.00	7.06	0.07	0.00
19.35	2.00	0.00	7.05	0.06	0.00	19.42	2.00	0.00	7.04	0.07	0.00
19.48	2.00	0.00	7.03	0.06	0.00	19.55	2.00	0.00	7.02	0.07	0.00
19.61	2.00	0.00	7.01	0.06	0.00	19.68	2.00	0.00	7.00	0.07	0.00
19.75	2.00	0.00	6.99	0.07	0.00	19.81	2.00	0.00	6.98	0.06	0.00
19.88	2.00	0.00	6.97	0.07	0.00	19.94	2.00	0.00	6.96	0.06	0.00
20.01	2.00	0.00	6.95	0.07	0.00	20.07	2.00	0.00	6.94	0.06	0.00
20.14	2.00	0.00	6.93	0.07	0.00	20.20	2.00	0.00	6.92	0.06	0.00
20.27	1.99	0.00	6.91	0.07	0.00	20.34	2.00	0.00	6.90	0.07	0.00
20.40	1.90	0.00	6.89	0.06	0.00	20.47	1.69	0.00	6.88	0.07	0.00
20.53	1.62	0.00	6.87	0.06	0.00	20.60	1.54	0.00	6.86	0.07	0.00
20.66	1.50	0.00	6.85	0.06	0.00	20.73	1.52	0.00	6.84	0.07	0.00
20.80	1.62	0.00	6.83	0.07	0.00	20.86	1.77	0.00	6.82	0.06	0.00
20.93	1.97	0.00	6.81	0.07	0.00	20.99	2.00	0.00	6.80	0.06	0.00
21.06	2.00	0.00	6.79	0.07	0.00	21.12	2.00	0.00	6.78	0.06	0.00
21.19	2.00	0.00	6.77	0.07	0.00	21.25	2.00	0.00	6.76	0.06	0.00
21.32	2.00	0.00	6.75	0.07	0.00	21.39	2.00	0.00	6.74	0.07	0.00
21.45	2.00	0.00	6.73	0.06	0.00	21.52	2.00	0.00	6.72	0.07	0.00
21.58	2.00	0.00	6.71	0.06	0.00	21.65	2.00	0.00	6.70	0.07	0.00
21.71	1.99	0.00	6.69	0.06	0.00	21.78	1.99	0.00	6.68	0.07	0.00
21.84	2.00	0.00	6.67	0.06	0.00	21.91	2.00	0.00	6.66	0.07	0.00
21.98	2.00	0.00	6.65	0.07	0.00	22.04	2.00	0.00	6.64	0.06	0.00
22.11	2.00	0.00	6.63	0.07	0.00	22.17	2.00	0.00	6.62	0.06	0.00
22.24	2.00	0.00	6.61	0.07	0.00	22.30	2.00	0.00	6.60	0.06	0.00
22.37	2.00	0.00	6.59	0.07	0.00	22.44	2.00	0.00	6.58	0.07	0.00
22.50	2.00	0.00	6.57	0.06	0.00	22.57	2.00	0.00	6.56	0.07	0.00
22.63	2.00	0.00	6.55	0.06	0.00	22.70	2.00	0.00	6.54	0.07	0.00
22.76	2.00	0.00	6.53	0.06	0.00	22.83	2.00	0.00	6.52	0.07	0.00
22.89	2.00	0.00	6.51	0.06	0.00	22.96	2.00	0.00	6.50	0.07	0.00
23.03	2.00	0.00	6.49	0.07	0.00	23.09	1.96	0.00	6.48	0.06	0.00
23.16	1.86	0.00	6.47	0.07	0.00	23.22	1.81	0.00	6.46	0.06	0.00
23.29	1.78	0.00	6.45	0.07	0.00	23.35	1.86	0.00	6.44	0.06	0.00
23.42	1.98	0.00	6.43	0.07	0.00	23.48	2.00	0.00	6.42	0.06	0.00
23.55	2.00	0.00	6.41	0.07	0.00	23.62	2.00	0.00	6.40	0.07	0.00
23.68	1.93	0.00	6.39	0.06	0.00	23.75	1.69	0.00	6.38	0.07	0.00
23.81	1.53	0.00	6.37	0.06	0.00	23.88	1.47	0.00	6.36	0.07	0.00
23.94	1.49	0.00	6.35	0.06	0.00	24.01	1.58	0.00	6.34	0.07	0.00
24.08	1.70	0.00	6.33	0.07	0.00	24.14	1.81	0.00	6.32	0.06	0.00
24.21	1.80	0.00	6.31	0.07	0.00	24.27	1.77	0.00	6.30	0.06	0.00
24.34	1.73	0.00	6.29	0.07	0.00	24.40	1.80	0.00	6.28	0.06	0.00
24.47	1.84	0.00	6.27	0.07	0.00	24.53	1.87	0.00	6.26	0.06	0.00
24.60	1.89	0.00	6.25	0.07	0.00	24.67	1.90	0.00	6.24	0.07	0.00
24.73	1.93	0.00	6.23	0.06	0.00	24.80	1.96	0.00	6.22	0.07	0.00
24.86	1.96	0.00	6.21	0.06	0.00	24.93	1.61	0.00	6.20	0.07	0.00
24.99	1.34	0.00	6.19	0.06	0.00	25.06	2.00	0.00	6.18	0.07	0.00
25.12	2.00	0.00	6.17	0.06	0.00						

:: Liquefaction Potential Index calculation data :: (continued)											
Depth (ft)	FS	F_L	w_z	d_z	LPI	Depth (ft)	FS	F_L	w_z	d_z	LPI

Overall liquefaction potential: 0.00

LPI = 0.00 - Liquefaction risk very low
 LPI between 0.00 and 5.00 - Liquefaction risk low
 LPI between 5.00 and 15.00 - Liquefaction risk high
 LPI > 15.00 - Liquefaction risk very high

Abbreviations

- FS: Calculated factor of safety for test point
- F_L : 1 - FS
- w_z : Function value of the extend of soil liquefaction according to depth
- d_z : Layer thickness (ft)
- LPI: Liquefaction potential index value for test point



LIQUEFACTION ANALYSIS REPORT

Project title : Martin Lake

Location : PDP-5

CPT file : B-07

Input parameters and analysis data

Analysis method:	Robertson (2009)	G.W.T. (in-situ):	1.00 ft	Use fill:	No	Clay like behavior	
Fines correction method:	Robertson (2009)	G.W.T. (earthq.):	0.00 ft	Fill height:	N/A	applied:	All soils
Points to test:	Based on Ic value	Average results interval:	3	Fill weight:	N/A	Limit depth applied:	No
Earthquake magnitude M_w :	6.20	Ic cut-off value:	2.60	Trans. detect. applied:	No	Limit depth:	N/A
Peak ground acceleration:	0.09	Unit weight calculation:	Based on SBT	K_0 applied:	Yes	MSF method:	Method based

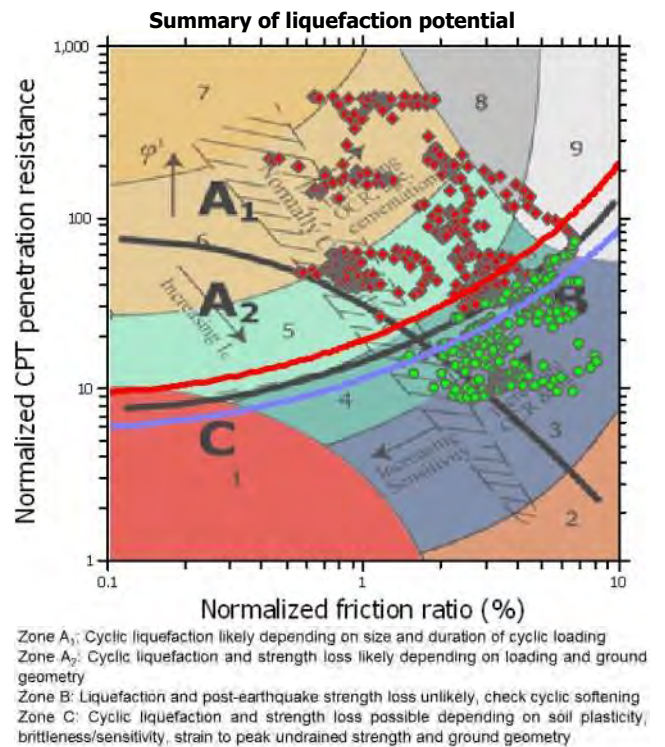
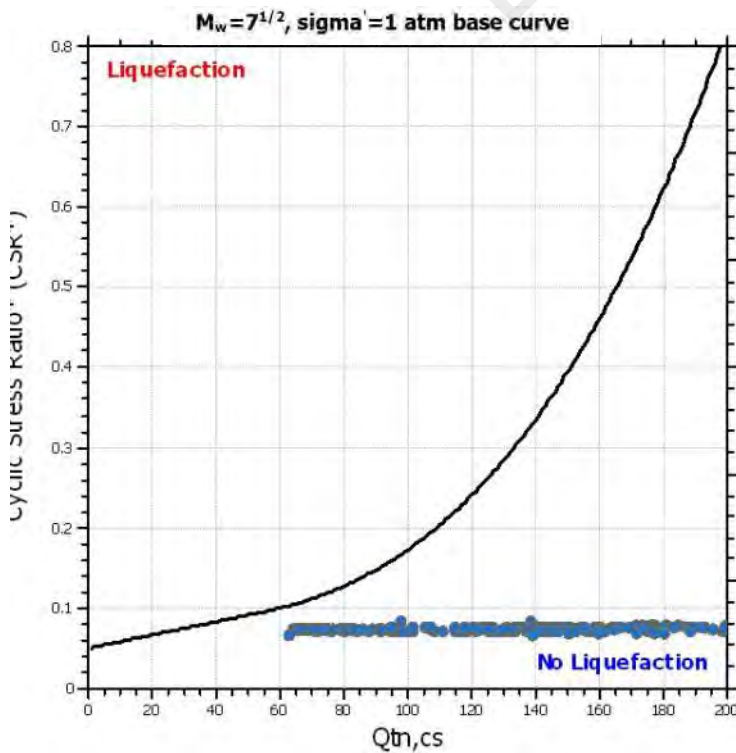
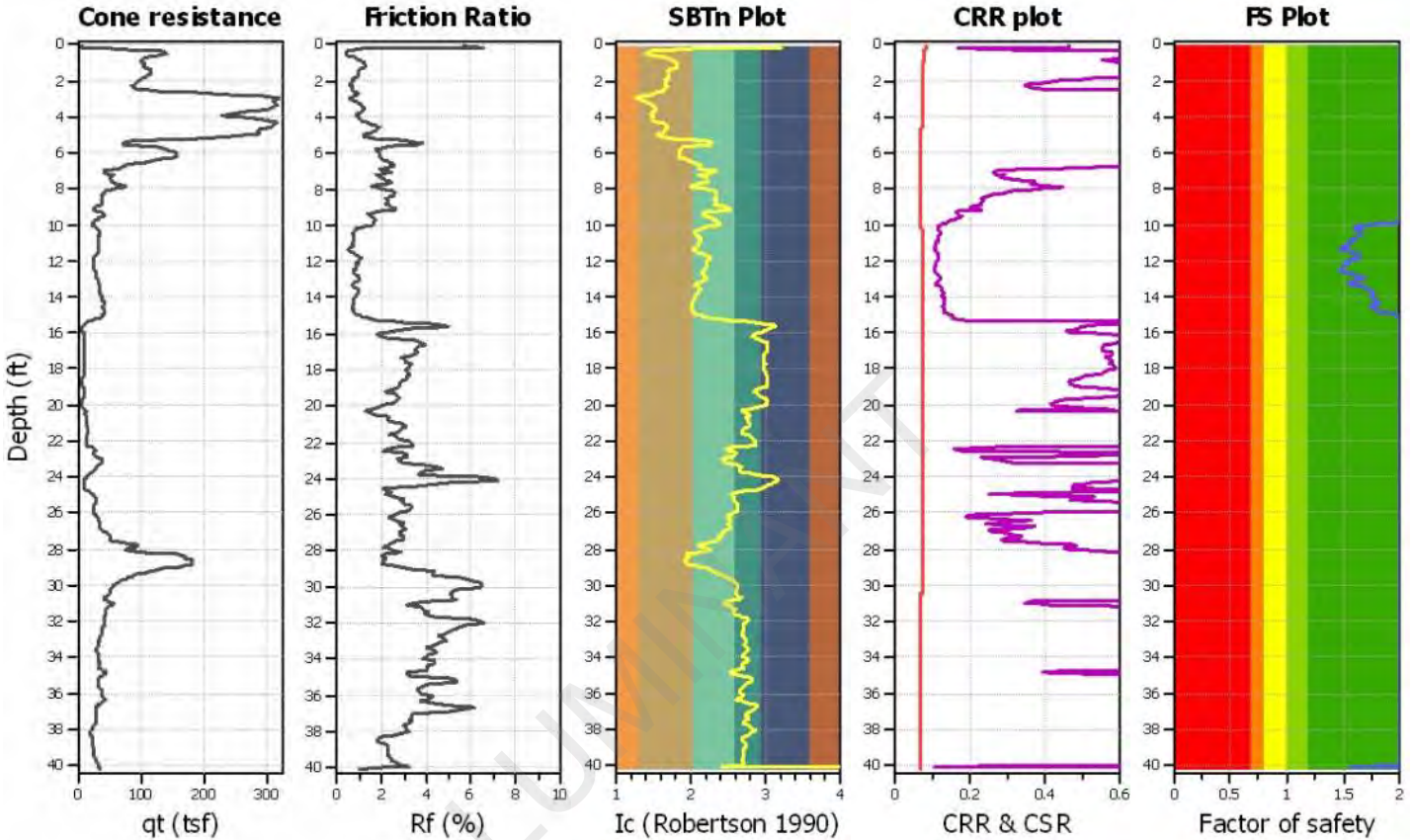

:: Liquefaction Potential Index calculation data ::											
Depth (ft)	FS	F_L	w_z	d_z	LPI	Depth (ft)	FS	F_L	w_z	d_z	LPI
0.07	2.00	0.00	9.99	0.06	0.00	0.13	2.00	0.00	9.98	0.06	0.00
0.20	2.00	0.00	9.97	0.07	0.00	0.26	2.00	0.00	9.96	0.06	0.00
0.33	2.00	0.00	9.95	0.07	0.00	0.39	2.00	0.00	9.94	0.06	0.00
0.46	2.00	0.00	9.93	0.07	0.00	0.52	2.00	0.00	9.92	0.06	0.00
0.59	2.00	0.00	9.91	0.07	0.00	0.66	2.00	0.00	9.90	0.07	0.00
0.72	2.00	0.00	9.89	0.06	0.00	0.79	2.00	0.00	9.88	0.07	0.00
0.85	2.00	0.00	9.87	0.06	0.00	0.92	2.00	0.00	9.86	0.07	0.00
0.98	2.00	0.00	9.85	0.06	0.00	1.05	2.00	0.00	9.84	0.07	0.00
1.12	2.00	0.00	9.83	0.07	0.00	1.18	2.00	0.00	9.82	0.06	0.00
1.25	2.00	0.00	9.81	0.07	0.00	1.31	2.00	0.00	9.80	0.06	0.00
1.38	2.00	0.00	9.79	0.07	0.00	1.44	2.00	0.00	9.78	0.06	0.00
1.51	2.00	0.00	9.77	0.07	0.00	1.57	2.00	0.00	9.76	0.06	0.00
1.64	2.00	0.00	9.75	0.07	0.00	1.71	2.00	0.00	9.74	0.07	0.00
1.77	2.00	0.00	9.73	0.06	0.00	1.84	2.00	0.00	9.72	0.07	0.00
1.90	2.00	0.00	9.71	0.06	0.00	1.97	2.00	0.00	9.70	0.07	0.00
2.03	2.00	0.00	9.69	0.06	0.00	2.10	2.00	0.00	9.68	0.07	0.00
2.16	2.00	0.00	9.67	0.06	0.00	2.23	2.00	0.00	9.66	0.07	0.00
2.30	2.00	0.00	9.65	0.07	0.00	2.36	2.00	0.00	9.64	0.06	0.00
2.43	2.00	0.00	9.63	0.07	0.00	2.49	2.00	0.00	9.62	0.06	0.00
2.56	2.00	0.00	9.61	0.07	0.00	2.62	2.00	0.00	9.60	0.06	0.00
2.69	2.00	0.00	9.59	0.07	0.00	2.76	2.00	0.00	9.58	0.07	0.00
2.82	2.00	0.00	9.57	0.06	0.00	2.89	2.00	0.00	9.56	0.07	0.00
2.95	2.00	0.00	9.55	0.06	0.00	3.02	2.00	0.00	9.54	0.07	0.00
3.08	2.00	0.00	9.53	0.06	0.00	3.15	2.00	0.00	9.52	0.07	0.00
3.21	2.00	0.00	9.51	0.06	0.00	3.28	2.00	0.00	9.50	0.07	0.00
3.35	2.00	0.00	9.49	0.07	0.00	3.41	2.00	0.00	9.48	0.06	0.00
3.48	2.00	0.00	9.47	0.07	0.00	3.54	2.00	0.00	9.46	0.06	0.00
3.61	2.00	0.00	9.45	0.07	0.00	3.67	2.00	0.00	9.44	0.06	0.00
3.74	2.00	0.00	9.43	0.07	0.00	3.80	2.00	0.00	9.42	0.06	0.00
3.87	2.00	0.00	9.41	0.07	0.00	3.94	2.00	0.00	9.40	0.07	0.00
4.00	2.00	0.00	9.39	0.06	0.00	4.07	2.00	0.00	9.38	0.07	0.00
4.13	2.00	0.00	9.37	0.06	0.00	4.20	2.00	0.00	9.36	0.07	0.00
4.26	2.00	0.00	9.35	0.06	0.00	4.33	2.00	0.00	9.34	0.07	0.00
4.40	2.00	0.00	9.33	0.07	0.00	4.46	2.00	0.00	9.32	0.06	0.00
4.53	2.00	0.00	9.31	0.07	0.00	4.59	2.00	0.00	9.30	0.06	0.00
4.66	2.00	0.00	9.29	0.07	0.00	4.72	2.00	0.00	9.28	0.06	0.00
4.79	2.00	0.00	9.27	0.07	0.00	4.85	2.00	0.00	9.26	0.06	0.00
4.92	2.00	0.00	9.25	0.07	0.00	4.99	2.00	0.00	9.24	0.07	0.00
5.05	2.00	0.00	9.23	0.06	0.00	5.12	2.00	0.00	9.22	0.07	0.00
5.18	2.00	0.00	9.21	0.06	0.00	5.25	2.00	0.00	9.20	0.07	0.00
5.31	2.00	0.00	9.19	0.06	0.00	5.38	2.00	0.00	9.18	0.07	0.00
5.44	2.00	0.00	9.17	0.06	0.00	5.51	2.00	0.00	9.16	0.07	0.00
5.58	2.00	0.00	9.15	0.07	0.00	5.64	2.00	0.00	9.14	0.06	0.00
5.71	2.00	0.00	9.13	0.07	0.00	5.77	2.00	0.00	9.12	0.06	0.00
5.84	2.00	0.00	9.11	0.07	0.00	5.90	2.00	0.00	9.10	0.06	0.00
5.97	2.00	0.00	9.09	0.07	0.00	6.04	2.00	0.00	9.08	0.07	0.00
6.10	2.00	0.00	9.07	0.06	0.00	6.17	2.00	0.00	9.06	0.07	0.00
6.23	2.00	0.00	9.05	0.06	0.00	6.30	2.00	0.00	9.04	0.07	0.00

:: Liquefaction Potential Index calculation data :: (continued)											
Depth (ft)	FS	F_L	w_z	d_z	LPI	Depth (ft)	FS	F_L	w_z	d_z	LPI
6.36	2.00	0.00	9.03	0.06	0.00	6.43	2.00	0.00	9.02	0.07	0.00
6.49	2.00	0.00	9.01	0.06	0.00	6.56	2.00	0.00	9.00	0.07	0.00
6.63	2.00	0.00	8.99	0.07	0.00	6.69	2.00	0.00	8.98	0.06	0.00
6.76	2.00	0.00	8.97	0.07	0.00	6.82	2.00	0.00	8.96	0.06	0.00
6.89	2.00	0.00	8.95	0.07	0.00	6.95	2.00	0.00	8.94	0.06	0.00
7.02	2.00	0.00	8.93	0.07	0.00	7.08	2.00	0.00	8.92	0.06	0.00
7.15	2.00	0.00	8.91	0.07	0.00	7.22	2.00	0.00	8.90	0.07	0.00
7.28	2.00	0.00	8.89	0.06	0.00	7.35	2.00	0.00	8.88	0.07	0.00
7.41	2.00	0.00	8.87	0.06	0.00	7.48	2.00	0.00	8.86	0.07	0.00
7.54	2.00	0.00	8.85	0.06	0.00	7.61	2.00	0.00	8.84	0.07	0.00
7.68	2.00	0.00	8.83	0.07	0.00	7.74	2.00	0.00	8.82	0.06	0.00
7.81	2.00	0.00	8.81	0.07	0.00	7.87	2.00	0.00	8.80	0.06	0.00
7.94	2.00	0.00	8.79	0.07	0.00	8.00	2.00	0.00	8.78	0.06	0.00
8.07	2.00	0.00	8.77	0.07	0.00	8.13	2.00	0.00	8.76	0.06	0.00
8.20	2.00	0.00	8.75	0.07	0.00	8.27	2.00	0.00	8.74	0.07	0.00
8.33	2.00	0.00	8.73	0.06	0.00	8.40	2.00	0.00	8.72	0.07	0.00
8.46	2.00	0.00	8.71	0.06	0.00	8.53	2.00	0.00	8.70	0.07	0.00
8.59	2.00	0.00	8.69	0.06	0.00	8.66	2.00	0.00	8.68	0.07	0.00
8.72	2.00	0.00	8.67	0.06	0.00	8.79	2.00	0.00	8.66	0.07	0.00
8.86	2.00	0.00	8.65	0.07	0.00	8.92	2.00	0.00	8.64	0.06	0.00
8.99	2.00	0.00	8.63	0.07	0.00	9.05	2.00	0.00	8.62	0.06	0.00
9.12	2.00	0.00	8.61	0.07	0.00	9.18	2.00	0.00	8.60	0.06	0.00
9.25	2.00	0.00	8.59	0.07	0.00	9.32	2.00	0.00	8.58	0.07	0.00
9.38	2.00	0.00	8.57	0.06	0.00	9.45	2.00	0.00	8.56	0.07	0.00
9.51	2.00	0.00	8.55	0.06	0.00	9.58	2.00	0.00	8.54	0.07	0.00
9.64	2.00	0.00	8.53	0.06	0.00	9.71	2.00	0.00	8.52	0.07	0.00
9.77	2.00	0.00	8.51	0.06	0.00	9.84	2.00	0.00	8.50	0.07	0.00
9.91	1.91	0.00	8.49	0.07	0.00	9.97	1.81	0.00	8.48	0.06	0.00
10.04	1.70	0.00	8.47	0.07	0.00	10.10	1.61	0.00	8.46	0.06	0.00
10.17	1.60	0.00	8.45	0.07	0.00	10.23	1.61	0.00	8.44	0.06	0.00
10.30	1.66	0.00	8.43	0.07	0.00	10.36	1.67	0.00	8.42	0.06	0.00
10.43	1.67	0.00	8.41	0.07	0.00	10.50	1.67	0.00	8.40	0.07	0.00
10.56	1.65	0.00	8.39	0.06	0.00	10.63	1.63	0.00	8.38	0.07	0.00
10.69	1.62	0.00	8.37	0.06	0.00	10.76	1.60	0.00	8.36	0.07	0.00
10.82	1.60	0.00	8.35	0.06	0.00	10.89	1.59	0.00	8.34	0.07	0.00
10.96	1.55	0.00	8.33	0.07	0.00	11.02	1.54	0.00	8.32	0.06	0.00
11.09	1.55	0.00	8.31	0.07	0.00	11.15	1.55	0.00	8.30	0.06	0.00
11.22	1.50	0.00	8.29	0.07	0.00	11.28	1.46	0.00	8.28	0.06	0.00
11.35	1.47	0.00	8.27	0.07	0.00	11.41	1.51	0.00	8.26	0.06	0.00
11.48	1.57	0.00	8.25	0.07	0.00	11.55	1.60	0.00	8.24	0.07	0.00
11.61	1.63	0.00	8.23	0.06	0.00	11.68	1.62	0.00	8.22	0.07	0.00
11.74	1.64	0.00	8.21	0.06	0.00	11.81	1.64	0.00	8.20	0.07	0.00
11.87	1.62	0.00	8.19	0.06	0.00	11.94	1.57	0.00	8.18	0.07	0.00
12.00	1.55	0.00	8.17	0.06	0.00	12.07	1.53	0.00	8.16	0.07	0.00
12.14	1.54	0.00	8.15	0.07	0.00	12.20	1.53	0.00	8.14	0.06	0.00
12.27	1.51	0.00	8.13	0.07	0.00	12.33	1.49	0.00	8.12	0.06	0.00
12.40	1.48	0.00	8.11	0.07	0.00	12.46	1.47	0.00	8.10	0.06	0.00
12.53	1.48	0.00	8.09	0.07	0.00	12.60	1.48	0.00	8.08	0.07	0.00

:: Liquefaction Potential Index calculation data :: (continued)											
Depth (ft)	FS	F_L	w_z	d_z	LPI	Depth (ft)	FS	F_L	w_z	d_z	LPI
12.66	1.52	0.00	8.07	0.06	0.00	12.73	1.55	0.00	8.06	0.07	0.00
12.79	1.61	0.00	8.05	0.06	0.00	12.86	1.65	0.00	8.04	0.07	0.00
12.92	1.68	0.00	8.03	0.06	0.00	12.99	1.69	0.00	8.02	0.07	0.00
13.05	1.65	0.00	8.01	0.06	0.00	13.12	1.60	0.00	8.00	0.07	0.00
13.19	1.55	0.00	7.99	0.07	0.00	13.25	1.54	0.00	7.98	0.06	0.00
13.32	1.55	0.00	7.97	0.07	0.00	13.38	1.61	0.00	7.96	0.06	0.00
13.45	1.68	0.00	7.95	0.07	0.00	13.51	1.72	0.00	7.94	0.06	0.00
13.58	1.73	0.00	7.93	0.07	0.00	13.64	1.74	0.00	7.92	0.06	0.00
13.71	1.75	0.00	7.91	0.07	0.00	13.78	1.78	0.00	7.90	0.07	0.00
13.84	1.76	0.00	7.89	0.06	0.00	13.91	1.76	0.00	7.88	0.07	0.00
13.97	1.76	0.00	7.87	0.06	0.00	14.04	1.77	0.00	7.86	0.07	0.00
14.10	1.78	0.00	7.85	0.06	0.00	14.17	1.78	0.00	7.84	0.07	0.00
14.24	1.81	0.00	7.83	0.07	0.00	14.30	1.83	0.00	7.82	0.06	0.00
14.37	1.82	0.00	7.81	0.07	0.00	14.43	1.77	0.00	7.80	0.06	0.00
14.50	1.74	0.00	7.79	0.07	0.00	14.56	1.75	0.00	7.78	0.06	0.00
14.63	1.78	0.00	7.77	0.07	0.00	14.69	1.81	0.00	7.76	0.06	0.00
14.76	1.81	0.00	7.75	0.07	0.00	14.83	1.83	0.00	7.74	0.07	0.00
14.89	1.90	0.00	7.73	0.06	0.00	14.96	2.00	0.00	7.72	0.07	0.00
15.02	2.00	0.00	7.71	0.06	0.00	15.09	2.00	0.00	7.70	0.07	0.00
15.15	2.00	0.00	7.69	0.06	0.00	15.22	2.00	0.00	7.68	0.07	0.00
15.28	2.00	0.00	7.67	0.06	0.00	15.35	2.00	0.00	7.66	0.07	0.00
15.42	2.00	0.00	7.65	0.07	0.00	15.48	2.00	0.00	7.64	0.06	0.00
15.55	2.00	0.00	7.63	0.07	0.00	15.61	2.00	0.00	7.62	0.06	0.00
15.68	2.00	0.00	7.61	0.07	0.00	15.74	2.00	0.00	7.60	0.06	0.00
15.81	2.00	0.00	7.59	0.07	0.00	15.88	2.00	0.00	7.58	0.07	0.00
15.94	2.00	0.00	7.57	0.06	0.00	16.01	2.00	0.00	7.56	0.07	0.00
16.07	2.00	0.00	7.55	0.06	0.00	16.14	2.00	0.00	7.54	0.07	0.00
16.20	2.00	0.00	7.53	0.06	0.00	16.27	2.00	0.00	7.52	0.07	0.00
16.33	2.00	0.00	7.51	0.06	0.00	16.40	2.00	0.00	7.50	0.07	0.00
16.47	2.00	0.00	7.49	0.07	0.00	16.53	2.00	0.00	7.48	0.06	0.00
16.60	2.00	0.00	7.47	0.07	0.00	16.66	2.00	0.00	7.46	0.06	0.00
16.73	2.00	0.00	7.45	0.07	0.00	16.79	2.00	0.00	7.44	0.06	0.00
16.86	2.00	0.00	7.43	0.07	0.00	16.92	2.00	0.00	7.42	0.06	0.00
16.99	2.00	0.00	7.41	0.07	0.00	17.06	2.00	0.00	7.40	0.07	0.00
17.12	2.00	0.00	7.39	0.06	0.00	17.19	2.00	0.00	7.38	0.07	0.00
17.25	2.00	0.00	7.37	0.06	0.00	17.32	2.00	0.00	7.36	0.07	0.00
17.38	2.00	0.00	7.35	0.06	0.00	17.45	2.00	0.00	7.34	0.07	0.00
17.52	2.00	0.00	7.33	0.07	0.00	17.58	2.00	0.00	7.32	0.06	0.00
17.65	2.00	0.00	7.31	0.07	0.00	17.71	2.00	0.00	7.30	0.06	0.00
17.78	2.00	0.00	7.29	0.07	0.00	17.84	2.00	0.00	7.28	0.06	0.00
17.91	2.00	0.00	7.27	0.07	0.00	17.97	2.00	0.00	7.26	0.06	0.00
18.04	2.00	0.00	7.25	0.07	0.00	18.11	2.00	0.00	7.24	0.07	0.00
18.17	2.00	0.00	7.23	0.06	0.00	18.24	2.00	0.00	7.22	0.07	0.00
18.30	2.00	0.00	7.21	0.06	0.00	18.37	2.00	0.00	7.20	0.07	0.00
18.43	2.00	0.00	7.19	0.06	0.00	18.50	2.00	0.00	7.18	0.07	0.00
18.56	2.00	0.00	7.17	0.06	0.00	18.63	2.00	0.00	7.16	0.07	0.00
18.70	2.00	0.00	7.15	0.07	0.00	18.76	2.00	0.00	7.14	0.06	0.00
18.83	2.00	0.00	7.13	0.07	0.00	18.89	2.00	0.00	7.12	0.06	0.00

:: Liquefaction Potential Index calculation data :: (continued)											
Depth (ft)	FS	F_L	w_z	d_z	LPI	Depth (ft)	FS	F_L	w_z	d_z	LPI
18.96	2.00	0.00	7.11	0.07	0.00	19.02	2.00	0.00	7.10	0.06	0.00
19.09	2.00	0.00	7.09	0.07	0.00	19.16	2.00	0.00	7.08	0.07	0.00
19.22	2.00	0.00	7.07	0.06	0.00	19.29	2.00	0.00	7.06	0.07	0.00
19.35	2.00	0.00	7.05	0.06	0.00	19.42	2.00	0.00	7.04	0.07	0.00
19.48	2.00	0.00	7.03	0.06	0.00	19.55	2.00	0.00	7.02	0.07	0.00
19.61	2.00	0.00	7.01	0.06	0.00	19.68	2.00	0.00	7.00	0.07	0.00
19.75	2.00	0.00	6.99	0.07	0.00	19.81	2.00	0.00	6.98	0.06	0.00
19.88	2.00	0.00	6.97	0.07	0.00	19.94	2.00	0.00	6.96	0.06	0.00
20.01	2.00	0.00	6.95	0.07	0.00	20.07	2.00	0.00	6.94	0.06	0.00
20.14	2.00	0.00	6.93	0.07	0.00	20.20	2.00	0.00	6.92	0.06	0.00
20.27	2.00	0.00	6.91	0.07	0.00	20.34	2.00	0.00	6.90	0.07	0.00
20.40	2.00	0.00	6.89	0.06	0.00	20.47	2.00	0.00	6.88	0.07	0.00
20.53	2.00	0.00	6.87	0.06	0.00	20.60	2.00	0.00	6.86	0.07	0.00
20.66	2.00	0.00	6.85	0.06	0.00	20.73	2.00	0.00	6.84	0.07	0.00
20.80	2.00	0.00	6.83	0.07	0.00	20.86	2.00	0.00	6.82	0.06	0.00
20.93	2.00	0.00	6.81	0.07	0.00	20.99	2.00	0.00	6.80	0.06	0.00
21.06	2.00	0.00	6.79	0.07	0.00	21.12	2.00	0.00	6.78	0.06	0.00
21.19	2.00	0.00	6.77	0.07	0.00	21.25	2.00	0.00	6.76	0.06	0.00
21.32	2.00	0.00	6.75	0.07	0.00	21.39	2.00	0.00	6.74	0.07	0.00
21.45	2.00	0.00	6.73	0.06	0.00	21.52	2.00	0.00	6.72	0.07	0.00
21.58	2.00	0.00	6.71	0.06	0.00	21.65	2.00	0.00	6.70	0.07	0.00
21.71	2.00	0.00	6.69	0.06	0.00	21.78	2.00	0.00	6.68	0.07	0.00
21.84	2.00	0.00	6.67	0.06	0.00	21.91	2.00	0.00	6.66	0.07	0.00
21.98	2.00	0.00	6.65	0.07	0.00	22.04	2.00	0.00	6.64	0.06	0.00
22.11	2.00	0.00	6.63	0.07	0.00	22.17	2.00	0.00	6.62	0.06	0.00
22.24	2.00	0.00	6.61	0.07	0.00	22.30	2.00	0.00	6.60	0.06	0.00
22.37	2.00	0.00	6.59	0.07	0.00	22.44	2.00	0.00	6.58	0.07	0.00
22.50	2.00	0.00	6.57	0.06	0.00	22.57	2.00	0.00	6.56	0.07	0.00
22.63	2.00	0.00	6.55	0.06	0.00	22.70	2.00	0.00	6.54	0.07	0.00
22.76	2.00	0.00	6.53	0.06	0.00	22.83	2.00	0.00	6.52	0.07	0.00
22.89	2.00	0.00	6.51	0.06	0.00	22.96	2.00	0.00	6.50	0.07	0.00
23.03	2.00	0.00	6.49	0.07	0.00	23.09	2.00	0.00	6.48	0.06	0.00
23.16	2.00	0.00	6.47	0.07	0.00	23.22	2.00	0.00	6.46	0.06	0.00
23.29	2.00	0.00	6.45	0.07	0.00	23.35	2.00	0.00	6.44	0.06	0.00
23.42	2.00	0.00	6.43	0.07	0.00	23.48	2.00	0.00	6.42	0.06	0.00
23.55	2.00	0.00	6.41	0.07	0.00	23.62	2.00	0.00	6.40	0.07	0.00
23.68	2.00	0.00	6.39	0.06	0.00	23.75	2.00	0.00	6.38	0.07	0.00
23.81	2.00	0.00	6.37	0.06	0.00	23.88	2.00	0.00	6.36	0.07	0.00
23.94	2.00	0.00	6.35	0.06	0.00	24.01	2.00	0.00	6.34	0.07	0.00
24.08	2.00	0.00	6.33	0.07	0.00	24.14	2.00	0.00	6.32	0.06	0.00
24.21	2.00	0.00	6.31	0.07	0.00	24.27	2.00	0.00	6.30	0.06	0.00
24.34	2.00	0.00	6.29	0.07	0.00	24.40	2.00	0.00	6.28	0.06	0.00
24.47	2.00	0.00	6.27	0.07	0.00	24.53	2.00	0.00	6.26	0.06	0.00
24.60	2.00	0.00	6.25	0.07	0.00	24.67	2.00	0.00	6.24	0.07	0.00
24.73	2.00	0.00	6.23	0.06	0.00	24.80	2.00	0.00	6.22	0.07	0.00
24.86	2.00	0.00	6.21	0.06	0.00	24.93	2.00	0.00	6.20	0.07	0.00
24.99	2.00	0.00	6.19	0.06	0.00	25.06	2.00	0.00	6.18	0.07	0.00
25.12	2.00	0.00	6.17	0.06	0.00	25.19	2.00	0.00	6.16	0.07	0.00

:: Liquefaction Potential Index calculation data :: (continued)											
Depth (ft)	FS	F _L	w _z	d _z	LPI	Depth (ft)	FS	F _L	w _z	d _z	LPI
25.26	2.00	0.00	6.15	0.07	0.00	25.32	2.00	0.00	6.14	0.06	0.00
25.39	2.00	0.00	6.13	0.07	0.00	25.45	2.00	0.00	6.12	0.06	0.00
25.52	2.00	0.00	6.11	0.07	0.00	25.58	2.00	0.00	6.10	0.06	0.00
25.65	2.00	0.00	6.09	0.07	0.00	25.72	2.00	0.00	6.08	0.07	0.00
25.78	2.00	0.00	6.07	0.06	0.00	25.85	2.00	0.00	6.06	0.07	0.00
25.91	2.00	0.00	6.05	0.06	0.00	25.98	2.00	0.00	6.04	0.07	0.00
26.04	2.00	0.00	6.03	0.06	0.00	26.11	2.00	0.00	6.02	0.07	0.00
26.17	2.00	0.00	6.01	0.06	0.00	26.24	2.00	0.00	6.00	0.07	0.00
26.31	2.00	0.00	5.99	0.07	0.00	26.37	2.00	0.00	5.98	0.06	0.00
26.44	2.00	0.00	5.97	0.07	0.00	26.50	2.00	0.00	5.96	0.06	0.00
26.57	2.00	0.00	5.95	0.07	0.00	26.63	2.00	0.00	5.94	0.06	0.00
26.70	2.00	0.00	5.93	0.07	0.00	26.76	2.00	0.00	5.92	0.06	0.00
26.83	2.00	0.00	5.91	0.07	0.00	26.90	2.00	0.00	5.90	0.07	0.00
26.96	2.00	0.00	5.89	0.06	0.00	27.03	2.00	0.00	5.88	0.07	0.00
27.09	2.00	0.00	5.87	0.06	0.00	27.16	2.00	0.00	5.86	0.07	0.00
27.22	2.00	0.00	5.85	0.06	0.00	27.29	2.00	0.00	5.84	0.07	0.00
27.36	2.00	0.00	5.83	0.07	0.00	27.42	2.00	0.00	5.82	0.06	0.00
27.49	2.00	0.00	5.81	0.07	0.00	27.55	2.00	0.00	5.80	0.06	0.00
27.62	2.00	0.00	5.79	0.07	0.00	27.68	2.00	0.00	5.78	0.06	0.00
27.75	2.00	0.00	5.77	0.07	0.00	27.81	2.00	0.00	5.76	0.06	0.00
27.88	2.00	0.00	5.75	0.07	0.00	27.95	2.00	0.00	5.74	0.07	0.00
28.01	2.00	0.00	5.73	0.06	0.00	28.08	2.00	0.00	5.72	0.07	0.00
28.14	2.00	0.00	5.71	0.06	0.00	28.21	2.00	0.00	5.70	0.07	0.00
28.27	2.00	0.00	5.69	0.06	0.00	28.34	2.00	0.00	5.68	0.07	0.00
28.40	2.00	0.00	5.67	0.06	0.00	28.47	2.00	0.00	5.66	0.07	0.00
28.54	2.00	0.00	5.65	0.07	0.00	28.60	2.00	0.00	5.64	0.06	0.00
28.67	2.00	0.00	5.63	0.07	0.00	28.73	2.00	0.00	5.62	0.06	0.00
28.80	2.00	0.00	5.61	0.07	0.00	28.86	2.00	0.00	5.60	0.06	0.00
28.93	2.00	0.00	5.59	0.07	0.00	29.00	2.00	0.00	5.58	0.07	0.00
29.06	2.00	0.00	5.57	0.06	0.00	29.13	2.00	0.00	5.56	0.07	0.00
29.19	2.00	0.00	5.55	0.06	0.00	29.26	2.00	0.00	5.54	0.07	0.00
29.32	2.00	0.00	5.53	0.06	0.00	29.39	2.00	0.00	5.52	0.07	0.00
29.45	2.00	0.00	5.51	0.06	0.00	29.52	2.00	0.00	5.50	0.07	0.00
29.59	2.00	0.00	5.49	0.07	0.00	29.65	2.00	0.00	5.48	0.06	0.00
29.72	2.00	0.00	5.47	0.07	0.00	29.78	2.00	0.00	5.46	0.06	0.00
29.85	2.00	0.00	5.45	0.07	0.00	29.91	2.00	0.00	5.44	0.06	0.00
29.98	2.00	0.00	5.43	0.07	0.00	30.04	2.00	0.00	5.42	0.06	0.00
30.11	2.00	0.00	5.41	0.07	0.00	30.18	2.00	0.00	5.40	0.07	0.00
30.24	2.00	0.00	5.39	0.06	0.00	30.31	2.00	0.00	5.38	0.07	0.00
30.37	2.00	0.00	5.37	0.06	0.00	30.44	2.00	0.00	5.36	0.07	0.00
30.50	2.00	0.00	5.35	0.06	0.00	30.57	2.00	0.00	5.34	0.07	0.00
30.64	2.00	0.00	5.33	0.07	0.00	30.70	2.00	0.00	5.32	0.06	0.00
30.77	2.00	0.00	5.31	0.07	0.00	30.83	2.00	0.00	5.30	0.06	0.00
30.90	2.00	0.00	5.29	0.07	0.00	30.96	2.00	0.00	5.28	0.06	0.00
31.03	2.00	0.00	5.27	0.07	0.00	31.09	2.00	0.00	5.26	0.06	0.00
31.16	2.00	0.00	5.25	0.07	0.00	31.23	2.00	0.00	5.24	0.07	0.00
31.29	2.00	0.00	5.23	0.06	0.00	31.36	2.00	0.00	5.22	0.07	0.00
31.42	2.00	0.00	5.21	0.06	0.00	31.49	2.00	0.00	5.20	0.07	0.00

:: Liquefaction Potential Index calculation data :: (continued)											
Depth (ft)	FS	F_L	w_z	d_z	LPI	Depth (ft)	FS	F_L	w_z	d_z	LPI
31.55	2.00	0.00	5.19	0.06	0.00	31.62	2.00	0.00	5.18	0.07	0.00
31.68	2.00	0.00	5.17	0.06	0.00	31.75	2.00	0.00	5.16	0.07	0.00
31.82	2.00	0.00	5.15	0.07	0.00	31.88	2.00	0.00	5.14	0.06	0.00
31.95	2.00	0.00	5.13	0.07	0.00	32.01	2.00	0.00	5.12	0.06	0.00
32.08	2.00	0.00	5.11	0.07	0.00	32.14	2.00	0.00	5.10	0.06	0.00
32.21	2.00	0.00	5.09	0.07	0.00	32.28	2.00	0.00	5.08	0.07	0.00
32.34	2.00	0.00	5.07	0.06	0.00	32.41	2.00	0.00	5.06	0.07	0.00
32.47	2.00	0.00	5.05	0.06	0.00	32.54	2.00	0.00	5.04	0.07	0.00
32.60	2.00	0.00	5.03	0.06	0.00	32.67	2.00	0.00	5.02	0.07	0.00
32.73	2.00	0.00	5.01	0.06	0.00	32.80	2.00	0.00	5.00	0.07	0.00
32.87	2.00	0.00	4.99	0.07	0.00	32.93	2.00	0.00	4.98	0.06	0.00
33.00	2.00	0.00	4.97	0.07	0.00	33.06	2.00	0.00	4.96	0.06	0.00
33.13	2.00	0.00	4.95	0.07	0.00	33.19	2.00	0.00	4.94	0.06	0.00
33.26	2.00	0.00	4.93	0.07	0.00	33.32	2.00	0.00	4.92	0.06	0.00
33.39	2.00	0.00	4.91	0.07	0.00	33.46	2.00	0.00	4.90	0.07	0.00
33.52	2.00	0.00	4.89	0.06	0.00	33.59	2.00	0.00	4.88	0.07	0.00
33.65	2.00	0.00	4.87	0.06	0.00	33.72	2.00	0.00	4.86	0.07	0.00
33.78	2.00	0.00	4.85	0.06	0.00	33.85	2.00	0.00	4.84	0.07	0.00
33.92	2.00	0.00	4.83	0.07	0.00	33.98	2.00	0.00	4.82	0.06	0.00
34.05	2.00	0.00	4.81	0.07	0.00	34.11	2.00	0.00	4.80	0.06	0.00
34.18	2.00	0.00	4.79	0.07	0.00	34.24	2.00	0.00	4.78	0.06	0.00
34.31	2.00	0.00	4.77	0.07	0.00	34.37	2.00	0.00	4.76	0.06	0.00
34.44	2.00	0.00	4.75	0.07	0.00	34.51	2.00	0.00	4.74	0.07	0.00
34.57	2.00	0.00	4.73	0.06	0.00	34.64	2.00	0.00	4.72	0.07	0.00
34.70	2.00	0.00	4.71	0.06	0.00	34.77	2.00	0.00	4.70	0.07	0.00
34.83	2.00	0.00	4.69	0.06	0.00	34.90	2.00	0.00	4.68	0.07	0.00
34.96	2.00	0.00	4.67	0.06	0.00	35.03	2.00	0.00	4.66	0.07	0.00
35.10	2.00	0.00	4.65	0.07	0.00	35.16	2.00	0.00	4.64	0.06	0.00
35.23	2.00	0.00	4.63	0.07	0.00	35.29	2.00	0.00	4.62	0.06	0.00
35.36	2.00	0.00	4.61	0.07	0.00	35.42	2.00	0.00	4.60	0.06	0.00
35.49	2.00	0.00	4.59	0.07	0.00	35.56	2.00	0.00	4.58	0.07	0.00
35.62	2.00	0.00	4.57	0.06	0.00	35.69	2.00	0.00	4.56	0.07	0.00
35.75	2.00	0.00	4.55	0.06	0.00	35.82	2.00	0.00	4.54	0.07	0.00
35.88	2.00	0.00	4.53	0.06	0.00	35.95	2.00	0.00	4.52	0.07	0.00
36.01	2.00	0.00	4.51	0.06	0.00	36.08	2.00	0.00	4.50	0.07	0.00
36.15	2.00	0.00	4.49	0.07	0.00	36.21	2.00	0.00	4.48	0.06	0.00
36.28	2.00	0.00	4.47	0.07	0.00	36.34	2.00	0.00	4.46	0.06	0.00
36.41	2.00	0.00	4.45	0.07	0.00	36.47	2.00	0.00	4.44	0.06	0.00
36.54	2.00	0.00	4.43	0.07	0.00	36.60	2.00	0.00	4.42	0.06	0.00
36.67	2.00	0.00	4.41	0.07	0.00	36.74	2.00	0.00	4.40	0.07	0.00
36.80	2.00	0.00	4.39	0.06	0.00	36.87	2.00	0.00	4.38	0.07	0.00
36.93	2.00	0.00	4.37	0.06	0.00	37.00	2.00	0.00	4.36	0.07	0.00
37.06	2.00	0.00	4.35	0.06	0.00	37.13	2.00	0.00	4.34	0.07	0.00
37.20	2.00	0.00	4.33	0.07	0.00	37.26	2.00	0.00	4.32	0.06	0.00
37.33	2.00	0.00	4.31	0.07	0.00	37.39	2.00	0.00	4.30	0.06	0.00
37.46	2.00	0.00	4.29	0.07	0.00	37.52	2.00	0.00	4.28	0.06	0.00
37.59	2.00	0.00	4.27	0.07	0.00	37.65	2.00	0.00	4.26	0.06	0.00
37.72	2.00	0.00	4.25	0.07	0.00	37.79	2.00	0.00	4.24	0.07	0.00

:: Liquefaction Potential Index calculation data :: (continued)											
Depth (ft)	FS	F_L	w_z	d_z	LPI	Depth (ft)	FS	F_L	w_z	d_z	LPI
37.85	2.00	0.00	4.23	0.06	0.00	37.92	2.00	0.00	4.22	0.07	0.00
37.98	2.00	0.00	4.21	0.06	0.00	38.05	2.00	0.00	4.20	0.07	0.00
38.11	2.00	0.00	4.19	0.06	0.00	38.18	2.00	0.00	4.18	0.07	0.00
38.24	2.00	0.00	4.17	0.06	0.00	38.31	2.00	0.00	4.16	0.07	0.00
38.38	2.00	0.00	4.15	0.07	0.00	38.44	2.00	0.00	4.14	0.06	0.00
38.51	2.00	0.00	4.13	0.07	0.00	38.57	2.00	0.00	4.12	0.06	0.00
38.64	2.00	0.00	4.11	0.07	0.00	38.70	2.00	0.00	4.10	0.06	0.00
38.77	2.00	0.00	4.09	0.07	0.00	38.84	2.00	0.00	4.08	0.07	0.00
38.90	2.00	0.00	4.07	0.06	0.00	38.97	2.00	0.00	4.06	0.07	0.00
39.03	2.00	0.00	4.05	0.06	0.00	39.10	2.00	0.00	4.04	0.07	0.00
39.16	2.00	0.00	4.03	0.06	0.00	39.23	2.00	0.00	4.02	0.07	0.00
39.29	2.00	0.00	4.01	0.06	0.00	39.36	2.00	0.00	4.00	0.07	0.00
39.43	2.00	0.00	3.99	0.07	0.00	39.49	2.00	0.00	3.98	0.06	0.00
39.56	2.00	0.00	3.97	0.07	0.00	39.62	2.00	0.00	3.96	0.06	0.00
39.69	2.00	0.00	3.95	0.07	0.00	39.75	2.00	0.00	3.94	0.06	0.00
39.82	2.00	0.00	3.93	0.07	0.00	39.88	2.00	0.00	3.92	0.06	0.00
39.95	2.00	0.00	3.91	0.07	0.00	40.02	2.00	0.00	3.90	0.07	0.00
40.08	1.57	0.00	3.89	0.06	0.00	40.15	2.00	0.00	3.88	0.07	0.00
40.21	2.00	0.00	3.87	0.06	0.00						

Overall liquefaction potential: 0.00

LPI = 0.00 - Liquefaction risk very low
 LPI between 0.00 and 5.00 - Liquefaction risk low
 LPI between 5.00 and 15.00 - Liquefaction risk high
 LPI > 15.00 - Liquefaction risk very high

Abbreviations

FS: Calculated factor of safety for test point
 F_L : 1 - FS
 w_z : Function value of the extend of soil liquefaction according to depth
 d_z : Layer thickness (ft)
 LPI: Liquefaction potential index value for test point

LIQUEFACTION ANALYSIS REPORT

Project title : Martin Lake

Location : PDP-5

CPT file : B-12

Input parameters and analysis data

Analysis method:	Robertson (2009)	G.W.T. (in-situ):	1.00 ft	Use fill:	No	Clay like behavior applied:	All soils
Fines correction method:	Robertson (2009)	G.W.T. (earthq.):	0.00 ft	Fill height:	N/A	Limit depth applied:	No
Points to test:	Based on Ic value	Average results interval:	3	Fill weight:	N/A	Limit depth:	N/A
Earthquake magnitude M_w :	6.20	Ic cut-off value:	2.60	Trans. detect. applied:	No	MSF method:	Method based
Peak ground acceleration:	0.09	Unit weight calculation:	Based on SBT	K_0 applied:	Yes		

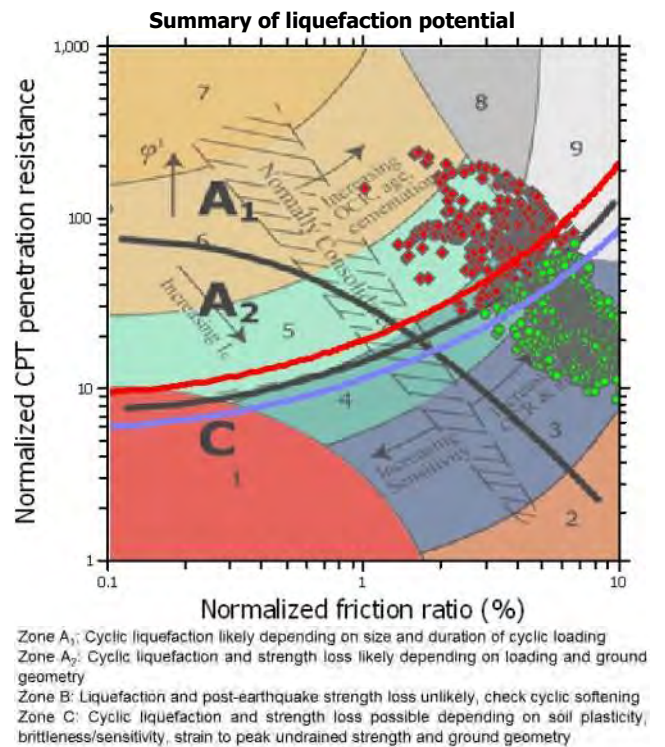
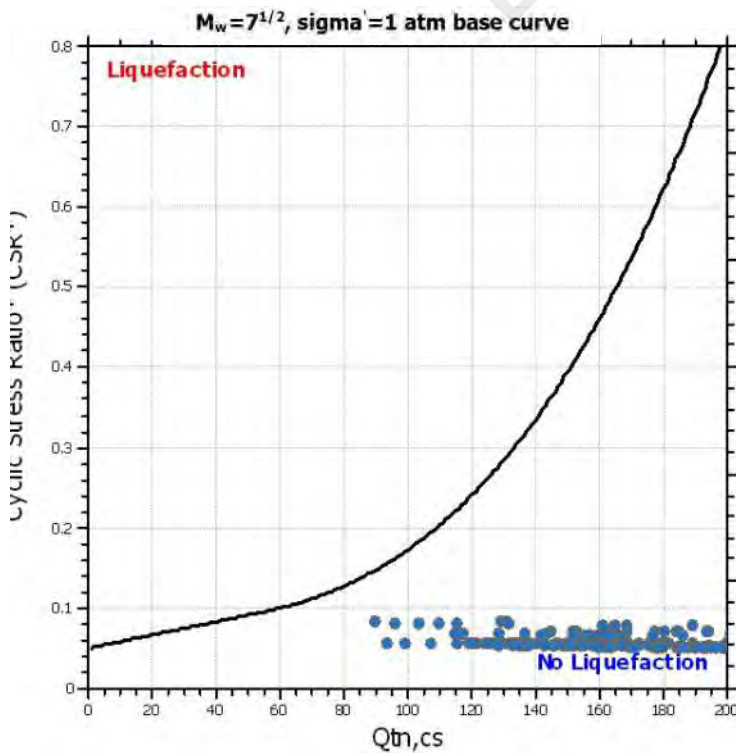
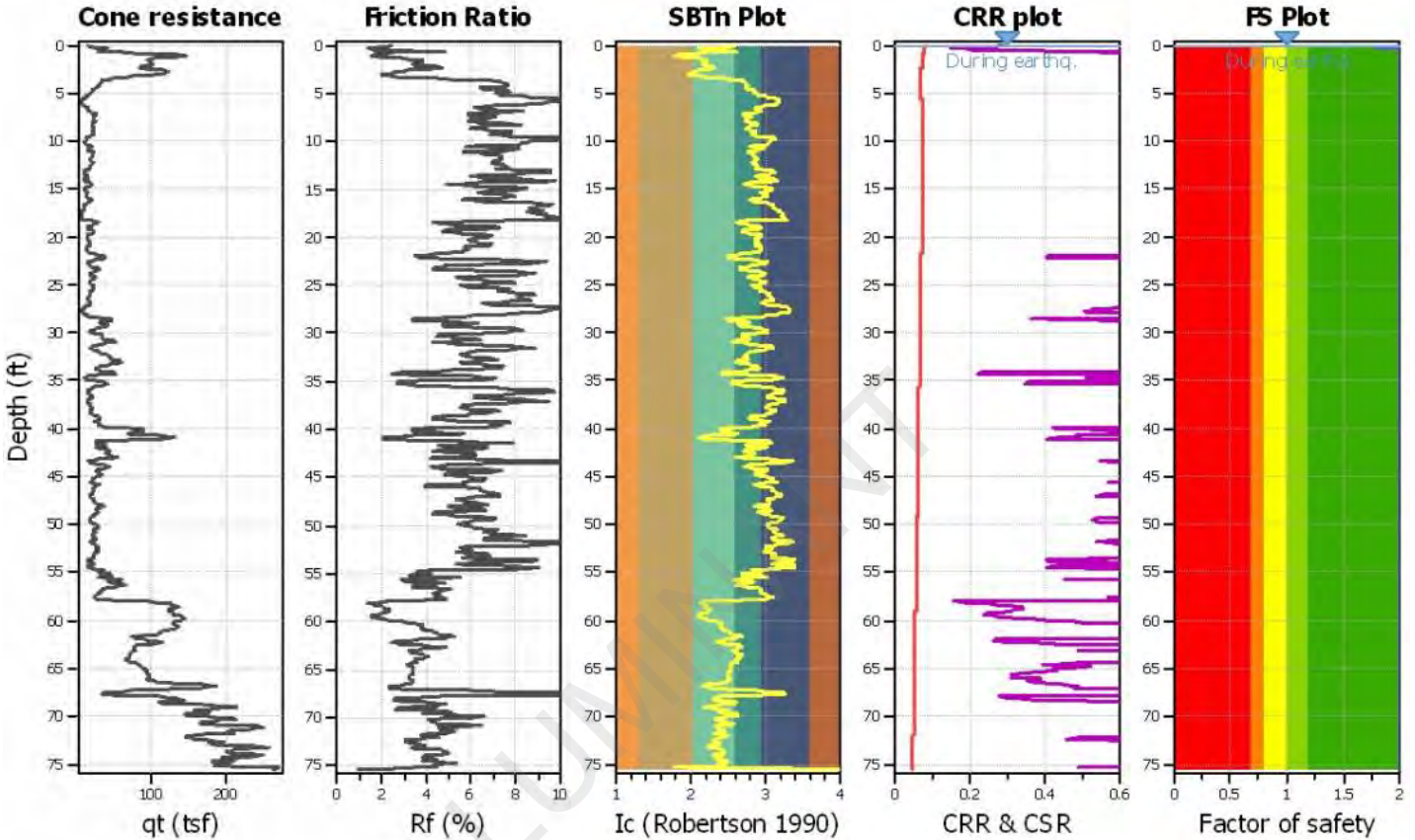

:: Liquefaction Potential Index calculation data ::											
Depth (ft)	FS	F_L	w_z	d_z	LPI	Depth (ft)	FS	F_L	w_z	d_z	LPI
0.07	2.00	0.00	9.99	0.06	0.00	0.13	2.00	0.00	9.98	0.06	0.00
0.20	1.80	0.00	9.97	0.07	0.00	0.26	2.00	0.00	9.96	0.06	0.00
0.33	2.00	0.00	9.95	0.07	0.00	0.39	2.00	0.00	9.94	0.06	0.00
0.46	2.00	0.00	9.93	0.07	0.00	0.52	2.00	0.00	9.92	0.06	0.00
0.59	2.00	0.00	9.91	0.07	0.00	0.66	2.00	0.00	9.90	0.07	0.00
0.72	2.00	0.00	9.89	0.06	0.00	0.79	2.00	0.00	9.88	0.07	0.00
0.85	2.00	0.00	9.87	0.06	0.00	0.92	2.00	0.00	9.86	0.07	0.00
0.98	2.00	0.00	9.85	0.06	0.00	1.05	2.00	0.00	9.84	0.07	0.00
1.12	2.00	0.00	9.83	0.07	0.00	1.18	2.00	0.00	9.82	0.06	0.00
1.25	2.00	0.00	9.81	0.07	0.00	1.31	2.00	0.00	9.80	0.06	0.00
1.38	2.00	0.00	9.79	0.07	0.00	1.44	2.00	0.00	9.78	0.06	0.00
1.51	2.00	0.00	9.77	0.07	0.00	1.57	2.00	0.00	9.76	0.06	0.00
1.64	2.00	0.00	9.75	0.07	0.00	1.71	2.00	0.00	9.74	0.07	0.00
1.77	2.00	0.00	9.73	0.06	0.00	1.84	2.00	0.00	9.72	0.07	0.00
1.90	2.00	0.00	9.71	0.06	0.00	1.97	2.00	0.00	9.70	0.07	0.00
2.03	2.00	0.00	9.69	0.06	0.00	2.10	2.00	0.00	9.68	0.07	0.00
2.16	2.00	0.00	9.67	0.06	0.00	2.23	2.00	0.00	9.66	0.07	0.00
2.30	2.00	0.00	9.65	0.07	0.00	2.36	2.00	0.00	9.64	0.06	0.00
2.43	2.00	0.00	9.63	0.07	0.00	2.49	2.00	0.00	9.62	0.06	0.00
2.56	2.00	0.00	9.61	0.07	0.00	2.62	2.00	0.00	9.60	0.06	0.00
2.69	2.00	0.00	9.59	0.07	0.00	2.76	2.00	0.00	9.58	0.07	0.00
2.82	2.00	0.00	9.57	0.06	0.00	2.89	2.00	0.00	9.56	0.07	0.00
2.95	2.00	0.00	9.55	0.06	0.00	3.02	2.00	0.00	9.54	0.07	0.00
3.08	2.00	0.00	9.53	0.06	0.00	3.15	2.00	0.00	9.52	0.07	0.00
3.21	2.00	0.00	9.51	0.06	0.00	3.28	2.00	0.00	9.50	0.07	0.00
3.35	2.00	0.00	9.49	0.07	0.00	3.41	2.00	0.00	9.48	0.06	0.00
3.48	2.00	0.00	9.47	0.07	0.00	3.54	2.00	0.00	9.46	0.06	0.00
3.61	2.00	0.00	9.45	0.07	0.00	3.67	2.00	0.00	9.44	0.06	0.00
3.74	2.00	0.00	9.43	0.07	0.00	3.80	2.00	0.00	9.42	0.06	0.00
3.87	2.00	0.00	9.41	0.07	0.00	3.94	2.00	0.00	9.40	0.07	0.00
4.00	2.00	0.00	9.39	0.06	0.00	4.07	2.00	0.00	9.38	0.07	0.00
4.13	2.00	0.00	9.37	0.06	0.00	4.20	2.00	0.00	9.36	0.07	0.00
4.26	2.00	0.00	9.35	0.06	0.00	4.33	2.00	0.00	9.34	0.07	0.00
4.40	2.00	0.00	9.33	0.07	0.00	4.46	2.00	0.00	9.32	0.06	0.00
4.53	2.00	0.00	9.31	0.07	0.00	4.59	2.00	0.00	9.30	0.06	0.00
4.66	2.00	0.00	9.29	0.07	0.00	4.72	2.00	0.00	9.28	0.06	0.00
4.79	2.00	0.00	9.27	0.07	0.00	4.85	2.00	0.00	9.26	0.06	0.00
4.92	2.00	0.00	9.25	0.07	0.00	4.99	2.00	0.00	9.24	0.07	0.00
5.05	2.00	0.00	9.23	0.06	0.00	5.12	2.00	0.00	9.22	0.07	0.00
5.18	2.00	0.00	9.21	0.06	0.00	5.25	2.00	0.00	9.20	0.07	0.00
5.31	2.00	0.00	9.19	0.06	0.00	5.38	2.00	0.00	9.18	0.07	0.00
5.44	2.00	0.00	9.17	0.06	0.00	5.51	2.00	0.00	9.16	0.07	0.00
5.58	2.00	0.00	9.15	0.07	0.00	5.64	2.00	0.00	9.14	0.06	0.00
5.71	2.00	0.00	9.13	0.07	0.00	5.77	2.00	0.00	9.12	0.06	0.00
5.84	2.00	0.00	9.11	0.07	0.00	5.90	2.00	0.00	9.10	0.06	0.00
5.97	2.00	0.00	9.09	0.07	0.00	6.04	2.00	0.00	9.08	0.07	0.00
6.10	2.00	0.00	9.07	0.06	0.00	6.17	2.00	0.00	9.06	0.07	0.00
6.23	2.00	0.00	9.05	0.06	0.00	6.30	2.00	0.00	9.04	0.07	0.00

:: Liquefaction Potential Index calculation data :: (continued)											
Depth (ft)	FS	F_L	w_z	d_z	LPI	Depth (ft)	FS	F_L	w_z	d_z	LPI
6.36	2.00	0.00	9.03	0.06	0.00	6.43	2.00	0.00	9.02	0.07	0.00
6.49	2.00	0.00	9.01	0.06	0.00	6.56	2.00	0.00	9.00	0.07	0.00
6.63	2.00	0.00	8.99	0.07	0.00	6.69	2.00	0.00	8.98	0.06	0.00
6.76	2.00	0.00	8.97	0.07	0.00	6.82	2.00	0.00	8.96	0.06	0.00
6.89	2.00	0.00	8.95	0.07	0.00	6.95	2.00	0.00	8.94	0.06	0.00
7.02	2.00	0.00	8.93	0.07	0.00	7.08	2.00	0.00	8.92	0.06	0.00
7.15	2.00	0.00	8.91	0.07	0.00	7.22	2.00	0.00	8.90	0.07	0.00
7.28	2.00	0.00	8.89	0.06	0.00	7.35	2.00	0.00	8.88	0.07	0.00
7.41	2.00	0.00	8.87	0.06	0.00	7.48	2.00	0.00	8.86	0.07	0.00
7.54	2.00	0.00	8.85	0.06	0.00	7.61	2.00	0.00	8.84	0.07	0.00
7.68	2.00	0.00	8.83	0.07	0.00	7.74	2.00	0.00	8.82	0.06	0.00
7.81	2.00	0.00	8.81	0.07	0.00	7.87	2.00	0.00	8.80	0.06	0.00
7.94	2.00	0.00	8.79	0.07	0.00	8.00	2.00	0.00	8.78	0.06	0.00
8.07	2.00	0.00	8.77	0.07	0.00	8.13	2.00	0.00	8.76	0.06	0.00
8.20	2.00	0.00	8.75	0.07	0.00	8.27	2.00	0.00	8.74	0.07	0.00
8.33	2.00	0.00	8.73	0.06	0.00	8.40	2.00	0.00	8.72	0.07	0.00
8.46	2.00	0.00	8.71	0.06	0.00	8.53	2.00	0.00	8.70	0.07	0.00
8.59	2.00	0.00	8.69	0.06	0.00	8.66	2.00	0.00	8.68	0.07	0.00
8.72	2.00	0.00	8.67	0.06	0.00	8.79	2.00	0.00	8.66	0.07	0.00
8.86	2.00	0.00	8.65	0.07	0.00	8.92	2.00	0.00	8.64	0.06	0.00
8.99	2.00	0.00	8.63	0.07	0.00	9.05	2.00	0.00	8.62	0.06	0.00
9.12	2.00	0.00	8.61	0.07	0.00	9.18	2.00	0.00	8.60	0.06	0.00
9.25	2.00	0.00	8.59	0.07	0.00	9.32	2.00	0.00	8.58	0.07	0.00
9.38	2.00	0.00	8.57	0.06	0.00	9.45	2.00	0.00	8.56	0.07	0.00
9.51	2.00	0.00	8.55	0.06	0.00	9.58	2.00	0.00	8.54	0.07	0.00
9.64	2.00	0.00	8.53	0.06	0.00	9.71	2.00	0.00	8.52	0.07	0.00
9.77	2.00	0.00	8.51	0.06	0.00	9.84	2.00	0.00	8.50	0.07	0.00
9.91	2.00	0.00	8.49	0.07	0.00	9.97	2.00	0.00	8.48	0.06	0.00
10.04	2.00	0.00	8.47	0.07	0.00	10.10	2.00	0.00	8.46	0.06	0.00
10.17	2.00	0.00	8.45	0.07	0.00	10.23	2.00	0.00	8.44	0.06	0.00
10.30	2.00	0.00	8.43	0.07	0.00	10.36	2.00	0.00	8.42	0.06	0.00
10.43	2.00	0.00	8.41	0.07	0.00	10.50	2.00	0.00	8.40	0.07	0.00
10.56	2.00	0.00	8.39	0.06	0.00	10.63	2.00	0.00	8.38	0.07	0.00
10.69	2.00	0.00	8.37	0.06	0.00	10.76	2.00	0.00	8.36	0.07	0.00
10.82	2.00	0.00	8.35	0.06	0.00	10.89	2.00	0.00	8.34	0.07	0.00
10.96	2.00	0.00	8.33	0.07	0.00	11.02	2.00	0.00	8.32	0.06	0.00
11.09	2.00	0.00	8.31	0.07	0.00	11.15	2.00	0.00	8.30	0.06	0.00
11.22	2.00	0.00	8.29	0.07	0.00	11.28	2.00	0.00	8.28	0.06	0.00
11.35	2.00	0.00	8.27	0.07	0.00	11.41	2.00	0.00	8.26	0.06	0.00
11.48	2.00	0.00	8.25	0.07	0.00	11.55	2.00	0.00	8.24	0.07	0.00
11.61	2.00	0.00	8.23	0.06	0.00	11.68	2.00	0.00	8.22	0.07	0.00
11.74	2.00	0.00	8.21	0.06	0.00	11.81	2.00	0.00	8.20	0.07	0.00
11.87	2.00	0.00	8.19	0.06	0.00	11.94	2.00	0.00	8.18	0.07	0.00
12.00	2.00	0.00	8.17	0.06	0.00	12.07	2.00	0.00	8.16	0.07	0.00
12.14	2.00	0.00	8.15	0.07	0.00	12.20	2.00	0.00	8.14	0.06	0.00
12.27	2.00	0.00	8.13	0.07	0.00	12.33	2.00	0.00	8.12	0.06	0.00
12.40	2.00	0.00	8.11	0.07	0.00	12.46	2.00	0.00	8.10	0.06	0.00
12.53	2.00	0.00	8.09	0.07	0.00	12.60	2.00	0.00	8.08	0.07	0.00

:: Liquefaction Potential Index calculation data :: (continued)											
Depth (ft)	FS	F _L	w _z	d _z	LPI	Depth (ft)	FS	F _L	w _z	d _z	LPI
12.66	2.00	0.00	8.07	0.06	0.00	12.73	2.00	0.00	8.06	0.07	0.00
12.79	2.00	0.00	8.05	0.06	0.00	12.86	2.00	0.00	8.04	0.07	0.00
12.92	2.00	0.00	8.03	0.06	0.00	12.99	2.00	0.00	8.02	0.07	0.00
13.05	2.00	0.00	8.01	0.06	0.00	13.12	2.00	0.00	8.00	0.07	0.00
13.19	2.00	0.00	7.99	0.07	0.00	13.25	2.00	0.00	7.98	0.06	0.00
13.32	2.00	0.00	7.97	0.07	0.00	13.38	2.00	0.00	7.96	0.06	0.00
13.45	2.00	0.00	7.95	0.07	0.00	13.51	2.00	0.00	7.94	0.06	0.00
13.58	2.00	0.00	7.93	0.07	0.00	13.64	2.00	0.00	7.92	0.06	0.00
13.71	2.00	0.00	7.91	0.07	0.00	13.78	2.00	0.00	7.90	0.07	0.00
13.84	2.00	0.00	7.89	0.06	0.00	13.91	2.00	0.00	7.88	0.07	0.00
13.97	2.00	0.00	7.87	0.06	0.00	14.04	2.00	0.00	7.86	0.07	0.00
14.10	2.00	0.00	7.85	0.06	0.00	14.17	2.00	0.00	7.84	0.07	0.00
14.24	2.00	0.00	7.83	0.07	0.00	14.30	2.00	0.00	7.82	0.06	0.00
14.37	2.00	0.00	7.81	0.07	0.00	14.43	2.00	0.00	7.80	0.06	0.00
14.50	2.00	0.00	7.79	0.07	0.00	14.56	2.00	0.00	7.78	0.06	0.00
14.63	2.00	0.00	7.77	0.07	0.00	14.69	2.00	0.00	7.76	0.06	0.00
14.76	2.00	0.00	7.75	0.07	0.00	14.83	2.00	0.00	7.74	0.07	0.00
14.89	2.00	0.00	7.73	0.06	0.00	14.96	2.00	0.00	7.72	0.07	0.00
15.02	2.00	0.00	7.71	0.06	0.00	15.09	2.00	0.00	7.70	0.07	0.00
15.15	2.00	0.00	7.69	0.06	0.00	15.22	2.00	0.00	7.68	0.07	0.00
15.28	2.00	0.00	7.67	0.06	0.00	15.35	2.00	0.00	7.66	0.07	0.00
15.42	2.00	0.00	7.65	0.07	0.00	15.48	2.00	0.00	7.64	0.06	0.00
15.55	2.00	0.00	7.63	0.07	0.00	15.61	2.00	0.00	7.62	0.06	0.00
15.68	2.00	0.00	7.61	0.07	0.00	15.74	2.00	0.00	7.60	0.06	0.00
15.81	2.00	0.00	7.59	0.07	0.00	15.88	2.00	0.00	7.58	0.07	0.00
15.94	2.00	0.00	7.57	0.06	0.00	16.01	2.00	0.00	7.56	0.07	0.00
16.07	2.00	0.00	7.55	0.06	0.00	16.14	2.00	0.00	7.54	0.07	0.00
16.20	2.00	0.00	7.53	0.06	0.00	16.27	2.00	0.00	7.52	0.07	0.00
16.33	2.00	0.00	7.51	0.06	0.00	16.40	2.00	0.00	7.50	0.07	0.00
16.47	2.00	0.00	7.49	0.07	0.00	16.53	2.00	0.00	7.48	0.06	0.00
16.60	2.00	0.00	7.47	0.07	0.00	16.66	2.00	0.00	7.46	0.06	0.00
16.73	2.00	0.00	7.45	0.07	0.00	16.79	2.00	0.00	7.44	0.06	0.00
16.86	2.00	0.00	7.43	0.07	0.00	16.92	2.00	0.00	7.42	0.06	0.00
16.99	2.00	0.00	7.41	0.07	0.00	17.06	2.00	0.00	7.40	0.07	0.00
17.12	2.00	0.00	7.39	0.06	0.00	17.19	2.00	0.00	7.38	0.07	0.00
17.25	2.00	0.00	7.37	0.06	0.00	17.32	2.00	0.00	7.36	0.07	0.00
17.38	2.00	0.00	7.35	0.06	0.00	17.45	2.00	0.00	7.34	0.07	0.00
17.52	2.00	0.00	7.33	0.07	0.00	17.58	2.00	0.00	7.32	0.06	0.00
17.65	2.00	0.00	7.31	0.07	0.00	17.71	2.00	0.00	7.30	0.06	0.00
17.78	2.00	0.00	7.29	0.07	0.00	17.84	2.00	0.00	7.28	0.06	0.00
17.91	2.00	0.00	7.27	0.07	0.00	17.97	2.00	0.00	7.26	0.06	0.00
18.04	2.00	0.00	7.25	0.07	0.00	18.11	2.00	0.00	7.24	0.07	0.00
18.17	2.00	0.00	7.23	0.06	0.00	18.24	2.00	0.00	7.22	0.07	0.00
18.30	2.00	0.00	7.21	0.06	0.00	18.37	2.00	0.00	7.20	0.07	0.00
18.43	2.00	0.00	7.19	0.06	0.00	18.50	2.00	0.00	7.18	0.07	0.00
18.56	2.00	0.00	7.17	0.06	0.00	18.63	2.00	0.00	7.16	0.07	0.00
18.70	2.00	0.00	7.15	0.07	0.00	18.76	2.00	0.00	7.14	0.06	0.00
18.83	2.00	0.00	7.13	0.07	0.00	18.89	2.00	0.00	7.12	0.06	0.00

:: Liquefaction Potential Index calculation data :: (continued)											
Depth (ft)	FS	F _L	w _z	d _z	LPI	Depth (ft)	FS	F _L	w _z	d _z	LPI
18.96	2.00	0.00	7.11	0.07	0.00	19.02	2.00	0.00	7.10	0.06	0.00
19.09	2.00	0.00	7.09	0.07	0.00	19.16	2.00	0.00	7.08	0.07	0.00
19.22	2.00	0.00	7.07	0.06	0.00	19.29	2.00	0.00	7.06	0.07	0.00
19.35	2.00	0.00	7.05	0.06	0.00	19.42	2.00	0.00	7.04	0.07	0.00
19.48	2.00	0.00	7.03	0.06	0.00	19.55	2.00	0.00	7.02	0.07	0.00
19.61	2.00	0.00	7.01	0.06	0.00	19.68	2.00	0.00	7.00	0.07	0.00
19.75	2.00	0.00	6.99	0.07	0.00	19.81	2.00	0.00	6.98	0.06	0.00
19.88	2.00	0.00	6.97	0.07	0.00	19.94	2.00	0.00	6.96	0.06	0.00
20.01	2.00	0.00	6.95	0.07	0.00	20.07	2.00	0.00	6.94	0.06	0.00
20.14	2.00	0.00	6.93	0.07	0.00	20.20	2.00	0.00	6.92	0.06	0.00
20.27	2.00	0.00	6.91	0.07	0.00	20.34	2.00	0.00	6.90	0.07	0.00
20.40	2.00	0.00	6.89	0.06	0.00	20.47	2.00	0.00	6.88	0.07	0.00
20.53	2.00	0.00	6.87	0.06	0.00	20.60	2.00	0.00	6.86	0.07	0.00
20.66	2.00	0.00	6.85	0.06	0.00	20.73	2.00	0.00	6.84	0.07	0.00
20.80	2.00	0.00	6.83	0.07	0.00	20.86	2.00	0.00	6.82	0.06	0.00
20.93	2.00	0.00	6.81	0.07	0.00	20.99	2.00	0.00	6.80	0.06	0.00
21.06	2.00	0.00	6.79	0.07	0.00	21.12	2.00	0.00	6.78	0.06	0.00
21.19	2.00	0.00	6.77	0.07	0.00	21.25	2.00	0.00	6.76	0.06	0.00
21.32	2.00	0.00	6.75	0.07	0.00	21.39	2.00	0.00	6.74	0.07	0.00
21.45	2.00	0.00	6.73	0.06	0.00	21.52	2.00	0.00	6.72	0.07	0.00
21.58	2.00	0.00	6.71	0.06	0.00	21.65	2.00	0.00	6.70	0.07	0.00
21.71	2.00	0.00	6.69	0.06	0.00	21.78	2.00	0.00	6.68	0.07	0.00
21.84	2.00	0.00	6.67	0.06	0.00	21.91	2.00	0.00	6.66	0.07	0.00
21.98	2.00	0.00	6.65	0.07	0.00	22.04	2.00	0.00	6.64	0.06	0.00
22.11	2.00	0.00	6.63	0.07	0.00	22.17	2.00	0.00	6.62	0.06	0.00
22.24	2.00	0.00	6.61	0.07	0.00	22.30	2.00	0.00	6.60	0.06	0.00
22.37	2.00	0.00	6.59	0.07	0.00	22.44	2.00	0.00	6.58	0.07	0.00
22.50	2.00	0.00	6.57	0.06	0.00	22.57	2.00	0.00	6.56	0.07	0.00
22.63	2.00	0.00	6.55	0.06	0.00	22.70	2.00	0.00	6.54	0.07	0.00
22.76	2.00	0.00	6.53	0.06	0.00	22.83	2.00	0.00	6.52	0.07	0.00
22.89	2.00	0.00	6.51	0.06	0.00	22.96	2.00	0.00	6.50	0.07	0.00
23.03	2.00	0.00	6.49	0.07	0.00	23.09	2.00	0.00	6.48	0.06	0.00
23.16	2.00	0.00	6.47	0.07	0.00	23.22	2.00	0.00	6.46	0.06	0.00
23.29	2.00	0.00	6.45	0.07	0.00	23.35	2.00	0.00	6.44	0.06	0.00
23.42	2.00	0.00	6.43	0.07	0.00	23.48	2.00	0.00	6.42	0.06	0.00
23.55	2.00	0.00	6.41	0.07	0.00	23.62	2.00	0.00	6.40	0.07	0.00
23.68	2.00	0.00	6.39	0.06	0.00	23.75	2.00	0.00	6.38	0.07	0.00
23.81	2.00	0.00	6.37	0.06	0.00	23.88	2.00	0.00	6.36	0.07	0.00
23.94	2.00	0.00	6.35	0.06	0.00	24.01	2.00	0.00	6.34	0.07	0.00
24.08	2.00	0.00	6.33	0.07	0.00	24.14	2.00	0.00	6.32	0.06	0.00
24.21	2.00	0.00	6.31	0.07	0.00	24.27	2.00	0.00	6.30	0.06	0.00
24.34	2.00	0.00	6.29	0.07	0.00	24.40	2.00	0.00	6.28	0.06	0.00
24.47	2.00	0.00	6.27	0.07	0.00	24.53	2.00	0.00	6.26	0.06	0.00
24.60	2.00	0.00	6.25	0.07	0.00	24.67	2.00	0.00	6.24	0.07	0.00
24.73	2.00	0.00	6.23	0.06	0.00	24.80	2.00	0.00	6.22	0.07	0.00
24.86	2.00	0.00	6.21	0.06	0.00	24.93	2.00	0.00	6.20	0.07	0.00
24.99	2.00	0.00	6.19	0.06	0.00	25.06	2.00	0.00	6.18	0.07	0.00
25.12	2.00	0.00	6.17	0.06	0.00	25.19	2.00	0.00	6.16	0.07	0.00

:: Liquefaction Potential Index calculation data :: (continued)											
Depth (ft)	FS	F _L	w _z	d _z	LPI	Depth (ft)	FS	F _L	w _z	d _z	LPI
25.26	2.00	0.00	6.15	0.07	0.00	25.32	2.00	0.00	6.14	0.06	0.00
25.39	2.00	0.00	6.13	0.07	0.00	25.45	2.00	0.00	6.12	0.06	0.00
25.52	2.00	0.00	6.11	0.07	0.00	25.58	2.00	0.00	6.10	0.06	0.00
25.65	2.00	0.00	6.09	0.07	0.00	25.72	2.00	0.00	6.08	0.07	0.00
25.78	2.00	0.00	6.07	0.06	0.00	25.85	2.00	0.00	6.06	0.07	0.00
25.91	2.00	0.00	6.05	0.06	0.00	25.98	2.00	0.00	6.04	0.07	0.00
26.04	2.00	0.00	6.03	0.06	0.00	26.11	2.00	0.00	6.02	0.07	0.00
26.17	2.00	0.00	6.01	0.06	0.00	26.24	2.00	0.00	6.00	0.07	0.00
26.31	2.00	0.00	5.99	0.07	0.00	26.37	2.00	0.00	5.98	0.06	0.00
26.44	2.00	0.00	5.97	0.07	0.00	26.50	2.00	0.00	5.96	0.06	0.00
26.57	2.00	0.00	5.95	0.07	0.00	26.63	2.00	0.00	5.94	0.06	0.00
26.70	2.00	0.00	5.93	0.07	0.00	26.76	2.00	0.00	5.92	0.06	0.00
26.83	2.00	0.00	5.91	0.07	0.00	26.90	2.00	0.00	5.90	0.07	0.00
26.96	2.00	0.00	5.89	0.06	0.00	27.03	2.00	0.00	5.88	0.07	0.00
27.09	2.00	0.00	5.87	0.06	0.00	27.16	2.00	0.00	5.86	0.07	0.00
27.22	2.00	0.00	5.85	0.06	0.00	27.29	2.00	0.00	5.84	0.07	0.00
27.36	2.00	0.00	5.83	0.07	0.00	27.42	2.00	0.00	5.82	0.06	0.00
27.49	2.00	0.00	5.81	0.07	0.00	27.55	2.00	0.00	5.80	0.06	0.00
27.62	2.00	0.00	5.79	0.07	0.00	27.68	2.00	0.00	5.78	0.06	0.00
27.75	2.00	0.00	5.77	0.07	0.00	27.81	2.00	0.00	5.76	0.06	0.00
27.88	2.00	0.00	5.75	0.07	0.00	27.95	2.00	0.00	5.74	0.07	0.00
28.01	2.00	0.00	5.73	0.06	0.00	28.08	2.00	0.00	5.72	0.07	0.00
28.14	2.00	0.00	5.71	0.06	0.00	28.21	2.00	0.00	5.70	0.07	0.00
28.27	2.00	0.00	5.69	0.06	0.00	28.34	2.00	0.00	5.68	0.07	0.00
28.40	2.00	0.00	5.67	0.06	0.00	28.47	2.00	0.00	5.66	0.07	0.00
28.54	2.00	0.00	5.65	0.07	0.00	28.60	2.00	0.00	5.64	0.06	0.00
28.67	2.00	0.00	5.63	0.07	0.00	28.73	2.00	0.00	5.62	0.06	0.00
28.80	2.00	0.00	5.61	0.07	0.00	28.86	2.00	0.00	5.60	0.06	0.00
28.93	2.00	0.00	5.59	0.07	0.00	29.00	2.00	0.00	5.58	0.07	0.00
29.06	2.00	0.00	5.57	0.06	0.00	29.13	2.00	0.00	5.56	0.07	0.00
29.19	2.00	0.00	5.55	0.06	0.00	29.26	2.00	0.00	5.54	0.07	0.00
29.32	2.00	0.00	5.53	0.06	0.00	29.39	2.00	0.00	5.52	0.07	0.00
29.45	2.00	0.00	5.51	0.06	0.00	29.52	2.00	0.00	5.50	0.07	0.00
29.59	2.00	0.00	5.49	0.07	0.00	29.65	2.00	0.00	5.48	0.06	0.00
29.72	2.00	0.00	5.47	0.07	0.00	29.78	2.00	0.00	5.46	0.06	0.00
29.85	2.00	0.00	5.45	0.07	0.00	29.91	2.00	0.00	5.44	0.06	0.00
29.98	2.00	0.00	5.43	0.07	0.00	30.04	2.00	0.00	5.42	0.06	0.00
30.11	2.00	0.00	5.41	0.07	0.00	30.18	2.00	0.00	5.40	0.07	0.00
30.24	2.00	0.00	5.39	0.06	0.00	30.31	2.00	0.00	5.38	0.07	0.00
30.37	2.00	0.00	5.37	0.06	0.00	30.44	2.00	0.00	5.36	0.07	0.00
30.50	2.00	0.00	5.35	0.06	0.00	30.57	2.00	0.00	5.34	0.07	0.00
30.64	2.00	0.00	5.33	0.07	0.00	30.70	2.00	0.00	5.32	0.06	0.00
30.77	2.00	0.00	5.31	0.07	0.00	30.83	2.00	0.00	5.30	0.06	0.00
30.90	2.00	0.00	5.29	0.07	0.00	30.96	2.00	0.00	5.28	0.06	0.00
31.03	2.00	0.00	5.27	0.07	0.00	31.09	2.00	0.00	5.26	0.06	0.00
31.16	2.00	0.00	5.25	0.07	0.00	31.23	2.00	0.00	5.24	0.07	0.00
31.29	2.00	0.00	5.23	0.06	0.00	31.36	2.00	0.00	5.22	0.07	0.00
31.42	2.00	0.00	5.21	0.06	0.00	31.49	2.00	0.00	5.20	0.07	0.00

:: Liquefaction Potential Index calculation data :: (continued)											
Depth (ft)	FS	F_L	w_z	d_z	LPI	Depth (ft)	FS	F_L	w_z	d_z	LPI
31.55	2.00	0.00	5.19	0.06	0.00	31.62	2.00	0.00	5.18	0.07	0.00
31.68	2.00	0.00	5.17	0.06	0.00	31.75	2.00	0.00	5.16	0.07	0.00
31.82	2.00	0.00	5.15	0.07	0.00	31.88	2.00	0.00	5.14	0.06	0.00
31.95	2.00	0.00	5.13	0.07	0.00	32.01	2.00	0.00	5.12	0.06	0.00
32.08	2.00	0.00	5.11	0.07	0.00	32.14	2.00	0.00	5.10	0.06	0.00
32.21	2.00	0.00	5.09	0.07	0.00	32.28	2.00	0.00	5.08	0.07	0.00
32.34	2.00	0.00	5.07	0.06	0.00	32.41	2.00	0.00	5.06	0.07	0.00
32.47	2.00	0.00	5.05	0.06	0.00	32.54	2.00	0.00	5.04	0.07	0.00
32.60	2.00	0.00	5.03	0.06	0.00	32.67	2.00	0.00	5.02	0.07	0.00
32.73	2.00	0.00	5.01	0.06	0.00	32.80	2.00	0.00	5.00	0.07	0.00
32.87	2.00	0.00	4.99	0.07	0.00	32.93	2.00	0.00	4.98	0.06	0.00
33.00	2.00	0.00	4.97	0.07	0.00	33.06	2.00	0.00	4.96	0.06	0.00
33.13	2.00	0.00	4.95	0.07	0.00	33.19	2.00	0.00	4.94	0.06	0.00
33.26	2.00	0.00	4.93	0.07	0.00	33.32	2.00	0.00	4.92	0.06	0.00
33.39	2.00	0.00	4.91	0.07	0.00	33.46	2.00	0.00	4.90	0.07	0.00
33.52	2.00	0.00	4.89	0.06	0.00	33.59	2.00	0.00	4.88	0.07	0.00
33.65	2.00	0.00	4.87	0.06	0.00	33.72	2.00	0.00	4.86	0.07	0.00
33.78	2.00	0.00	4.85	0.06	0.00	33.85	2.00	0.00	4.84	0.07	0.00
33.92	2.00	0.00	4.83	0.07	0.00	33.98	2.00	0.00	4.82	0.06	0.00
34.05	2.00	0.00	4.81	0.07	0.00	34.11	2.00	0.00	4.80	0.06	0.00
34.18	2.00	0.00	4.79	0.07	0.00	34.24	2.00	0.00	4.78	0.06	0.00
34.31	2.00	0.00	4.77	0.07	0.00	34.37	2.00	0.00	4.76	0.06	0.00
34.44	2.00	0.00	4.75	0.07	0.00	34.51	2.00	0.00	4.74	0.07	0.00
34.57	2.00	0.00	4.73	0.06	0.00	34.64	2.00	0.00	4.72	0.07	0.00
34.70	2.00	0.00	4.71	0.06	0.00	34.77	2.00	0.00	4.70	0.07	0.00
34.83	2.00	0.00	4.69	0.06	0.00	34.90	2.00	0.00	4.68	0.07	0.00
34.96	2.00	0.00	4.67	0.06	0.00	35.03	2.00	0.00	4.66	0.07	0.00
35.10	2.00	0.00	4.65	0.07	0.00	35.16	2.00	0.00	4.64	0.06	0.00
35.23	2.00	0.00	4.63	0.07	0.00	35.29	2.00	0.00	4.62	0.06	0.00
35.36	2.00	0.00	4.61	0.07	0.00	35.42	2.00	0.00	4.60	0.06	0.00
35.49	2.00	0.00	4.59	0.07	0.00	35.56	2.00	0.00	4.58	0.07	0.00
35.62	2.00	0.00	4.57	0.06	0.00	35.69	2.00	0.00	4.56	0.07	0.00
35.75	2.00	0.00	4.55	0.06	0.00	35.82	2.00	0.00	4.54	0.07	0.00
35.88	2.00	0.00	4.53	0.06	0.00	35.95	2.00	0.00	4.52	0.07	0.00
36.01	2.00	0.00	4.51	0.06	0.00	36.08	2.00	0.00	4.50	0.07	0.00
36.15	2.00	0.00	4.49	0.07	0.00	36.21	2.00	0.00	4.48	0.06	0.00
36.28	2.00	0.00	4.47	0.07	0.00	36.34	2.00	0.00	4.46	0.06	0.00
36.41	2.00	0.00	4.45	0.07	0.00	36.47	2.00	0.00	4.44	0.06	0.00
36.54	2.00	0.00	4.43	0.07	0.00	36.60	2.00	0.00	4.42	0.06	0.00
36.67	2.00	0.00	4.41	0.07	0.00	36.74	2.00	0.00	4.40	0.07	0.00
36.80	2.00	0.00	4.39	0.06	0.00	36.87	2.00	0.00	4.38	0.07	0.00
36.93	2.00	0.00	4.37	0.06	0.00	37.00	2.00	0.00	4.36	0.07	0.00
37.06	2.00	0.00	4.35	0.06	0.00	37.13	2.00	0.00	4.34	0.07	0.00
37.20	2.00	0.00	4.33	0.07	0.00	37.26	2.00	0.00	4.32	0.06	0.00
37.33	2.00	0.00	4.31	0.07	0.00	37.39	2.00	0.00	4.30	0.06	0.00
37.46	2.00	0.00	4.29	0.07	0.00	37.52	2.00	0.00	4.28	0.06	0.00
37.59	2.00	0.00	4.27	0.07	0.00	37.65	2.00	0.00	4.26	0.06	0.00
37.72	2.00	0.00	4.25	0.07	0.00	37.79	2.00	0.00	4.24	0.07	0.00

:: Liquefaction Potential Index calculation data :: (continued)											
Depth (ft)	FS	F _L	w _z	d _z	LPI	Depth (ft)	FS	F _L	w _z	d _z	LPI
37.85	2.00	0.00	4.23	0.06	0.00	37.92	2.00	0.00	4.22	0.07	0.00
37.98	2.00	0.00	4.21	0.06	0.00	38.05	2.00	0.00	4.20	0.07	0.00
38.11	2.00	0.00	4.19	0.06	0.00	38.18	2.00	0.00	4.18	0.07	0.00
38.24	2.00	0.00	4.17	0.06	0.00	38.31	2.00	0.00	4.16	0.07	0.00
38.38	2.00	0.00	4.15	0.07	0.00	38.44	2.00	0.00	4.14	0.06	0.00
38.51	2.00	0.00	4.13	0.07	0.00	38.57	2.00	0.00	4.12	0.06	0.00
38.64	2.00	0.00	4.11	0.07	0.00	38.70	2.00	0.00	4.10	0.06	0.00
38.77	2.00	0.00	4.09	0.07	0.00	38.84	2.00	0.00	4.08	0.07	0.00
38.90	2.00	0.00	4.07	0.06	0.00	38.97	2.00	0.00	4.06	0.07	0.00
39.03	2.00	0.00	4.05	0.06	0.00	39.10	2.00	0.00	4.04	0.07	0.00
39.16	2.00	0.00	4.03	0.06	0.00	39.23	2.00	0.00	4.02	0.07	0.00
39.29	2.00	0.00	4.01	0.06	0.00	39.36	2.00	0.00	4.00	0.07	0.00
39.43	2.00	0.00	3.99	0.07	0.00	39.49	2.00	0.00	3.98	0.06	0.00
39.56	2.00	0.00	3.97	0.07	0.00	39.62	2.00	0.00	3.96	0.06	0.00
39.69	2.00	0.00	3.95	0.07	0.00	39.75	2.00	0.00	3.94	0.06	0.00
39.82	2.00	0.00	3.93	0.07	0.00	39.88	2.00	0.00	3.92	0.06	0.00
39.95	2.00	0.00	3.91	0.07	0.00	40.02	2.00	0.00	3.90	0.07	0.00
40.08	2.00	0.00	3.89	0.06	0.00	40.15	2.00	0.00	3.88	0.07	0.00
40.21	2.00	0.00	3.87	0.06	0.00	40.28	2.00	0.00	3.86	0.07	0.00
40.34	2.00	0.00	3.85	0.06	0.00	40.41	2.00	0.00	3.84	0.07	0.00
40.48	2.00	0.00	3.83	0.07	0.00	40.54	2.00	0.00	3.82	0.06	0.00
40.61	2.00	0.00	3.81	0.07	0.00	40.67	2.00	0.00	3.80	0.06	0.00
40.74	2.00	0.00	3.79	0.07	0.00	40.80	2.00	0.00	3.78	0.06	0.00
40.87	2.00	0.00	3.77	0.07	0.00	40.93	2.00	0.00	3.76	0.06	0.00
41.00	2.00	0.00	3.75	0.07	0.00	41.07	2.00	0.00	3.74	0.07	0.00
41.13	2.00	0.00	3.73	0.06	0.00	41.20	2.00	0.00	3.72	0.07	0.00
41.26	2.00	0.00	3.71	0.06	0.00	41.33	2.00	0.00	3.70	0.07	0.00
41.39	2.00	0.00	3.69	0.06	0.00	41.46	2.00	0.00	3.68	0.07	0.00
41.52	2.00	0.00	3.67	0.06	0.00	41.59	2.00	0.00	3.66	0.07	0.00
41.66	2.00	0.00	3.65	0.07	0.00	41.72	2.00	0.00	3.64	0.06	0.00
41.79	2.00	0.00	3.63	0.07	0.00	41.85	2.00	0.00	3.62	0.06	0.00
41.92	2.00	0.00	3.61	0.07	0.00	41.98	2.00	0.00	3.60	0.06	0.00
42.05	2.00	0.00	3.59	0.07	0.00	42.12	2.00	0.00	3.58	0.07	0.00
42.18	2.00	0.00	3.57	0.06	0.00	42.25	2.00	0.00	3.56	0.07	0.00
42.31	2.00	0.00	3.55	0.06	0.00	42.38	2.00	0.00	3.54	0.07	0.00
42.44	2.00	0.00	3.53	0.06	0.00	42.51	2.00	0.00	3.52	0.07	0.00
42.57	2.00	0.00	3.51	0.06	0.00	42.64	2.00	0.00	3.50	0.07	0.00
42.71	2.00	0.00	3.49	0.07	0.00	42.77	2.00	0.00	3.48	0.06	0.00
42.84	2.00	0.00	3.47	0.07	0.00	42.90	2.00	0.00	3.46	0.06	0.00
42.97	2.00	0.00	3.45	0.07	0.00	43.03	2.00	0.00	3.44	0.06	0.00
43.10	2.00	0.00	3.43	0.07	0.00	43.16	2.00	0.00	3.42	0.06	0.00
43.23	2.00	0.00	3.41	0.07	0.00	43.30	2.00	0.00	3.40	0.07	0.00
43.36	2.00	0.00	3.39	0.06	0.00	43.43	2.00	0.00	3.38	0.07	0.00
43.49	2.00	0.00	3.37	0.06	0.00	43.56	2.00	0.00	3.36	0.07	0.00
43.62	2.00	0.00	3.35	0.06	0.00	43.69	2.00	0.00	3.34	0.07	0.00
43.76	2.00	0.00	3.33	0.07	0.00	43.82	2.00	0.00	3.32	0.06	0.00
43.89	2.00	0.00	3.31	0.07	0.00	43.95	2.00	0.00	3.30	0.06	0.00
44.02	2.00	0.00	3.29	0.07	0.00	44.08	2.00	0.00	3.28	0.06	0.00

:: Liquefaction Potential Index calculation data :: (continued)											
Depth (ft)	FS	F _L	w _z	d _z	LPI	Depth (ft)	FS	F _L	w _z	d _z	LPI
44.15	2.00	0.00	3.27	0.07	0.00	44.21	2.00	0.00	3.26	0.06	0.00
44.28	2.00	0.00	3.25	0.07	0.00	44.35	2.00	0.00	3.24	0.07	0.00
44.41	2.00	0.00	3.23	0.06	0.00	44.48	2.00	0.00	3.22	0.07	0.00
44.54	2.00	0.00	3.21	0.06	0.00	44.61	2.00	0.00	3.20	0.07	0.00
44.67	2.00	0.00	3.19	0.06	0.00	44.74	2.00	0.00	3.18	0.07	0.00
44.80	2.00	0.00	3.17	0.06	0.00	44.87	2.00	0.00	3.16	0.07	0.00
44.94	2.00	0.00	3.15	0.07	0.00	45.00	2.00	0.00	3.14	0.06	0.00
45.07	2.00	0.00	3.13	0.07	0.00	45.13	2.00	0.00	3.12	0.06	0.00
45.20	2.00	0.00	3.11	0.07	0.00	45.26	2.00	0.00	3.10	0.06	0.00
45.33	2.00	0.00	3.09	0.07	0.00	45.40	2.00	0.00	3.08	0.07	0.00
45.46	2.00	0.00	3.07	0.06	0.00	45.53	2.00	0.00	3.06	0.07	0.00
45.59	2.00	0.00	3.05	0.06	0.00	45.66	2.00	0.00	3.04	0.07	0.00
45.72	2.00	0.00	3.03	0.06	0.00	45.79	2.00	0.00	3.02	0.07	0.00
45.85	2.00	0.00	3.01	0.06	0.00	45.92	2.00	0.00	3.00	0.07	0.00
45.99	2.00	0.00	2.99	0.07	0.00	46.05	2.00	0.00	2.98	0.06	0.00
46.12	2.00	0.00	2.97	0.07	0.00	46.18	2.00	0.00	2.96	0.06	0.00
46.25	2.00	0.00	2.95	0.07	0.00	46.31	2.00	0.00	2.94	0.06	0.00
46.38	2.00	0.00	2.93	0.07	0.00	46.45	2.00	0.00	2.92	0.07	0.00
46.51	2.00	0.00	2.91	0.06	0.00	46.58	2.00	0.00	2.90	0.07	0.00
46.64	2.00	0.00	2.89	0.06	0.00	46.71	2.00	0.00	2.88	0.07	0.00
46.77	2.00	0.00	2.87	0.06	0.00	46.84	2.00	0.00	2.86	0.07	0.00
46.90	2.00	0.00	2.85	0.06	0.00	46.97	2.00	0.00	2.84	0.07	0.00
47.04	2.00	0.00	2.83	0.07	0.00	47.10	2.00	0.00	2.82	0.06	0.00
47.17	2.00	0.00	2.81	0.07	0.00	47.23	2.00	0.00	2.80	0.06	0.00
47.30	2.00	0.00	2.79	0.07	0.00	47.36	2.00	0.00	2.78	0.06	0.00
47.43	2.00	0.00	2.77	0.07	0.00	47.49	2.00	0.00	2.76	0.06	0.00
47.56	2.00	0.00	2.75	0.07	0.00	47.63	2.00	0.00	2.74	0.07	0.00
47.69	2.00	0.00	2.73	0.06	0.00	47.76	2.00	0.00	2.72	0.07	0.00
47.82	2.00	0.00	2.71	0.06	0.00	47.89	2.00	0.00	2.70	0.07	0.00
47.95	2.00	0.00	2.69	0.06	0.00	48.02	2.00	0.00	2.68	0.07	0.00
48.09	2.00	0.00	2.67	0.07	0.00	48.15	2.00	0.00	2.66	0.06	0.00
48.22	2.00	0.00	2.65	0.07	0.00	48.28	2.00	0.00	2.64	0.06	0.00
48.35	2.00	0.00	2.63	0.07	0.00	48.41	2.00	0.00	2.62	0.06	0.00
48.48	2.00	0.00	2.61	0.07	0.00	48.54	2.00	0.00	2.60	0.06	0.00
48.61	2.00	0.00	2.59	0.07	0.00	48.68	2.00	0.00	2.58	0.07	0.00
48.74	2.00	0.00	2.57	0.06	0.00	48.81	2.00	0.00	2.56	0.07	0.00
48.87	2.00	0.00	2.55	0.06	0.00	48.94	2.00	0.00	2.54	0.07	0.00
49.00	2.00	0.00	2.53	0.06	0.00	49.07	2.00	0.00	2.52	0.07	0.00
49.13	2.00	0.00	2.51	0.06	0.00	49.20	2.00	0.00	2.50	0.07	0.00
49.27	2.00	0.00	2.49	0.07	0.00	49.33	2.00	0.00	2.48	0.06	0.00
49.40	2.00	0.00	2.47	0.07	0.00	49.46	2.00	0.00	2.46	0.06	0.00
49.53	2.00	0.00	2.45	0.07	0.00	49.59	2.00	0.00	2.44	0.06	0.00
49.66	2.00	0.00	2.43	0.07	0.00	49.73	2.00	0.00	2.42	0.07	0.00
49.79	2.00	0.00	2.41	0.06	0.00	49.86	2.00	0.00	2.40	0.07	0.00
49.92	2.00	0.00	2.39	0.06	0.00	49.99	2.00	0.00	2.38	0.07	0.00
50.05	2.00	0.00	2.37	0.06	0.00	50.12	2.00	0.00	2.36	0.07	0.00
50.18	2.00	0.00	2.35	0.06	0.00	50.25	2.00	0.00	2.34	0.07	0.00
50.32	2.00	0.00	2.33	0.07	0.00	50.38	2.00	0.00	2.32	0.06	0.00

:: Liquefaction Potential Index calculation data :: (continued)											
Depth (ft)	FS	F_L	w_z	d_z	LPI	Depth (ft)	FS	F_L	w_z	d_z	LPI
50.45	2.00	0.00	2.31	0.07	0.00	50.51	2.00	0.00	2.30	0.06	0.00
50.58	2.00	0.00	2.29	0.07	0.00	50.64	2.00	0.00	2.28	0.06	0.00
50.71	2.00	0.00	2.27	0.07	0.00	50.77	2.00	0.00	2.26	0.06	0.00
50.84	2.00	0.00	2.25	0.07	0.00	50.91	2.00	0.00	2.24	0.07	0.00
50.97	2.00	0.00	2.23	0.06	0.00	51.04	2.00	0.00	2.22	0.07	0.00
51.10	2.00	0.00	2.21	0.06	0.00	51.17	2.00	0.00	2.20	0.07	0.00
51.23	2.00	0.00	2.19	0.06	0.00	51.30	2.00	0.00	2.18	0.07	0.00
51.37	2.00	0.00	2.17	0.07	0.00	51.43	2.00	0.00	2.16	0.06	0.00
51.50	2.00	0.00	2.15	0.07	0.00	51.56	2.00	0.00	2.14	0.06	0.00
51.63	2.00	0.00	2.13	0.07	0.00	51.69	2.00	0.00	2.12	0.06	0.00
51.76	2.00	0.00	2.11	0.07	0.00	51.82	2.00	0.00	2.10	0.06	0.00
51.89	2.00	0.00	2.09	0.07	0.00	51.96	2.00	0.00	2.08	0.07	0.00
52.02	2.00	0.00	2.07	0.06	0.00	52.09	2.00	0.00	2.06	0.07	0.00
52.15	2.00	0.00	2.05	0.06	0.00	52.22	2.00	0.00	2.04	0.07	0.00
52.28	2.00	0.00	2.03	0.06	0.00	52.35	2.00	0.00	2.02	0.07	0.00
52.41	2.00	0.00	2.01	0.06	0.00	52.48	2.00	0.00	2.00	0.07	0.00
52.55	2.00	0.00	1.99	0.07	0.00	52.61	2.00	0.00	1.98	0.06	0.00
52.68	2.00	0.00	1.97	0.07	0.00	52.74	2.00	0.00	1.96	0.06	0.00
52.81	2.00	0.00	1.95	0.07	0.00	52.87	2.00	0.00	1.94	0.06	0.00
52.94	2.00	0.00	1.93	0.07	0.00	53.01	2.00	0.00	1.92	0.07	0.00
53.07	2.00	0.00	1.91	0.06	0.00	53.14	2.00	0.00	1.90	0.07	0.00
53.20	2.00	0.00	1.89	0.06	0.00	53.27	2.00	0.00	1.88	0.07	0.00
53.33	2.00	0.00	1.87	0.06	0.00	53.40	2.00	0.00	1.86	0.07	0.00
53.46	2.00	0.00	1.85	0.06	0.00	53.53	2.00	0.00	1.84	0.07	0.00
53.60	2.00	0.00	1.83	0.07	0.00	53.66	2.00	0.00	1.82	0.06	0.00
53.73	2.00	0.00	1.81	0.07	0.00	53.79	2.00	0.00	1.80	0.06	0.00
53.86	2.00	0.00	1.79	0.07	0.00	53.92	2.00	0.00	1.78	0.06	0.00
53.99	2.00	0.00	1.77	0.07	0.00	54.05	2.00	0.00	1.76	0.06	0.00
54.12	2.00	0.00	1.75	0.07	0.00	54.19	2.00	0.00	1.74	0.07	0.00
54.25	2.00	0.00	1.73	0.06	0.00	54.32	2.00	0.00	1.72	0.07	0.00
54.38	2.00	0.00	1.71	0.06	0.00	54.45	2.00	0.00	1.70	0.07	0.00
54.51	2.00	0.00	1.69	0.06	0.00	54.58	2.00	0.00	1.68	0.07	0.00
54.65	2.00	0.00	1.67	0.07	0.00	54.71	2.00	0.00	1.66	0.06	0.00
54.78	2.00	0.00	1.65	0.07	0.00	54.84	2.00	0.00	1.64	0.06	0.00
54.91	2.00	0.00	1.63	0.07	0.00	54.97	2.00	0.00	1.62	0.06	0.00
55.04	2.00	0.00	1.61	0.07	0.00	55.10	2.00	0.00	1.60	0.06	0.00
55.17	2.00	0.00	1.59	0.07	0.00	55.24	2.00	0.00	1.58	0.07	0.00
55.30	2.00	0.00	1.57	0.06	0.00	55.37	2.00	0.00	1.56	0.07	0.00
55.43	2.00	0.00	1.55	0.06	0.00	55.50	2.00	0.00	1.54	0.07	0.00
55.56	2.00	0.00	1.53	0.06	0.00	55.63	2.00	0.00	1.52	0.07	0.00
55.69	2.00	0.00	1.51	0.06	0.00	55.76	2.00	0.00	1.50	0.07	0.00
55.83	2.00	0.00	1.49	0.07	0.00	55.89	2.00	0.00	1.48	0.06	0.00
55.96	2.00	0.00	1.47	0.07	0.00	56.02	2.00	0.00	1.46	0.06	0.00
56.09	2.00	0.00	1.45	0.07	0.00	56.15	2.00	0.00	1.44	0.06	0.00
56.22	2.00	0.00	1.43	0.07	0.00	56.29	2.00	0.00	1.42	0.07	0.00
56.35	2.00	0.00	1.41	0.06	0.00	56.42	2.00	0.00	1.40	0.07	0.00
56.48	2.00	0.00	1.39	0.06	0.00	56.55	2.00	0.00	1.38	0.07	0.00
56.61	2.00	0.00	1.37	0.06	0.00	56.68	2.00	0.00	1.36	0.07	0.00

:: Liquefaction Potential Index calculation data :: (continued)											
Depth (ft)	FS	F _L	w _z	d _z	LPI	Depth (ft)	FS	F _L	w _z	d _z	LPI
56.74	2.00	0.00	1.35	0.06	0.00	56.81	2.00	0.00	1.34	0.07	0.00
56.88	2.00	0.00	1.33	0.07	0.00	56.94	2.00	0.00	1.32	0.06	0.00
57.01	2.00	0.00	1.31	0.07	0.00	57.07	2.00	0.00	1.30	0.06	0.00
57.14	2.00	0.00	1.29	0.07	0.00	57.20	2.00	0.00	1.28	0.06	0.00
57.27	2.00	0.00	1.27	0.07	0.00	57.33	2.00	0.00	1.26	0.06	0.00
57.40	2.00	0.00	1.25	0.07	0.00	57.47	2.00	0.00	1.24	0.07	0.00
57.53	2.00	0.00	1.23	0.06	0.00	57.60	2.00	0.00	1.22	0.07	0.00
57.66	2.00	0.00	1.21	0.06	0.00	57.73	2.00	0.00	1.20	0.07	0.00
57.79	2.00	0.00	1.19	0.06	0.00	57.86	2.00	0.00	1.18	0.07	0.00
57.93	2.00	0.00	1.17	0.07	0.00	57.99	2.00	0.00	1.16	0.06	0.00
58.06	2.00	0.00	1.15	0.07	0.00	58.12	2.00	0.00	1.14	0.06	0.00
58.19	2.00	0.00	1.13	0.07	0.00	58.25	2.00	0.00	1.12	0.06	0.00
58.32	2.00	0.00	1.11	0.07	0.00	58.38	2.00	0.00	1.10	0.06	0.00
58.45	2.00	0.00	1.09	0.07	0.00	58.52	2.00	0.00	1.08	0.07	0.00
58.58	2.00	0.00	1.07	0.06	0.00	58.65	2.00	0.00	1.06	0.07	0.00
58.71	2.00	0.00	1.05	0.06	0.00	58.78	2.00	0.00	1.04	0.07	0.00
58.84	2.00	0.00	1.03	0.06	0.00	58.91	2.00	0.00	1.02	0.07	0.00
58.97	2.00	0.00	1.01	0.06	0.00	59.04	2.00	0.00	1.00	0.07	0.00
59.11	2.00	0.00	0.99	0.07	0.00	59.17	2.00	0.00	0.98	0.06	0.00
59.24	2.00	0.00	0.97	0.07	0.00	59.30	2.00	0.00	0.96	0.06	0.00
59.37	2.00	0.00	0.95	0.07	0.00	59.43	2.00	0.00	0.94	0.06	0.00
59.50	2.00	0.00	0.93	0.07	0.00	59.57	2.00	0.00	0.92	0.07	0.00
59.63	2.00	0.00	0.91	0.06	0.00	59.70	2.00	0.00	0.90	0.07	0.00
59.76	2.00	0.00	0.89	0.06	0.00	59.83	2.00	0.00	0.88	0.07	0.00
59.89	2.00	0.00	0.87	0.06	0.00	59.96	2.00	0.00	0.86	0.07	0.00
60.02	2.00	0.00	0.85	0.06	0.00	60.09	2.00	0.00	0.84	0.07	0.00
60.16	2.00	0.00	0.83	0.07	0.00	60.22	2.00	0.00	0.82	0.06	0.00
60.29	2.00	0.00	0.81	0.07	0.00	60.35	2.00	0.00	0.80	0.06	0.00
60.42	2.00	0.00	0.79	0.07	0.00	60.48	2.00	0.00	0.78	0.06	0.00
60.55	2.00	0.00	0.77	0.07	0.00	60.61	2.00	0.00	0.76	0.06	0.00
60.68	2.00	0.00	0.75	0.07	0.00	60.75	2.00	0.00	0.74	0.07	0.00
60.81	2.00	0.00	0.73	0.06	0.00	60.88	2.00	0.00	0.72	0.07	0.00
60.94	2.00	0.00	0.71	0.06	0.00	61.01	2.00	0.00	0.70	0.07	0.00
61.07	2.00	0.00	0.69	0.06	0.00	61.14	2.00	0.00	0.68	0.07	0.00
61.21	2.00	0.00	0.67	0.07	0.00	61.27	2.00	0.00	0.66	0.06	0.00
61.34	2.00	0.00	0.65	0.07	0.00	61.40	2.00	0.00	0.64	0.06	0.00
61.47	2.00	0.00	0.63	0.07	0.00	61.53	2.00	0.00	0.62	0.06	0.00
61.60	2.00	0.00	0.61	0.07	0.00	61.66	2.00	0.00	0.60	0.06	0.00
61.73	2.00	0.00	0.59	0.07	0.00	61.80	2.00	0.00	0.58	0.07	0.00
61.86	2.00	0.00	0.57	0.06	0.00	61.93	2.00	0.00	0.56	0.07	0.00
61.99	2.00	0.00	0.55	0.06	0.00	62.06	2.00	0.00	0.54	0.07	0.00
62.12	2.00	0.00	0.53	0.06	0.00	62.19	2.00	0.00	0.52	0.07	0.00
62.25	2.00	0.00	0.51	0.06	0.00	62.32	2.00	0.00	0.50	0.07	0.00
62.39	2.00	0.00	0.49	0.07	0.00	62.45	2.00	0.00	0.48	0.06	0.00
62.52	2.00	0.00	0.47	0.07	0.00	62.58	2.00	0.00	0.46	0.06	0.00
62.65	2.00	0.00	0.45	0.07	0.00	62.71	2.00	0.00	0.44	0.06	0.00
62.78	2.00	0.00	0.43	0.07	0.00	62.85	2.00	0.00	0.42	0.07	0.00
62.91	2.00	0.00	0.41	0.06	0.00	62.98	2.00	0.00	0.40	0.07	0.00

:: Liquefaction Potential Index calculation data :: (continued)											
Depth (ft)	FS	F _L	w _z	d _z	LPI	Depth (ft)	FS	F _L	w _z	d _z	LPI
63.04	2.00	0.00	0.39	0.06	0.00	63.11	2.00	0.00	0.38	0.07	0.00
63.17	2.00	0.00	0.37	0.06	0.00	63.24	2.00	0.00	0.36	0.07	0.00
63.30	2.00	0.00	0.35	0.06	0.00	63.37	2.00	0.00	0.34	0.07	0.00
63.44	2.00	0.00	0.33	0.07	0.00	63.50	2.00	0.00	0.32	0.06	0.00
63.57	2.00	0.00	0.31	0.07	0.00	63.63	2.00	0.00	0.30	0.06	0.00
63.70	2.00	0.00	0.29	0.07	0.00	63.76	2.00	0.00	0.28	0.06	0.00
63.83	2.00	0.00	0.27	0.07	0.00	63.89	2.00	0.00	0.26	0.06	0.00
63.96	2.00	0.00	0.25	0.07	0.00	64.03	2.00	0.00	0.24	0.07	0.00
64.09	2.00	0.00	0.23	0.06	0.00	64.16	2.00	0.00	0.22	0.07	0.00
64.22	2.00	0.00	0.21	0.06	0.00	64.29	2.00	0.00	0.20	0.07	0.00
64.35	2.00	0.00	0.19	0.06	0.00	64.42	2.00	0.00	0.18	0.07	0.00
64.49	2.00	0.00	0.17	0.07	0.00	64.55	2.00	0.00	0.16	0.06	0.00
64.62	2.00	0.00	0.15	0.07	0.00	64.68	2.00	0.00	0.14	0.06	0.00
64.75	2.00	0.00	0.13	0.07	0.00	64.81	2.00	0.00	0.12	0.06	0.00
64.88	2.00	0.00	0.11	0.07	0.00	64.94	2.00	0.00	0.10	0.06	0.00
65.01	2.00	0.00	0.09	0.07	0.00	65.08	2.00	0.00	0.08	0.07	0.00
65.14	2.00	0.00	0.07	0.06	0.00	65.21	2.00	0.00	0.06	0.07	0.00
65.27	2.00	0.00	0.05	0.06	0.00	65.34	2.00	0.00	0.04	0.07	0.00
65.40	2.00	0.00	0.03	0.06	0.00	65.47	2.00	0.00	0.02	0.07	0.00
65.53	2.00	0.00	0.01	0.06	0.00	65.60	2.00	0.00	0.00	0.07	0.00
65.67	2.00	0.00	0.00	0.00	0.00	65.73	2.00	0.00	0.00	0.00	0.00
65.80	2.00	0.00	0.00	0.00	0.00	65.86	2.00	0.00	0.00	0.00	0.00
65.93	2.00	0.00	0.00	0.00	0.00	65.99	2.00	0.00	0.00	0.00	0.00
66.06	2.00	0.00	0.00	0.00	0.00	66.13	2.00	0.00	0.00	0.00	0.00
66.19	2.00	0.00	0.00	0.00	0.00	66.26	2.00	0.00	0.00	0.00	0.00
66.32	2.00	0.00	0.00	0.00	0.00	66.39	2.00	0.00	0.00	0.00	0.00
66.45	2.00	0.00	0.00	0.00	0.00	66.52	2.00	0.00	0.00	0.00	0.00
66.58	2.00	0.00	0.00	0.00	0.00	66.65	2.00	0.00	0.00	0.00	0.00
66.72	2.00	0.00	0.00	0.00	0.00	66.78	2.00	0.00	0.00	0.00	0.00
66.85	2.00	0.00	0.00	0.00	0.00	66.91	2.00	0.00	0.00	0.00	0.00
66.98	2.00	0.00	0.00	0.00	0.00	67.04	2.00	0.00	0.00	0.00	0.00
67.11	2.00	0.00	0.00	0.00	0.00	67.17	2.00	0.00	0.00	0.00	0.00
67.24	2.00	0.00	0.00	0.00	0.00	67.31	2.00	0.00	0.00	0.00	0.00
67.37	2.00	0.00	0.00	0.00	0.00	67.44	2.00	0.00	0.00	0.00	0.00
67.50	2.00	0.00	0.00	0.00	0.00	67.57	2.00	0.00	0.00	0.00	0.00
67.63	2.00	0.00	0.00	0.00	0.00	67.70	2.00	0.00	0.00	0.00	0.00
67.77	2.00	0.00	0.00	0.00	0.00	67.83	2.00	0.00	0.00	0.00	0.00
67.90	2.00	0.00	0.00	0.00	0.00	67.96	2.00	0.00	0.00	0.00	0.00
68.03	2.00	0.00	0.00	0.00	0.00	68.09	2.00	0.00	0.00	0.00	0.00
68.16	2.00	0.00	0.00	0.00	0.00	68.22	2.00	0.00	0.00	0.00	0.00
68.29	2.00	0.00	0.00	0.00	0.00	68.36	2.00	0.00	0.00	0.00	0.00
68.42	2.00	0.00	0.00	0.00	0.00	68.49	2.00	0.00	0.00	0.00	0.00
68.55	2.00	0.00	0.00	0.00	0.00	68.62	2.00	0.00	0.00	0.00	0.00
68.68	2.00	0.00	0.00	0.00	0.00	68.75	2.00	0.00	0.00	0.00	0.00
68.81	2.00	0.00	0.00	0.00	0.00	68.88	2.00	0.00	0.00	0.00	0.00
68.95	2.00	0.00	0.00	0.00	0.00	69.01	2.00	0.00	0.00	0.00	0.00
69.08	2.00	0.00	0.00	0.00	0.00	69.14	2.00	0.00	0.00	0.00	0.00
69.21	2.00	0.00	0.00	0.00	0.00	69.27	2.00	0.00	0.00	0.00	0.00

:: Liquefaction Potential Index calculation data :: (continued)											
Depth (ft)	FS	F _L	w _z	d _z	LPI	Depth (ft)	FS	F _L	w _z	d _z	LPI
69.34	2.00	0.00	0.00	0.00	0.00	69.41	2.00	0.00	0.00	0.00	0.00
69.47	2.00	0.00	0.00	0.00	0.00	69.54	2.00	0.00	0.00	0.00	0.00
69.60	2.00	0.00	0.00	0.00	0.00	69.67	2.00	0.00	0.00	0.00	0.00
69.73	2.00	0.00	0.00	0.00	0.00	69.80	2.00	0.00	0.00	0.00	0.00
69.86	2.00	0.00	0.00	0.00	0.00	69.93	2.00	0.00	0.00	0.00	0.00
70.00	2.00	0.00	0.00	0.00	0.00	70.06	2.00	0.00	0.00	0.00	0.00
70.13	2.00	0.00	0.00	0.00	0.00	70.19	2.00	0.00	0.00	0.00	0.00
70.26	2.00	0.00	0.00	0.00	0.00	70.32	2.00	0.00	0.00	0.00	0.00
70.39	2.00	0.00	0.00	0.00	0.00	70.45	2.00	0.00	0.00	0.00	0.00
70.52	2.00	0.00	0.00	0.00	0.00	70.59	2.00	0.00	0.00	0.00	0.00
70.65	2.00	0.00	0.00	0.00	0.00	70.72	2.00	0.00	0.00	0.00	0.00
70.78	2.00	0.00	0.00	0.00	0.00	70.85	2.00	0.00	0.00	0.00	0.00
70.91	2.00	0.00	0.00	0.00	0.00	70.98	2.00	0.00	0.00	0.00	0.00
71.05	2.00	0.00	0.00	0.00	0.00	71.11	2.00	0.00	0.00	0.00	0.00
71.18	2.00	0.00	0.00	0.00	0.00	71.24	2.00	0.00	0.00	0.00	0.00
71.31	2.00	0.00	0.00	0.00	0.00	71.37	2.00	0.00	0.00	0.00	0.00
71.44	2.00	0.00	0.00	0.00	0.00	71.50	2.00	0.00	0.00	0.00	0.00
71.57	2.00	0.00	0.00	0.00	0.00	71.64	2.00	0.00	0.00	0.00	0.00
71.70	2.00	0.00	0.00	0.00	0.00	71.77	2.00	0.00	0.00	0.00	0.00
71.83	2.00	0.00	0.00	0.00	0.00	71.90	2.00	0.00	0.00	0.00	0.00
71.96	2.00	0.00	0.00	0.00	0.00	72.03	2.00	0.00	0.00	0.00	0.00
72.09	2.00	0.00	0.00	0.00	0.00	72.16	2.00	0.00	0.00	0.00	0.00
72.23	2.00	0.00	0.00	0.00	0.00	72.29	2.00	0.00	0.00	0.00	0.00
72.36	2.00	0.00	0.00	0.00	0.00	72.42	2.00	0.00	0.00	0.00	0.00
72.49	2.00	0.00	0.00	0.00	0.00	72.55	2.00	0.00	0.00	0.00	0.00
72.62	2.00	0.00	0.00	0.00	0.00	72.69	2.00	0.00	0.00	0.00	0.00
72.75	2.00	0.00	0.00	0.00	0.00	72.82	2.00	0.00	0.00	0.00	0.00
72.88	2.00	0.00	0.00	0.00	0.00	72.95	2.00	0.00	0.00	0.00	0.00
73.01	2.00	0.00	0.00	0.00	0.00	73.08	2.00	0.00	0.00	0.00	0.00
73.14	2.00	0.00	0.00	0.00	0.00	73.21	2.00	0.00	0.00	0.00	0.00
73.28	2.00	0.00	0.00	0.00	0.00	73.34	2.00	0.00	0.00	0.00	0.00
73.41	2.00	0.00	0.00	0.00	0.00	73.47	2.00	0.00	0.00	0.00	0.00
73.54	2.00	0.00	0.00	0.00	0.00	73.60	2.00	0.00	0.00	0.00	0.00
73.67	2.00	0.00	0.00	0.00	0.00	73.73	2.00	0.00	0.00	0.00	0.00
73.80	2.00	0.00	0.00	0.00	0.00	73.87	2.00	0.00	0.00	0.00	0.00
73.93	2.00	0.00	0.00	0.00	0.00	74.00	2.00	0.00	0.00	0.00	0.00
74.06	2.00	0.00	0.00	0.00	0.00	74.13	2.00	0.00	0.00	0.00	0.00
74.19	2.00	0.00	0.00	0.00	0.00	74.26	2.00	0.00	0.00	0.00	0.00
74.32	2.00	0.00	0.00	0.00	0.00	74.39	2.00	0.00	0.00	0.00	0.00
74.46	2.00	0.00	0.00	0.00	0.00	74.52	2.00	0.00	0.00	0.00	0.00
74.59	2.00	0.00	0.00	0.00	0.00	74.65	2.00	0.00	0.00	0.00	0.00
74.72	2.00	0.00	0.00	0.00	0.00	74.78	2.00	0.00	0.00	0.00	0.00
74.85	2.00	0.00	0.00	0.00	0.00	74.92	2.00	0.00	0.00	0.00	0.00
74.98	2.00	0.00	0.00	0.00	0.00	75.05	2.00	0.00	0.00	0.00	0.00
75.11	2.00	0.00	0.00	0.00	0.00	75.18	2.00	0.00	0.00	0.00	0.00
75.24	2.00	0.00	0.00	0.00	0.00	75.31	2.00	0.00	0.00	0.00	0.00
75.37	2.00	0.00	0.00	0.00	0.00	75.44	2.00	0.00	0.00	0.00	0.00
75.51	2.00	0.00	0.00	0.00	0.00						

:: Liquefaction Potential Index calculation data :: (continued)											
Depth (ft)	FS	F_L	w_z	d_z	LPI	Depth (ft)	FS	F_L	w_z	d_z	LPI

Overall liquefaction potential: 0.00

LPI = 0.00 - Liquefaction risk very low
 LPI between 0.00 and 5.00 - Liquefaction risk low
 LPI between 5.00 and 15.00 - Liquefaction risk high
 LPI > 15.00 - Liquefaction risk very high

Abbreviations

FS: Calculated factor of safety for test point
 F_L : 1 - FS
 w_z : Function value of the extend of soil liquefaction according to depth
 d_z : Layer thickness (ft)
 LPI: Liquefaction potential index value for test point



Procedure for the evaluation of soil liquefaction resistance, NCEER (1998)

Calculation of soil resistance against liquefaction is performed according to the Robertson & Wride (1998) procedure. The procedure used in the software, slightly differs from the one originally published in NCEER-97-0022 (Proceedings of the NCEER Workshop on Evaluation of Liquefaction Resistance of Soils). The revised procedure is presented below in the form of a flowchart¹:

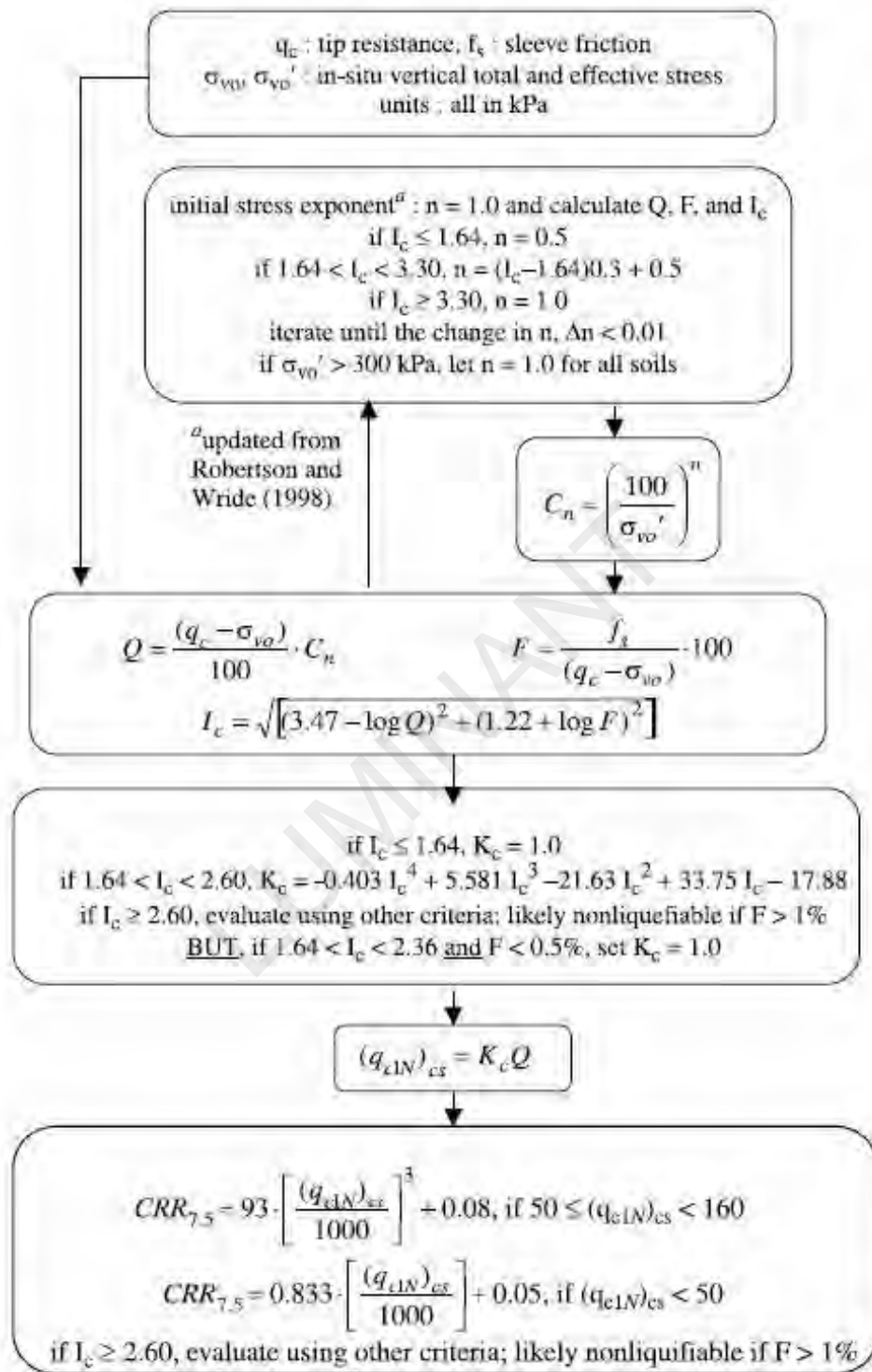

¹ "Estimating liquefaction-induced ground settlements from CPT for level ground", G. Zhang, P.K. Robertson, and R.W.I. Brachman

Procedure for the evaluation of soil liquefaction resistance (all soils), Robertson (2010)

Calculation of soil resistance against liquefaction is performed according to the Robertson & Wride (1998) procedure. This procedure used in the software, slightly differs from the one originally published in NCEER-97-0022 (Proceedings of the NCEER Workshop on Evaluation of Liquefaction Resistance of Soils). The revised procedure is presented below in the form of a flowchart¹:

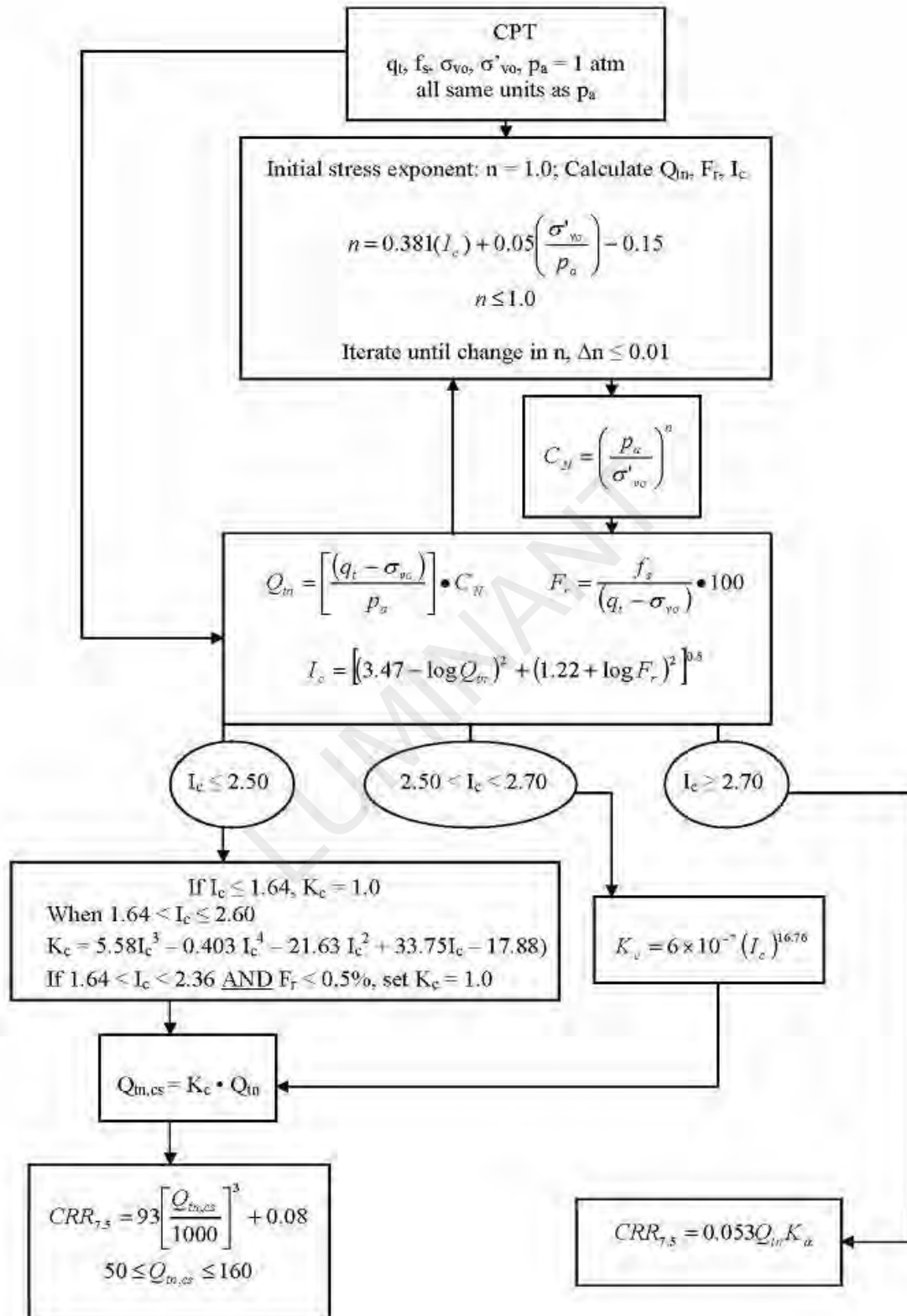

¹ P.K. Robertson, 2009. "Performance based earthquake design using the CPT", Keynote Lecture, International Conference on Performance-based Design in Earthquake Geotechnical Engineering – from case history to practice, IS-Tokyo, June 2009

Procedure for the evaluation of soil liquefaction resistance, Idriss & Boulanger (2008)

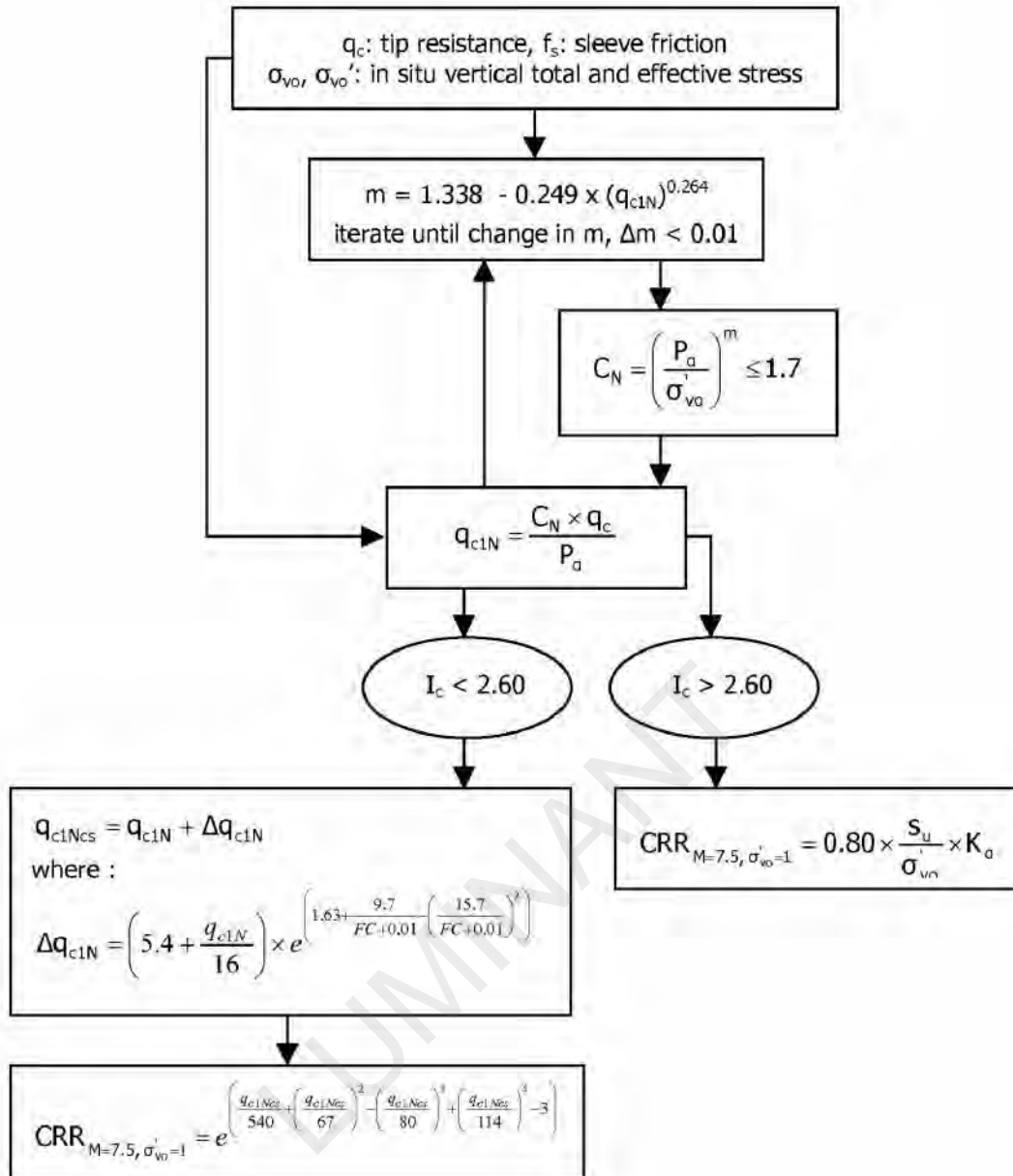

Procedure for the evaluation of soil liquefaction resistance (sandy soils), Moss et al. (2006)

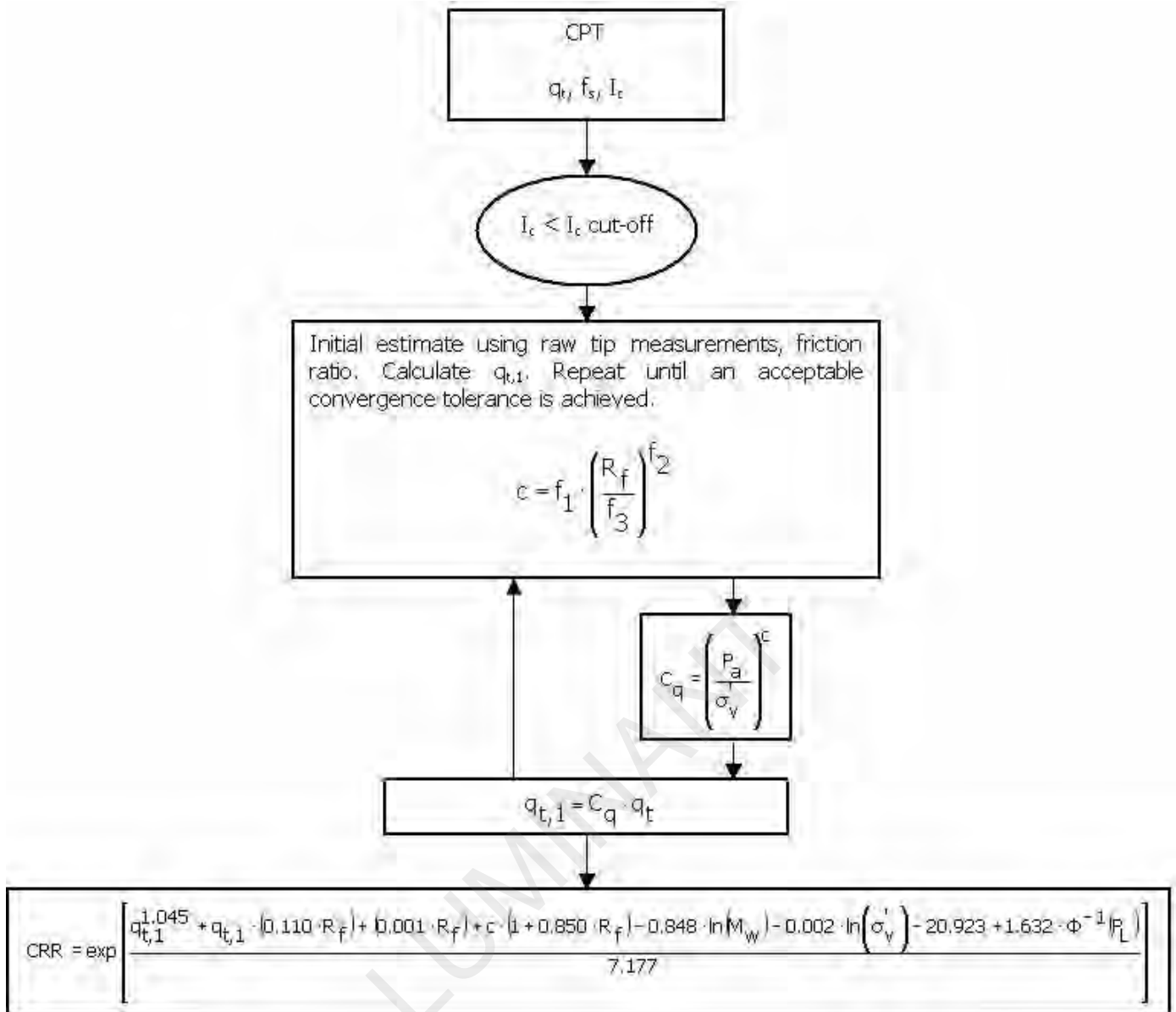

Procedure for the evaluation of soil liquefaction resistance, Boulanger & Idriss(2014)

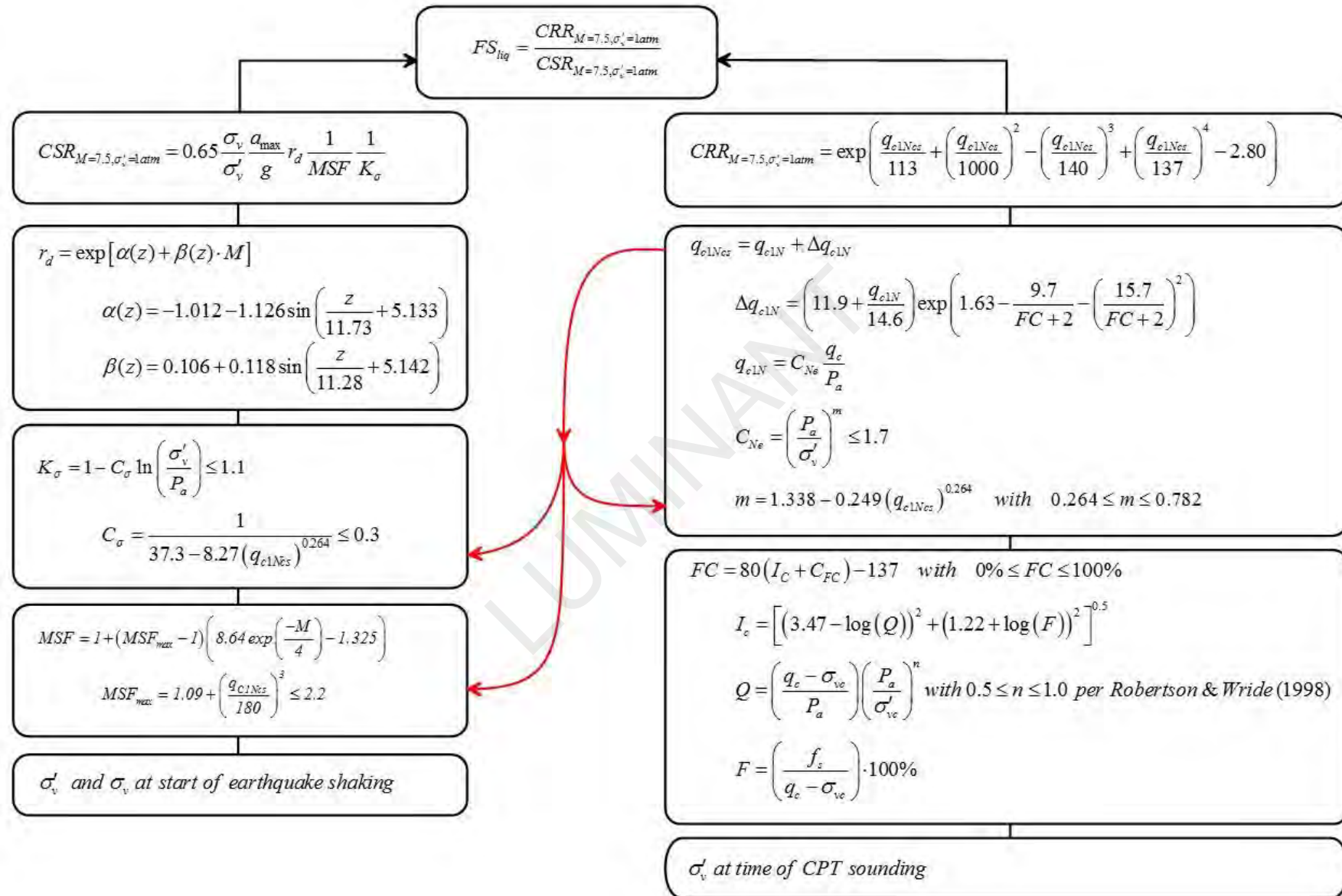

Procedure for the evaluation of liquefaction-induced lateral spreading displacements

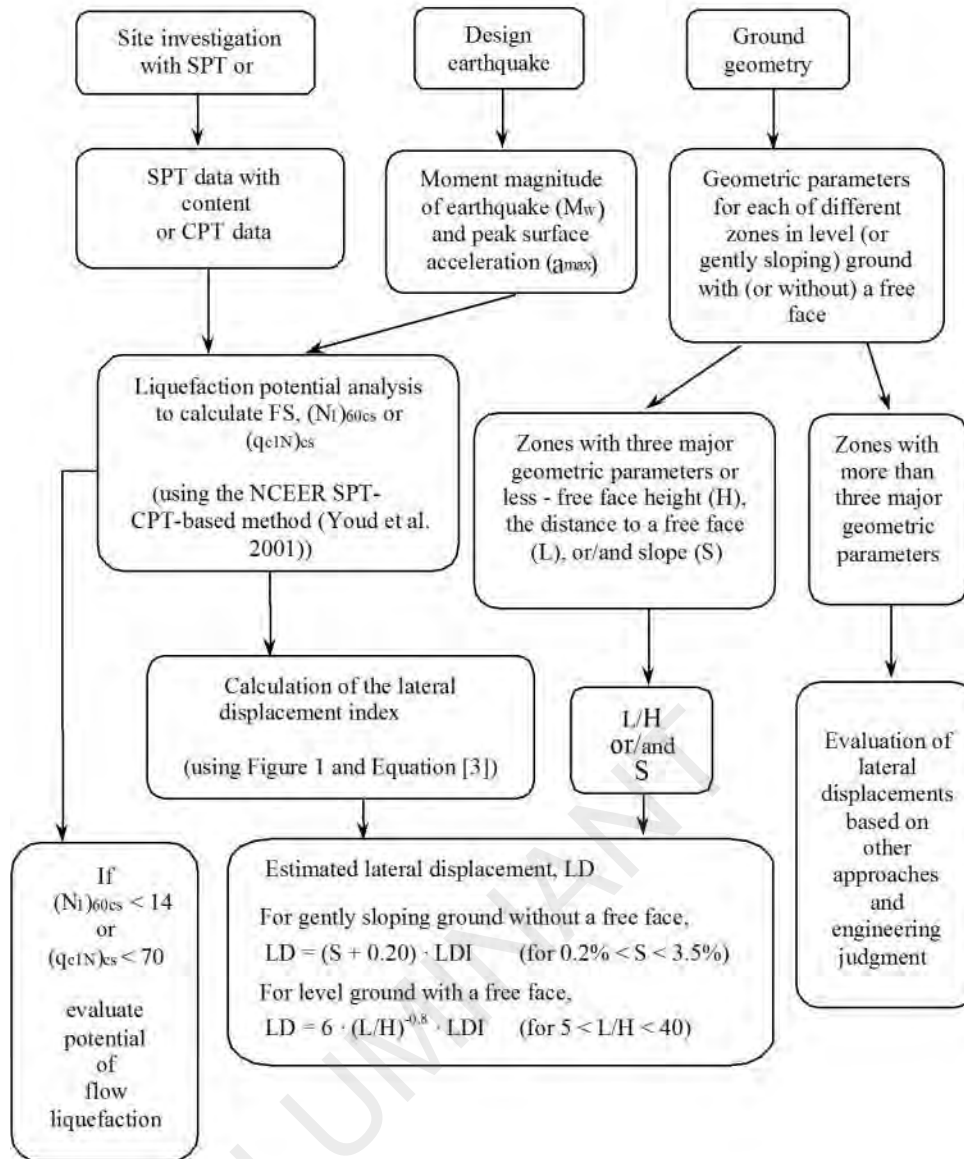

¹ Flow chart illustrating major steps in estimating liquefaction-induced lateral spreading displacements using the proposed approach

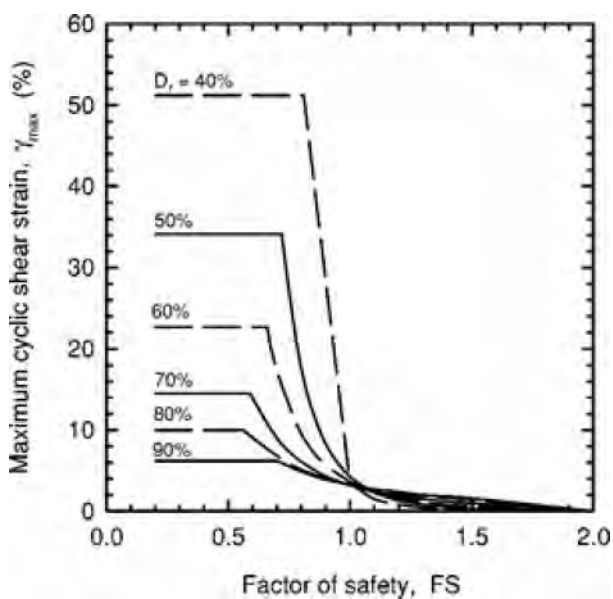

¹ Figure 1

$$LDI = \int_0^{Z_{max}} \gamma_{max} dz$$

¹ Equation [3]

¹ "Estimating liquefaction-induced ground settlements from CPT for level ground", G. Zhang, P.K. Robertson, and R.W.I. Brachman

Procedure for the estimation of seismic induced settlements in dry sands

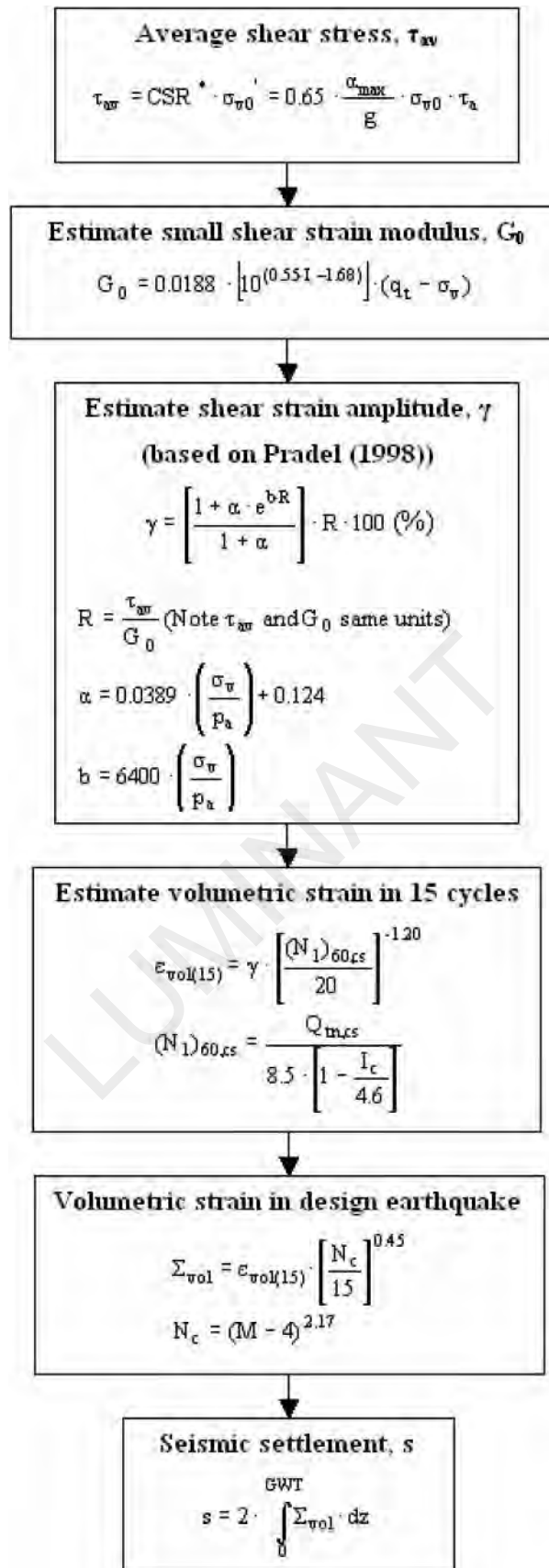

Robertson, P.K. and Lisheng, S., 2010, "Estimation of seismic compression in dry soils using the CPT" FIFTH INTERNATIONAL CONFERENCE ON RECENT ADVANCES IN GEOTECHNICAL EARTHQUAKE ENGINEERING AND SOIL DYNAMICS, Symposium in honor of professor I. M. Idriss, San Diego, CA

Liquefaction Potential Index (LPI) calculation procedure

Calculation of the Liquefaction Potential Index (LPI) is used to interpret the liquefaction assessment calculations in terms of severity over depth. The calculation procedure is based on the methodology developed by Iwasaki (1982) and is adopted by AFPS.

To estimate the severity of liquefaction extent at a given site, LPI is calculated based on the following equation:

$$LPI = \int_0^{20} (10 - 0.5z) \times F_L \times dz$$

where:

$F_L = 1 - F.S.$ when F.S. less than 1

$F_L = 0$ when F.S. greater than 1

z depth of measurement in meters

Values of LPI range between zero (0) when no test point is characterized as liquefiable and 100 when all points are characterized as susceptible to liquefaction. Iwasaki proposed four (4) discrete categories based on the numeric value of LPI:

- LPI = 0 : Liquefaction risk is very low
- $0 < LPI \leq 5$: Liquefaction risk is low
- $5 < LPI \leq 15$: Liquefaction risk is high
- LPI > 15 : Liquefaction risk is very high

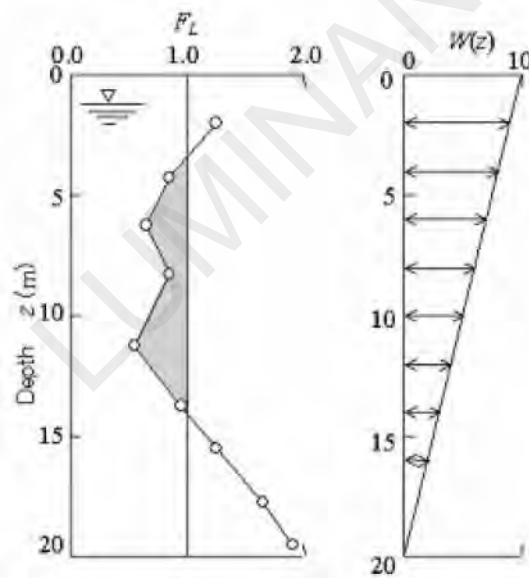

Graphical presentation of the LPI calculation procedure

References

- Lunne, T., Robertson, P.K., and Powell, J.J.M 1997. Cone penetration testing in geotechnical practice, E & FN Spon Routledge, 352 p, ISBN 0-7514-0393-8.
- Boulanger, R.W. and Idriss, I. M., 2007. Evaluation of Cyclic Softening in Silts and Clays. ASCE Journal of Geotechnical and Geoenvironmental Engineering June, Vol. 133, No. 6 pp 641-652
- Boulanger, R.W. and Idriss, I. M., 2014. CPT AND SPT BASED LIQUEFACTION TRIGGERING PROCEDURES. DEPARTMENT OF CIVIL & ENVIRONMENTAL ENGINEERING COLLEGE OF ENGINEERING UNIVERSITY OF CALIFORNIA AT DAVIS
- Robertson, P.K. and Cabal, K.L., 2007, Guide to Cone Penetration Testing for Geotechnical Engineering. Available at no cost at <http://www.geologismiki.gr/>
- Robertson, P.K. 1990. Soil classification using the cone penetration test. Canadian Geotechnical Journal, 27 (1), 151-8.
- Robertson, P.K. and Wride, C.E., 1998. Cyclic Liquefaction and its Evaluation based on the CPT Canadian Geotechnical Journal, 1998, Vol. 35, August.
- Youd, T.L., Idriss, I.M., Andrus, R.D., Arango, I., Castro, G., Christian, J.T., Dobry, R., Finn, W.D.L., Harder, L.F., Hynes, M.E., Ishihara, K., Koester, J., Liao, S., Marcuson III, W.F., Martin, G.R., Mitchell, J.K., Moriwaki, Y., Power, M.S., Robertson, P.K., Seed, R., and Stokoe, K.H., Liquefaction Resistance of Soils: Summary Report from the 1996 NCEER and 1998 NCEER/NSF Workshop on Evaluation of Liquefaction Resistance of Soils, ASCE, Journal of Geotechnical & Geoenvironmental Engineering, Vol. 127, October, pp 817-833
- Zhang, G., Robertson. P.K., Brachman, R., 2002, Estimating Liquefaction Induced Ground Settlements from the CPT, Canadian Geotechnical Journal, 39: pp 1168-1180
- Zhang, G., Robertson. P.K., Brachman, R., 2004, Estimating Liquefaction Induced Lateral Displacements using the SPT and CPT, ASCE, Journal of Geotechnical & Geoenvironmental Engineering, Vol. 130, No. 8, 861-871
- Pradel, D., 1998, Procedure to Evaluate Earthquake-Induced Settlements in Dry Sandy Soils, ASCE, Journal of Geotechnical & Geoenvironmental Engineering, Vol. 124, No. 4, 364-368
- Iwasaki, T., 1986, Soil liquefaction studies in Japan: state-of-the-art, Soil Dynamics and Earthquake Engineering, Vol. 5, No. 1, 2-70
- Papathanassiou G., 2008, LPI-based approach for calibrating the severity of liquefaction-induced failures and for assessing the probability of liquefaction surface evidence, Eng. Geol. 96:94–104
- P.K. Robertson, 2009, Interpretation of Cone Penetration Tests - a unified approach., Canadian Geotechnical Journal, Vol. 46, No. 11, pp 1337-1355
- P.K. Robertson, 2009. "Performance based earthquake design using the CPT", Keynote Lecture, International Conference on Performance-based Design in Earthquake Geotechnical Engineering - from case history to practice, IS-Tokyo, June 2009
- Robertson, P.K. and Lisheng, S., 2010, "Estimation of seismic compression in dry soils using the CPT" FIFTH INTERNATIONAL CONFERENCE ON RECENT ADVANCES IN GEOTECHNICAL EARTHQUAKE ENGINEERING AND SOIL DYNAMICS, *Symposium in honor of professor I. M. Idriss*, SAN diego, CA
- R. E. S. Moss, R. B. Seed, R. E. Kayen, J. P. Stewart, A. Der Kiureghian, K. O. Cetin, CPT-Based Probabilistic and Deterministic Assessment of In Situ Seismic Soil Liquefaction Potential, Journal of Geotechnical and Geoenvironmental Engineering, Vol. 132, No. 8, August 1, 2006
- I. M. Idriss and R. W. Boulanger, 2008. Soil liquefaction during earthquakes, Earthquake Engineering Research Institute MNO-12

APPENDIX D
SLOPE STABILITY ANALYSIS RESULTS

LUMINANT

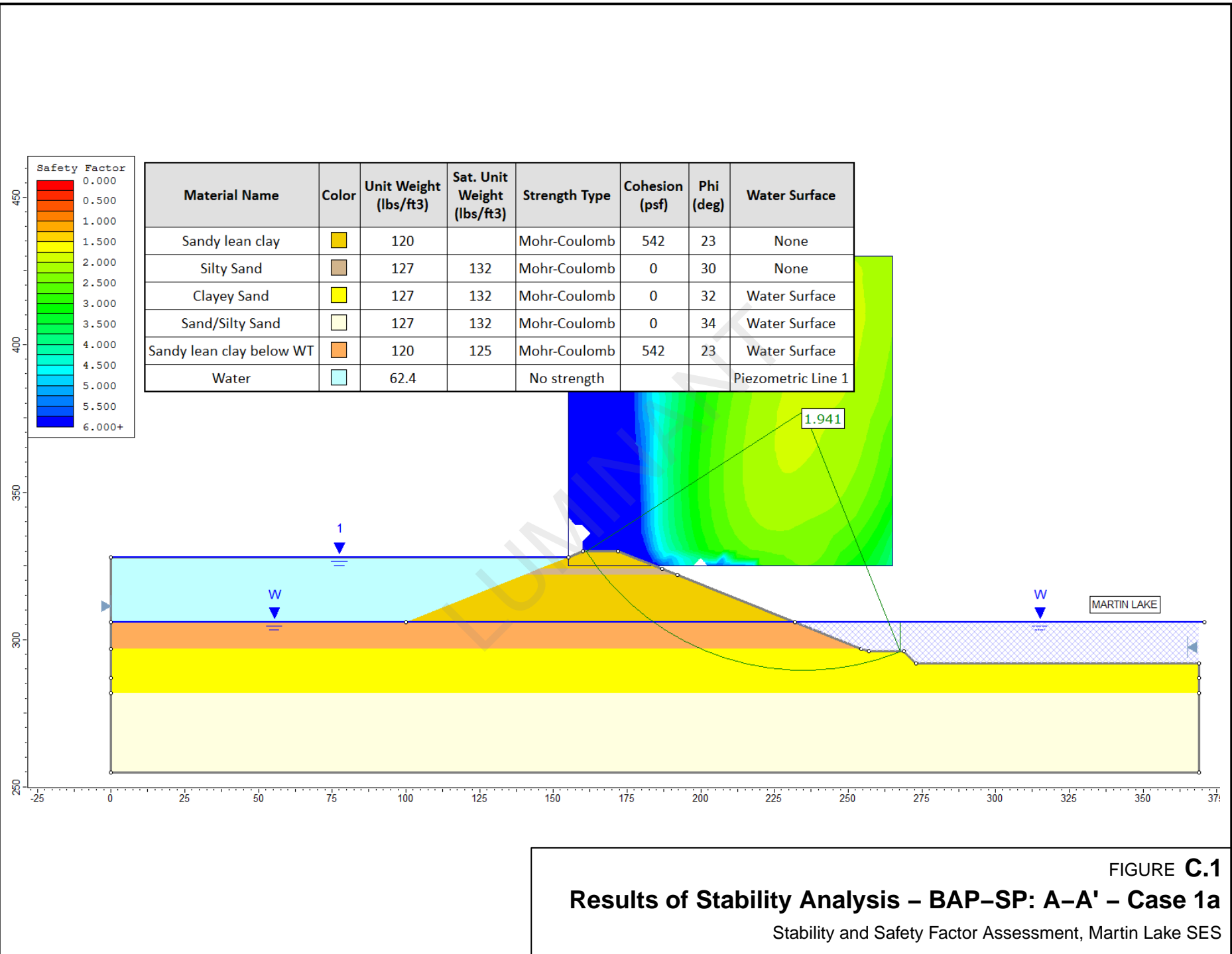

FIGURE C.1
Results of Stability Analysis – BAP-SP: A-A' – Case 1a
 Stability and Safety Factor Assessment, Martin Lake SES

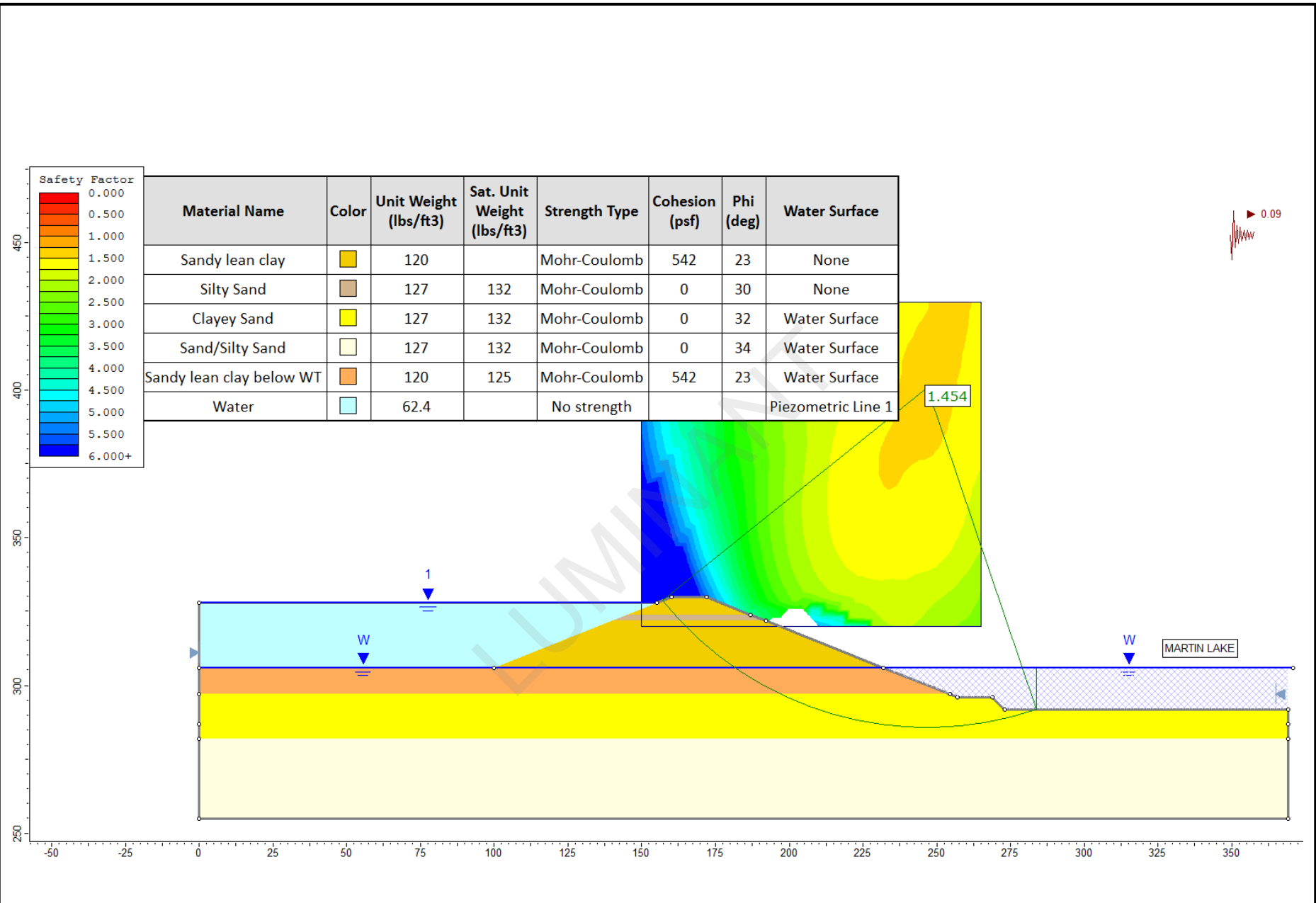

FIGURE C.2
Results of Stability Analysis – BAP-SP: A-A' – Case 1b
 Stability and Safety Factor Assessment, Martin Lake SES

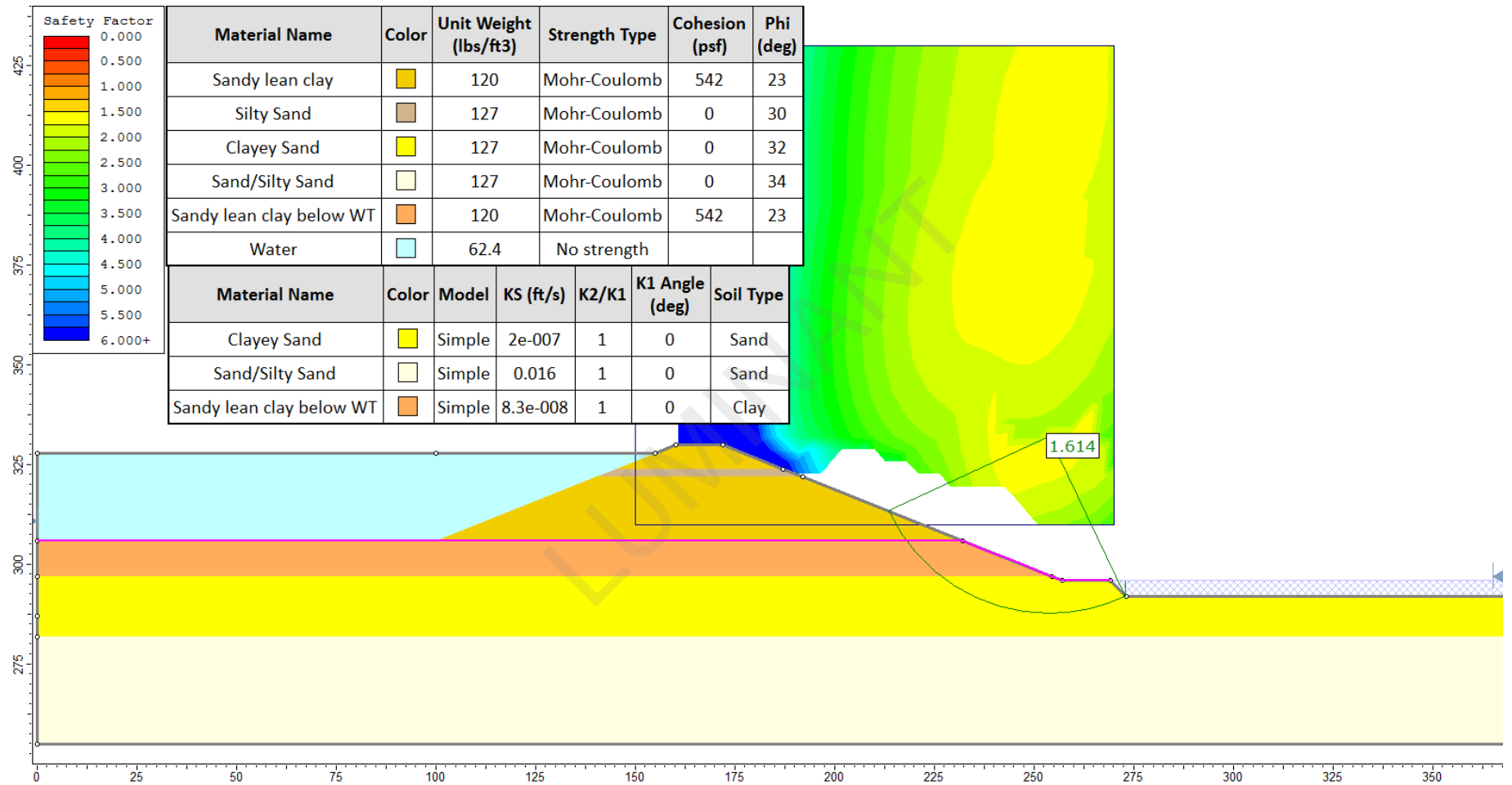

FIGURE C.3
Results of Stability Analysis – BAP-SP: A-A' – Case 1c
 Stability and Safety Factor Assessment, Martin Lake SES

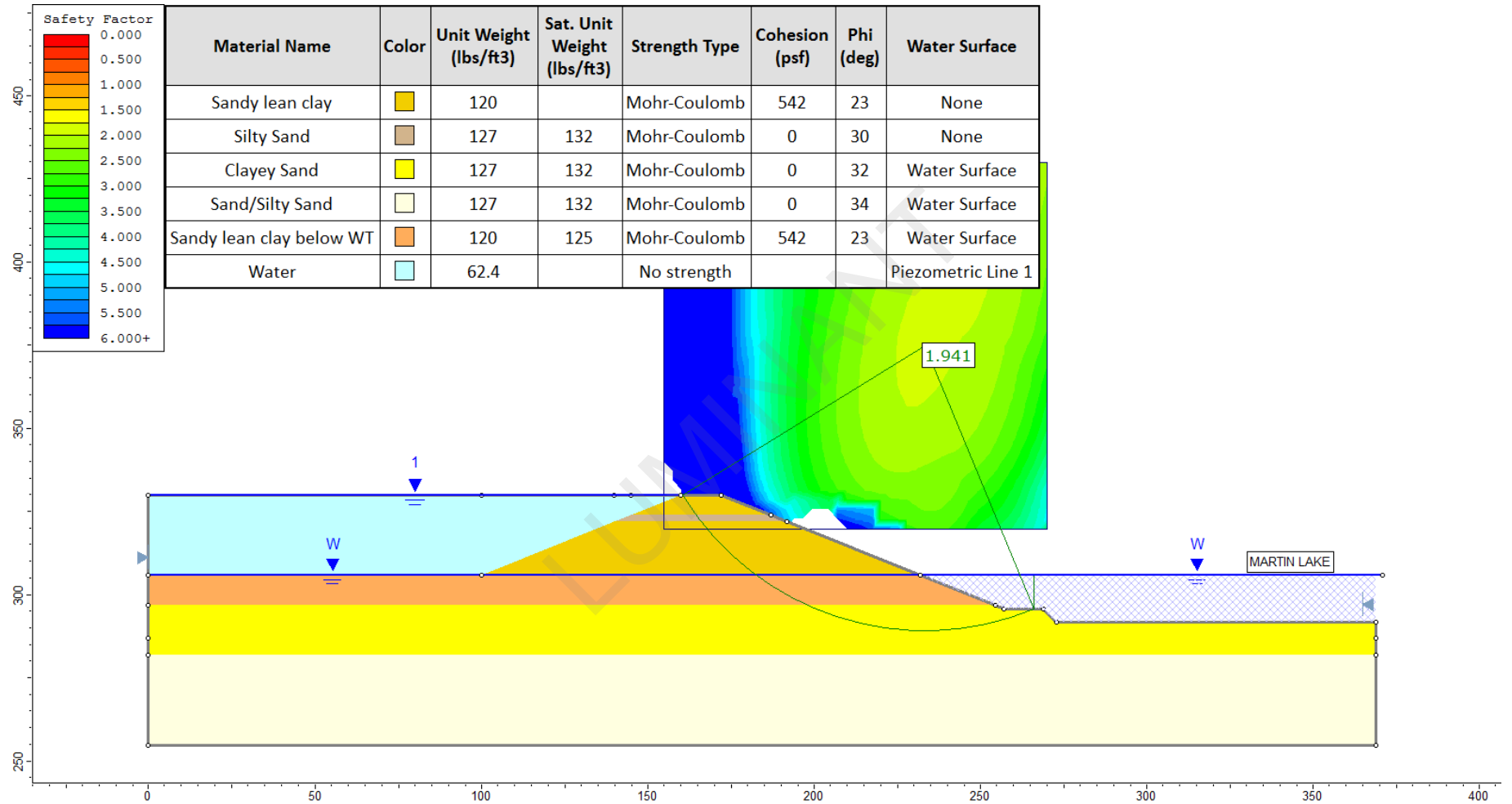

FIGURE C.4
Results of Stability Analysis – BAP-SP: A-A' – Case 2a
 Stability and Safety Factor Assessment, Martin Lake SES

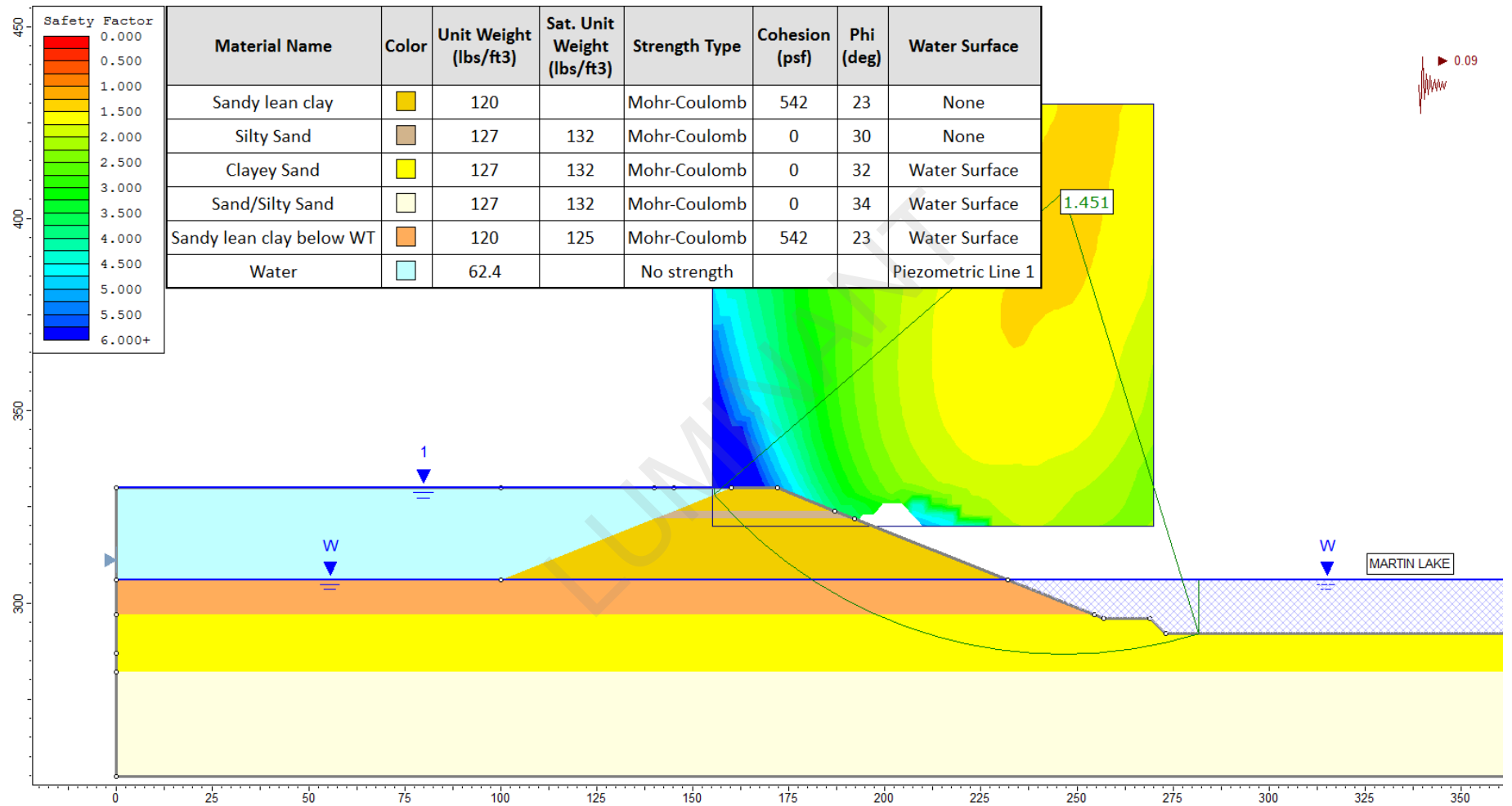

FIGURE C.5
Results of Stability Analysis – BAP–SP: A–A' – Case 2b
 Stability and Safety Factor Assessment, Martin Lake SES

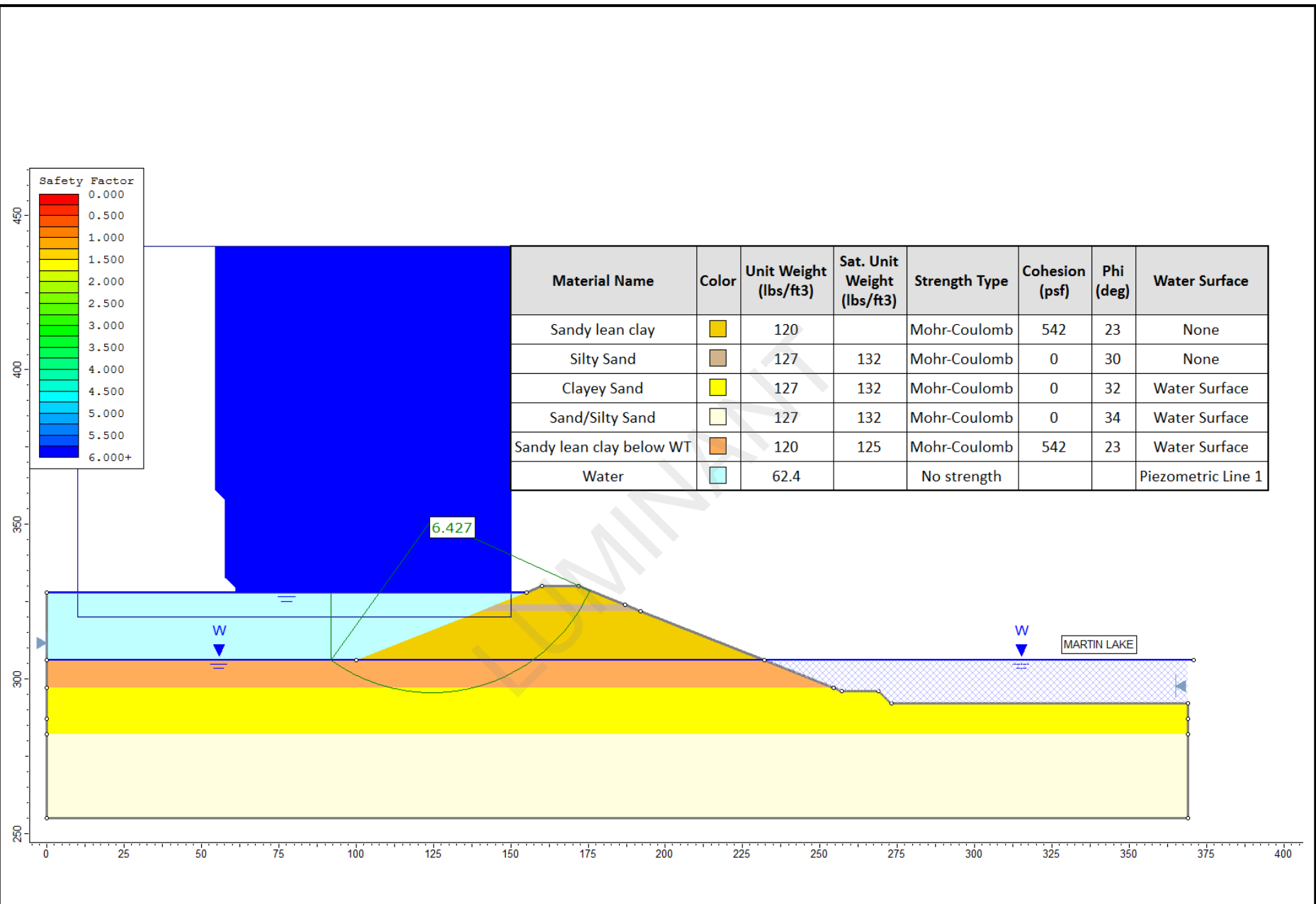

FIGURE C.6
Results of Stability Analysis – BAP-SP: A-A' – Case 3a
 Stability and Safety Factor Assessment, Martin Lake SES

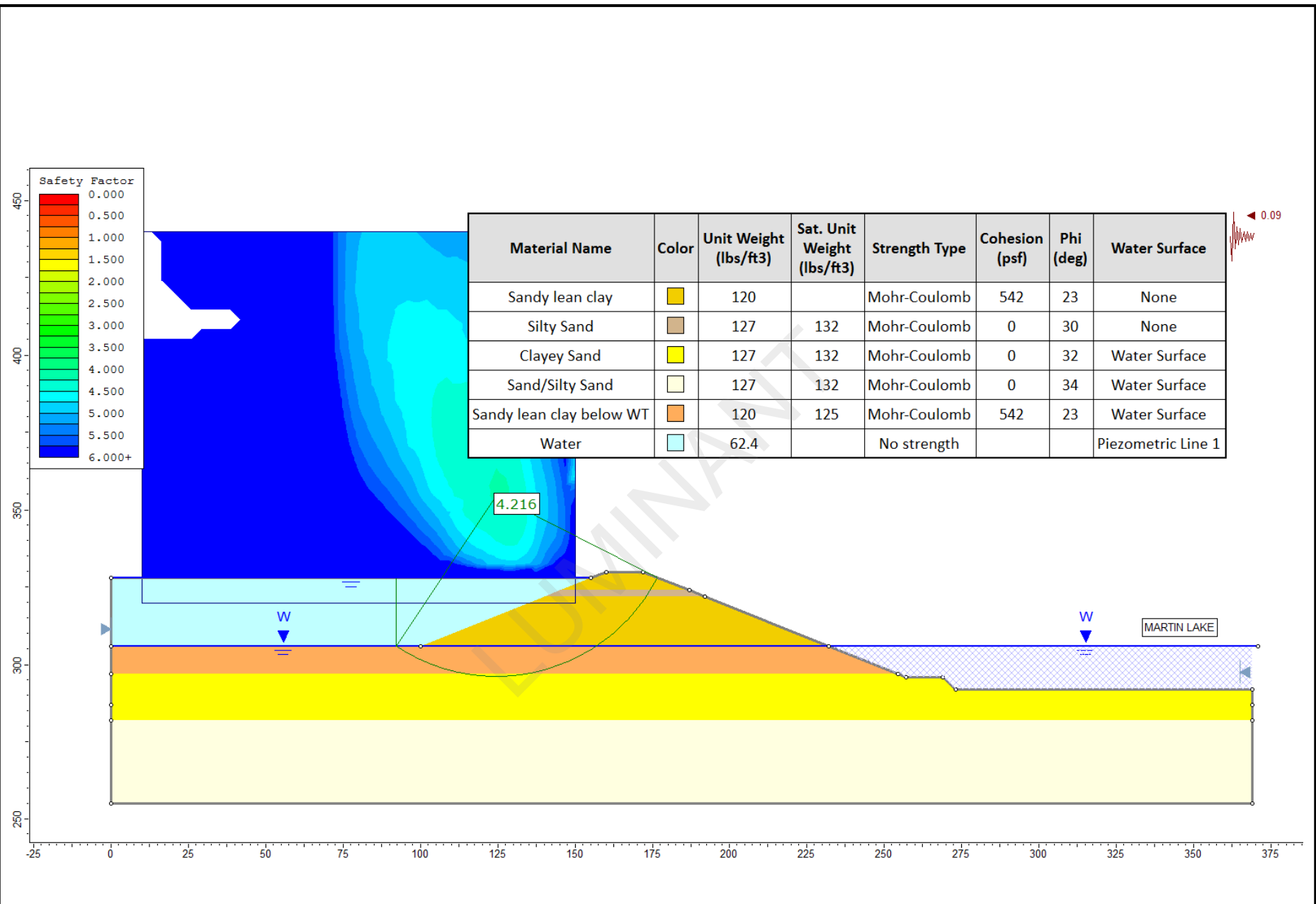
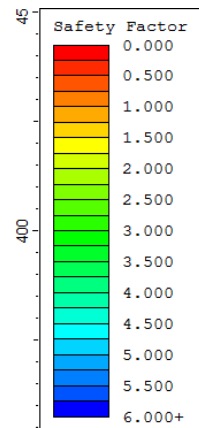

FIGURE C.7
Results of Stability Analysis – BAP–SP: A–A' – Case 3b
 Stability and Safety Factor Assessment, Martin Lake SES



Material Name	Color	Unit Weight (lbs/ft ³)	Sat. Unit Weight (lbs/ft ³)	Strength Type	Cohesion (psf)	Phi (deg)	Water Surface
Sandy lean clay		120		Mohr-Coulomb	542	23	None
Silty Sand		127	132	Mohr-Coulomb	0	30	None
Clayey Sand		127	132	Mohr-Coulomb	0	32	Water Surface
Sand/Silty Sand		127	132	Mohr-Coulomb	0	34	Water Surface
Sandy lean clay below WT		120	125	Mohr-Coulomb	542	23	Water Surface
Water		62.4		No strength			Piezometric Line 1

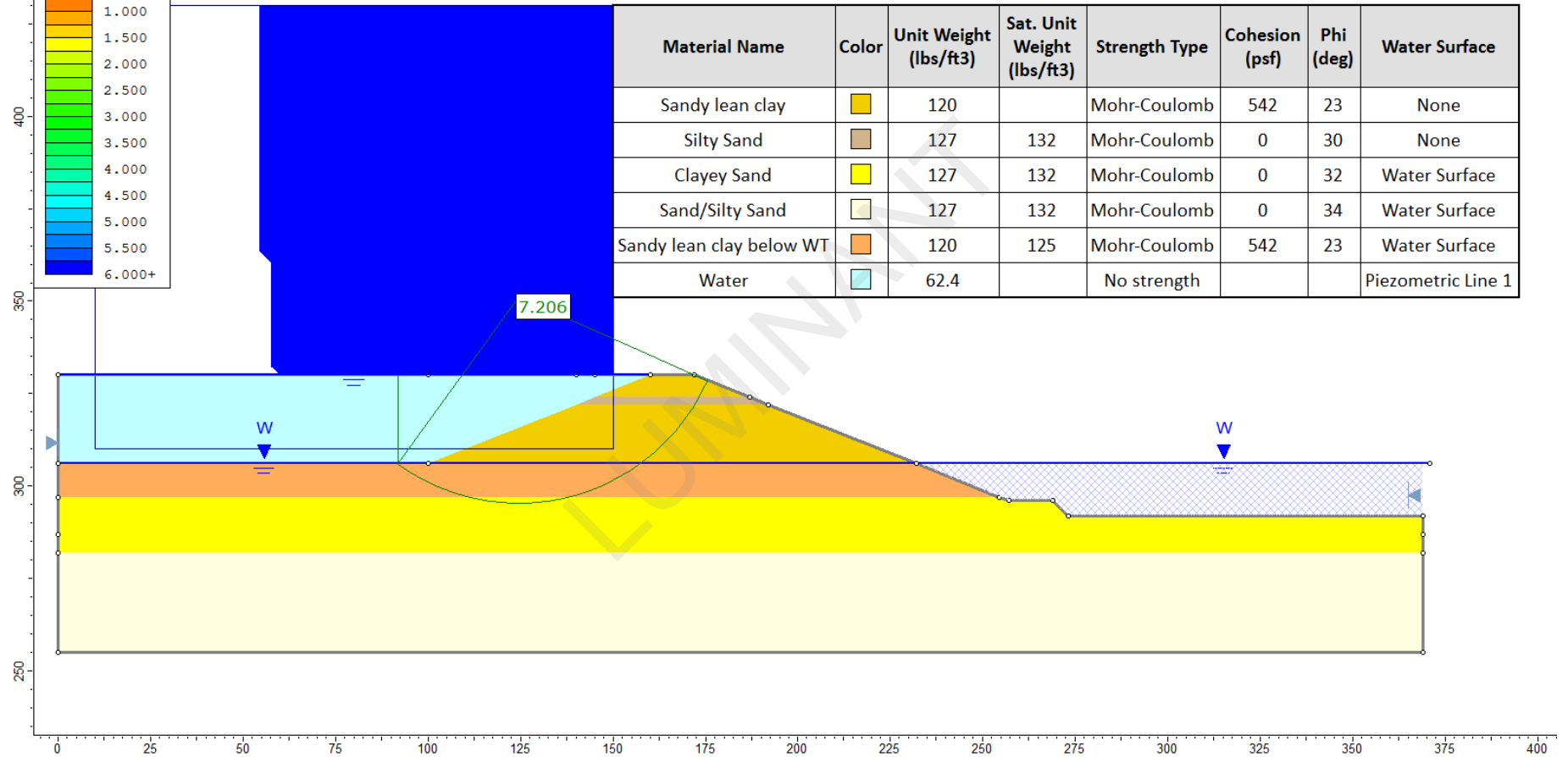

FIGURE C.8
Results of Stability Analysis – BAP-SP: A-A' – Case 4a
 Stability and Safety Factor Assessment, Martin Lake SES

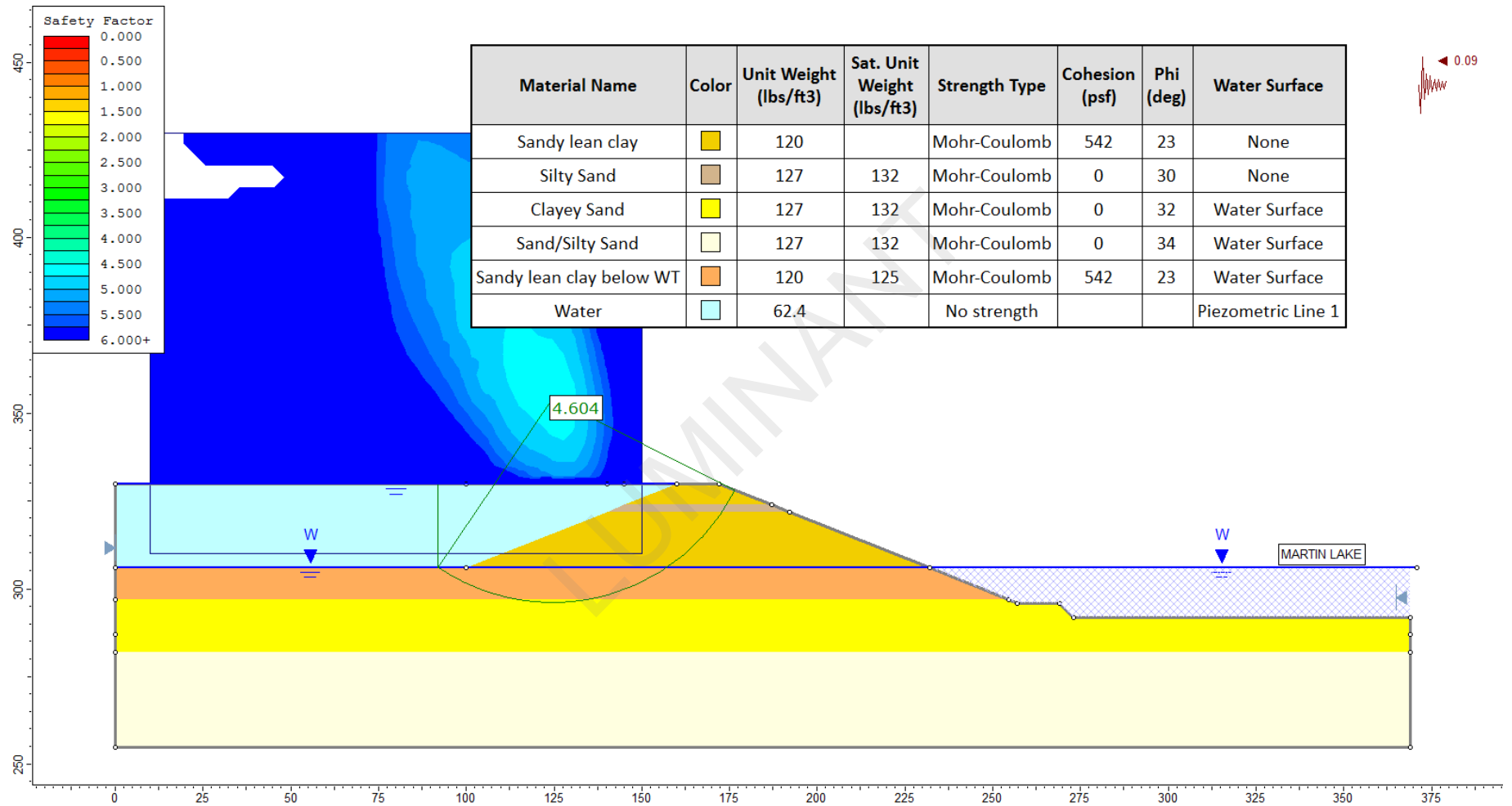

FIGURE C.9
Results of Stability Analysis – BAP–SP: A–A' – Case 4b
 Stability and Safety Factor Assessment, Martin Lake SES

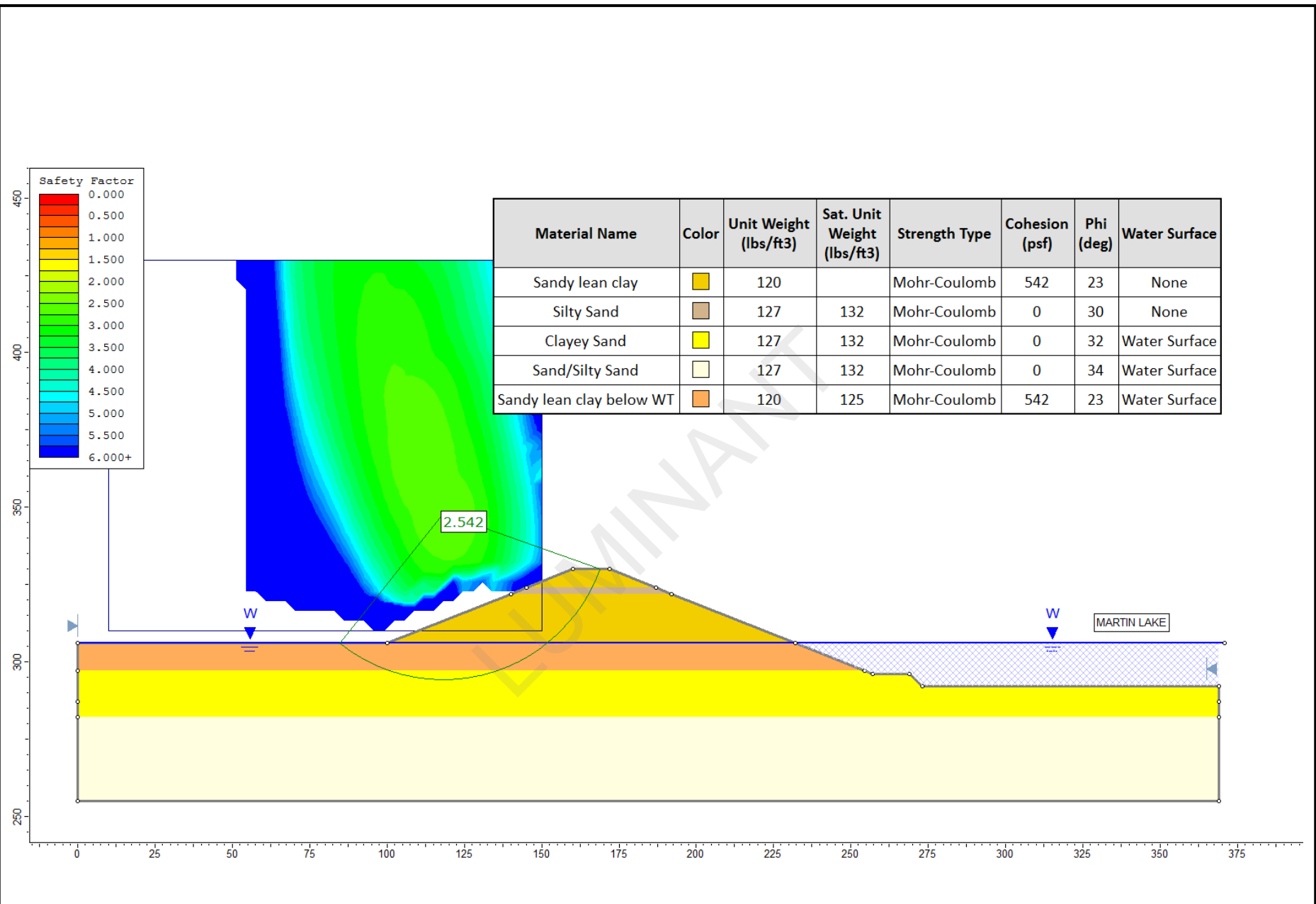

FIGURE C.10
Results of Stability Analysis – BAP–SP: A–A' – Case 5a
 Stability and Safety Factor Assessment, Martin Lake SES

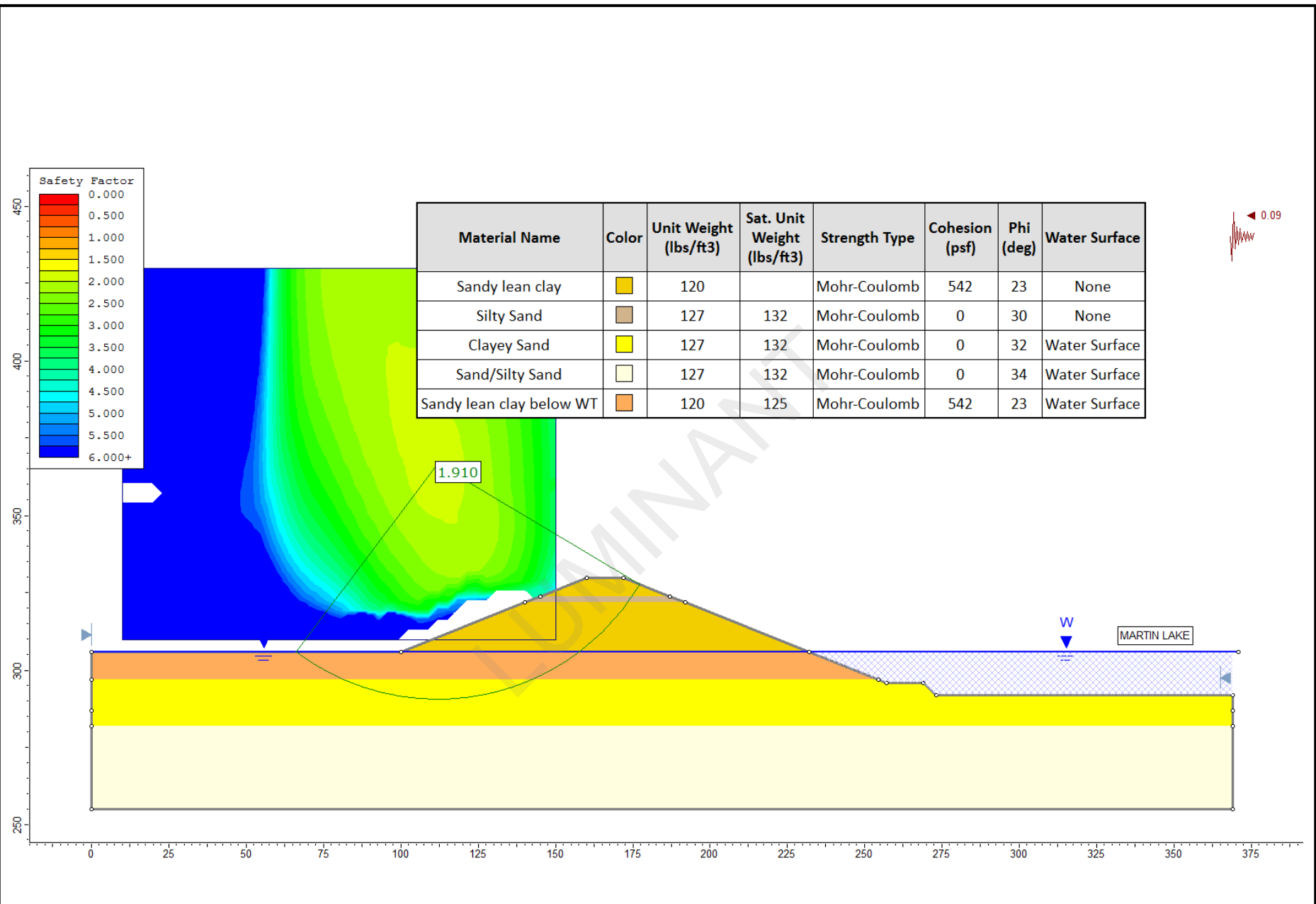
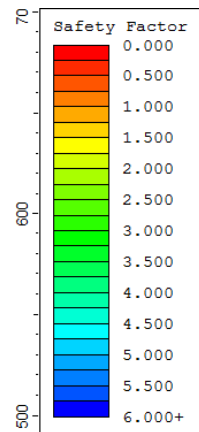

FIGURE C.11
Results of Stability Analysis – BAP–SP: A–A' – Case 5b
 Stability and Safety Factor Assessment, Martin Lake SES



Material Name	Color	Unit Weight (lbs/ft ³)	Strength Type	Cohesion (psf)	Phi (deg)
PDP-5 embankment - sandy site soils		125	Mohr-Coulomb	0	34.7
Compacted clay liner		127	Mohr-Coulomb	650	31.4
Old ash		90	Mohr-Coulomb	0	34.6
Deep sand		127	Mohr-Coulomb	0	34
Old PDP embankment - Sandy clay/Clayey sand		127	Mohr-Coulomb	650	31.4

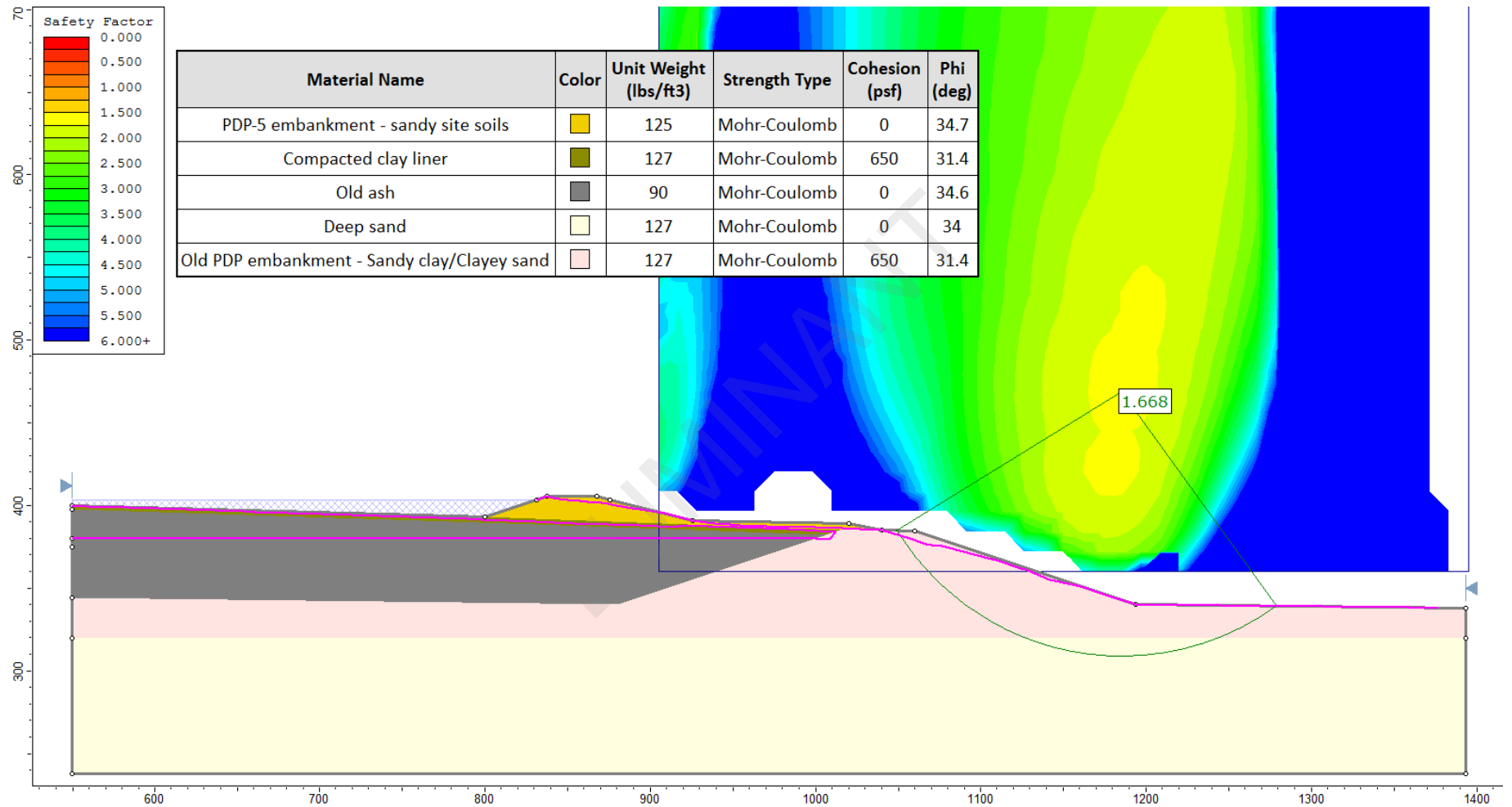

FIGURE C.12
Results of Stability Analysis – PDP5: B–B' – Case 1a

Stability and Safety Factor Assessment, Martin Lake SES

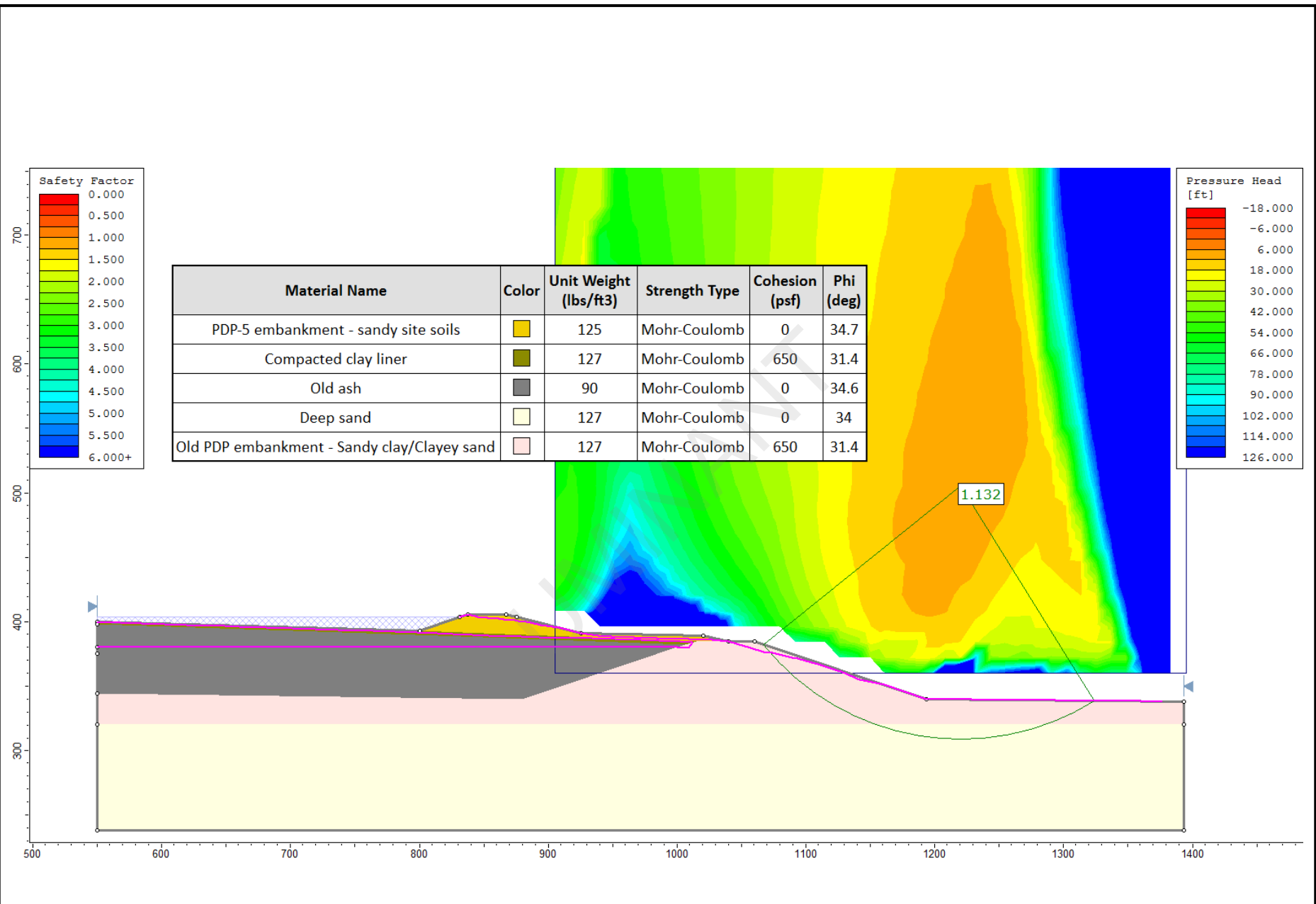

FIGURE C.13
Results of Stability Analysis – PDP5: B–B' – Case 1b

Stability and Safety Factor Assessment, Martin Lake SES

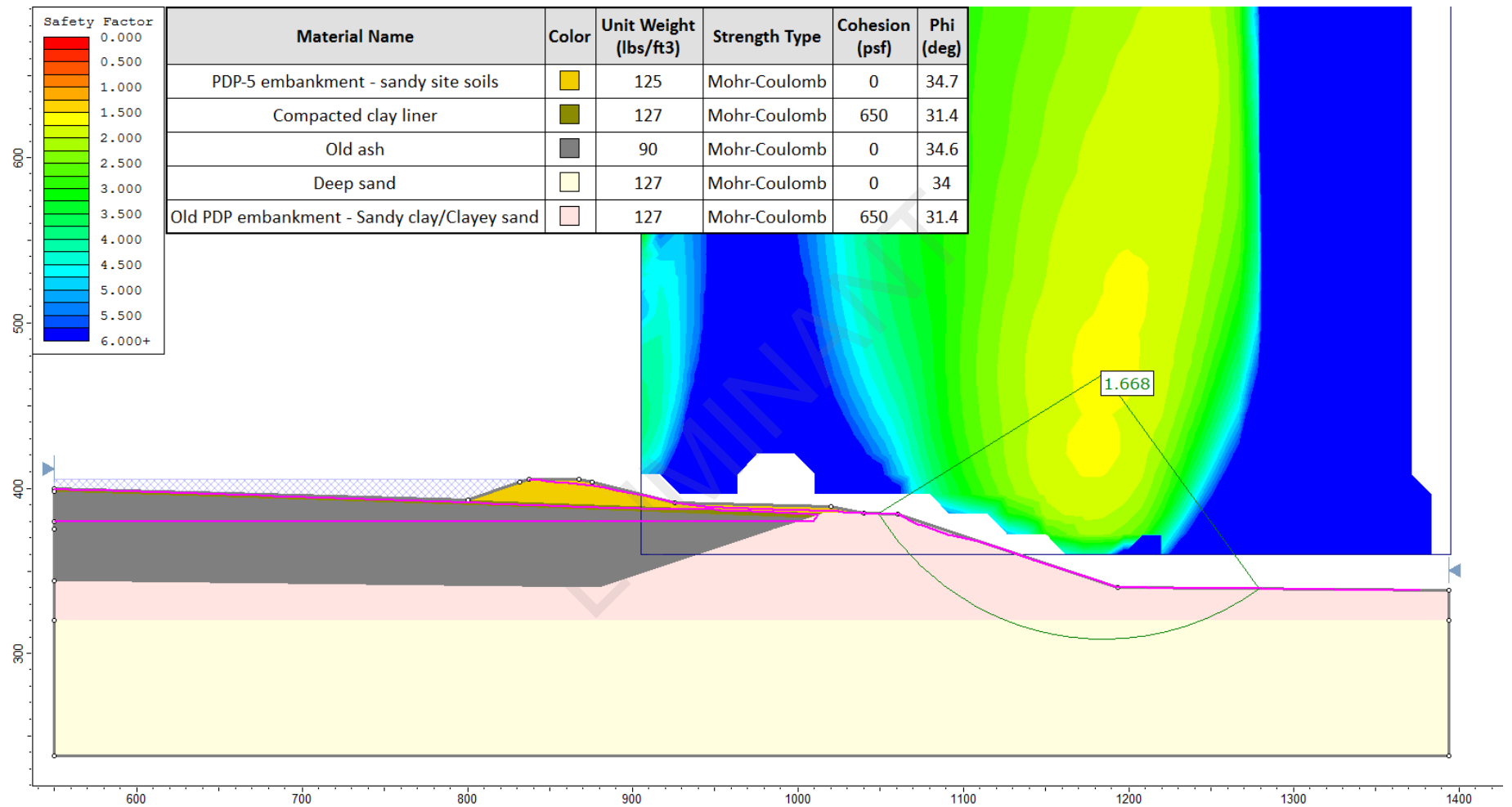

FIGURE C.14
Results of Stability Analysis – PDP5: B–B' – Case 2a

Stability and Safety Factor Assessment, Martin Lake SES

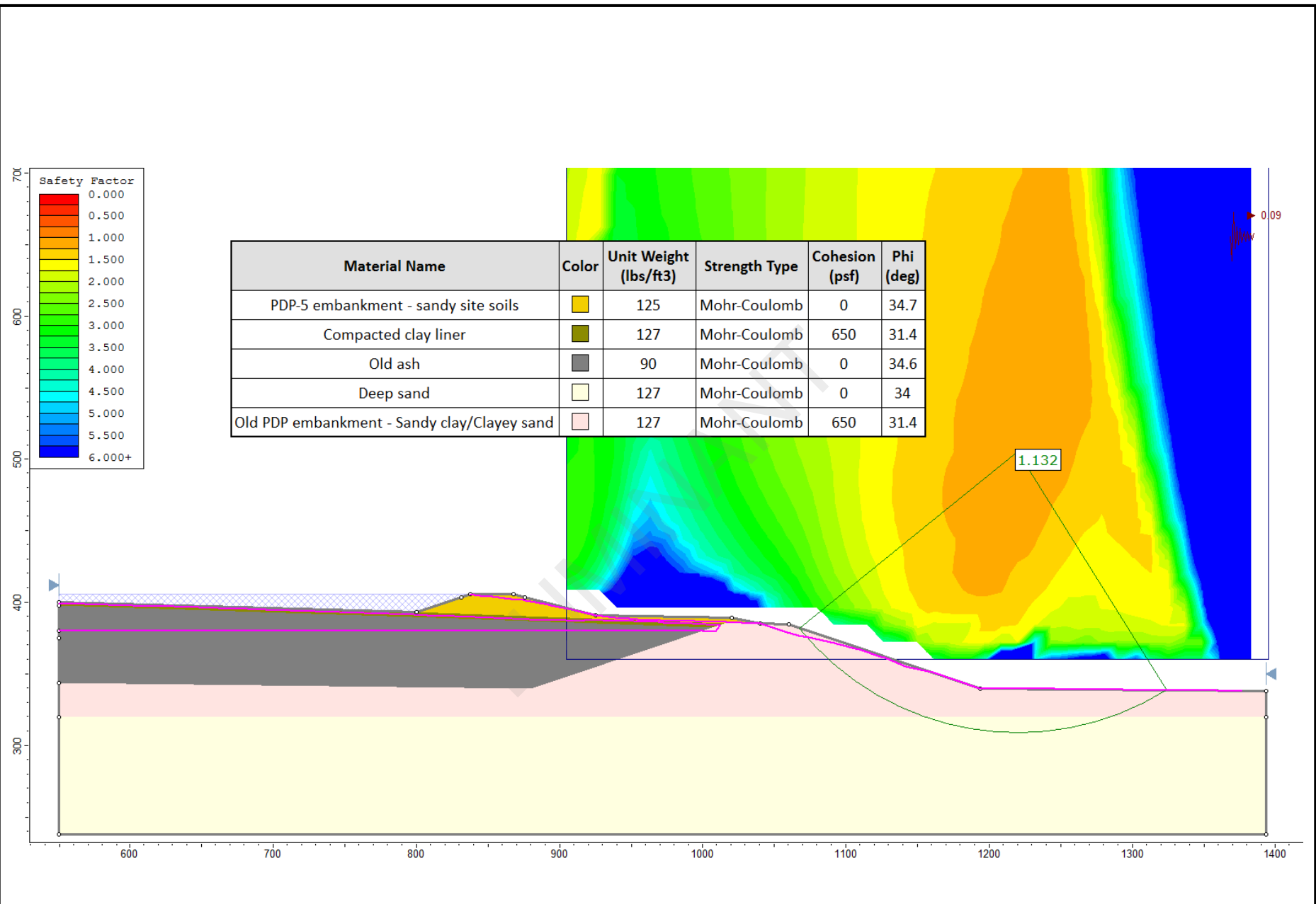

FIGURE C.15
Results of Stability Analysis – PDP5: B–B' – Case 2b

Stability and Safety Factor Assessment, Martin Lake SES

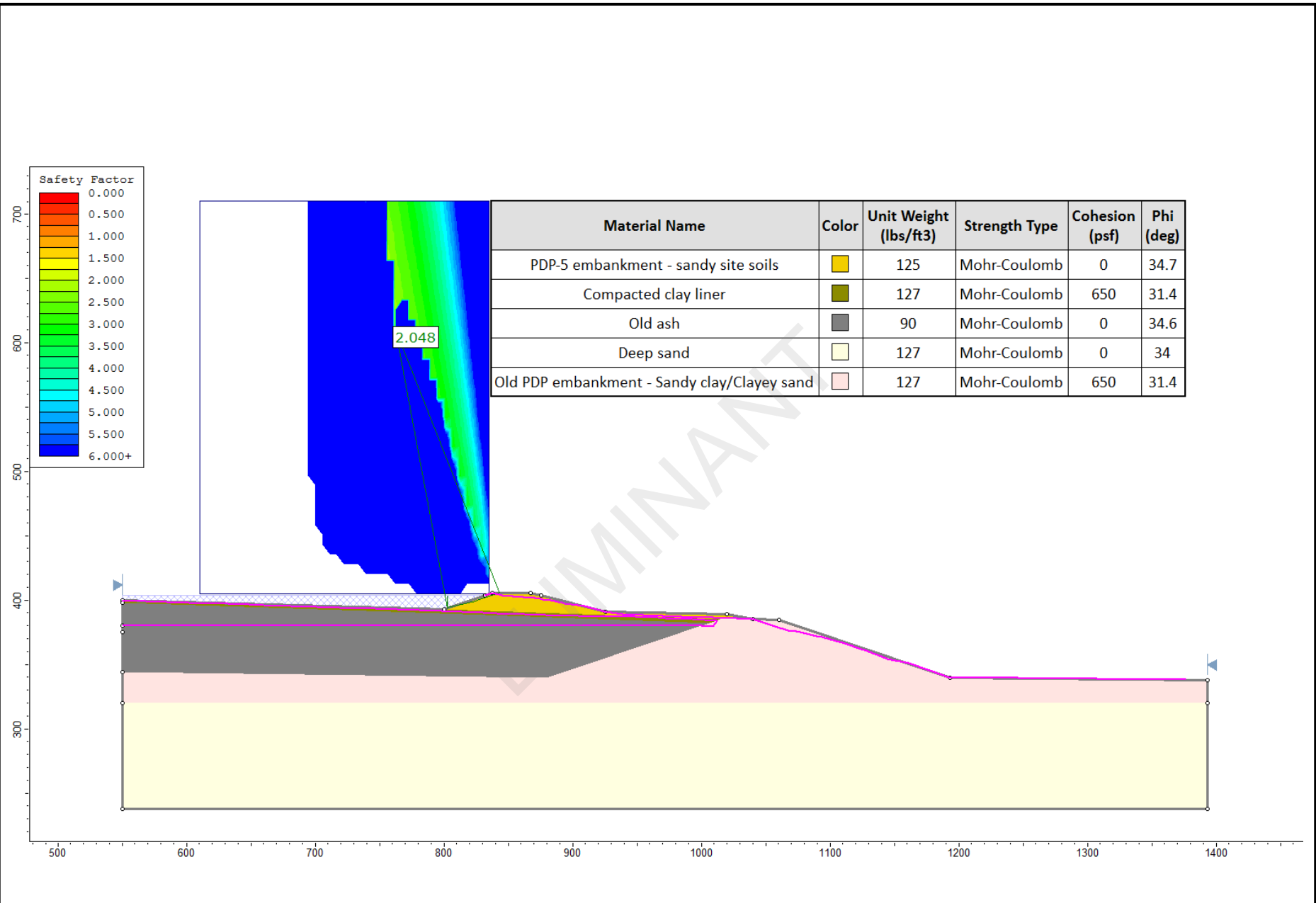

FIGURE C.16
Results of Stability Analysis – PDP5: B–B' – Case 3a

Stability and Safety Factor Assessment, Martin Lake SES

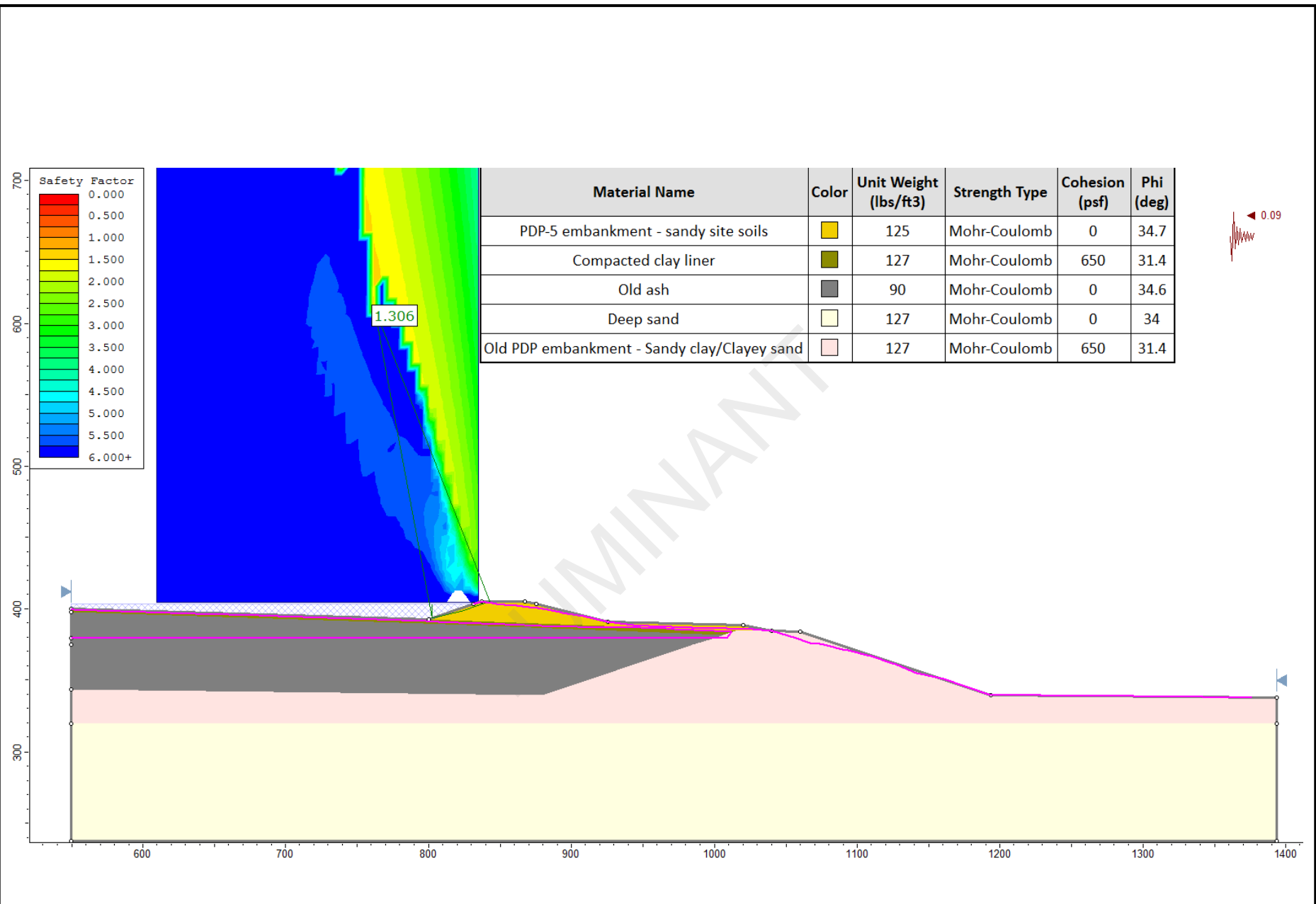

FIGURE C.17
Results of Stability Analysis – PDP5: B–B' – Case 3b

Stability and Safety Factor Assessment, Martin Lake SES

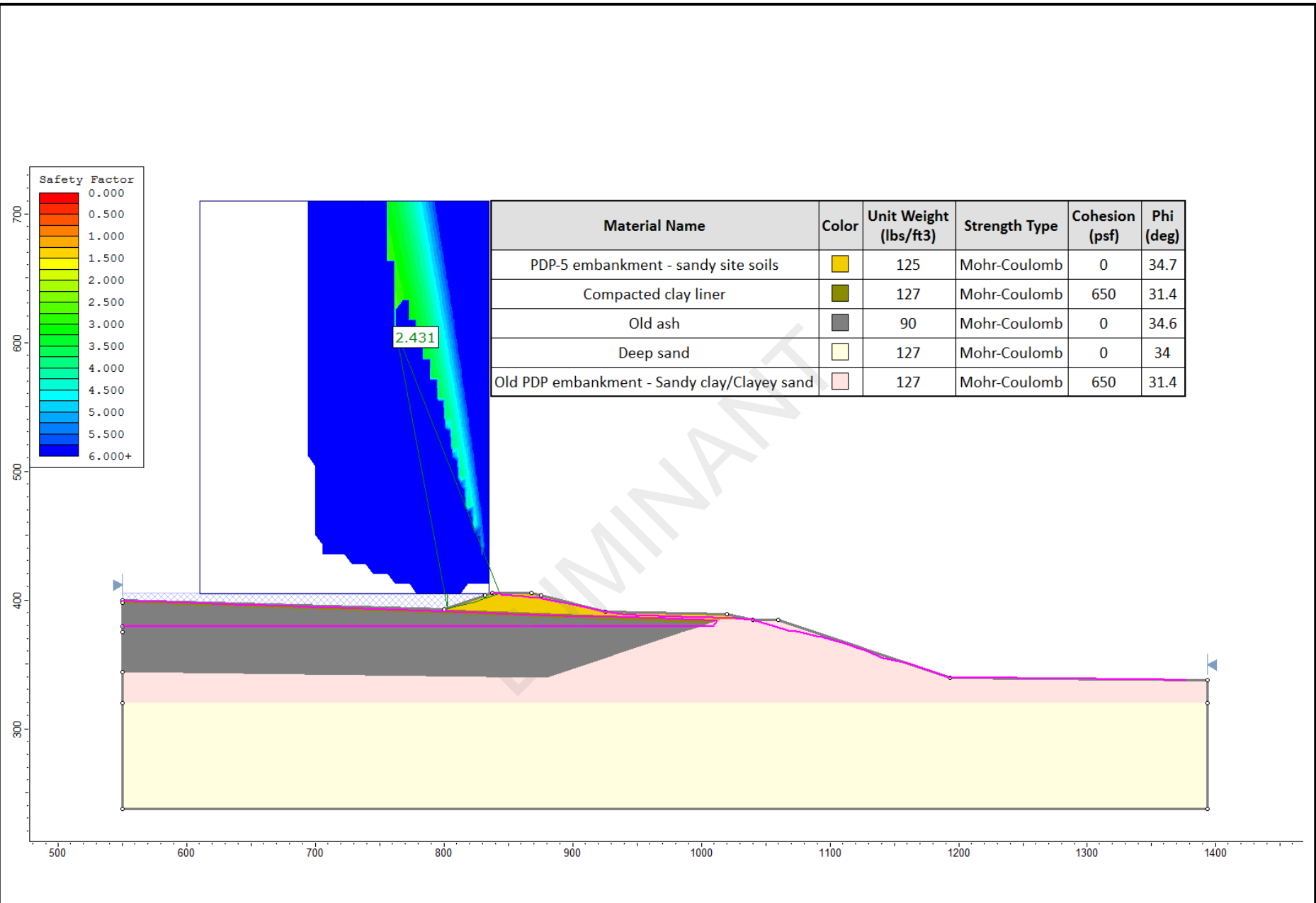
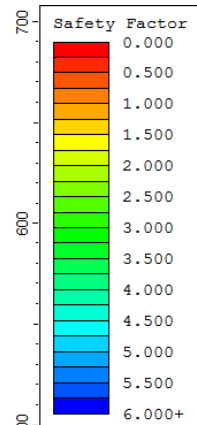

FIGURE C.18
Results of Stability Analysis – PDP5: B–B' – Case 4a
 Stability and Safety Factor Assessment, Martin Lake SES



Material Name	Color	Unit Weight (lbs/ft ³)	Strength Type	Cohesion (psf)	Phi (deg)
PDP-5 embankment - sandy site soils		125	Mohr-Coulomb	0	34.7
Compacted clay liner		127	Mohr-Coulomb	650	31.4
Old ash		90	Mohr-Coulomb	0	34.6
Deep sand		127	Mohr-Coulomb	0	34
Old PDP embankment - Sandy clay/Clayey sand		127	Mohr-Coulomb	650	31.4

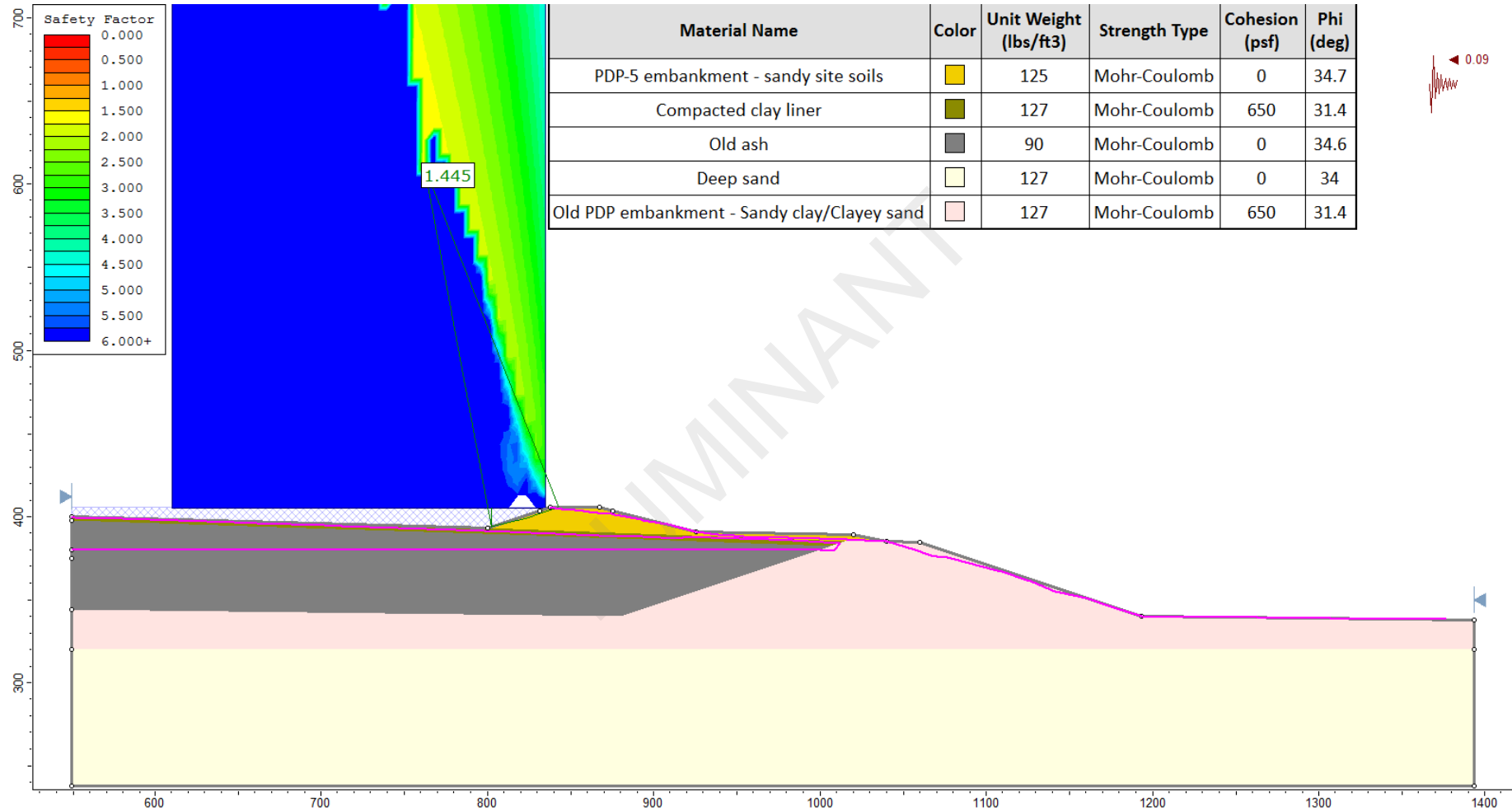

FIGURE C.19
Results of Stability Analysis – PDP5: B–B' – Case 4b
 Stability and Safety Factor Assessment, Martin Lake SES

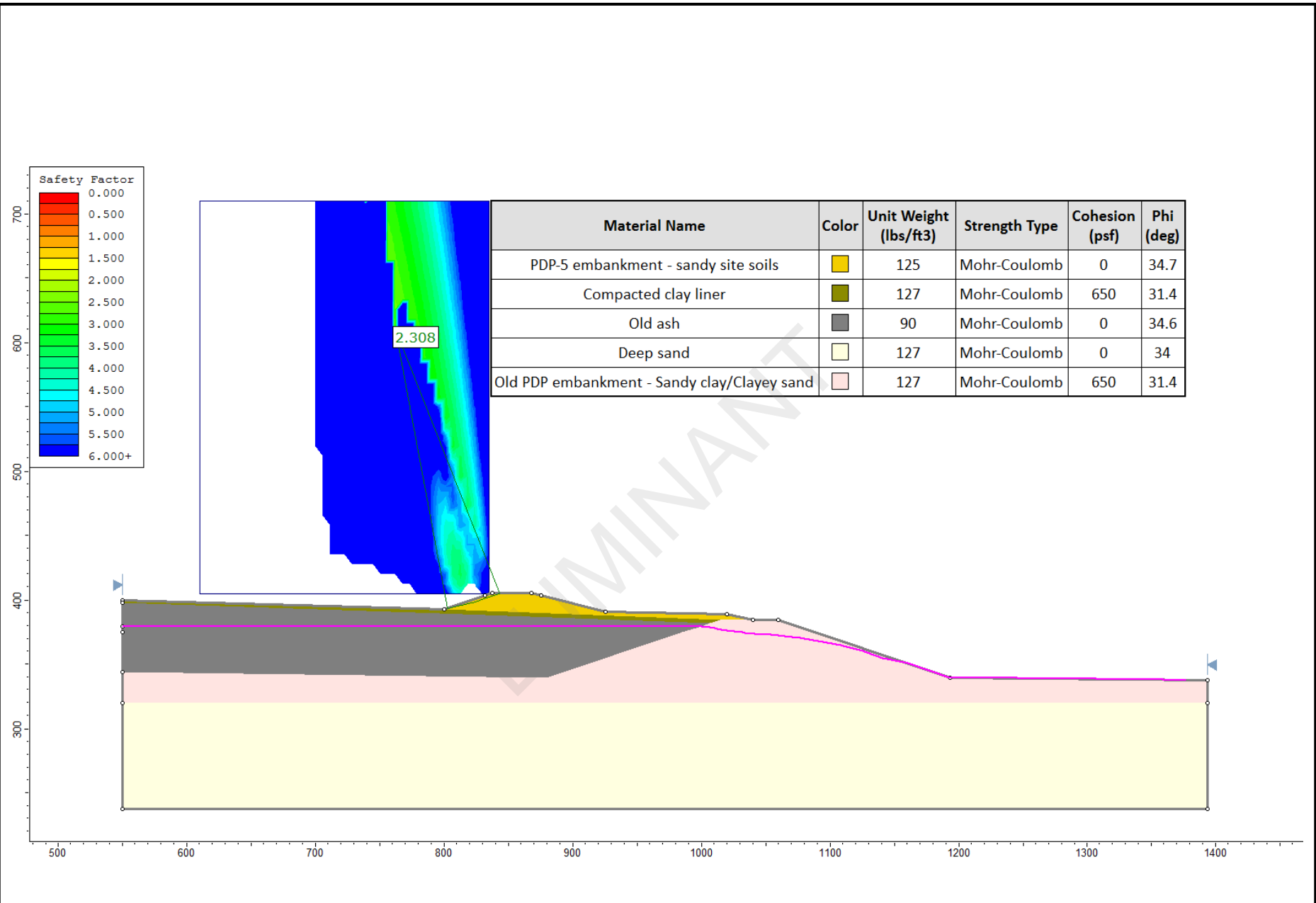

FIGURE C.20
Results of Stability Analysis – PDP5: B–B' – Case 5a
 Stability and Safety Factor Assessment, Martin Lake SES

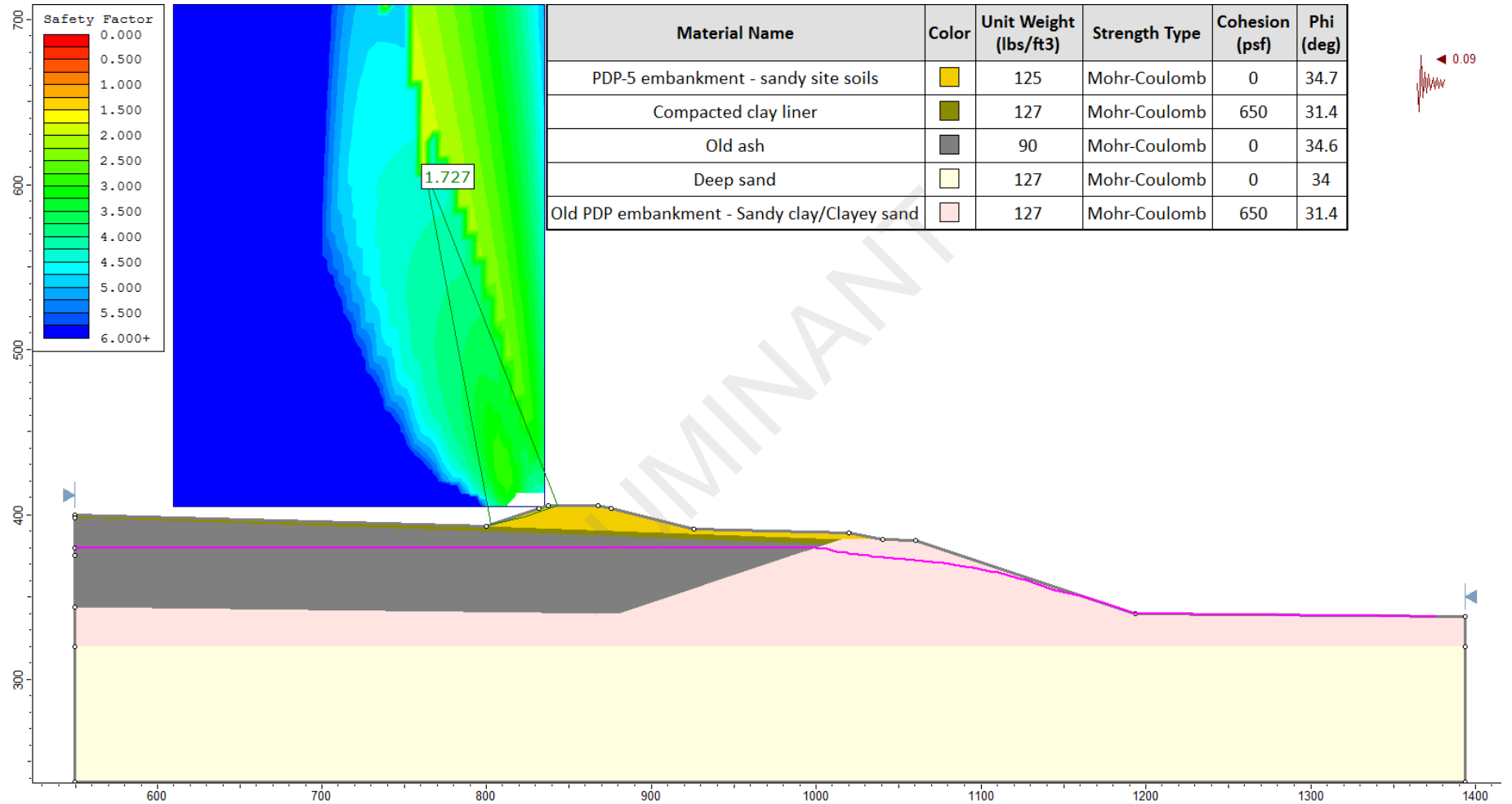

FIGURE C.21
Results of Stability Analysis – PDP5: B–B' – Case 5b
 Stability and Safety Factor Assessment, Martin Lake SES

Established in 1960, Golder Associates is a global, employee-owned organization that helps clients find sustainable solutions to the challenges of finite resources, energy and water supply and management, waste management, urbanization, and climate change. We provide a wide range of independent consulting, design, and construction services in our specialist areas of earth, environment, and energy. By building strong relationships and meeting the needs of clients, our people have created one of the most trusted professional services organizations in the world.

Africa	+ 27 11 254 4800
Asia	+ 852 2562 3658
Australasia	+ 61 3 8862 3500
Europe	+ 356 21 42 30 20
North America	+ 1 800 275 3281
South America	+ 56 2 2616 2000

solutions@golder.com
www.golder.com

Golder Associates Inc.
500 Century Plaza Drive, Suite 190
Houston, TX 77073 USA
Tel: (281) 821-6868
Fax: (281) 821-6870



Engineering Earth's Development, Preserving Earth's Integrity

Golder, Golder Associates and the GA globe design are trademarks of Golder Associates Corporation



CREATE AMAZING.

Burns & McDonnell World Headquarters
9400 Ward Parkway
Kansas City, MO 64114
O 816-333-9400
F 816-333-3690
www.burnsmcd.com